

Technical Data

Outdoor unit - Pair application



Daikin's unique position as a manufacturer of air conditioning equipment, compressors and refrigerants has led to its close involvement in environmental issues. For several years Daikin has had the intention to become a leader in the provision of products that have limited impact on the environment. This challenge demands the eco design and development of a wide range of products and an energy management system, resulting in energy conservation and a reduction of waste.



The present leaflet is drawn up by way of information only and does not constitute an offer binding upon Daikin Europe N.V. Daikin Europe N.V. has compiled the content of this leaflet to the best of its knowledge. No express or implied warranty is given for the completeness, accuracy, reliability or fitness for particular purpose of its content and the products and services presented therein. Specifications are subject to change without prior notice. Daikin Europe N.V. explicitly rejects any liability for any direct or indirect damage, in the broadest sense, arising from or related to the use and/or interpretation of this leaflet. All content is copyrighted by Daikin Europe N.V.

Daikin products are distributed by:



Daikin Europe N.V. participates in the Eurovent Certification Programme for Air Conditioners (AC), Liquid Cooling Packages (LCP) and Fan Coil Units (FCU). The certified data of certified models are listed in the Eurovent Directory. Multi units are Eurovent certified for combinations up to 2 indoor units.



Air Conditioners Technical Data

Outdoor unit - Pair application

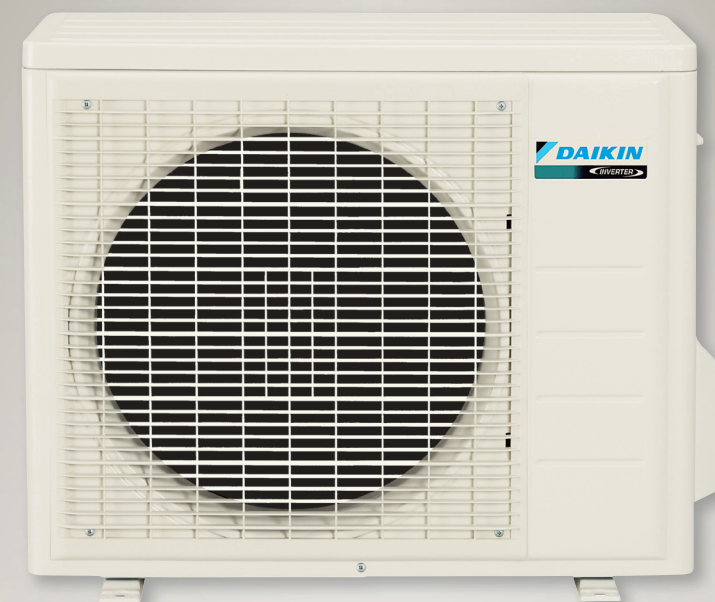

EEDEN11-100

RXN25-60K

TABLE OF CONTENTS

RXN-K

1	Features	2
2	Specifications	3
	Nominal Capacity And Nominal Input	3
	Technical Specifications	3
	Electrical Specifications	4
3	Options	5
4	Electrical data	6
	Electrical Data	6
5	Capacity tables	7
	Cooling/Heating Capacity Tables	7
6	Dimensional drawings	11
	Dimensional Drawings	11
7	Centre of gravity	12
	Centre of Gravity	12
8	Piping diagrams	14
	Piping Diagrams	14
9	Wiring diagrams	16
	Wiring Diagrams - Single Phase	16
10	Sound data	17
	Sound Pressure Spectrum	17
11	Operation range	19
	Operation Range	19

1 Features

- Outdoor units for pair application
- Outdoor units are fitted with a swing compressor, renowned for its low noise and high energy efficiency
- Daikin outdoor units are neat, sturdy and can easily be mounted on a roof or terrace or simply placed against an outside wall

1

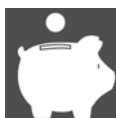

2 Specifications

2-1 Nominal Capacity And Nominal Input				FTXN25KEV1B / RXN25KEV1B	FTXN35KEV1B / RXN35KEV1B	FTXN50KEV1B / RXN50KEV1B	FTXN60KEV1B / RXN60KEV1B
Cooling capacity	Nom.		kW	2.5 (3)	3.20 (3)	5.0 (3)	6.0 (3)
Heating capacity	Nom.		kW	2.8 (4)	3.5 (4)	5.5 (4)	6.3 (4)
Power input	Cooling	Nom.	kW	0.795	1.060	1.560	1.990
	Heating	Nom.	kW	0.82	1.020	1.570	1.850
Piping connections	Liquid	OD	mm	6.35			
	Gas	OD	mm	9.5		12.7	
	Heat insulation			Both liquid and gas pipes			
Current	Nominal running current (RLA) - 50Hz	Cooling	A	3.8 (5) 3.6 (6) 3.5 (7)	4.9 (5) 4.7 (6) 4.5 (7)	-	
		Heating	A	3.9 (5) 3.7 (6) 3.5 (7)	4.7 (5) 4.5 (6) 4.3 (7)	-	

Notes

- (1) Energy label: scale from A (most efficient) to G (less efficient)
- (2) Annual energy consumption: based on average use of 500 running hours per year at full load (nominal conditions)
- (3) Cooling: indoor temp. 27°CDB, 19°CWB; outdoor temp. 35°CDB, 24°CWB
- (4) Heating: indoor temp. 20°CDB; outdoor temp. 7°CDB, 6°CWB
- (5) 220V
- (6) 230V
- (7) 240V

2-2 Technical Specifications				RXN25KEV1B	RXN35KEV1B	RXN50KEV1B	RXN60KEV1B	
Casing	Colour			Ivory white				
Dimensions	Unit	Height	mm	550		595		
		Width	mm	658		795		
		Depth	mm	275		300		
	Packed unit	Height	mm	592		654		
		Width	mm	771		942		
		Depth	mm	348		400		
Weight	Unit		kg	26	28	42		
	Packed unit		kg	30	32	45		
Packing	Weight		kg	4		-		
Heat exchanger	Length		mm	670	647	870		
	Rows	Quantity		1	2			
	Fin pitch		mm	1.4				
	Stages	Quantity		12	24	26		
	Tube type			ø7 Hi-XD		ø8 Hi-XA		
	Fin	Type		WF fin		Waffle louvered fin		
Fan	Type			Propeller fan				
	Air flow rate	Cooling	High	m³/min	28.8		42.6	48.2
				cfm	1,017		1,504	1,702
		Super low	High	m³/min	-		37.6	42.6
				cfm	-		1,328	1,504
	Heating	High	High	m³/min	28.8		38.3	43.4
				cfm	1,017		1,352	1,532
		Super low	High	m³/min	-		33.8	38.3
cfm				-		1,193	1,352	
Fan motor	Model			JF-220-20-6-1		KFD-280-60-8C		
	Output		W	20		60		
	Speed	Cooling	High	rpm	930		900	1,010
			Super low	rpm	-		800	900
		Heating	High	rpm	930		900	1,010
			Super low	rpm	-		800	900
Sound power level	Cooling	High	dBA	61	63	66		
Sound pressure level	Cooling	High	dBA	47	49	52		
		Silent operation	dBA	-		46	49	
	Heating	High	dBA	48	50	51	52	
		Silent operation	dBA	-		48	49	

2 Specifications

2-2 Technical Specifications					RXN25KEV1B	RXN35KEV1B	RXN50KEV1B	RXN60KEV1B	
Compressor	Model		1YC23AJXD		2YC36BXD				
	Type		Hermetically sealed swing compressor						
	Output		W		600		1,100		
Operation range	Cooling	Ambient	Min.	°CDB	-		10		
			Max.	°CDB	-		46		
	Heating	Ambient	Min.	°CWB	-		-15		
			Max.	°CWB	-		18		
Refrigerant	Type		R-410A						
	Charge		kg		0.74		0.95		
Refrigerant oil	Type		FVC50K						
	Charged volume		l		0.375		0.65		
Piping connections	Liquid	OD	mm		-		6.35		
	Gas	OD	mm		-		12.7		
	Drain	Type		-					
		ID		mm		-		18.0	
	Piping length	OU - IU	Max.	m		15		30	
		System	Charge-less	m		10		-	
	Level difference	IU - OU	Max.	m		12		20	
Heat insulation		-						Both liquid and gas pipes	

2-3 Electrical Specifications					RXN25KEV1B	RXN35KEV1B	RXN50KEV1B	RXN60KEV1B				
Power supply	Phase		1~									
	Frequency		Hz		50							
	Voltage		V		220-240							
Current	Nominal running current (RLA)	Cooling	A		3.65 (1) 3.45 (2) 3.34 (3)		4.75 (1) 4.55 (2) 4.34 (3)		7.14 (1) 6.75 (2) 6.55 (3)		9.01 (1) 8.62 (2) 8.23 (3)	
		Heating	A		3.75 (1) 3.55 (2) 3.34 (3)		4.55 (1) 4.35 (2) 4.14 (3)		7.13 (1) 6.84 (2) 6.54 (3)		8.29 (1) 8.0 (2) 7.61 (3)	
	Starting current	Cooling	A		3.9		4.9		7.3		9.2	
		Heating	A		3.9		4.9		7.3		9.2	
Wiring connections	For power supply	Quantity		-		-		3				
	For connection with indoor	Quantity		-		-		4				
	Remark		-						Earth wire included			

Notes

(1) 220V

(2) 230V

(3) 240V

(4) SL: The silent fan level of the air flow rate setting

3 Options

RXN25-35K

	Description	Option name
Outdoor unit	Air Direction Adjustment Grille	KPW937B4
	Drain plug	KKP937A4

RXN50-60K

	Description	Option name
Outdoor unit	Air Direction Adjustment Grille	KPW937C4
	Drain plug	KKP937A4

4 Electrical data

4 - 1 Electrical Data

4

RXN25-35K

Representative unit combination		Power supply				Comp.		OFM		IFM	
Indoor unit	Outdoor unit	Hz-volts	Voltage range	MCA	MFA	RLA	W	FLA	W	FLA	
FTXN25KEV1B	RXN25KEV1B	50 - 220	Max. 50Hz 264V Min. 50Hz 198V	7,5	16	3,4	20	0,21	15	0,15	
		50 - 230				3,2		0,22		0,15	
		50 - 240				3,1		0,22		0,16	
FTXN35KEV1B	RXN35KEV1B	50 - 220	Max. 50Hz 264V Min. 50Hz 198V	8,5	16	4,5	20	0,21	15	0,15	
		50 - 230				4,2		0,22		0,15	
		50 - 240				4,0		0,22		0,16	

3D071887

SYMBOLS

- MCA : Min. Circuit Amps (A)
- MFA : Max. Fuse Amps (A)
- RLA : Rated Load Amps (A)
- OFM : Outdoor Fan Motor
- IFM : Indoor Fan Motor
- FLA : Full Load Amps (A)
- W : Fan Motor Rated Output (W)

NOTES

1. Maximum allowable voltage variation between phases is 2%
2. Select wire size based on the larger value of MCA.
3. Instead of fuse, use Circuit Breaker.

5 Capacity tables

5 - 1 Cooling/Heating Capacity Tables

FTXN25KEV1B + RXN25KEV1B

Cooling

50Hz 220-240V

Temp: Celsius / TC, SHC, Pl: kW

AFR	9.2
BF	0.20

Indoor		Outdoor temperature (°CDB)																	
EWB (°C)	EDB (°C)	20			25			30			32			35			40		
		TC	SHC	PI	TC	SHC	PI	TC	SHC	PI	TC	SHC	PI	TC	SHC	PI	TC	SHC	PI
14.0	20.0	2.42	1.94	0.59	2.42	1.94	0.67	2.33	1.89	0.73	2.28	1.87	0.75	2.21	1.84	0.79	2.10	1.78	0.84
16.0	22.0	2.68	1.97	0.61	2.56	1.92	0.67	2.44	1.86	0.73	2.40	1.84	0.75	2.33	1.81	0.79	2.21	1.76	0.85
18.0	25.0	2.79	2.08	0.62	2.68	2.03	0.68	2.56	1.98	0.73	2.51	1.96	0.76	2.44	1.93	0.79	2.33	1.88	0.85
19.0	27.0	2.85	2.20	0.62	2.73	2.16	0.68	2.62	2.11	0.74	2.57	2.09	0.76	2.50	2.06	0.80	2.38	2.02	0.85
22.0	30.0	3.02	2.13	0.62	2.91	2.09	0.68	2.79	2.05	0.74	2.74	2.03	0.77	2.67	2.01	0.80	2.56	1.97	0.86
24.0	32.0	3.14	2.08	0.63	3.02	2.04	0.69	2.90	2.00	0.75	2.86	1.99	0.77	2.79	1.97	0.80	2.67	1.93	0.86

Heating

50Hz 220-240V

Temp: Celsius / TC, Pl: kW

AFR	9.8
-----	-----

Indoor		Outdoor temperature (°CWB)											
EDB (°C)	TC	-15		-10		-5		0		6		10	
		TC	PI	TC	PI	TC	PI	TC	PI	TC	PI	TC	PI
15.0	1.33	0.53	1.60	0.55	1.87	0.58	2.52	0.76	2.90	0.80	3.15	0.83	
20.0	1.25	0.54	1.52	0.57	1.79	0.60	2.42	0.78	2.80	0.82	3.05	0.85	
22.0	1.22	0.55	1.49	0.58	1.76	0.60	2.38	0.79	2.76	0.83	3.01	0.85	
24.0	1.19	0.55	1.45	0.58	1.72	0.61	2.34	0.79	2.72	0.83	2.98	0.86	
25.0	1.17	0.56	1.44	0.58	1.71	0.61	2.32	0.80	2.70	0.84	2.96	0.87	
27.0	1.14	0.56	1.41	0.59	1.67	0.62	2.29	0.81	2.66	0.85	2.92	0.87	

3D071876

SYMBOLS

AFR:	Air flow rate	(m ³ /min)
BF:	Bypass factor	
EWB:	Entering wet bulb temp.	(°C)
EDB:	Entering dry bulb temp.	(°C)
TC:	Total capacity	(kW)
SHC:	Sensible heating capacity	(kW)
PI:	Power input	(kW)

NOTES

1. Ratings shown are net capacities which include a deduction for indoor fan motor heat.
2. shows nominal (rated) capacities and power input.
3. TC, PI and SHC must be calculated by interpolation using the figures in the above tables. (Figures out of the tables should not be used for calculation.)
4. About SHC which are not mentioned on the table, please calculate them with around values in direct proportion.
5. Capacities are based on the following conditions:
Corresponding refrigerant piping length : 5m
Level difference : 0m
6. Air flow rate (AFR) and Bypass factor (BF) are tabulated above table.

5 Capacity tables

5 - 1 Cooling/Heating Capacity Tables

5

FTXN35KEV1B + RXN35KEV1B

Cooling

50Hz 220-240V

Temp: Celsius / TC, SHC, PI:kW

AFR	9,6
BF	0,24

Indoor		Outdoor temperature (°CDB)																	
EWB (°C)	EDB (°C)	20			25			30			32			35			40		
		TC	SHC	PI	TC	SHC	PI	TC	SHC	PI	TC	SHC	PI	TC	SHC	PI	TC	SHC	PI
14.0	20.0	2.40	1.92	0.81	2.40	1.92	0.89	2.40	1.92	0.97	2.40	1.92	1.00	2.40	1.92	1.05	2.40	1.92	1.13
16.0	22.0	3.21	2.21	0.82	3.21	2.21	0.90	3.13	2.17	0.97	3.07	2.14	1.01	2.98	2.10	1.05	2.83	2.03	1.13
18.0	25.0	3.57	2.41	0.82	3.42	2.35	0.90	3.28	2.28	0.98	3.22	2.25	1.01	3.13	2.21	1.06	2.98	2.15	1.14
19.0	27.0	3.65	2.53	0.82	3.50	2.47	0.90	3.35	2.40	0.98	3.29	2.38	1.01	3.20	2.34	1.06	3.05	2.28	1.14
22.0	30.0	3.87	2.44	0.83	3.72	2.38	0.91	3.57	2.32	0.99	3.51	2.30	1.02	3.42	2.27	1.07	3.27	2.21	1.15
24.0	32.0	4.02	2.37	0.84	3.87	2.32	0.91	3.72	2.27	0.99	3.66	2.25	1.02	3.57	2.21	1.07	3.42	2.16	1.15

Heating

50Hz 220-240V

Temp: Celsius / TC, PI:kW

AFR	10,1
-----	------

Indoor		Outdoor temperature (°CWB)											
EDB (°C)		-15		-10		-5		0		6		10	
		TC	PI	TC	PI	TC	PI	TC	PI	TC	PI	TC	PI
15.0		1.67	0.66	2.00	0.69	2.34	0.72	3.15	0.95	3.62	1.00	3.94	1.03
20.0		1.56	0.67	1.90	0.71	2.24	0.74	3.03	0.97	3.50	1.02	3.82	1.05
22.0		1.52	0.68	1.86	0.72	2.19	0.75	2.98	0.98	3.45	1.03	3.77	1.06
24.0		1.48	0.68	1.82	0.72	2.15	0.76	2.93	0.99	3.40	1.04	3.72	1.07
25.0		1.46	0.68	1.80	0.73	2.13	0.76	2.90	0.99	3.38	1.04	3.70	1.08
27.0		1.42	0.70	1.76	0.73	2.09	0.77	2.86	1.00	3.33	1.05	3.65	1.09

3D071877

SYMBOLS

AFR:	Air flow rate	(m ³ /min)
BF:	Bypass factor	
EWB:	Entering wet bulb temp.	(°C)
EDB:	Entering dry bulb temp.	(°C)
TC:	Total capacity	(kW)
SHC:	Sensible heating capacity	(kW)
PI:	Power input	(kW)

NOTES

- Ratings shown are net capacities which include a deduction for indoor fan motor heat.
- shows nominal (rated) capacities and power input.
- TC, PI and SHC must be calculated by interpolation using the figures in the above tables. (Figures out of the tables should not be used for calculation.)
- About SHC which are not mentioned on the table, please calculate them with around values in direct proportion.
- Capacities are based on the following conditions:
Corresponding refrigerant piping length : 5m
Level difference : 0m
- Air flow rate (AFR) and Bypass factor (BF) are tabulated above table.

5 Capacity tables

5 - 1 Cooling/Heating Capacity Tables

°	°																		
14.0	20	5.12	3.78	1.20	4.89	3.67	1.31	4.66	3.55	1.43	4.56	3.50	1.47	4.42	3.44	1.54	4.19	3.32	1.66
16.0	22	5.35	3.72	1.20	5.12	3.61	1.32	4.89	3.50	1.43	4.79	3.46	1.48	4.65	3.39	1.55	4.42	3.29	1.66
18.0	25	5.58	3.89	1.21	5.35	3.79	1.33	5.12	3.69	1.44	5.02	3.65	1.49	4.88	3.59	1.56	4.65	3.49	1.67
19.0	27	5.70	4.10	1.21	5.47	4.00	1.33	5.23	3.90	1.44	5.14	3.87	1.49	5.00	3.81	1.56	4.77	3.71	1.68
22.0	30	6.04	3.95	1.22	5.81	3.87	1.34	5.58	3.78	1.46	5.49	3.75	1.50	5.35	3.70	1.57	5.11	3.61	1.69
24.0	32	6.27	3.85	1.23	6.04	3.77	1.35	5.81	3.69	1.46	5.72	3.66	1.51	5.58	3.61	1.58	5.34	3.54	1.69

°											
15.0		3.70	1.33	4.32	1.39	4.94	1.46	5.69	1.53	6.19	1.59
20.0		3.51	1.36	4.13	1.43	4.75	1.49	5.50	1.57	6.00	1.62
22.0		3.44	1.38	4.06	1.44	4.68	1.51	5.42	1.58	5.92	1.64
24.0		3.36	1.39	3.98	1.46	4.60	1.52	5.35	1.60	5.84	1.65
25.0		3.32	1.40	3.94	1.46	4.56	1.53	5.31	1.61	5.81	1.66
27.0		3.25	1.41	3.87	1.48	4.49	1.54	5.23	1.62	5.73	1.67

5 Capacity tables

5 - 1 Cooling/Heating Capacity Tables

5

°C		°F																	
14.0	20	6.15	4.37	1.53	5.87	4.22	1.67	5.59	4.08	1.82	5.48	4.02	1.88	5.31	3.94	1.97	5.03	3.80	2.12
16.0	22	6.42	4.29	1.54	6.14	4.16	1.68	5.86	4.02	1.83	5.75	3.97	1.89	5.59	3.89	1.98	5.31	3.76	2.12
18.0	25	6.70	4.47	1.54	6.42	4.34	1.69	6.14	4.21	1.84	6.03	4.16	1.90	5.86	4.09	1.99	5.58	3.96	2.13
19.0	27	6.84	4.68	1.55	6.56	4.56	1.70	6.28	4.43	1.84	6.17	4.39	1.90	6.00	4.31	1.99	5.72	4.20	2.14
22.0	30	7.25	4.50	1.56	6.97	4.39	1.71	6.69	4.28	1.86	6.58	4.24	1.91	6.41	4.18	2.00	6.14	4.07	2.15
24.0	32	7.53	4.37	1.57	7.25	4.27	1.72	6.97	4.17	1.86	6.86	4.14	1.92	6.69	4.08	2.01	6.41	3.98	2.16

°C		°F									
15.0	4.24	1.56	4.95	1.64	5.66	1.72	6.52	1.81	7.09	1.87	
20.0	4.02	1.61	4.73	1.68	5.45	1.76	6.30	1.85	6.87	1.91	
22.0	3.94	1.62	4.65	1.70	5.36	1.78	6.21	1.87	6.78	1.93	
24.0	3.85	1.64	4.56	1.72	5.27	1.79	6.13	1.88	6.70	1.94	
25.0	3.81	1.65	4.52	1.72	5.23	1.80	6.08	1.89	6.65	1.95	
27.0	3.72	1.66	4.43	1.74	5.14	1.82	6.00	1.91	6.46	1.97	

6 Dimensional drawings

6 - 1 Dimensional Drawings

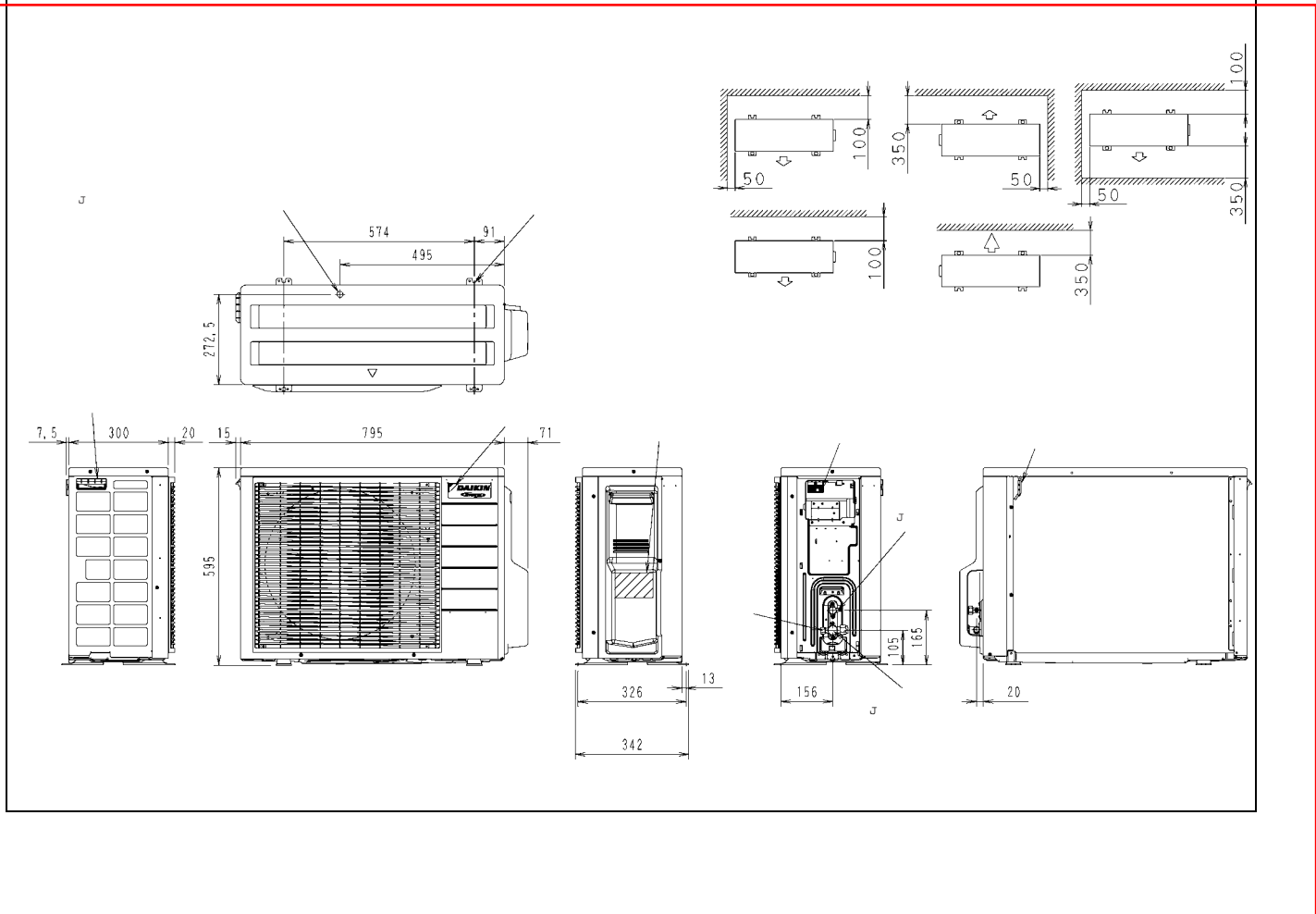
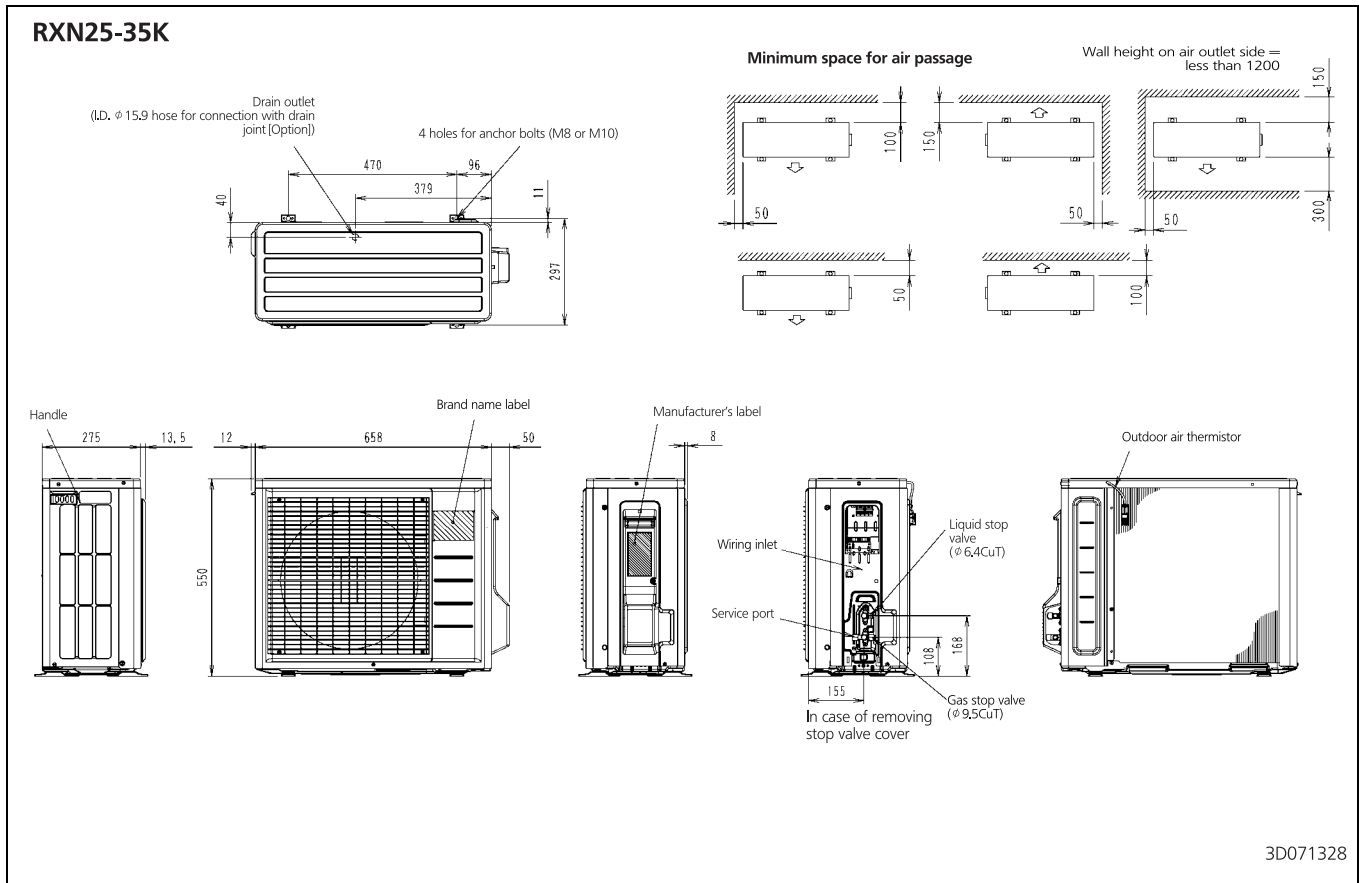

7 Centre of gravity

7 - 1 Centre of Gravity

7

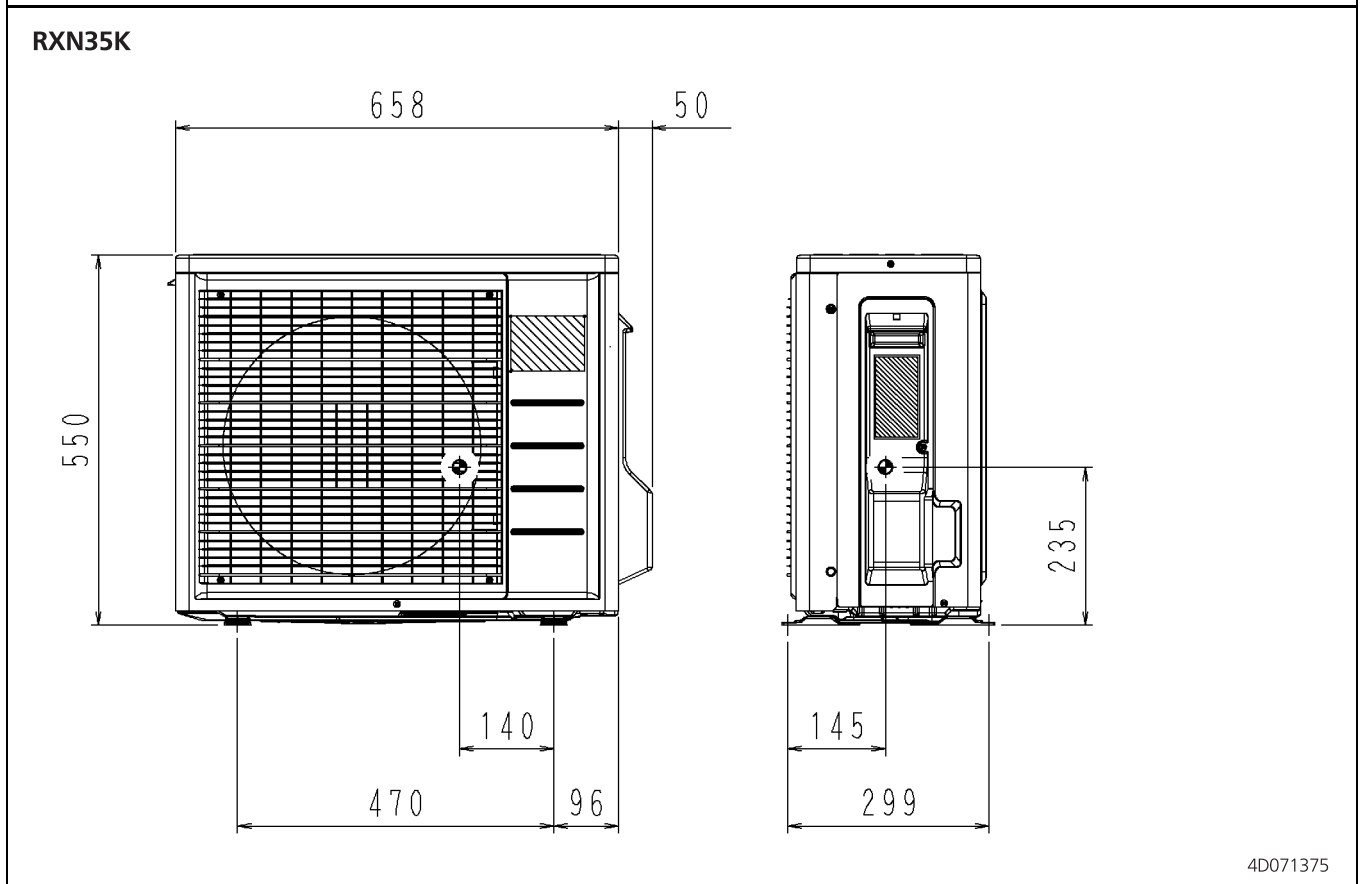
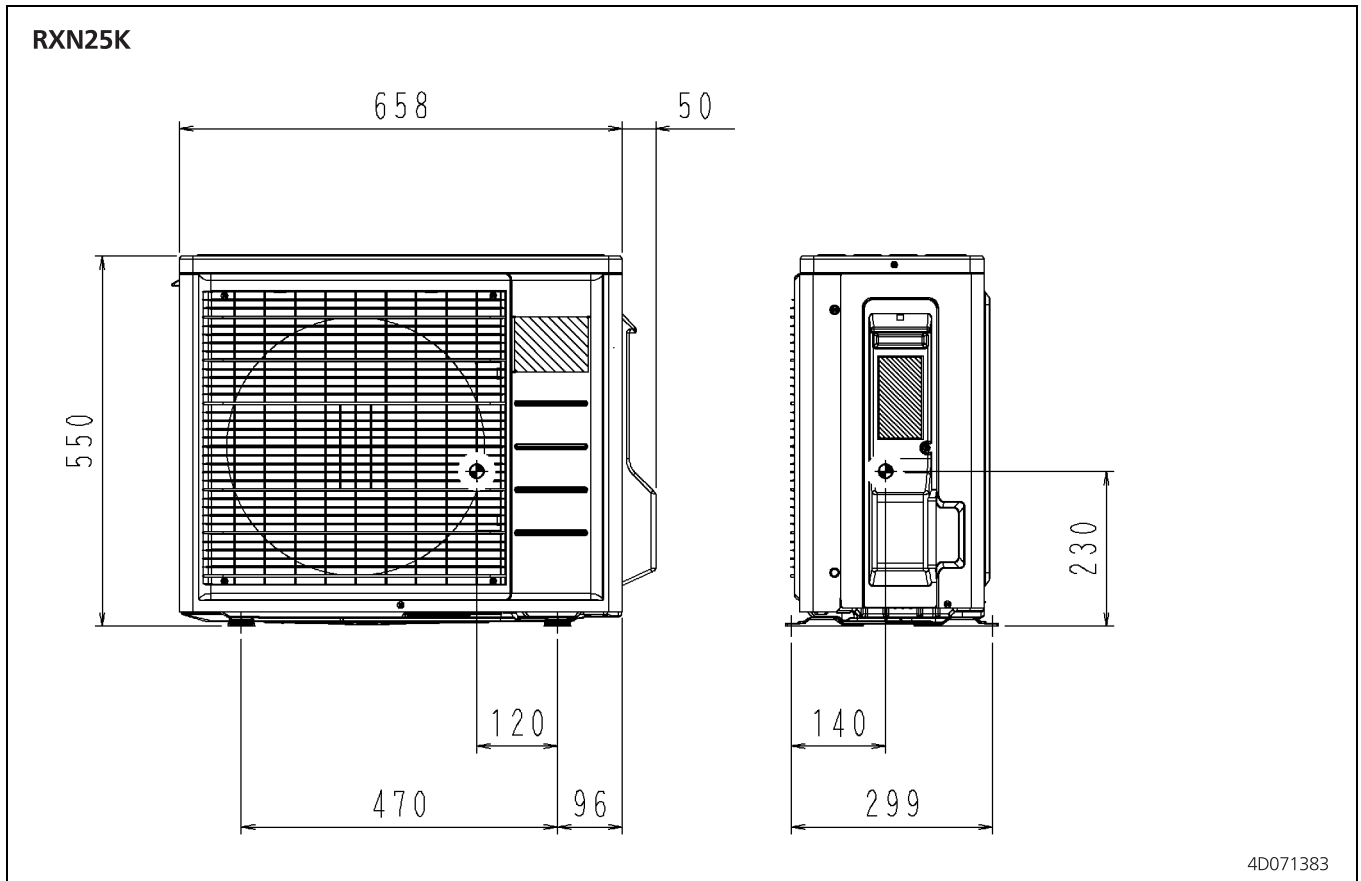

7 Centre of gravity

7 - 1 Centre of Gravity

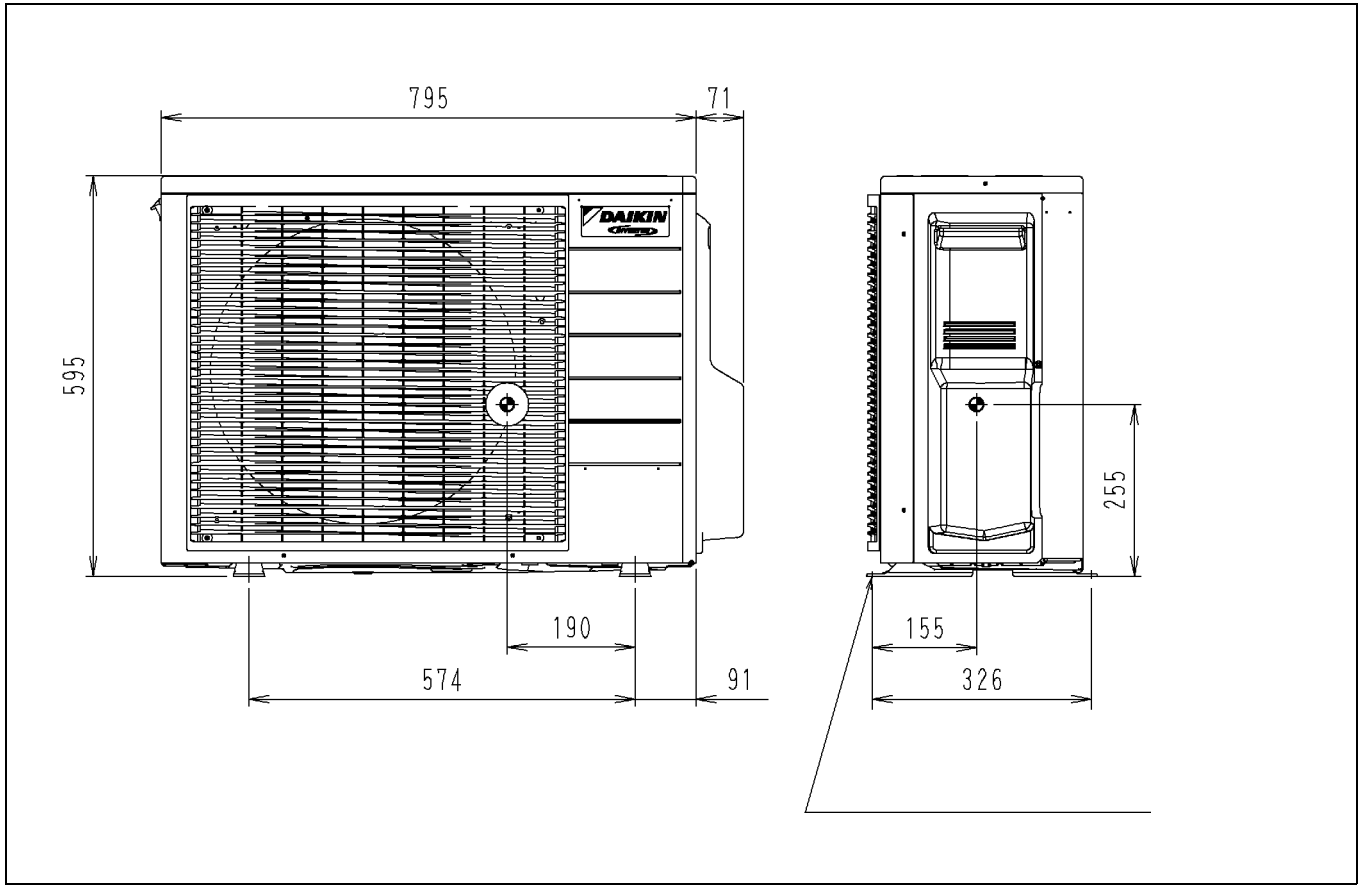

8 Piping diagrams

8 - 1 Piping Diagrams

8

RXN25K

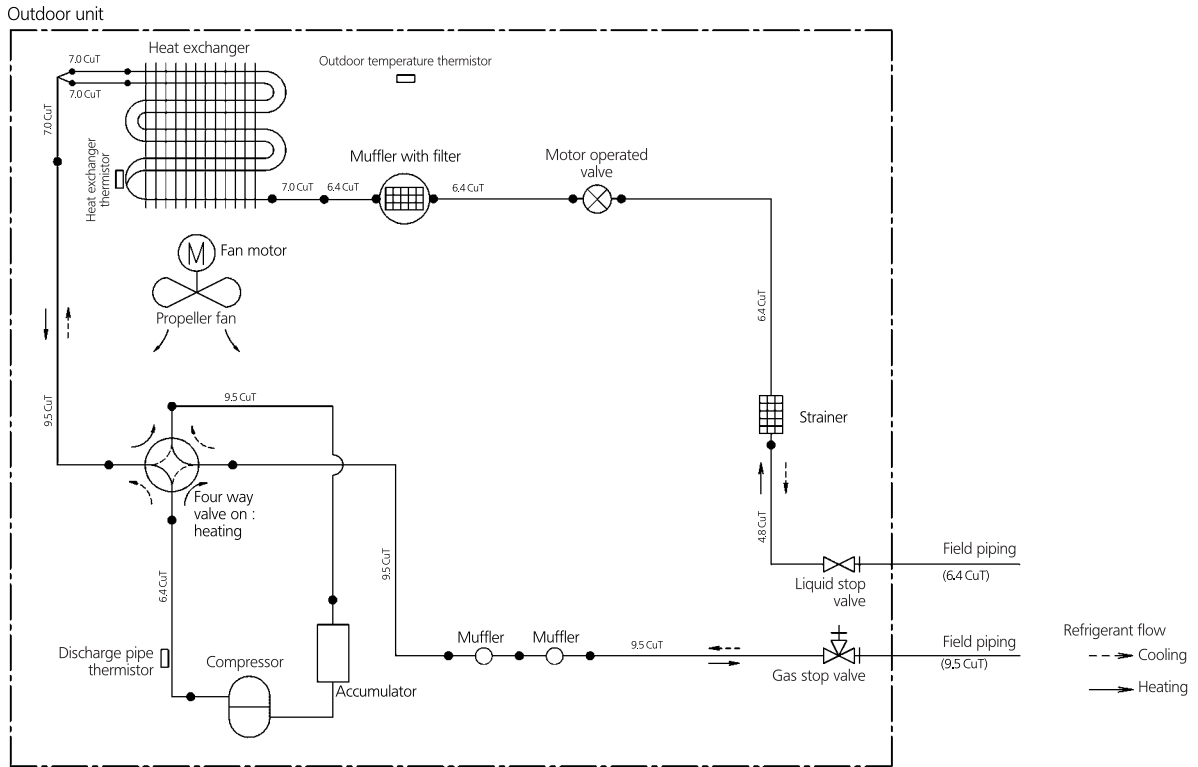

3D066213A

RXN35K

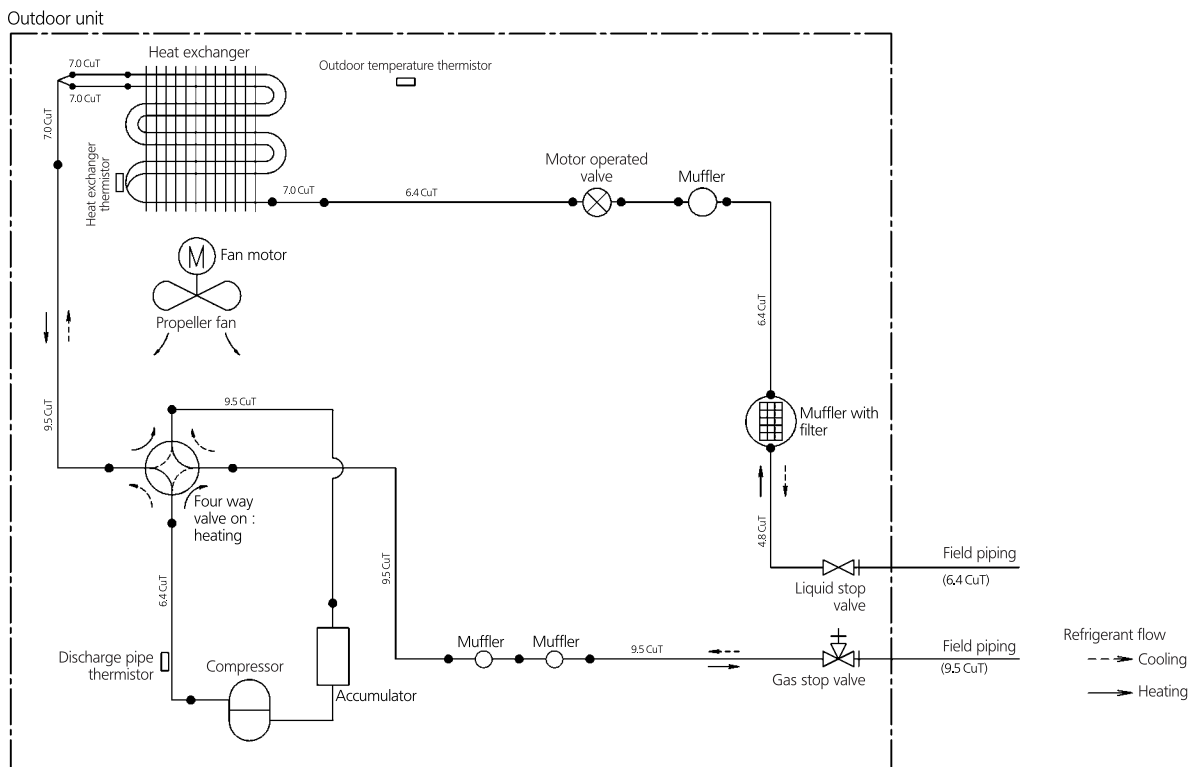

3D071264

8 Piping diagrams

8 - 1 Piping Diagrams

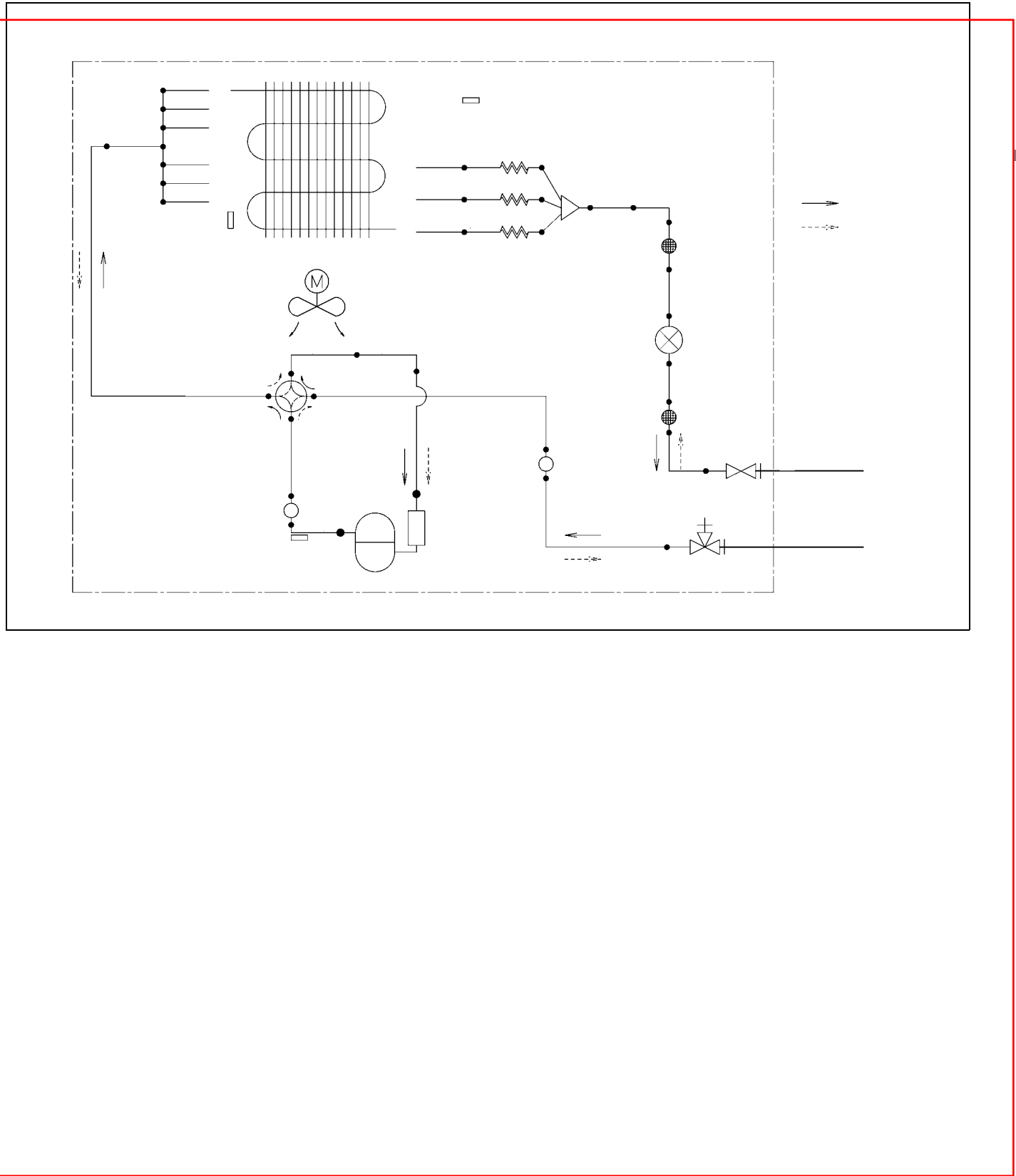

9 Wiring diagrams

9 - 1 Wiring Diagrams - Single Phase

RXN25-35K

185

105

Notes)
 1. Size: Length 105 X Width 185.
 2. refer to purchasing specifications as (Y)303002, unless otherwise specified.
 3. This drawing was drawn on CAD system.

Wiring diagram

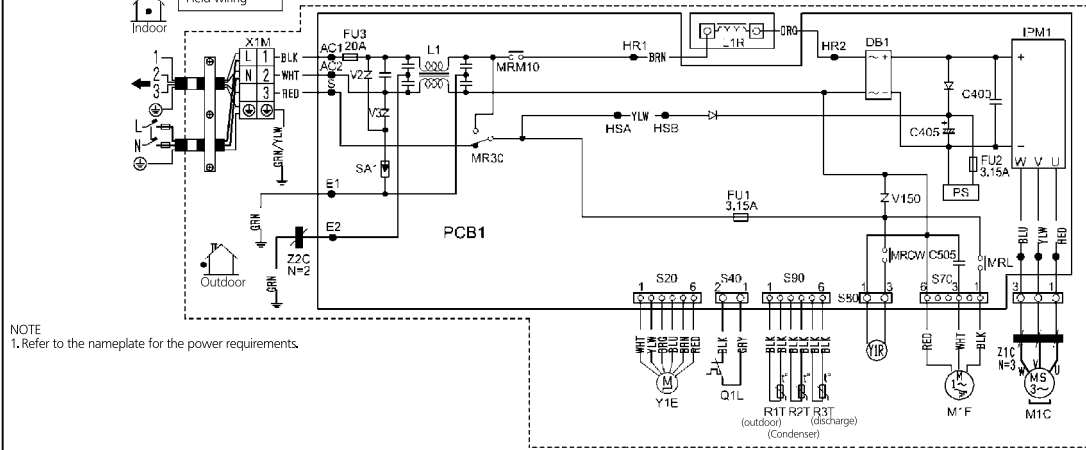

NOTE
 1. Refer to the nameplate for the power requirements.

- | | | | | | |
|----------------|----------------------------|-------------|-------------------------|------------|-----------------------------------|
| C400,C405,C505 | : Capacitor | Q1L | : Overload protector | X1M | : Terminal strip |
| DB1 | : Diode bridge | PCB1 | : Printed circuit board | Y1E | : Electronic expansion valve coil |
| FU1,FU2,FU3 | : Fuse | S20,S40,S70 | : Connector | Y1R | : Reversing solenoid valve coil |
| IPM1 | : Intelligent power module | S80,S90 | : Connector | Z1C,Z2C | : Ferrite core |
| L1 | : Coil | R1T,R2T,R3T | : Thermistor | PS | : Power supply |
| L1R | : Reactor | SA1 | : Surge armerster | V2,V3,V150 | : Varistor |
| M1C | : Compressor motor | | | | |
| M1F | : Fan motor | | | | |
| MR30,MRM10 | : Magnetic relay | | | | |
| MRCW,MRL | : Magnetic relay | | | | |

3D070554A

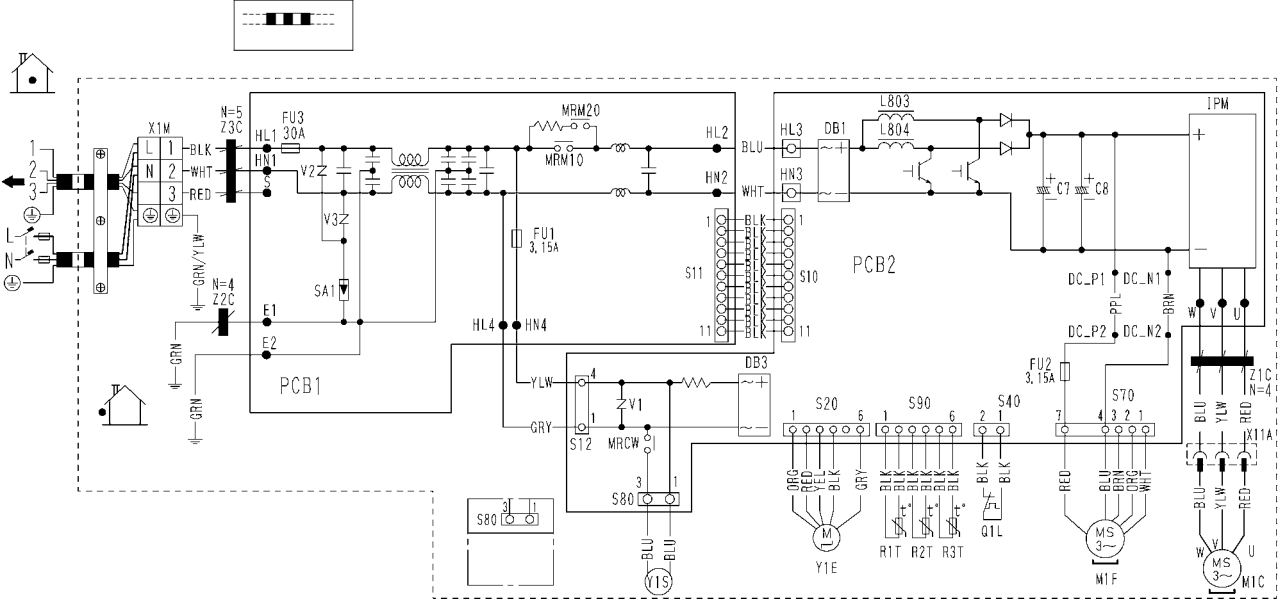

10 Sound data

10 - 1 Sound Pressure Spectrum

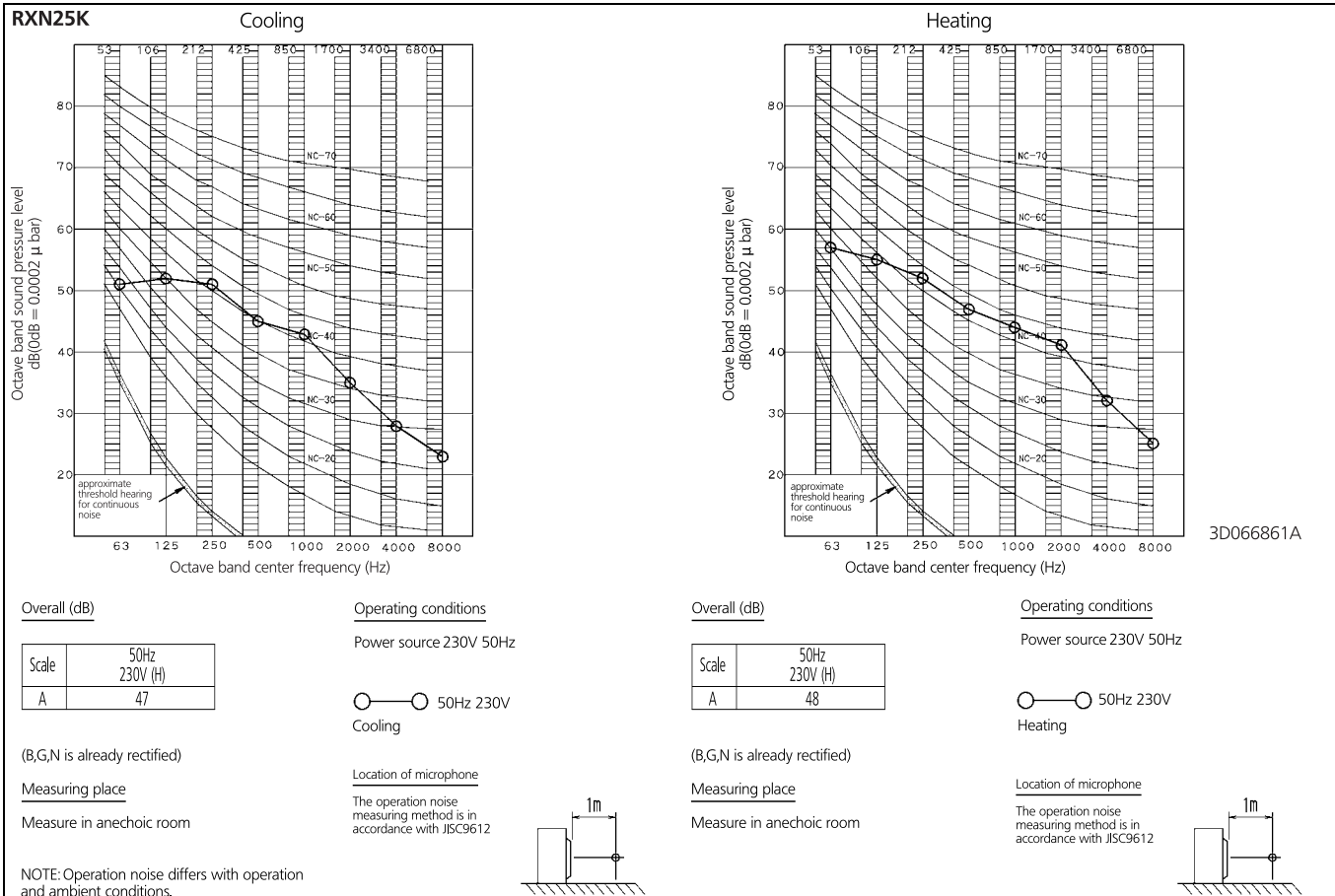

3D066861A

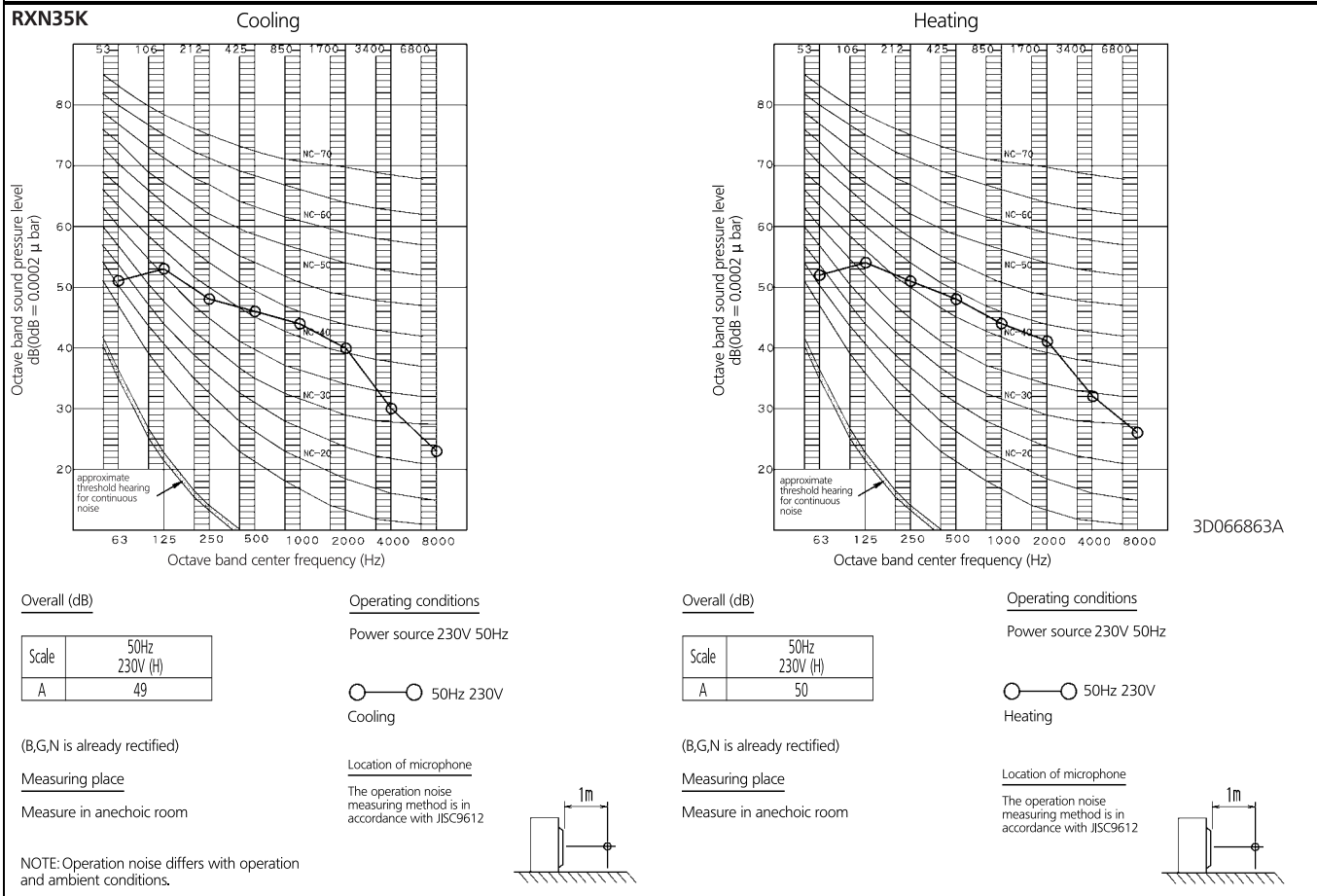

3D066863A

10 Sound data

10 - 1 Sound Pressure Spectrum

10

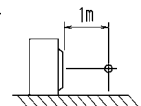
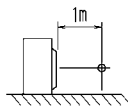
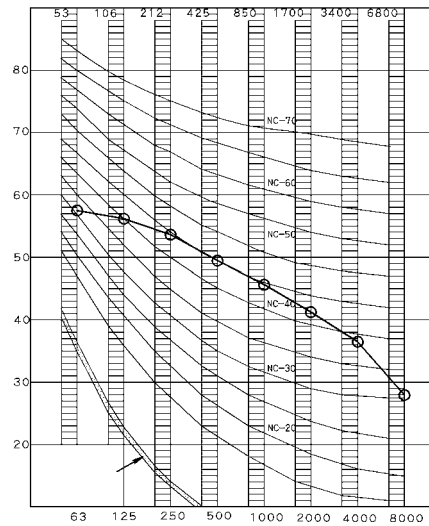
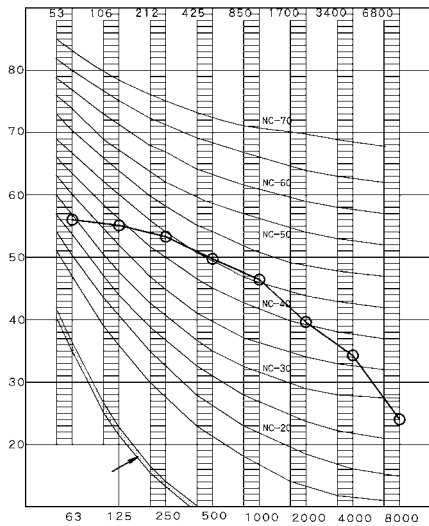
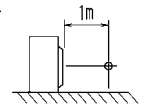
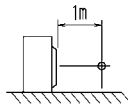
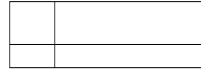
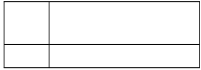
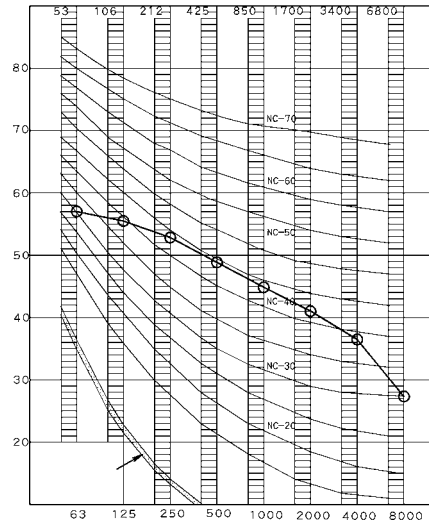
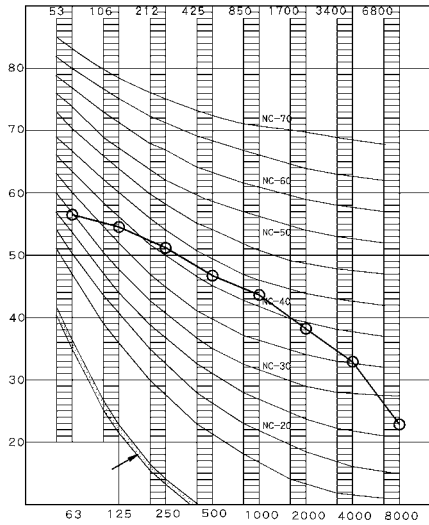

11 Operation range

11 - 1 Operation Range

RXN25-35K

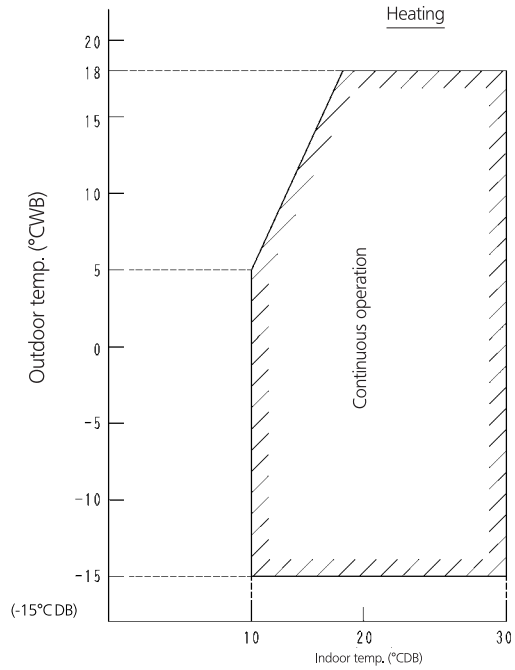
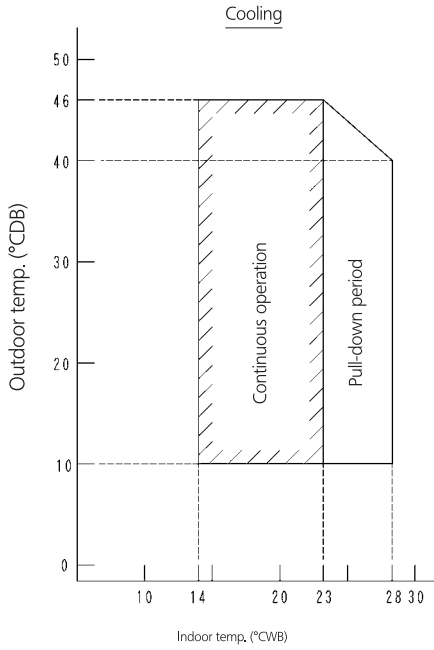

Notes:
 The graphs are based on the following conditions:
 • Equivalent piping length 5 m
 • Level difference 0 m
 • Air flow rate high

3D071996

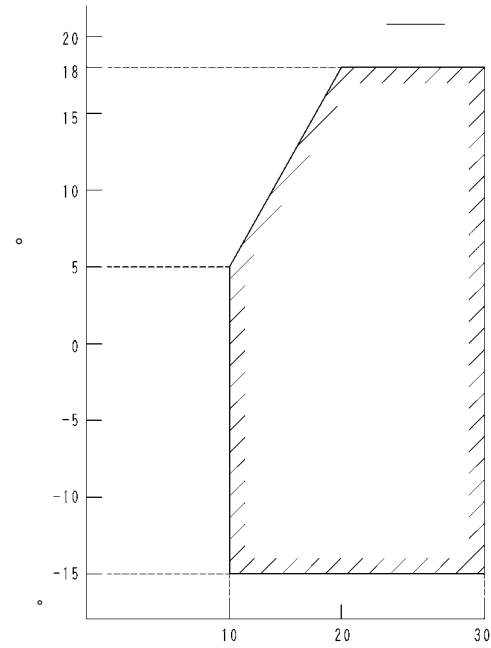
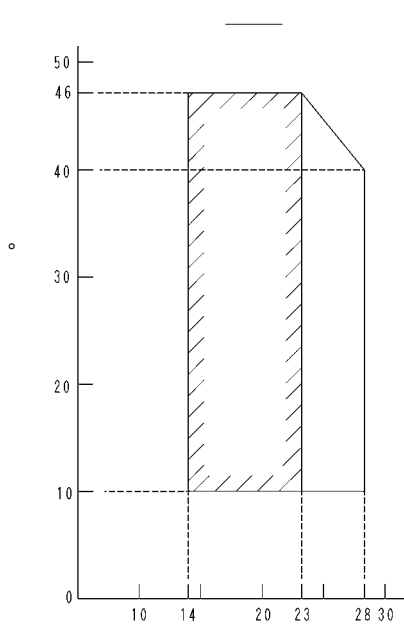

•
•
•