



INSTALLATION MANUAL

Outdoor unit multi connection piping kit

BHFQM23P907
BHFQM23P1357

! IMPROPER INSTALLATION OR ATTACHMENT OF EQUIPMENT OR ACCESSORIES COULD RESULT IN ELECTRIC SHOCK, SHORT-CIRCUIT, LEAKS, FIRE OR OTHER DAMAGE TO THE EQUIPMENT. BE SURE ONLY TO USE ACCESSORIES MADE BY DAIKIN WHICH ARE SPECIFICALLY DESIGNED FOR USE WITH THE EQUIPMENT AND HAVE THEM INSTALLED BY A PROFESSIONAL. IF UNSURE OF INSTALLATION PROCEDURES OR USE, ALWAYS CONTACT YOUR DAIKIN DEALER FOR ADVICE AND INFORMATION.

This kit includes the following parts

Table 1

Kit name	Suction gas joint	HP/LP gas joint	Liquid joint	Equalizer joint	Shape								
					Suction gas reducer			HP/LP gas reducer		Liquid reducer	Insulation Gas ⁽¹⁾ Liquid		
BHFQM23P907				—	(1)	(2)	(3)	(1)	(2)	(1)			
	1x	1x	1x		1x	1x	1x	1x	1x	1x	2x	1x	
BHFQM23P1357	(1)	(1)	(1)		(1)	(2)	(3)	(1)	(2)	(1)			
	1x	1x	1x		2x	1x	1x	2x	2x	2x			
	(2)	(2)	(2)	1x	(4)	(5)		(3)			4x	2x	
	1x	1x	1x	1x	1x	3x		1x		2x			

(1) For both suction gas pipes and HP/LP gas pipes

Table 2

	Inch-mm reducers								
	(1)	(2)	(3)	(4)	(5)	(6)	(7)	(8)	(9)
BHFQM23P907	2x	2x	4x	2x	2x	2x	2x	4x	2x
BHFQM23P1357	3x	3x	8x	3x	2x	3x	3x	5x	2x

NOTE



- Do not throw away any of the accessories until installation is completed.
- Be sure to read this manual before installation and follow the instructions carefully when performing installation.
- For installation of the outdoor units, refer to the installation manual of the outdoor unit.
- The installation of refrigerant pipes between outdoor and indoor units needs to be arranged by refnet joints and refnet headers, and is to be purchased separately.
- For combination of outdoor units follow Engineering Data.

Field supply parts

Table 3

Parts	Quantity		Selection procedure	
	907	1357		
Insulation for pipes	1 set		See "Pipe size selection and cutting position of the joint" on page 3 and on page 11.	
Connection pipes				
Joint (angle of 90°)	Suction gas pipes	1x	1x	The joint size must be the same as the gas pipe size of the outermost outdoor unit. Refer to "Pipe size selection and cutting position of the joint" on page 3 and page 11.
	HP/LP gas pipes	2x	2x	
	Equalizer pipes	4x	5x	
Tape	1 set		For insulation.	

Selection procedure

Table 4

Number of outdoor units	Kit name
2 units	BHFQM23P907
3 units	BHFQM23P1357



- The quantity and selection procedure for use of joints with an angle of 90° only apply to front connection installations.
- For lower front connection and bottom connection installations, the quantity and selection procedure are different. Please refer to the dedicated instructions.

RESTRICTIONS ON INSTALLING THE MULTI CONNECTION PIPING KIT

- Install the joints horizontally. Do not tilt the joint more than $\pm 15^\circ$ (see view A).

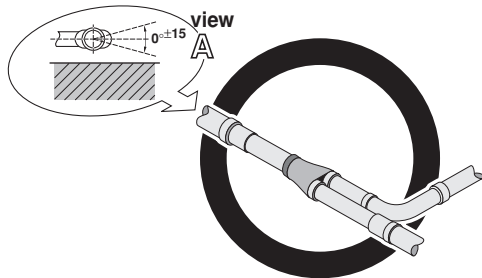

Do not install the joint vertically (see view B).

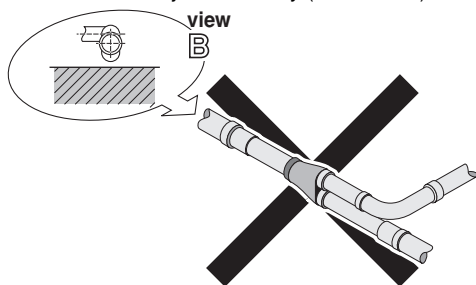

- Make sure that the total length of the piping connected to the joint is absolute straight for more than 500 mm. Only if a straight field piping of more than 120 mm is connected, more than 500 mm of straight section can be ensured.

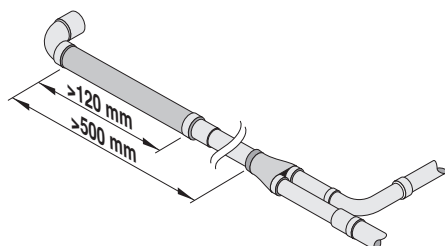

- Improper installation may lead to malfunction of the outdoor unit.



- When installing the multi outdoor system, connect the units as shown in the figure below. If installed in a different order, the outdoor unit multi connection piping kit may not fit properly and some additional field supplied pipe size reducers may be required.

Outdoor unit multi connection piping kit type:

BHFQM23P907

BHFQM23P1357

Unit capacity:

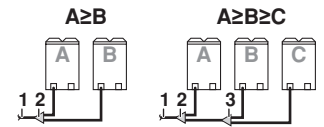

- 1 To indoor unit
- 2 Outdoor unit multi connection piping kit (first branch)
- 3 Outdoor unit multi connection piping kit (second branch)

- If the total capacity of the connected indoor units exceeds the total capacity of the outdoor units, cooling and heating performance may be reduced when running the indoor units. Refer to the capacity table in the Engineering Data Book for more details.



- Use piping with temper grade in function of the pipe diameter as listed in the table below.
- The pipe thickness of the refrigerant piping must comply with relevant local and national regulations. The minimum pipe thickness for R410A piping must be in accordance with the table below (for design pressure of 4.0 MPa (40 bar)).

Pipe Ø	Temper grade											
	O type					1/2H type						
	6.4	9.5	12.7	15.9	19.1	22.2	25.4	28.6	31.8	34.9	38.1	41.3
Minimum thickness t (mm)	0.80	0.80	0.80	1.00	1.00	1.00	1.00	1.00	1.10	1.21	1.32	1.43

O = Annealed
1/2H = Half hard

FOR BHFQM23P907



Refer to the installation manual of the outdoor unit for selection and restrictions for the piping between outdoor branches. Not observing restrictions on the interconnecting piping may result in malfunctioning of the unit.

Pipe size selection and cutting position of the joint

Select the correct pipe size according the tables below and cut the joints and reducers on the correct cutting point with a pipe cutter.

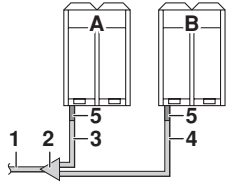

- 1 Main pipe, see table 5 on page 3
- 2 Joint (refer to "Restrictions on installing the multi connection piping kit" on page 2)
- 3 Pipe between joint and the outdoor unit A, see table 6 on page 3
- 4 Pipe between joint and the outdoor unit B, see table 8 on page 3
- 5 Inch-mm reducer (type depending on connection method), see table 7 and table 9 on page 3.

Table 5

- Select the pipe size in function of the total capacity of the outdoor unit.

Total capacity of outdoor units	Pipe size ⁽¹⁾		
	Suction gas	HP/LP gas	Liquid
18 Hp	Ø28x1.0 (1/2H)	Ø22x1.0 (1/2H)	Ø16x1.0 (O)
20~22 Hp	Ø28x1.0 (1/2H)	Ø28x1.0 (1/2H)	Ø16x1.0 (O)
24 Hp	Ø35x1.21 (1/2H)	Ø28x1.0 (1/2H)	Ø16x1.0 (O)
26~32 Hp	Ø35x1.21 (1/2H)	Ø28x1.0 (1/2H)	Ø20x1.0 (1/2H)

(1) OD x minimum wall thickness (temper grade type)

- When upsizing the main pipe, use suction gas reducer (3).
- When using pipes of Ø20 or larger, make sure to use pipes with 1/2H temper grade with a wall thickness of 1.0 mm. In case there is no alternative and you use the O temper grade for pipes with Ø20, a minimal wall thickness of 1.2 mm or more is required and connections need to be brazed.

Upsizing main pipe

For units with total capacity of 24~32 Hp, the suction gas reducer (3) has to be used. Connect the reducer to the suction gas joint as shown in the figure below.

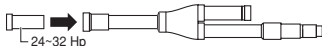

Table 6

Outdoor units	Pipe size ⁽¹⁾			
	Suction gas	HP/LP gas	Equalizer	Liquid
18 Hp	Ø22x1.0 (1/2H)	Ø20x1.0 (1/2H)	Ø20x1.0 (1/2H)	Ø10x0.80 (O)
20~24 Hp	Ø28x1.0 (1/2H)	Ø20x1.0 (1/2H)	Ø20x1.0 (1/2H)	Ø12x0.80 (O)
26~32 Hp	Ø28x1.0 (1/2H)	Ø22x1.0 (1/2H)	Ø20x1.0 (1/2H)	Ø12x0.80 (O)

(1) OD x minimum wall thickness (temper grade type)

Table 7

Outdoor units	Inch-mm reducers (reference (a))							
	Suction gas		HP/LP gas		Equalizer		Liquid	
	(A)	(B)	(A)	(B)	(A)	(B)	(A)	(B)
18 Hp	(2)	(9)	(3)	(8)	(3)	(8)	(5)	(5)
20~24 Hp	(1)	(6)	(3)	(8)	(3)	(8)	(4)	(4)
26~32 Hp	(1)	(6)	(2)	(7)	(3)	(8)	(4)	(4)

(A) Inch-mm reducers for front connection and lower front connection
(B) Inch-mm reducers for bottom connection

Table 8

Outdoor units	Pipe size ⁽¹⁾			
	Suction gas	HP/LP gas	Equalizer	Liquid
18~22 Hp	Ø22x1.0 (1/2H)	Ø20x1.0 (1/2H)	Ø20x1.0 (1/2H)	Ø10x0.80 (O)
24+28 Hp	Ø28x1.0 (1/2H)	Ø20x1.0 (1/2H)	Ø20x1.0 (1/2H)	Ø12x0.80 (O)
26 Hp	Ø22x1.0 (1/2H)	Ø20x1.0 (1/2H)	Ø20x1.0 (1/2H)	Ø10x0.80 (O)
30+32 Hp	Ø28x1.0 (1/2H)	Ø22x1.0 (1/2H)	Ø20x1.0 (1/2H)	Ø12x0.80 (O)

(1) OD x minimum wall thickness (temper grade type)

Table 9

Outdoor units	Inch-mm reducers (reference (b))							
	Suction gas		HP/LP gas		Equalizer		Liquid	
	(A)	(B)	(A)	(B)	(A)	(B)	(A)	(B)
18~22 Hp	(2)	(9)	(3)	(8)	(3)	(8)	(5)	(5)
24 Hp	(1)	(6)	(3)	(8)	(3)	(8)	(4)	(4)
26 Hp	(2)	(9)	(3)	(8)	(3)	(8)	(5)	(5)
28 Hp	(1)	(6)	(3)	(8)	(3)	(8)	(4)	(4)
30+32 Hp	(1)	(6)	(2)	(7)	(3)	(8)	(4)	(4)

(A) Inch-mm reducers for front connection and lower front connection
(B) Inch-mm reducers for bottom connection

- Cut the pipe with a pipe cutter.

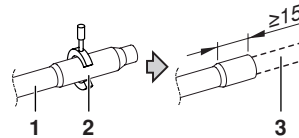

- 1 Joint or reducer
- 2 Cut in order to have a fitting depth of ≥15 mm
- 3 Field pipe

IN CASE OF FRONT PIPING

1. EXTERIOR

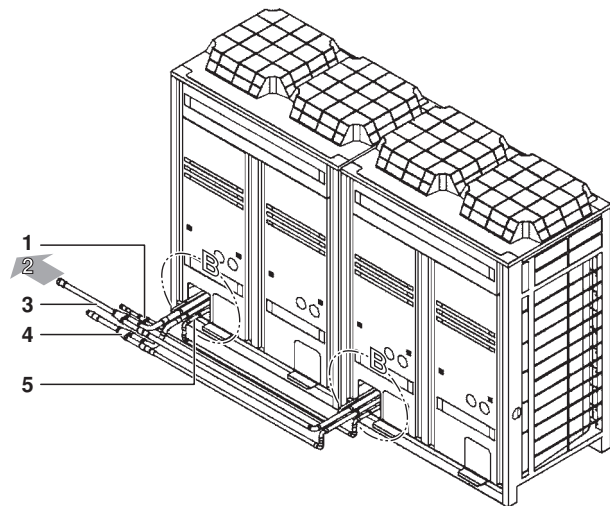

- 1 Liquid joint
- 2 To indoor unit
- 3 Suction gas joint
- 4 HP/LP gas joint
- 5 Equalizer pipe

2. DIMENSIONS FOR INSTALLATION

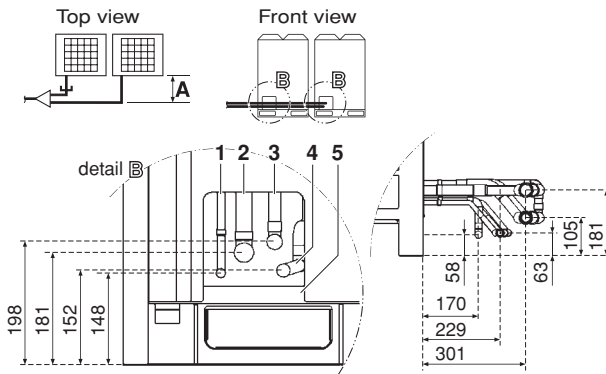

- A 318 mm (standard)
- 1 Liquid pipe
- 2 Suction gas pipe
- 3 HP/LP gas pipe
- 4 Equalizer pipe
- 5 Bottom frame

NOTE In case dimension A exceeds 318 mm, extend the field supplied interconnection piping between the joint and the outdoor unit.

3. INSTALLATION OF SUCTION GAS AND HP/LP GAS PIPES

Cutting the field supplied gas pipes

Use the following tables in case dimension A is 318 mm (refer to "Dimensions for installation" on page 4).

If dimension A exceeds 318 mm, extend the L dimension of the suction gas pipes 1 and 2 and HP/LP gas pipes 1 and 2 accordingly.

■ For suction gas pipes only

For L dimension of suction gas pipes 1 and 2, dimension B of the field supplied angled joint as in table 11 on page 4 has been taken into account. If dimension B of the angled joint you use is different from that dimension B, adjust the L dimension of suction gas pipes 1 and 2 accordingly.

Table 10

Outdoor unit	Pipe 1 L (mm)	Pipe 2 L (mm)
18 Hp	31	208
20+22 Hp	91	208
24 Hp	91	190
26 Hp	91	208
28~32 Hp	91	190

Table 11

Joint (angle of 90°) (field supply)	
Outdoor unit	B (mm)
18~22 Hp	23
24 Hp	29
26 Hp	23
28~32 Hp	29

■ For HP/LP gas pipes only

For L dimension of HP/LP gas pipes 1~3, dimension B of the field supplied angled joint as in table 13 on page 4 has been taken into account. If dimension B of the angled joint you use is different from that dimension B, adjust the L dimension of HP/LP gas pipes 1~3 accordingly.

Table 12

Outdoor unit	Pipe 1 L (mm)	Pipe 2 L (mm)	Pipe 3 L (mm)
18~24 Hp	33	228	59
26+28 Hp	50	228	59
30+32 Hp	50	209	47

Table 13

Joint (angle of 90°) (field supply)	
Outdoor unit	B (mm)
18~28 Hp	17
30+32 Hp	23

Cutting suction gas reducer (1) and HP/LP gas reducer (2)

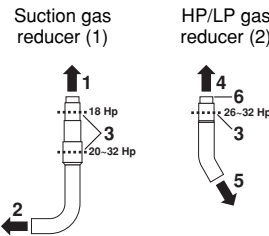

- 1 Connection to suction gas pipe 1 (field supply)
- 2 Connection to suction gas joint
- 3 Cutting position
- 4 Connection to HP/LP gas pipe 1 (field supply)
- 5 Connection to HP/LP gas reducer (1)
- 6 No cutting for 18~24 Hp

Connection piping

- Connect the suction gas and HP/LP gas pipes as shown in the figure below. Before connecting the pipes, first connect the suction gas joint and the suction gas reducer (1), the HP/LP gas joint and the HP/LP gas reducers (1) and (2).
- See "Dimensions for installation" on page 4 for the location (height) of the joint.
- Refer to the installation manual delivered with the outdoor unit for cautions on brazing pipes.
- Keep the joint in a horizontal position, see view A in the figure below.
- Connect the HP/LP gas reducer (1) by tilting it $\pm 50^\circ$ and connect the HP/LP gas reducer (2), see view A in the figure below.
- Refer to "Pipe size selection and cutting position of the joint" on page 3 for the cutting requirements of both joint and reducer.

Cutting liquid reducer (1)

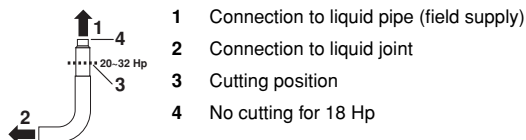

Connection piping

- Connect the liquid pipes and equalizer pipes as shown in the figure below. Before connecting the pipes, first connect the liquid joint and the liquid reducer (1).
- Refer to "Dimensions for installation" on page 4.
- Keep the joint in a horizontal position as shown in view A in the figure below
- Connect the liquid reducer (1) in an angle of 40° and bend the field supplied liquid pipe up to the stop valve as shown in the figure, see view A in the figure below.
- Refer to the installation manual delivered with the outdoor unit for cautions on brazing pipes.
- Refer to "Pipe size selection and cutting position of the joint" on page 3 for the cutting requirements of both joint and reducer.

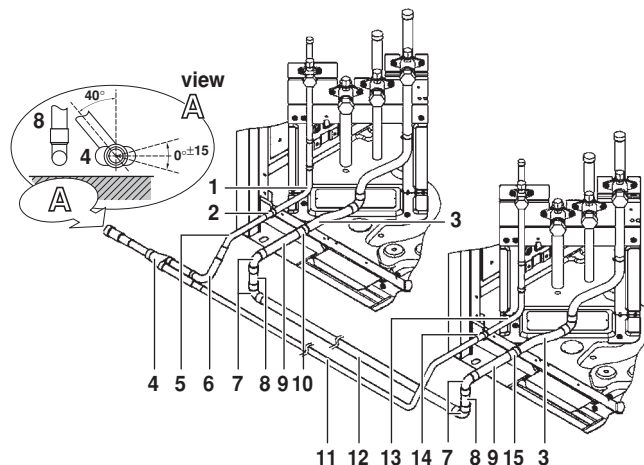

- 1 Liquid accessory pipe (1) supplied with the outdoor unit
- 2 Liquid inch-mm reducer (a) refer to table 7 on page 3
- 3 Equalizer accessory pipe (1) supplied with the outdoor unit
- 4 Liquid joint
- 5 Liquid pipe (1) (field supply) (select the pipe length on site)
- 6 Liquid reducer (1)
- 7 Joint (angle of 90°) (field supply) refer to table 15 on page 5
- 8 Equalizer pipe (2) (field supply) refer to table 14 on page 5
- 9 Equalizer pipe (1) (field supply) refer to table 14 on page 5
- 10 Equalizer inch-mm reducer (a) refer to table 7 on page 3
- 11 Liquid pipe (field supply) (select the pipe length on site)
- 12 Equalizer pipe (field supply) (select the pipe length on site)
- 13 Liquid accessory pipe (2) supplied with the outdoor unit
- 14 Liquid inch-mm reducer (b) refer to table 9 on page 3
- 15 Equalizer inch-mm reducer (b) refer to table 9 on page 3

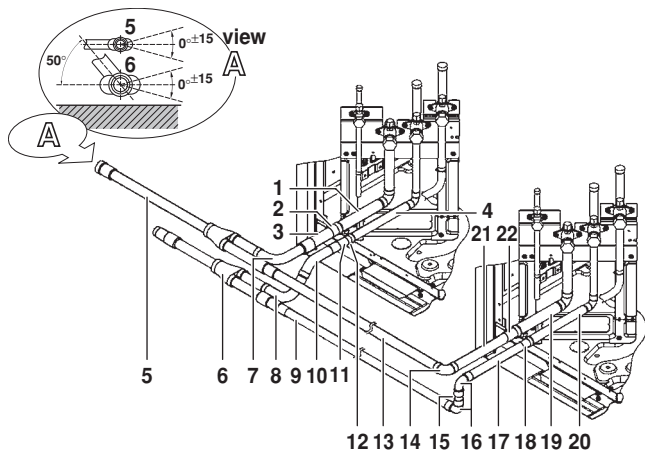

- 1 Suction gas accessory pipe (1) supplied with the outdoor unit
- 2 Suction gas inch-mm reducer (a) refer to table 7 on page 3
- 3 Suction gas pipe (1) (field supply) refer to table 10 on page 4
- 4 HP/LP gas accessory pipe (1) supplied with the outdoor unit
- 5 Suction gas joint
- 6 HP/LP gas joint
- 7 Suction gas reducer (1)
- 8 HP/LP gas reducer (1)
- 9 HP/LP gas pipe (field supply) (select the pipe length on site)
- 10 HP/LP gas reducer (2)
- 11 HP/LP gas pipe (1) (field supply) refer to table 12 on page 4
- 12 HP/LP gas inch-mm reducer (a) refer to table 7 on page 3
- 13 Suction gas pipe (field supply) (select the pipe length on site)
- 14 Joint (1) (angle of 90°) (field supply) refer to table 11 on page 4
- 15 HP/LP gas pipe (3) (field supply) refer to table 12 on page 4
- 16 Joint (2) (angle of 90°) (field supply) refer to table 13 on page 4
- 17 HP/LP gas pipe (2) (field supply) refer to table 12 on page 4
- 18 HP/LP gas inch-mm reducer (b) refer to table 9 on page 3
- 19 Suction gas accessory pipe (2) supplied with the outdoor unit
- 20 HP/LP gas accessory pipe (2) supplied with the outdoor unit
- 21 Suction gas pipe (2) (field supply) refer to table 10 on page 4
- 22 Suction gas inch-mm reducer (b) refer to table 9 on page 3

4. INSTALLATION OF LIQUID PIPES AND EQUALIZER PIPES

Cutting the field supplied equalizer pipes

Use the following tables in case dimension A is 318 mm (refer to "Dimensions for installation" on page 4).

If dimension A exceeds 318 mm, extend the L dimension of the equalizer pipes 1 and 2 accordingly.

For L dimension of equalizer pipes 1 and 2, dimension B of the field supplied angled joint as in table 15 on page 5 has been taken into account. If dimension B of the angled joint you use is different from that dimension B, adjust the L dimension of the equalizer pipes 1 and 2 accordingly.

Table 14

Equalizer pipe		L
Pipe 1 (L mm)	Pipe 2 (L mm)	
78	60	

Table 15

Joint (angle of 90°)	B (mm)
B (mm)	
17	

5. AFTER CONNECTION OF THE PIPING

Connection piping between the outdoor and indoor unit

All piping must be executed according to instructions in the installation manual of the outdoor unit and an air tight test must be performed after complete installation of the piping.

Insulation of joints

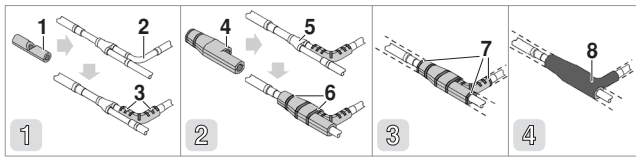

Step 1: Fit the insulation (1) around the reducer (2) and keep it in place with tape (8) (3).

Step 2: Fit the insulation (4) around the joint (5) and keep it in place with tape (8) (6) without leaving a gap between the two insulated parts.

Step 3: Seal the seam between the insulation and the field piping insulation (---) with tape (8) (7).

Step 4: Cover the insulated parts completely with tape (8) without leaving any gaps (8).



- All required tape is field supply.
- In case of indoor installation, make sure that the tape is of the fireproof type in order to comply with local regulations.

IN CASE OF LOWER FRONT PIPING

1. EXTERIOR

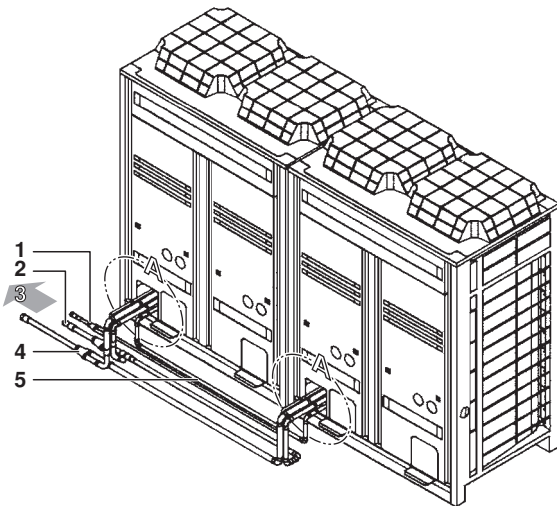

- | | | | |
|---|-----------------|---|-------------------|
| 1 | Liquid joint | 3 | To indoor unit |
| 2 | HP/LP gas joint | 4 | Suction gas joint |
| | | 5 | Equalizer pipe |

2. DIMENSIONS FOR INSTALLATION

Dimensions for standard installation

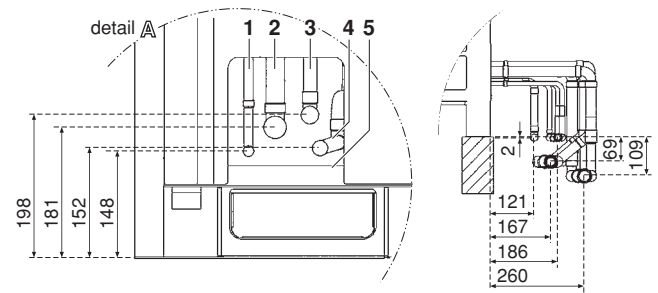

- | | |
|---|------------------|
| 1 | Liquid pipe |
| 2 | Suction gas pipe |
| 3 | HP/LP gas pipe |
| 4 | Equalizer pipe |
| 5 | Bottom frame |



NOTE When the dimensions exceed these of the standard installation, extend the pipes between the outdoor unit and the joint accordingly (field supply).

3. INSTALLATION OF SUCTION GAS AND HP/LP GAS PIPES

Cutting the field supplied suction and HP/LP gas pipes

Use the following tables for standard installation (refer to "Dimensions for installation" on page 6).

If the dimensions exceed these of the standard installation, extend the L dimension of the suction gas pipes 1~4 and HP/LP gas pipes 1~5 accordingly.

■ For suction gas pipes only

For L dimension of suction gas pipes 1~4 dimension B of the field supplied angled joint as in table 17 on page 6 has been taken into account. If dimension B of the angled joint you use is different from that dimension B, adjust the L dimension of suction gas pipes 1~4 accordingly.

Table 16

Outdoor unit	Pipe 1 L (mm)	Pipe 2 L (mm)	Pipe 3 L (mm)	Pipe 4 L (mm)	L
18 Hp	168	133	102	244	
20+22 Hp	150	133	168	244	
24 Hp	150	115	168	232	
26 Hp	150	133	168	244	
28~32 Hp	150	115	168	232	

Table 17

Outdoor unit	Joint (angle of 90°) (field supply)		B
	Joint 1 B (mm)	Joint 2 B (mm)	
18 Hp	23	23	
20+22 Hp	29	23	
24 Hp	29	29	
26 Hp	29	23	
28~32 Hp	29	29	

■ **For HP/LP gas pipes only**

For L dimension of HP/LP gas pipes 1~5 dimension B of the field supplied angled joint as in table 19 on page 7 has been taken into account. If dimension B of the angled joint you use is different from that dimension B, adjust the L dimension of HP/LP gas pipes 1~5 accordingly.

Table 18

Outdoor unit	Pipe 1 L (mm)	Pipe 2 L (mm)	Pipe 3 L (mm)	Pipe 4 L (mm)	Pipe 5 L (mm)
18~24 Hp	188	158	73	233	64
26+28 Hp	169	158	97	233	64
30+32 Hp	169	139	97	221	52

Table 19

Joint (angle of 90°) (field supply)		
Outdoor unit	Joint 3 B (mm)	Joint 4 B (mm)
18~24 Hp	17	17
26+28 Hp	23	17
30+32 Hp	23	23

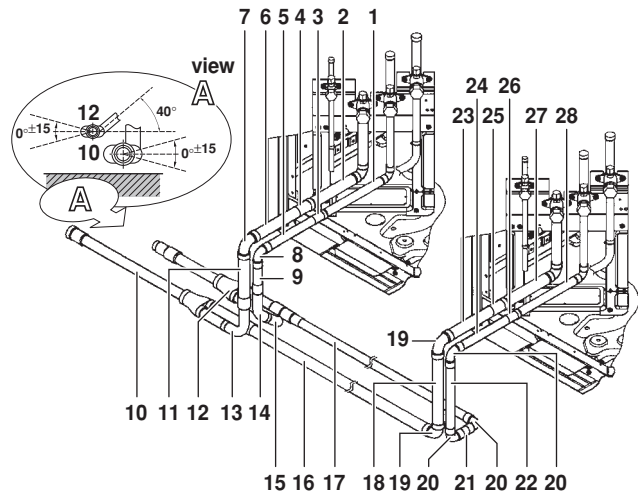
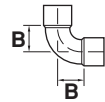

- 1 HP/LP gas accessory pipe (1) supplied with the outdoor unit
- 2 Suction gas accessory pipe (1) supplied with the outdoor unit
- 3 HP/LP gas inch-mm reducer (a) refer to table 7 on page 3
- 4 Suction gas inch-mm reducer (a) refer to table 7 on page 3
- 5 HP/LP gas pipe (1) (field supply) refer to table 18 on page 7
- 6 Suction gas pipe (1) (field supply) refer to table 16 on page 6
- 7 Joint (1) (angle of 90°) (field supply) refer to table 17 on page 6
- 8 Joint (3) (angle of 90°) (field supply) refer to table 19 on page 7
- 9 HP/LP gas pipe (3) (field supply) refer to table 18 on page 7
- 10 Suction gas joint
- 11 Suction gas pipe (3) (field supply) refer to table 16 on page 6
- 12 HP/LP gas joint
- 13 Suction gas reducer (1)
- 14 HP/LP gas reducer (2)
- 15 HP/LP gas reducer (1)
- 16 Suction gas pipe (field supply) (select the pipe length on site)
- 17 HP/LP gas pipe (field supply) (select the pipe length on site)
- 18 Suction gas pipe (4) (field supply) refer to table 16 on page 6
- 19 Joint (2) (angle of 90°) (field supply) refer to table 17 on page 6
- 20 Joint (4) (angle of 90°) (field supply) refer to table 19 on page 7
- 21 HP/LP gas pipe (5) (field supply) refer to table 18 on page 7
- 22 HP/LP gas pipe (4) (field supply) refer to table 18 on page 7
- 23 Suction gas pipe (2) (field supply) refer to table 16 on page 6
- 24 HP/LP gas pipe (2) (field supply) refer to table 18 on page 7
- 25 Suction gas inch-mm reducer (b) refer to table 9 on page 3
- 26 HP/LP gas inch-mm reducer (b) refer to table 9 on page 3
- 27 Suction gas accessory pipe (2) supplied with the outdoor unit
- 28 HP/LP gas accessory pipe (2) supplied with the outdoor unit

Cutting suction gas reducer (1) and HP/LP gas reducer (2)

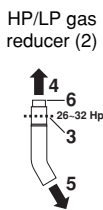
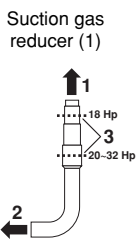

- 1 Connection to suction gas pipe 1 (field supply)
- 2 Connection to suction gas joint
- 3 Cutting position
- 4 Connection to HP/LP gas pipe 1 (field supply)
- 5 Connection to HP/LP gas reducer (1)
- 6 No cutting for 18~24 Hp

Connection piping

- Connect the suction gas and HP/LP gas pipes as shown in the figure below. Before connecting the pipes, first connect the suction gas joint and the suction gas reducer (1), the HP/LP joint and the HP/LP reducer (1) and (2).
- See "Dimensions for installation" on page 6 for the location (height) of the joint.
- Refer to the installation manual delivered with the outdoor unit for cautions on brazing pipes.
- Keep the joint in a horizontal position (see view A).
- Connect the HP/LP gas reducer (1) by tilting it $\pm 40^\circ$ and connect the HP/LP gas reducer (2), see view A in the figure below.
- Refer to "Pipe size selection and cutting position of the joint" on page 3 for the cutting requirements of both joint and reducer.

4. INSTALLATION OF LIQUID PIPES AND EQUALIZER PIPES

Cutting the field supplied equalizer pipes

Use the following tables for standard installation (refer to "Dimensions for installation" on page 6).

If dimensions differ from standard installation, adjust the L dimension of the equalizer pipes 1 and 2 accordingly.

For L dimension of equalizer pipes 1 and 2, dimension B of the field supplied angled joint as in table 15 on page 5 has been taken into account. If dimension B of the angled joint you use is different from that dimension B, adjust the L dimension of the equalizer pipes 1 and 2 accordingly.

Table 20

Equalizer pipe		L
Pipe 1 (L mm)	Pipe 2 (L mm)	
60	120	

Cutting liquid reducer (1)

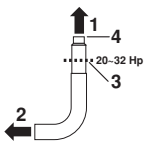

- 1 Connection to liquid pipe (field supply)
- 2 Connection to liquid joint
- 3 Cutting position
- 4 No cutting for 18 Hp

Connection piping

- Connect the liquid pipes and equalizer pipes as shown in the figure below. Before connecting the pipes, first connect the liquid joint and the liquid reducer (1).
- Refer to "Dimensions for installation" on page 6.
- Keep the joint in a horizontal position as shown in view A in the figure below
- Connect the liquid reducer (1) in an angle of $\pm 90^\circ$ and bend the field supplied liquid pipe up to the stop valve as shown in the figure.
- Refer to the installation manual delivered with the outdoor unit for cautions on brazing pipes.
- Refer to "Pipe size selection and cutting position of the joint" on page 3 for the cutting requirements for both joint and reducer.

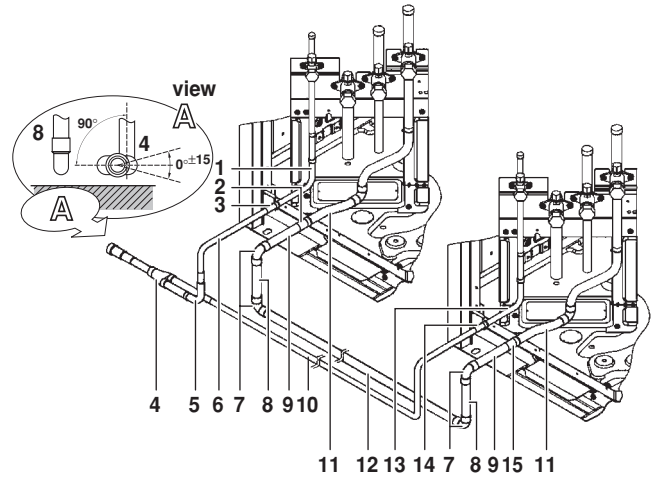

- 1 Liquid accessory pipe (1) supplied with the outdoor unit
- 2 Equalizer inch-mm reducer (a) refer to table 7 on page 3
- 3 Liquid inch-mm reducer (a) refer to table 7 on page 3
- 4 Liquid joint
- 5 Liquid reducer (1)
- 6 Liquid pipe (1) (field supply) (select the pipe length on site)
- 7 Joint (angle of 90°) (field supply) refer to table 15 on page 5
- 8 Equalizer pipe (2) (field supply) refer to table 20 on page 8
- 9 Equalizer pipe (1) (field supply) refer to table 20 on page 8
- 10 Liquid pipe (field supply) (select the pipe length on site)
- 11 Equalizer accessory pipe (1) supplied with the outdoor unit
- 12 Equalizer pipe (field supply) (select the pipe length on site)
- 13 Liquid accessory pipe (2) supplied with the outdoor unit
- 14 Liquid inch-mm reducer (b) refer to table 9 on page 3
- 15 Equalizer inch-mm reducer (b) refer to table 9 on page 3

5. AFTER CONNECTION OF THE PIPING

Connection piping between the outdoor and indoor unit

All piping must be executed according to instructions in the installation manual of the outdoor unit and an air tight test must be performed after complete installation of the piping.

Insulation of joints

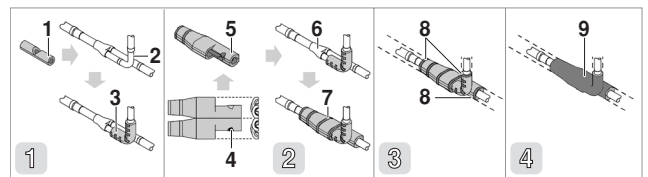

Step 1: Fit the insulation (1) around the reducer (2) and keep it in place with tape (3).

Step 2: Cut the insulation (5) along the slit (4). Fit the insulation around the joint (6) and keep it in place with tape (7) without leaving a gap between the two insulated parts.

Step 3: Seal the seam between the insulation and the field piping insulation (---) with tape (8).

Step 4: Cover the insulated parts completely with tape (9) without leaving any gaps (9).



- All required tape is field supply.
- In case of indoor installation, make sure that the tape is of the fireproof type in order to comply with local regulations.

IN CASE OF BOTTOM PIPING

1. EXTERIOR



Be sure to foresee enough space for brazing and piping work under the unit.

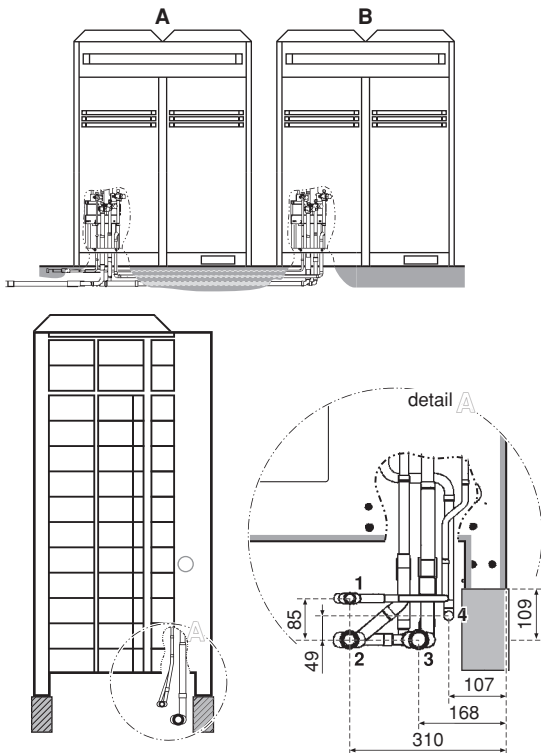

- 1 Liquid pipe
- 2 HP/LP gas pipe
- 3 Suction gas pipe
- 4 Equalizer pipe

2. INSTALLATION OF SUCTION GAS AND HP/LP GAS PIPES

Cutting the field supplied gas pipes

For suction gas pipes only

For L dimension of suction gas pipe 1 and 2, dimension B of the field supplied angled joint as in table 11 on page 4 has been taken into account. If dimension B of the angled joint you use is different from that dimension B, adjust the L dimension of suction gas pipes 1 and 2 accordingly.

Table 21

Outdoor unit	Pipe (1) L (mm)	Pipe (2) L (mm)
18 Hp	108	245
20+22 Hp	182	245
24 Hp	182	239
26 Hp	182	245
28~32 Hp	182	239

For HP/LP gas pipes only

For L dimension of HP/LP gas pipes 1~4, dimension B of the field supplied angled joint as in table 13 on page 4 has been taken into account. If dimension B of the angled joint you use is different from that dimension B, adjust the L dimension of HP/LP gas pipes 1~4 accordingly.

Table 22

Outdoor unit	Pipe (1) L (mm)	Pipe (2) L (mm)	Pipe (3) L (mm)	Pipe (4) L (mm)
18~24 Hp	180	335	86	94
26+28 Hp	140	335	86	94
30+32 Hp	140	259	110	82

Cutting suction gas reducer (1) and (2) and HP/LP gas reducer (2)

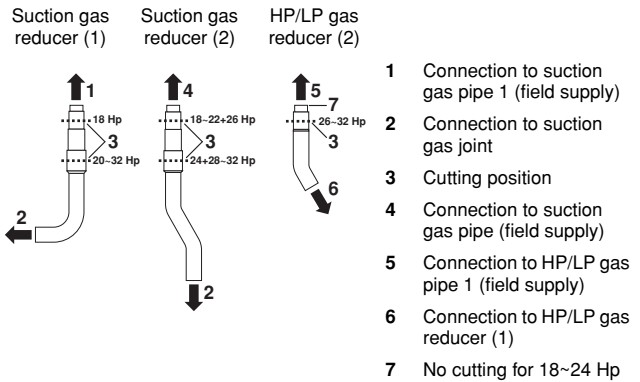

Connection piping

- Remove the knockout plate on the bottom frame. Refer to the installation manual delivered with the outdoor unit.
- Connect the suction gas and HP/LP gas pipes as shown in the figure below. Before connecting the pipes, first connect the suction gas joint and the suction gas reducer (1), the HP/LP gas joint and the HP/LP gas reducers (1) and (2).
- Refer to the installation manual delivered with the outdoor unit for cautions on brazing pipes.
- Keep the joint in a horizontal position, see view A in the figure below.
- Connect the HP/LP gas reducer (1) by tilting it $\pm 50^\circ$ and connect the HP/LP gas reducer (2) (see view A).
- Refer to "Pipe size selection and cutting position of the joint" on page 3 for the cutting requirements of both joint and reducer.

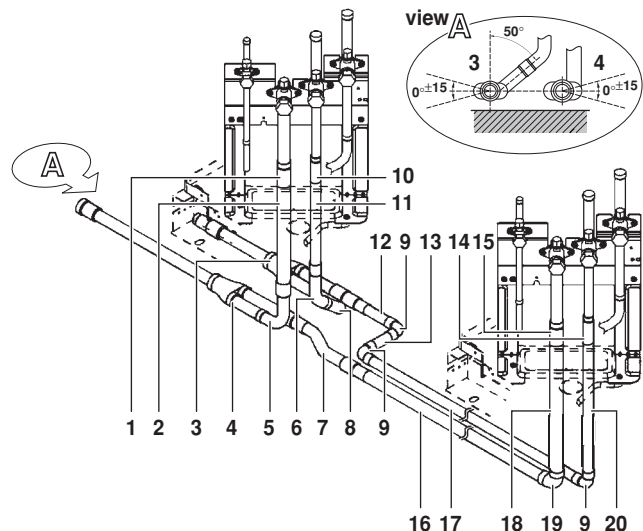

- 1 Suction gas inch-mm reducer (a) refer to table 7 on page 3
- 2 Suction gas pipe (1) (field supply) refer to table 21 on page 9
- 3 HP/LP gas joint
- 4 Suction gas joint
- 5 Suction gas reducer (1)
- 6 HP/LP gas reducer (2)
- 7 Suction gas reducer (2)
- 8 HP/LP gas reducer (1)
- 9 Joint (4) (angle of 90°) (field supply) refer to table 13 on page 4
- 10 HP/LP gas inch-mm reducer (a) refer to table 7 on page 3
- 11 HP/LP gas pipe (1) refer to table 22 on page 9
- 12 HP/LP gas pipe (3) (field supply) refer to table 22 on page 9
- 13 HP/LP gas pipe (4) (field supply) refer to table 22 on page 9
- 14 HP/LP gas inch-mm reducer (b) refer to table 9 on page 3
- 15 Suction gas inch-mm reducer (b) refer to table 9 on page 3
- 16 Suction gas pipe (field supply) (select the pipe length on site)
- 17 HP/LP gas pipe (field supply) (select the pipe length on site)
- 18 Suction gas pipe (2) refer to table 21 on page 9
- 19 Joint (2) (angle of 90°) (field supply) refer to table 11 on page 4
- 20 HP/LP gas pipe (2) refer to table 22 on page 9

3. INSTALLATION OF LIQUID PIPES AND EQUALIZER PIPES

Cutting liquid reducer (1)

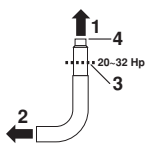

- 1 Connection to liquid pipe (field supply)
- 2 Connection to liquid joint
- 3 Cutting position
- 4 No cutting for 18 Hp

Cutting equalizer pipe (1) (field supply)

For L dimension of equalizer pipe 1, dimension B of the field supplied angled joint as in table 15 on page 5 has been taken into account. If dimension B of the angled joint you use is different from that dimension B, adjust the L dimension of equalizer pipe 1 accordingly.

Table 23

Equalizer pipe Pipe 1 (L mm)		
18-32 Hp	180	L

Connection piping

- Remove the knockout plate on the bottom frame. Refer to the installation manual delivered with the outdoor unit.
- Connect the liquid pipes and equalizer pipes as shown in the figure below.
Before connecting the pipes, first connect the liquid joint and the liquid reducer (1).
- Keep the joint in a horizontal position, see view A in the figure below.
- Bend the field supplied liquid pipe up to the stop valve as shown in the figure below.
- Refer to the installation manual delivered with the outdoor unit for cautions on brazing pipes.
- Refer to "Pipe size selection and cutting position of the joint" on page 3 for the cutting requirements of both joint and reducer.

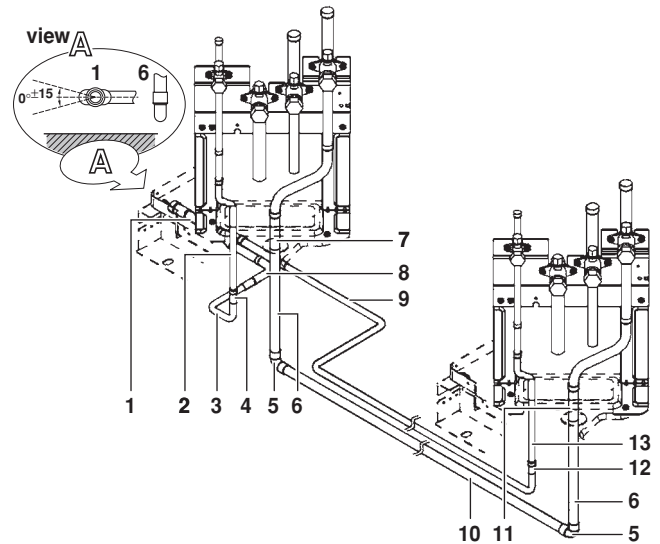

- 1 Liquid joint
- 2 Liquid accessory pipe (1) supplied with the outdoor unit
- 3 Liquid pipe (1) (field supply) (select the pipe length on site)
- 4 Liquid inch-mm reducer (a) refer to table 7 on page 3
- 5 Joint (angle of 90°) (field supply) refer to table 15 on page 5
- 6 Equalizer pipe (1) refer to table 23 on page 10
- 7 Equalizer inch-mm reducer (a) refer to table 7 on page 3
- 8 Liquid reducer (1)
- 9 Liquid pipe (2) (field supply) (select the pipe length on site)
- 10 Equalizer pipe (field supply)(select the pipe length on site)
- 11 Equalizer inch-mm reducer (b) refer to table 9 on page 3
- 12 Liquid inch-mm reducer (b) refer to table 9 on page 3
- 13 Liquid accessory pipe (2) supplied with the outdoor unit

4. AFTER CONNECTION OF THE PIPING

Connection piping between the outdoor and indoor unit

All piping must be executed according to instructions in the installation manual of the outdoor unit and an air tight test must be performed after complete installation of the piping.

Insulation of joints

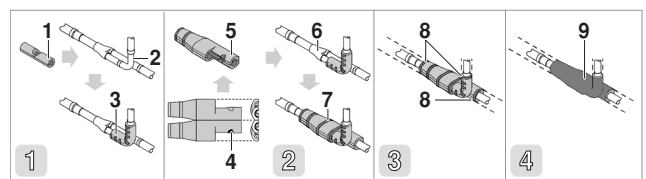

Step 1: Fit the insulation (1) around the reducer (2) and keep it in place with tape (3).

Step 2: Cut the insulation (5) along the slit (4). Fit the insulation around the joint (6) and keep it in place with tape (7) without leaving a gap between the two insulated parts.

Step 3: Seal the seam between the insulation and the field piping insulation (---) with tape (8).

Step 4: Cover the insulated parts completely with tape (9) without leaving any gaps (9).



- All required tape is field supply.
- In case of indoor installation, make sure that the tape is of the fireproof type in order to comply with local regulations.

FOR BHFQM23P1357



Refer to the installation manual of the outdoor unit for selection and restriction for the piping between outdoor branches. Not observing restrictions on the interconnecting piping may result in malfunctioning of the unit.

Pipe size selection and cutting position of joints.

Select the correct pipe size according with the tables below and cut the joints and reducers on the correct places with a pipe cutter.

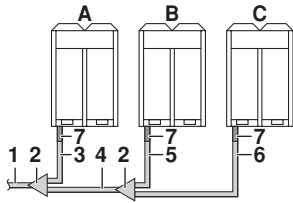

- 1 Main pipe, see table 24 on page 11
- 2 First joint (refer to "Restrictions on installing the multi connection piping kit" on page 2)
- 3 Pipe between the first joint and outdoor unit A, see table 25 on page 11
- 4 Piping inbetween connection joints
- 5 Pipe between the second joint and outdoor unit B, see table 27 on page 11
- 6 Pipe between the second joint and outdoor unit C, see table 29 on page 11
- 7 Inch-mm reducer (type depending on connection method)

Main pipe

Select the pipe size in function of the total capacity of the outdoor unit (units A+B+C).

Piping inbetween connection joints

Select the pipe size in function of the total capacity of the outdoor units to be connected upstream (units B+C).

Table 24

Total capacity outdoor units	Pipe size ⁽¹⁾		
	Suction gas	HP/LP gas	Liquid
34 Hp	Ø35x1.21 (1/2H)	Ø28x1.0 (1/2H)	Ø20x1.0 (1/2H)
36 Hp	Ø42x1.43 (1/2H)	Ø28x1.0 (1/2H)	Ø20x1.0 (1/2H)
38~48 Hp	Ø42x1.43 (1/2H)	Ø35x1.21 (1/2H)	Ø20x1.0 (1/2H)

(1) OD x minimum wall thickness (temper grade type)

- When using pipes of Ø20 or larger, make sure to use pipes with 1/2H temper grade with a wall thickness of 1.0 mm. In case there is no alternative and you use the O temper grade for pipes with Ø20, a minimal wall thickness of 1.2 mm or more is required and connections need to be brazed.

Table 25

Outdoor unit	Pipe size ⁽¹⁾			
	Suction gas	HP/LP gas	Equalizer	Liquid
34~48 Hp	Ø28x1.0 (1/2H)	Ø22x1.0 (1/2H)	Ø20x1.0 (1/2H)	Ø12x0.80 (O)

(1) OD x minimum wall thickness (temper grade type)

Table 26

Outdoor units	Inch-mm reducers (reference (a))							
	Suction gas		HP/LP gas		Equalizer		Liquid	
	(A)	(B)	(A)	(B)	(A)	(B)	(A)	(B)
34~48 Hp	(1)	(6)	(2)	(7)	(3)	(8)	(4)	(4)

(A) Inch-mm reducers for front connection and lower front connection
(B) Inch-mm reducers for bottom connection

Table 27

Outdoor unit	Pipe size ⁽¹⁾			
	Suction gas	HP/LP gas	Equalizer	Liquid
34 Hp	Ø22x1.0 (1/2H)	Ø20x1.0 (1/2H)	Ø20x1.0 (1/2H)	Ø10x0.80 (O)
36~40 Hp	Ø28x1.0 (1/2H)	Ø20x1.0 (1/2H)	Ø20x1.0 (1/2H)	Ø12x0.80 (O)
42~48 Hp	Ø28x1.0 (1/2H)	Ø22x1.0 (1/2H)	Ø20x1.0 (1/2H)	Ø12x0.80 (O)

(1) OD x minimum wall thickness (temper grade type)

Table 28

Outdoor units	Inch-mm reducers (reference (b))							
	Suction gas		HP/LP gas		Equalizer		Liquid	
	(A)	(B)	(A)	(B)	(A)	(B)	(A)	(B)
34 Hp	(2)	(9)	(3)	(8)	(3)	(8)	(5)	(5)
36~40 Hp	(1)	(6)	(3)	(8)	(3)	(8)	(4)	(4)
42~48 Hp	(1)	(6)	(2)	(7)	(3)	(8)	(4)	(4)

(A) Inch-mm reducers for front connection and lower front connection
(B) Inch-mm reducers for bottom connection

Table 29

Outdoor unit	Pipe size ⁽¹⁾			
	Suction gas	HP/LP gas	Equalizer	Liquid
34~38 Hp	Ø22x1.0 (1/2H)	Ø20x1.0 (1/2H)	Ø20x1.0 (1/2H)	Ø10x0.80 (O)
42 Hp	Ø22x1.0 (1/2H)	Ø20x1.0 (1/2H)	Ø20x1.0 (1/2H)	Ø10x0.80 (O)
40+44 Hp	Ø28x1.0 (1/2H)	Ø20x1.0 (1/2H)	Ø20x1.0 (1/2H)	Ø12x0.80 (O)
46+48 Hp	Ø28x1.0 (1/2H)	Ø22x1.0 (1/2H)	Ø20x1.0 (1/2H)	Ø12x0.80 (O)

(1) OD x minimum wall thickness (temper grade type)

Table 30

Outdoor units	Inch-mm reducers (reference (c))							
	Suction gas		HP/LP gas		Equalizer		Liquid	
	(A)	(B)	(A)	(B)	(A)	(B)	(A)	(B)
34~38 Hp	(2)	(9)	(3)	(8)	(3)	(8)	(5)	(5)
42 Hp	(2)	(9)	(3)	(8)	(3)	(8)	(5)	(5)
40+44 Hp	(1)	(6)	(3)	(8)	(3)	(8)	(4)	(4)
46+48 Hp	(1)	(6)	(2)	(7)	(3)	(8)	(4)	(4)

(A) Inch-mm reducers for front connection and lower front connection
(B) Inch-mm reducers for bottom connection

Table 31

Outdoor units	Inch-mm reducers (reference (d-f))	
	Equalizer	
34~48 Hp	(3)	

- Cut the pipe with a pipe cutter

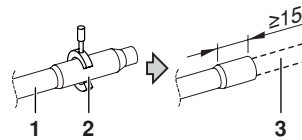

- 1 Joint or reducer
- 2 Cut in order to have a fitting depth of ≥ 15 mm
- 3 Field pipe

How to install the reducers

Suction gas pipe

- For 34 Hp, connect the suction gas reducer (5) to the suction gas joint (1) as shown in the figure below.
- For 36~48 Hp, connect the suction gas reducer (4) to the suction gas joint (1) as shown in the figure below



HP/LP gas pipe

- For 38~48 Hp, connect the suction gas reducer (5) to the HP/LP gas joint (1) as shown in the figure below.

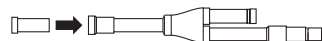

Using piping inbetween connection joints suction gas pipe

- For 40~48 Hp, connect two times the suction gas reducer (5) to the suction gas joints (1) and (2) as shown in the figure below

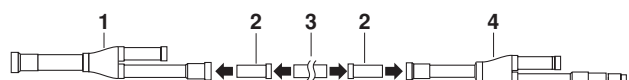

- 1 Suction gas joint (1)
- 2 Suction gas reducer (5)
- 3 Field supplied gas pipe (Ø35)
- 4 Suction gas joint (2)

IN CASE OF FRONT PIPING

1. EXTERIOR

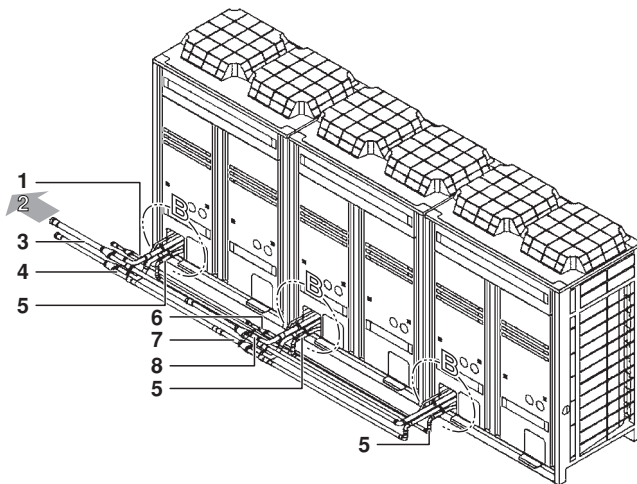

- | | |
|-------------------------|-------------------------|
| 1 liquid joint (1) | 5 Equalizer pipe |
| 2 To indoor unit | 6 liquid joint (2) |
| 3 Suction gas joint (1) | 7 HP/LP gas joint (2) |
| 4 HP/LP gas joint (1) | 8 Suction gas joint (2) |

2. DIMENSIONS FOR INSTALLATION

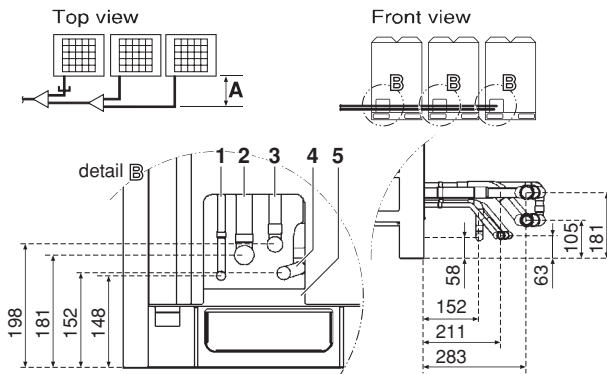

- A** 318 mm (standard)
- 1** Liquid pipe
- 2** Suction gas pipe
- 3** HP/LP gas pipe
- 4** Equalizer pipe
- 5** Bottom frame

NOTE In case dimension A exceeds 318 mm, extend the field supplied interconnection piping between the joint and the outdoor unit.

3. INSTALLATION OF SUCTION GAS AND HP/LP GAS PIPES

Cutting the field supplied gas pipes

Use the following tables in case dimension A is 318 mm (refer to "Dimensions for installation" on page 12).

If dimension A exceeds 318 mm, extend the L dimension of the gas pipes 1~3 and HP/LP gas pipes 1~4 accordingly.

■ For suction gas pipes only

For L dimension of suction gas pipes 1~3, dimension B of the field supplied angled joint as in table 33 on page 12 has been taken into account. If dimension B of the angled joint you use is different from that dimension B, adjust the L dimension of suction gas pipes 1~3 accordingly.

Table 32

Outdoor unit	Pipe 1 L (mm)	Pipe 2 L (mm)	Pipe 3 L (mm)
34 Hp	73	31	208
36+38 Hp	73	91	208
40 Hp	73	91	190
42 Hp	73	91	208
44~48 Hp	73	91	190

Table 33

Joint (angle of 90°) (field supply)	
Outdoor unit	B (mm)
34~38 Hp	23
40 Hp	29
42 Hp	23
44~48 Hp	29

■ For HP/LP gas pipes only

For L dimension of HP/LP gas pipes 1~4, dimension B of the field supplied angled joint as in table 35 on page 12 has been taken into account. If dimension B of the angled joint you use is different from that dimension B, adjust the L dimension of HP/LP gas pipes 1~4 accordingly.

Table 34

Outdoor unit	Pipe 1 L (mm)	Pipe 2 L (mm)	Pipe 3 L (mm)	Pipe 4 L (mm)
34~40 Hp	32	32	227	59
42+44 Hp	32	49	227	59
46+48 Hp	32	49	208	47

Table 35

Joint (angle of 90°) (field supply)	
Outdoor unit	B (mm)
34~44 Hp	17
46+48 Hp	23

Cutting suction gas reducer (1) and HP/LP gas reducer (2)

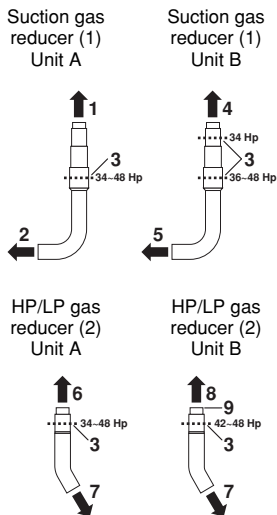

- 1 Connection to suction gas pipe 1 (field supply)
- 2 Connection to suction gas joint (1)
- 3 Cutting position
- 4 Connection to suction gas pipe 2 (field supply)
- 5 Connection to suction gas joint (2)
- 6 Connection to HP/LP gas pipe 1 (field supply)
- 7 Connection to HP/LP gas reducer (1)
- 8 Connection to HP/LP gas pipe 2 (field supply)
- 9 No cutting for 34~40 Hp

Connection piping

- Connect the suction gas and HP/LP gas pipes as shown in the figure below.
Before connecting the pipes, first connect the suction gas joint and the suction gas reducer (1), the HP/LP gas joint and the HP/LP gas reducers (1) and (2).
- See "Dimensions for installation" on page 12 for the location (height) of the joint.
- Refer to the installation manual delivered with the outdoor unit for cautions on brazing pipes.
- Keep the joint in a horizontal position, see view A in the figure below.
- Connect the HP/LP gas reducer (1) by tilting it $\pm 50^\circ$ and connect the HP/LP gas reducer (2), see view A in the figure below.
- Refer to "Pipe size selection and cutting position of joints." on page 11 for the cutting requirements.

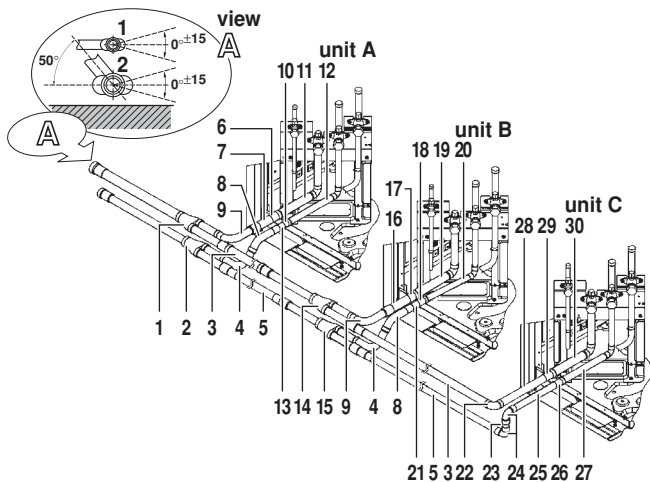

- 1 Suction gas joint (1)
- 2 HP/LP gas joint (1)
- 3 Suction gas pipe (field supply) (select the pipe length on site)
- 4 HP/LP gas reducer (1)
- 5 HP/LP gas pipe (field supply) (select the pipe length on site)
- 6 Suction gas inch-mm reducer (a) refer to table 26 on page 11
- 7 Suction gas pipe (1) (field supply) refer to table 32 on page 12
- 8 HP/LP gas reducer (2)
- 9 Suction gas reducer (1)
- 10 HP/LP gas inch-mm reducer (a) refer to table 26 on page 11
- 11 Suction gas accessory pipe (1) supplied with the outdoor unit
- 12 HP/LP gas accessory pipe (1) supplied with the outdoor unit

- 13 HP/LP gas pipe (1) (field supply) refer to table 34 on page 12
- 14 Suction gas joint (2)
- 15 HP/LP gas joint (2)
- 16 Suction gas pipe (2) (field supply) refer to table 32 on page 12
- 17 Suction gas inch-mm reducer (b) refer to table 28 on page 11
- 18 HP/LP gas inch-mm reducer (b) refer to table 28 on page 11
- 19 Suction gas accessory pipe (2) supplied with the outdoor unit
- 20 HP/LP gas accessory pipe (2) supplied with the outdoor unit
- 21 HP/LP gas pipe (2) (field supply) refer to table 34 on page 12
- 22 Joint (1) (angle of 90°) (field supply) refer to table 33 on page 12
- 23 HP/LP gas pipe (4) (field supply) refer to table 34 on page 12
- 24 Joint (2) (angle of 90°) (field supply) refer to table 35 on page 12
- 25 HP/LP gas pipe (3) (field supply) refer to table 34 on page 12
- 26 HP/LP gas inch-mm reducer (c) refer to table 30 on page 11
- 27 HP/LP gas accessory pipe (3) supplied with the outdoor unit
- 28 Suction gas pipe (3) (field supply) refer to table 32 on page 12
- 29 Suction gas inch-mm reducer (c) refer to table 30 on page 11
- 30 Suction gas accessory pipe (3) supplied with the outdoor unit

4. INSTALLATION OF LIQUID PIPES AND EQUALIZER PIPES

Cutting the field supplied equalizer pipes

Use the following tables in case dimension A is 318 mm (refer to "Dimensions for installation" on page 12).

If dimension A exceeds 318 mm, extend the L dimension of the equalizer pipes 1~3 accordingly.

For L dimension of equalizer pipes 1~3, dimension B of the field supplied angled joint as in table 37 on page 13 has been taken into account. If dimension B of the angled joint you use is different from that dimension B, adjust the L dimension of the equalizer pipes 1~3 accordingly.

Table 36

Equalizer pipe			
Pipe 1 (L mm)	Pipe 2 (L mm)	Pipe 3 (L mm)	L
60	60	35	

Table 37

Joint (angle of 90°)	
B (mm)	
17	

Cutting liquid reducer (1)

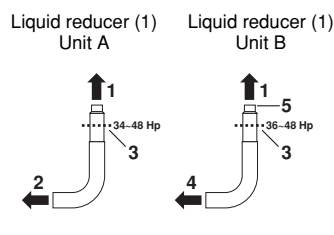

- 1 Connection to liquid pipe (field supply)
- 2 Connection to liquid joint (1)
- 3 Cutting position
- 4 Connection to liquid joint (2)
- 5 No cutting for 34 Hp

Cutting equalizer inch-mm reducer (f)

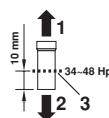

- 1 Connection to equalizer pipe (3)
- 2 Connection to equalizer joint
- 3 Cutting position

Connection piping

- Connect the liquid pipes and equalizer pipes as shown in the figure below.
Before connecting the pipes, first connect the liquid joint and the liquid reducer (1).
- Refer to "Dimensions for installation" on page 12.
- Keep the joint in a horizontal position, see view A in the figure below.
- Connect the liquid reducer (1) in an angle of 40° and bend the field supplied liquid pipe up to the stop valve as shown in the figure, see view A.
- Refer to the installation manual delivered with the outdoor unit for cautions on brazing pipes.
- Refer to "Pipe size selection and cutting position of joints." on page 11 for the cutting requirements of both joint and reducer.

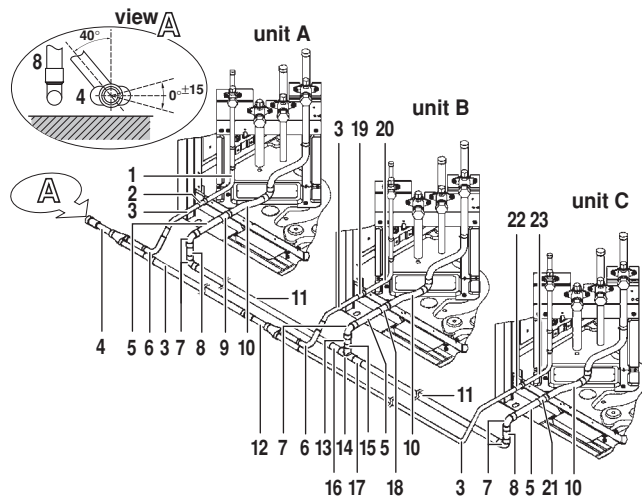

- 1 Liquid accessory pipe (1) supplied with the outdoor unit
- 2 Liquid inch-mm reducer (a) refer to table 26 on page 11
- 3 Liquid pipe (field supply) (select the pipe length on site)
- 4 Liquid joint (1)
- 5 Equalizer pipe (1) (field supply) refer to table 36 on page 13
- 6 Liquid reducer (1)
- 7 Joint (angle of 90°) (field supply) refer to table 37 on page 13
- 8 Equalizer pipe (2) (field supply) refer to table 36 on page 13
- 9 Equalizer inch-mm reducer (a) refer to table 26 on page 11
- 10 Equalizer accessory pipe (1) supplied with the outdoor unit
- 11 Equalizer pipe (field supply) (select the pipe length on site)
- 12 Liquid joint (2)
- 13 Equalizer pipe (3) (field supply) refer to table 36 on page 13
- 14 Equalizer joint
- 15 Equalizer inch-mm reducer (f) refer to table 31 on page 11 (cutting required, refer to "Cutting equalizer inch-mm reducer (f)" on page 13)
- 16 Equalizer inch-mm reducer (e) refer to table 31 on page 11
- 17 Equalizer inch-mm reducer (d) refer to table 31 on page 11
- 18 Equalizer inch-mm reducer (b) refer to table 28 on page 11
- 19 Liquid inch-mm reducer (b) refer to table 28 on page 11
- 20 Liquid accessory pipe (2) supplied with the outdoor unit
- 21 Equalizer inch-mm reducer (c) refer to table 30 on page 11
- 22 Liquid inch-mm reducer (c) refer to table 30 on page 11
- 23 Liquid accessory pipe (3) supplied with the outdoor unit

5. AFTER CONNECTION OF THE PIPING

Follow the instructions in the paragraph "After connection of the piping" on page 6.

IN CASE OF LOWER FRONT PIPING

1. EXTERIOR

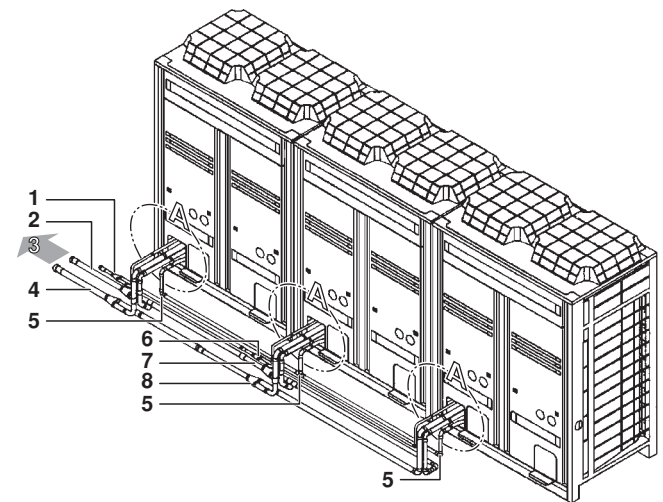

- 1 Liquid joint (1)
- 2 HP/LP gas joint (1)
- 3 To indoor unit
- 4 Suction gas joint (1)
- 5 Equalizer pipe
- 6 Liquid joint (2)
- 7 HP/LP gas joint (2)
- 8 Suction gas joint (2)

2. DIMENSIONS FOR INSTALLATION

Dimensions for standard installation

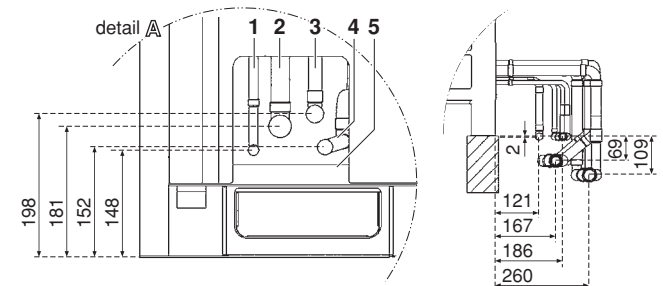

- 1 Liquid pipe
- 2 Suction gas pipe
- 3 HP/LP gas pipe
- 4 Equalizer pipe
- 5 Bottom frame

NOTE When the dimensions exceed these of the standard installation, extend the pipes between the outdoor unit and the joint accordingly (field supply).

3. INSTALLATION OF SUCTION GAS AND HP/LP GAS PIPES

Cutting the field supplied gas pipes

Use the following tables for standard installation (refer to "Dimensions for installation" on page 14).

If the dimensions exceed these of the standard installation, extend the L dimension of the suction gas pipes 1~6 and HP/LP gas pipes 1~7 accordingly.

■ For suction gas pipes only

For L dimension of suction gas pipes 1~6 dimension B of the field supplied angled joint as in table 39 on page 15 has been taken into account. If dimension B of the angled joint you use is different from that dimension B, adjust the L dimension of suction gas pipes 1~6 accordingly.

Table 38

Outdoor unit (Hp)	Pipe 1 L(mm)	Pipe 2 L(mm)	Pipe 3 L(mm)	Pipe 4 L(mm)	Pipe 5 L(mm)	Pipe 6 L(mm)	L
34	150	151	116	168	102	244	
36+38	150	133	116	168	168	244	
40	150	133	98	168	168	232	
42	150	133	116	168	168	244	
44~48	150	133	98	168	168	232	

Table 39

Joint (angle of 90°) (field supply)				L
Outdoor unit	Joint 1 B (mm)	Joint 2 B (mm)	Joint 3 B (mm)	
34 Hp	29	23	23	
36+38 Hp	29	29	23	
40 Hp	29	29	29	
42 Hp	29	29	23	
44~48 Hp	29	29	29	

■ For HP/LP gas pipes only

For L dimension of HP/LP gas pipes 1~7 dimension B of the field supplied angled joint as in table 41 on page 15 has been taken into account. If dimension B of the angled joint you use is different from that dimension B, adjust the L dimension of HP/LP gas pipes 1~7 accordingly.

Table 40

Outdoor unit (Hp)	Pipe 1 L (mm)	Pipe 2 L (mm)	Pipe 3 L (mm)	Pipe 4 L (mm)	Pipe 5 L (mm)	Pipe 6 L (mm)	Pipe 7 L (mm)	L
34~40	169	171	141	97	73	233	64	
42+44	169	152	141	97	97	233	64	
46+48	169	152	122	97	97	221	52	

Table 41

Joint (angle of 90°) (field supply)				L
Outdoor unit	Joint 4 B (mm)	Joint 5 B (mm)	Joint 6 B (mm)	
34~40 Hp	23	17	17	
42+44 Hp	23	23	17	
46+48 Hp	23	23	23	

Cutting suction gas reducer (1) and HP/LP gas reducer (2)

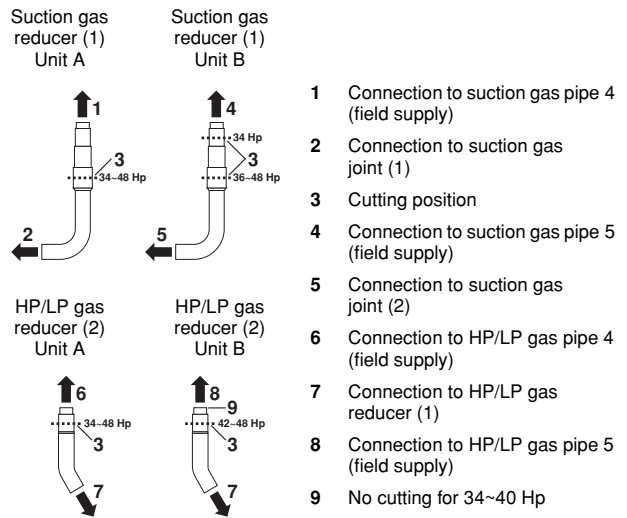

- 1 Connection to suction gas pipe 4 (field supply)
- 2 Connection to suction gas joint (1)
- 3 Cutting position
- 4 Connection to suction gas pipe 5 (field supply)
- 5 Connection to suction gas joint (2)
- 6 Connection to HP/LP gas pipe 4 (field supply)
- 7 Connection to HP/LP gas reducer (1)
- 8 Connection to HP/LP gas pipe 5 (field supply)
- 9 No cutting for 34~40 Hp

Connection piping

- Connect the suction gas and HP/LP pipes as shown in the figure below.
Before connecting the pipes, first connect the suction gas joint and the suction gas reducer (1), the HP/LP gas joint and the HP/LP gas reducer (1) and (2).
- See "Dimensions for installation" on page 14 for the location (height) of the joint.
- Refer to the installation manual delivered with the outdoor unit for cautions on brazing pipes.
- Keep the joint in a horizontal position, see view A in the figure below.
- Connect the HP/LP gas reducer (1) by tilting it $\pm 40^\circ$ and connect the HP/LP gas reducer (2), see view A in the figure below.
- Refer to "Pipe size selection and cutting position of joints." on page 11 for the cutting requirements of both joint and reducer.

4. INSTALLATION OF LIQUID PIPES AND EQUALIZER PIPES

Cutting the field supplied equalizer pipes

Use the following tables for standard installation (refer to "Dimensions for installation" on page 14).

If dimensions differ from standard installation, adjust the L dimension of the equalizer pipes 1~3 accordingly.

For L dimension of equalizer pipes 1~3, dimension B of the field supplied angled joint as in table 37 on page 13 has been taken into account. If dimension B of the angled joint you use is different from that dimension B, adjust the L dimension of the equalizer pipes 1~3 accordingly.

Table 42

Equalizer pipe			L
Pipe 1 (L mm)	Pipe 2 (L mm)	Pipe 3 (L mm)	
30	120	85	

Cutting liquid reducer (1)

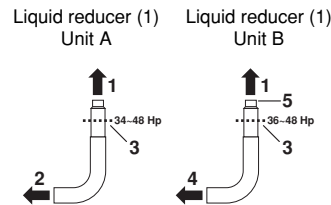

- 1 Connection to liquid pipe (field supply)
- 2 Connection to liquid joint (1)
- 3 Cutting position
- 4 Connection to liquid joint (2)
- 5 No cutting for 34 Hp

Connection piping

- Connect the liquid pipes and equalizer pipes as shown in the figure below.
Before connecting the pipes, first connect the liquid joint and the liquid reducer (1).
- Refer to "Dimensions for installation" on page 14.
- Keep the joint in a horizontal position as shown in view A in the figure below
- Connect the liquid reducer (1) in an angle of $\pm 90^\circ$ and bend the field supplied liquid pipe up to the stop valve as shown in the figure, see view A.
- Refer to the installation manual delivered with the outdoor unit for cautions on brazing pipes.
- Refer to "Pipe size selection and cutting position of joints." on page 11 for the cutting requirements of both joint and reducer.

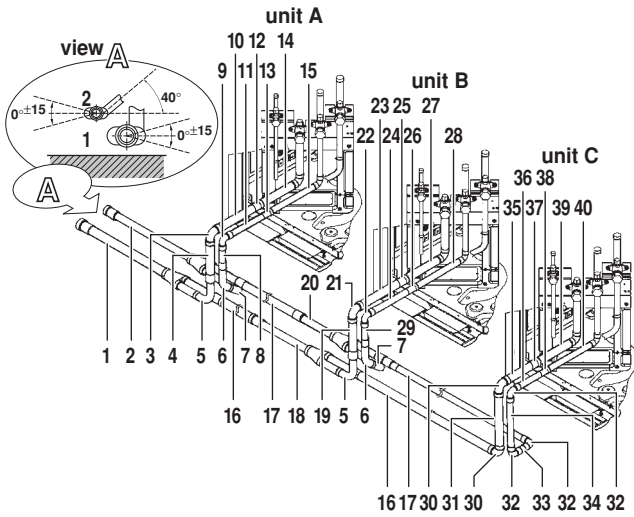

- 1 Suction gas joint (1)
- 2 HP/LP gas joint (1)
- 3 Joint 1 (angle of 90°) (field supply) refer to table 39 on page 15
- 4 Suction gas pipe (4) (field supply) refer to table 38 on page 15
- 5 Suction gas reducer (1)
- 6 HP/LP gas reducer (2)
- 7 HP/LP gas reducer (1)
- 8 HP/LP gas pipe (4) (field supply) refer to table 40 on page 15
- 9 Joint (4) (angle of 90°) (field supply) refer to table 41 on page 15
- 10 Suction gas pipe (1) (field supply) refer to table 38 on page 15
- 11 HP/LP gas pipe (1) (field supply) refer to table 40 on page 15
- 12 Suction gas inch-mm reducer (a) refer to table 26 on page 11
- 13 HP/LP gas inch-mm reducer (a) refer to table 26 on page 11
- 14 Suction gas accessory pipe (1) supplied with the outdoor unit
- 15 HP/LP gas accessory pipe (1) supplied with the outdoor unit
- 16 Suction gas pipe (field supply) (select the pipe length on site)
- 17 HP/LP gas pipe (field supply) (select the pipe length on site)
- 18 Suction gas joint (2)
- 19 Suction gas pipe (5) (field supply) refer to table 38 on page 15
- 20 HP/LP gas joint (2)
- 21 Joint (2) (angle of 90°) (field supply) refer to table 39 on page 15
- 22 Joint (5) (angle of 90°) (field supply) refer to table 41 on page 15
- 23 Suction gas pipe (2) (field supply) refer to table 38 on page 15
- 24 HP/LP gas pipe (2) (field supply) refer to table 40 on page 15
- 25 Suction gas inch-mm reducer (b) refer to table 28 on page 11
- 26 HP/LP gas inch-mm reducer (b) refer to table 28 on page 11
- 27 Suction gas accessory pipe (2) supplied with the outdoor unit
- 28 HP/LP gas accessory pipe (2) supplied with the outdoor unit
- 29 HP/LP gas pipe (5) (field supply) refer to table 40 on page 15
- 30 Joint (3) (angle of 90°) (field supply) refer to table 39 on page 15
- 31 Suction gas pipe (6) (field supply) refer to table 38 on page 15
- 32 Joint (6) (angle of 90°) (field supply) refer to table 41 on page 15
- 33 HP/LP gas pipe (7) (field supply) refer to table 40 on page 15
- 34 HP/LP gas pipe (6) (field supply) refer to table 40 on page 15
- 35 Suction gas pipe (3) (field supply) refer to table 38 on page 15
- 36 HP/LP gas pipe (3) (field supply) refer to table 40 on page 15
- 37 Suction gas inch-mm reducer (c) refer to table 30 on page 11
- 38 HP/LP gas inch-mm reducer (c) refer to table 30 on page 11
- 39 Suction gas accessory pipe (3) supplied with the outdoor unit
- 40 HP/LP gas accessory pipe (3) supplied with the outdoor unit

IN CASE OF BOTTOM PIPING

1. EXTERIOR



Be sure to foresee enough space for brazing and piping work under the unit.

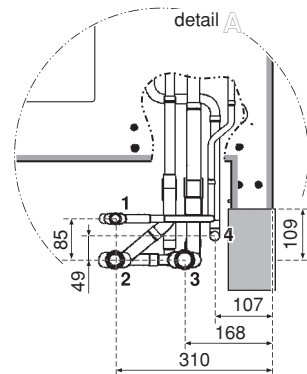
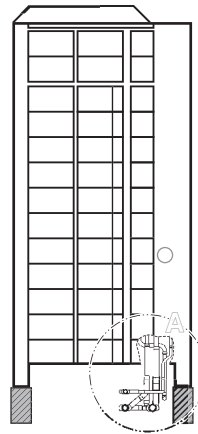
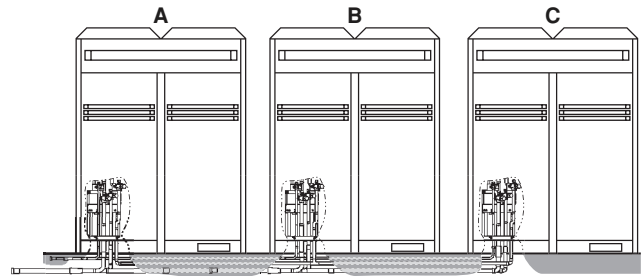

- 1 Liquid pipe
- 2 HP/LP gas pipe
- 3 Suction gas pipe
- 4 Equalizer pipe

2. INSTALLATION OF SUCTION GAS AND HP/LP GAS PIPES

Cutting the field supplied gas pipes

■ For suction gas pipes only

For L dimension of suction gas pipes 1~3, dimension B of the field supplied angled joint as in table 33 on page 12 has been taken into account. If dimension B of the angled joint you use is different from that dimension B, adjust the L dimension of suction gas pipes 1~3 accordingly.

Table 43

Outdoor unit	Pipe (1) L (mm)	Pipe (2) L (mm)	Pipe (3) L (mm)
34 Hp	182	108	245
36+38 Hp	182	182	245
40 Hp	182	182	284
42 Hp	182	182	210
44+46 Hp	182	182	284
48 Hp	182	182	239

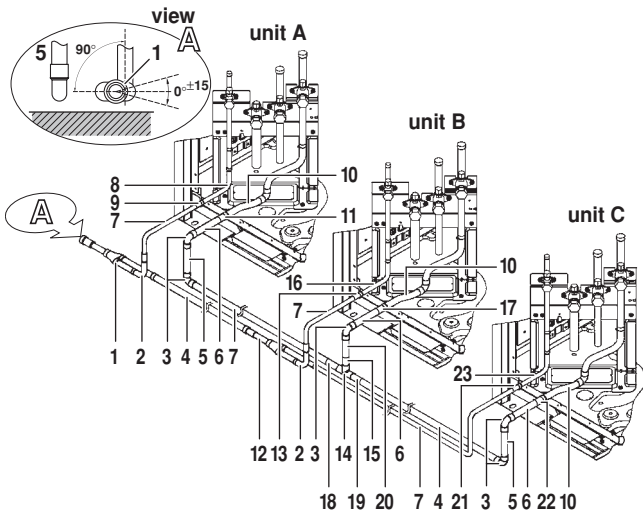

- 1 Liquid joint (1)
- 2 Liquid reducer (1)
- 3 Joint (angle of 90°) (field supply) refer to table 37 on page 13
- 4 Liquid pipe (field supply) (select the pipe length on site)
- 5 Equalizer pipe (2) (field supply) refer to table 42 on page 16
- 6 Equalizer pipe (1) (field supply) refer to table 42 on page 16
- 7 Equalizer pipe (field supply) (select the pipe length on site)
- 8 Liquid accessory pipe (1) supplied with the outdoor unit
- 9 Liquid inch-mm reducer (a) refer to table 26 on page 11
- 10 Equalizer accessory pipe (1) supplied with the outdoor unit
- 11 Equalizer inch-mm reducer (a) refer to table 26 on page 11
- 12 Liquid joint (2)
- 13 Liquid inch-mm reducer (b) refer to table 28 on page 11
- 14 Equalizer joint
- 15 Equalizer inch-mm reducer (e) refer to table 31 on page 11
- 16 Liquid accessory pipe (2) supplied with the outdoor unit
- 17 Equalizer inch-mm reducer (b) refer to table 28 on page 11
- 18 Equalizer inch-mm reducer (f) refer to table 31 on page 11
- 19 Equalizer inch-mm reducer (d) refer to table 31 on page 11
- 20 Equalizer pipe (3) (field supply) refer to table 42 on page 16
- 21 Liquid inch-mm reducer (c) refer to table 30 on page 11
- 22 Equalizer inch-mm reducer (c) refer to table 30 on page 11
- 23 Liquid accessory pipe (3) supplied with the outdoor unit

2. AFTER CONNECTION OF THE PIPING

Follow the instructions on "2. After connection of the piping" on page 8.

■ **For HP/LP gas pipes only**

For L dimension of HP/LP gas pipes 1~5, dimension B of the field supplied angled joint as in table 35 on page 12 has been taken into account. If dimension B of the angled joint you use is different from that dimension B, adjust the L dimension of HP/LP gas pipes 1~5 accordingly.

Table 44

Outdoor unit	Pipe (1) L (mm)	Pipe (2) L (mm)	Pipe (3) L (mm)	Pipe (4) L (mm)	Pipe (5) L (mm)
34~40 Hp	140	180	335	86	94
42+44 Hp	140	140	335	86	94
46+48 Hp	140	140	259	110	82

Cutting suction gas reducer (1), (2) and (3) and HP/LP gas reducer (2) and (3)

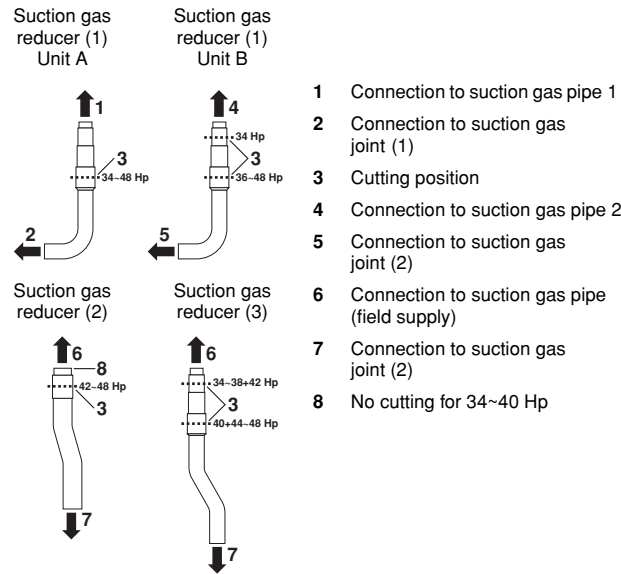

- 1 Connection to suction gas pipe 1
- 2 Connection to suction gas joint (1)
- 3 Cutting position
- 4 Connection to suction gas pipe 2
- 5 Connection to suction gas joint (2)
- 6 Connection to suction gas pipe (field supply)
- 7 Connection to suction gas joint (2)
- 8 No cutting for 34~40 Hp

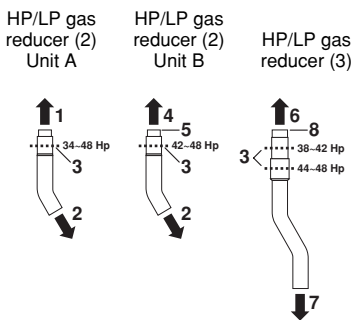

- 1 Connection to HP/LP gas pipe 1
- 2 Connection to HP/LP gas reducer (1)
- 3 Cutting position
- 4 Connection to HP/LP gas pipe 2
- 5 No cutting for 34~40 Hp
- 6 Connection to HP/LP gas pipe (field supply)
- 7 Connection to HP/LP gas joint (2)
- 8 No cutting for 34+36 Hp

Connection piping

- Remove the knockout plate on the bottom frame. Refer to the installation manual delivered with the outdoor unit.
- Connect the suction gas pipes and HP/LP gas pipes (as shown in the figure below).
Before connecting the pipes, first connect the suction gas joint and the suction gas reducer (1), the HP/LP gas joint and the HP/LP gas reducers (1) and (2).
- Refer to the installation manual delivered with the outdoor unit for cautions on brazing pipes.
- Keep the joint in a horizontal position, see view A in the figure below.
- Connect the HP/LP gas reducer (1) by tilting it $\pm 50^\circ$ and connect the HP/LP gas reducer (2) (see view A).
- Refer to "Pipe size selection and cutting position of joints." on page 11 for the cutting requirements of both joint and reducer.

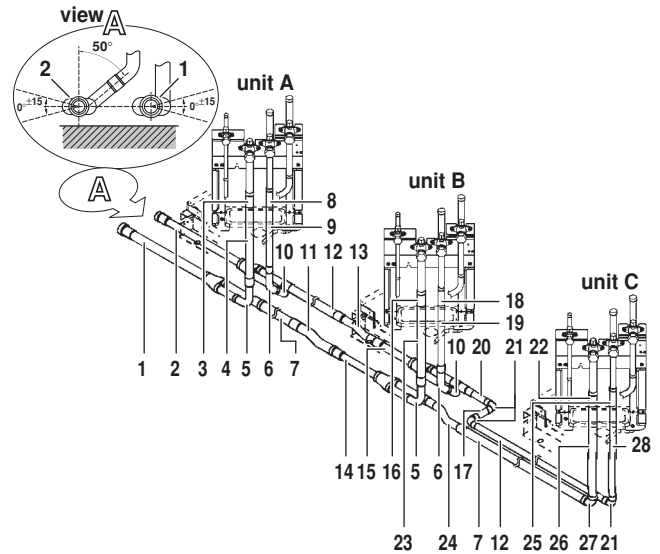

- 1 Suction gas joint (1)
- 2 HP/LP gas joint (1)
- 3 Suction gas inch-mm reducer (a) refer to table 26 on page 11
- 4 Suction gas pipe (1) (field supply) refer to table 43 on page 17
- 5 Suction gas reducer (1)
- 6 HP/LP gas reducer (2)
- 7 Suction gas pipe (field supply) (select the pipe length on site)
- 8 HP/LP gas inch-mm reducer (a) refer to table 26 on page 11
- 9 HP/LP gas pipe (1) (field supply) refer to table 44 on page 18
- 10 HP/LP gas reducer (1)
- 11 Suction gas reducer (2)
- 12 HP/LP gas pipe (field supply) (select the pipe length on site)
- 13 HP/LP gas reducer (3)
- 14 Suction gas joint (2)
- 15 HP/LP gas joint (2)
- 16 Suction gas inch-mm reducer (b) refer to table 28 on page 11
- 17 HP/LP gas pipe (5) (field supply) refer to table 44 on page 18
- 18 HP/LP gas inch-mm reducer (b) refer to table 28 on page 11
- 19 HP/LP gas pipe (2) (field supply) refer to table 44 on page 18
- 20 HP/LP gas pipe (4) (field supply) refer to table 44 on page 18
- 21 Joint (6) (angle of 90°) (field supply) refer to table 35 on page 12
- 22 Suction gas inch-mm reducer (c) refer to table 30 on page 11
- 23 Suction gas pipe (2) (field supply) refer to table 43 on page 17
- 24 Suction gas reducer (3)
- 25 HP/LP gas inch-mm reducer (c) refer to table 30 on page 11
- 26 Suction gas pipe (3) (field supply) refer to table 43 on page 17
- 27 Joint (3) (angle of 90°) (field supply) refer to table 33 on page 12
- 28 HP/LP gas pipe (3) (field supply) refer to table 44 on page 18

3. INSTALLATION OF LIQUID PIPES AND EQUALIZER PIPES

Cutting liquid reducer (1)

Liquid reducer (1) Unit A Liquid reducer (1) Unit B

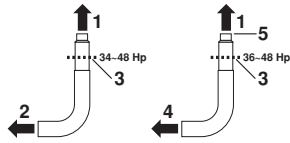

- 1 Connection to liquid pipe (1) (field supply)
- 2 Connection to liquid joint (1)
- 3 Cutting position
- 4 Connection to liquid joint (2)
- 5 No cutting for 34 Hp

Cutting equalizer pipes (field supply)

Table 45

	Equalizer pipe			L
	Pipe 1 (L mm)	Pipe 2 (L mm)	Pipe 3 (L mm)	
34~48 Hp	180	145	180	

Connection piping

- Remove the knockout plate on the bottom frame. Refer to the installation manual delivered with the outdoor unit.
- Connect the liquid pipes and equalizer pipes as shown in the figure below.
Before connecting the pipes, first connect the liquid joint and the liquid reducer (1).
- Keep the joint in a horizontal position, see view A in the figure below.
- Bend the field supplied liquid pipe up to the stop valve as shown in view A in the figure below.
- Refer to the installation manual delivered with the outdoor unit for cautions on brazing pipes for both joint and reducer.
- Refer to "Pipe size selection and cutting position of joints." on page 11 for the cutting requirements of both joint and reducer

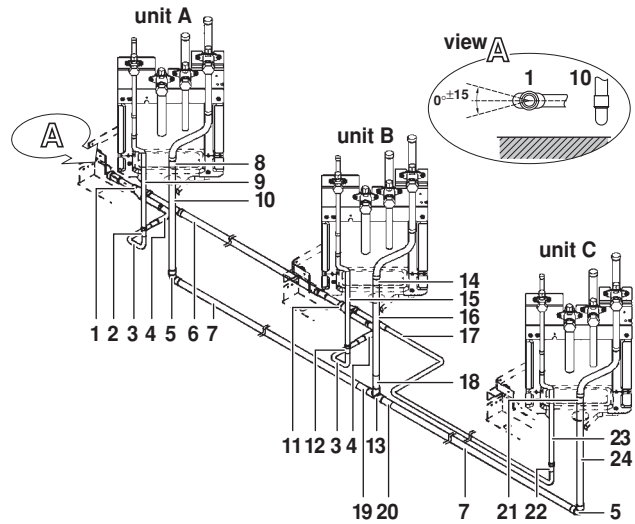

- 1 Liquid joint (1)
- 2 Liquid inch-mm reducer (a) refer to table 26 on page 11
- 3 Liquid pipe (1) (field supply) (select the pipe length on site)
- 4 Liquid reducer (1)
- 5 Joint (angle of 90°) (field supply) refer to table 37 on page 13
- 6 Liquid pipe (2) (field supply) (select the pipe length on site)
- 7 Equalizer pipe (field supply) (select the pipe length on site)
- 8 Equalizer inch-mm reducer (a) refer to table 26 on page 11
- 9 Liquid accessory pipe (1) supplied with the outdoor unit
- 10 Equalizer pipe (1) refer to table 45 on page 19
- 11 Liquid joint (2)
- 12 Liquid inch-mm reducer (b) refer to table 28 on page 11
- 13 Equalizer joint
- 14 Equalizer inch-mm reducer (b) refer to table 28 on page 11
- 15 Liquid accessory pipe (2) supplied with the outdoor unit
- 16 Equalizer pipe (2) (field supply) refer to table 45 on page 19
- 17 Liquid pipe (3) (field supply) (select the pipe length on site)
- 18 Equalizer inch-mm reducer (d) refer to table 31 on page 11
- 19 Equalizer inch-mm reducer (e) refer to table 31 on page 11
- 20 Equalizer inch-mm reducer (f) refer to table 31 on page 11
- 21 Equalizer inch-mm reducer (c) refer to table 30 on page 11
- 22 Liquid inch-mm reducer (c) refer to table 30 on page 11
- 23 Liquid accessory pipe (3) supplied with the outdoor unit
- 24 Equalizer pipe (3) (field supply) refer to table 45 on page 19

4. AFTER CONNECTION OF THE PIPING

Follow the instructions on "After connection of the piping" on page 10.

NOTES

