



INSTALLATION MANUAL

VRV[®] III-C System air conditioner

[System]

RTSYQ10PY1
RTSYQ14PY1
RTSYQ16PY1
RTSYQ20PY1

[Independent units]

RTSQ8PY1
RTSQ10PY1
RTSQ12PY1
RTSQ14PY1
RTSQ16PY1
BTSQ20PY1

Installation manual
VRV[®] III-C System air conditioner

English

Installationsanleitung
VRV[®] III-C System Klimaanlage

Deutsch

Manuel d'installation
Conditionneur d'air VRV[®] III-C System

Français

Руководство по монтажу
Кондиционер системы VRV[®] III-C

Русский

Bruksanvisning
VRV[®] III-C System Klimaanlegg

Norsk

Bruksanvisning
VRV[®] III-C System luftkonditionerare

Svenska

Instrukcja obsługi
Klimatyzator VRV[®] III-C System

Polski

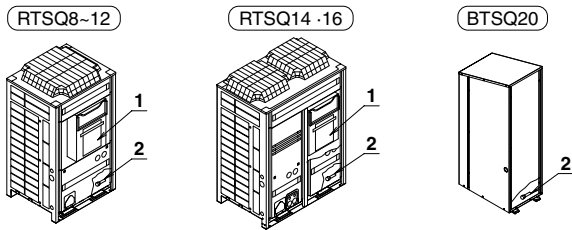

figure 1

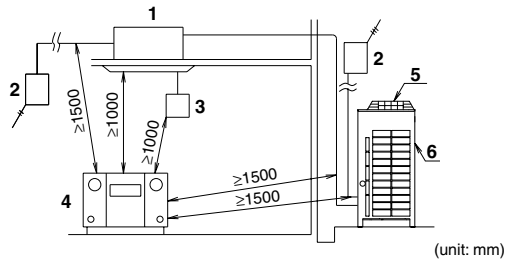

figure 3

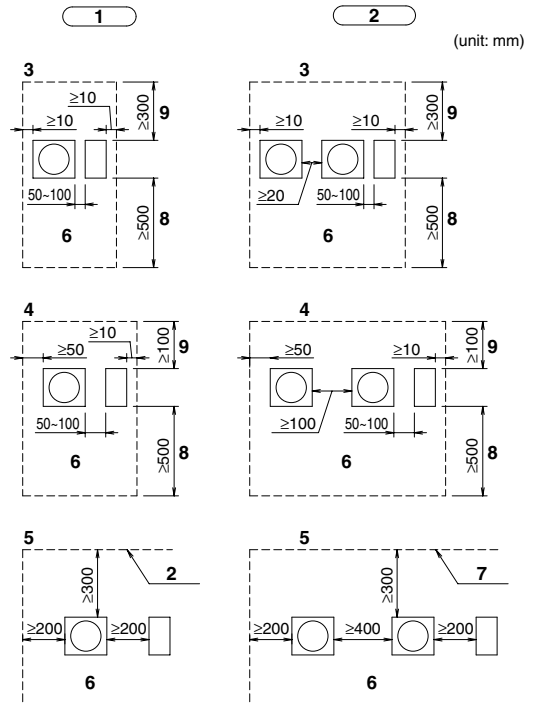

figure 2

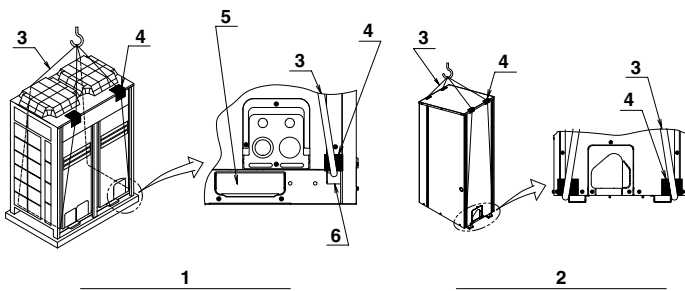

figure 4

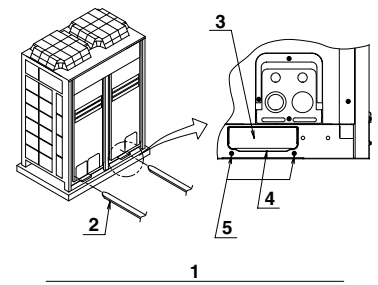

figure 5

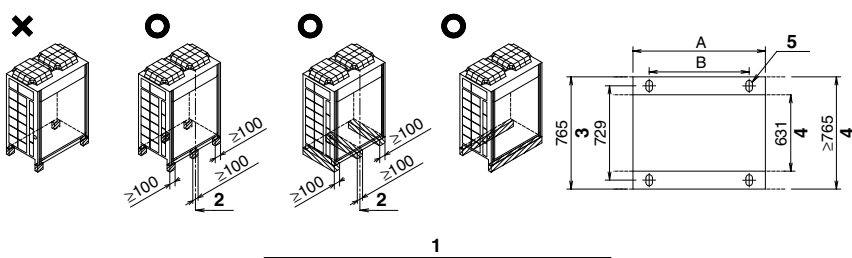

figure 6

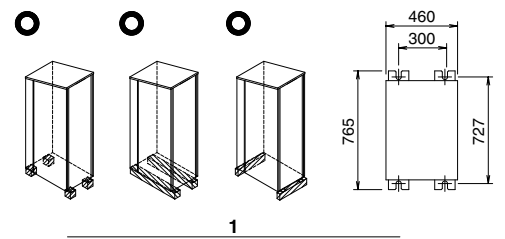

figure 7

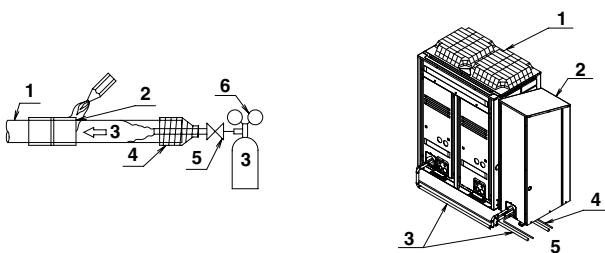

figure 8

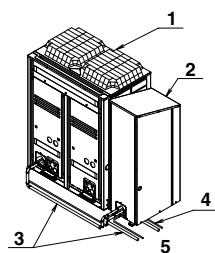

figure 9

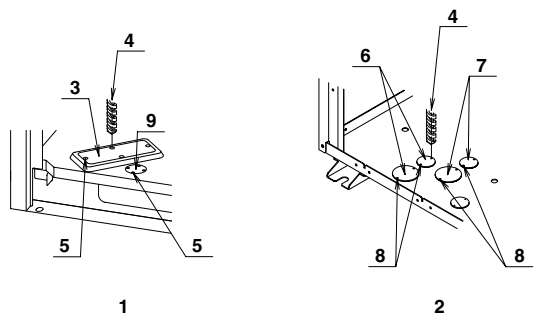

figure 10

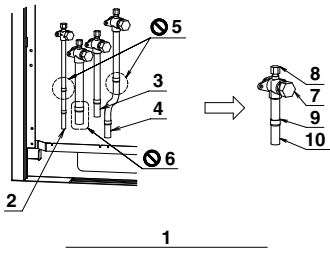

figure 11

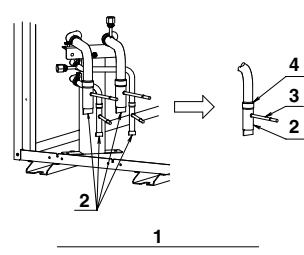

figure 12

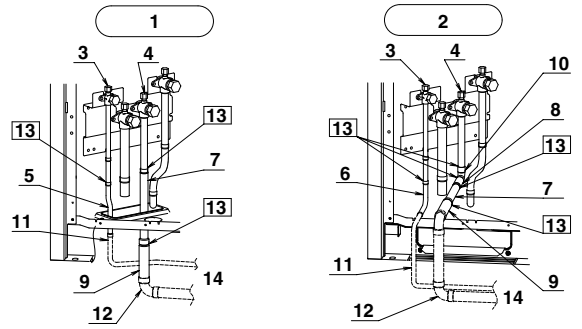

figure 13

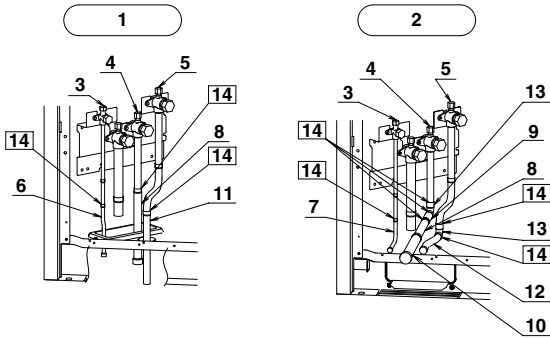

figure 14

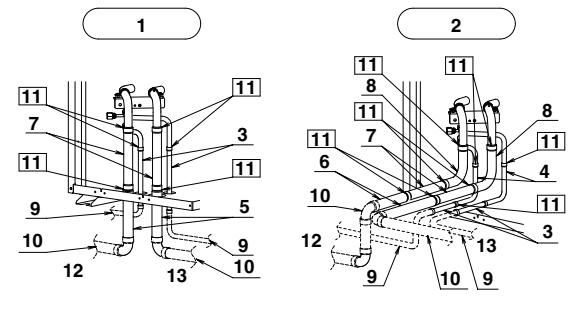

figure 15

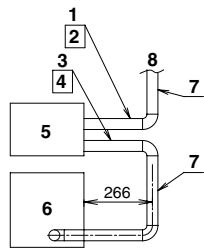

figure 16

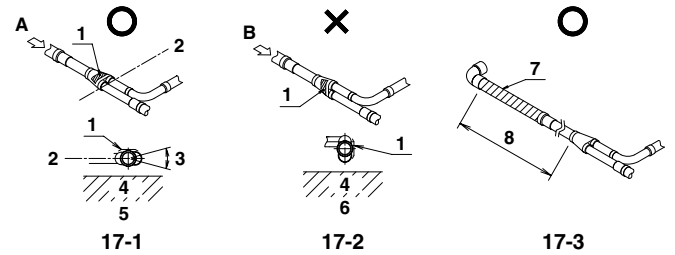

figure 17

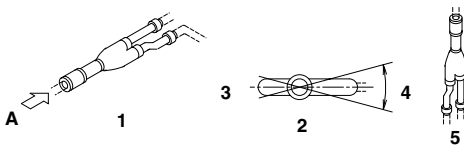

figure 18

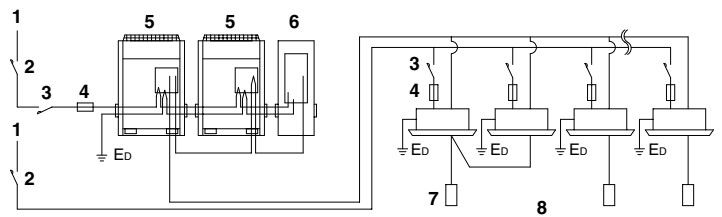

figure 19

figure 20

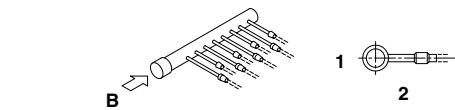

figure 21

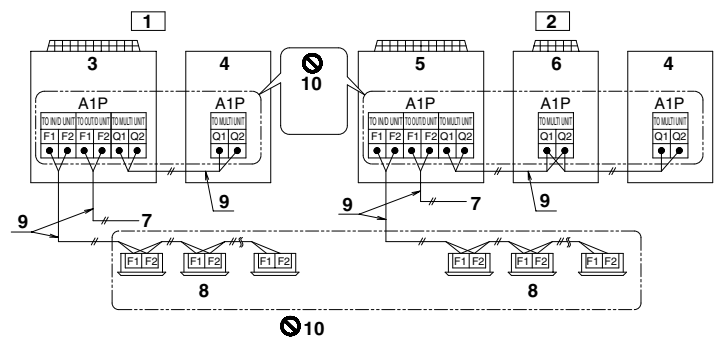

figure 22

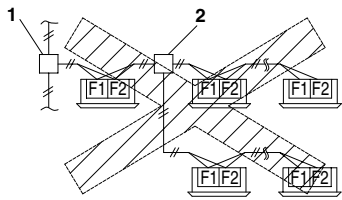

figure 23

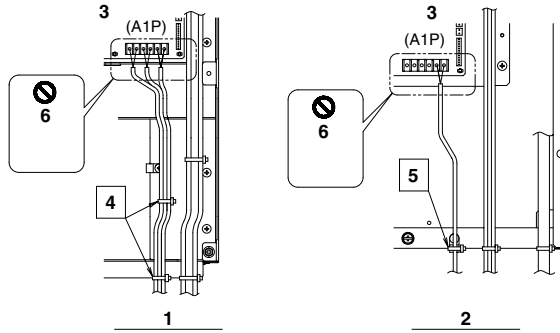

figure 24

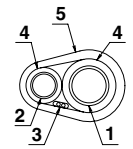

figure 25

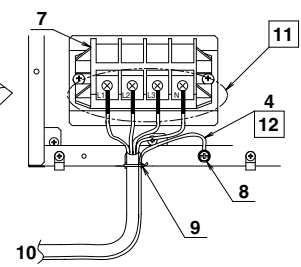
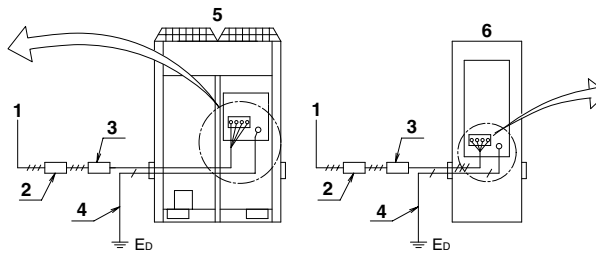
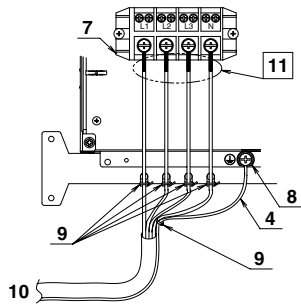

figure 26

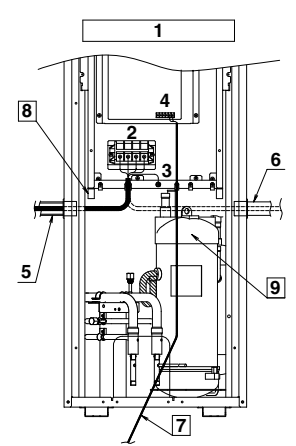
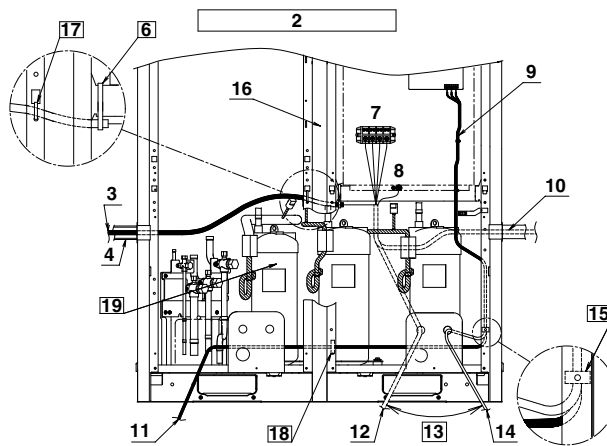
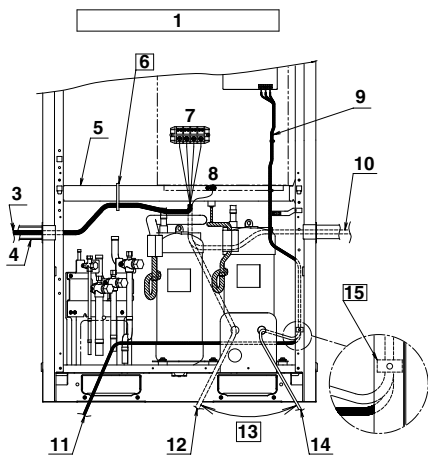

figure 27

figure 28

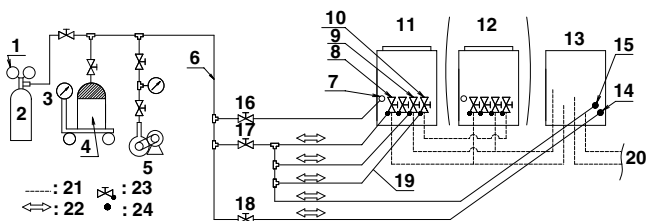

figure 29

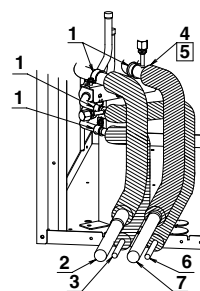

figure 30

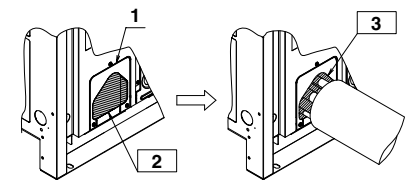

figure 31

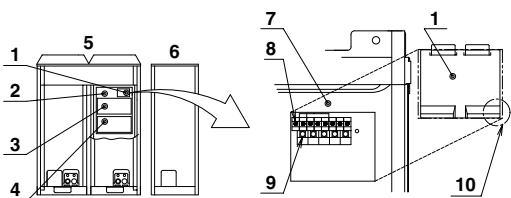

figure 32

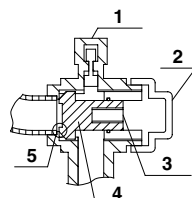

figure 33

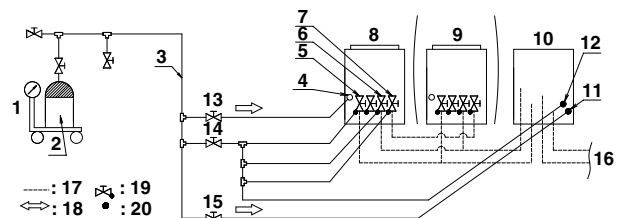

figure 34

CONTENTS

1. FIRST OF ALL	1
1-1. Safety precautions	1
1-2. Special notice of product.....	2
1-3. Disposal requirements	2
2. INTRODUCTION.....	2
2-1. About product.....	2
2-2. Technical and Electrical specifications	3
2-3. Main components.....	3
2-4. Combination.....	3
2-5. Standard supplied accessories	3
2-6. Option accessory	3
3. SELECTION OF LOCATION	4
4. INSPECTING AND HANDLING THE UNIT	4
5. PLACING THE UNIT.....	5
6. REFRIGERANT PIPING	5
6-1. Selection of piping material and Refrigerant branching kit.....	5
6-2. Protection against contamination when installing pipes.....	5
6-3. Pipe connection	5
6-4. Connecting the refrigerant piping.....	6
6-5. Example of connection.....	9
7. FIELD WIRING	12
7-1. Power circuit, safety device and cable requirements.....	12
7-2. Wiring Connection Example for Whole System	12
7-3. Leading wire Procedure	13
7-4. Transmission Wiring Connection Procedure.....	13
7-5. Power Wiring Connection Procedure	13
7-6. Procedure for Wiring Inside Units	14
8. TESTS AND INSULATION WORK	14
8-1. Air tight test and vacuum drying.....	14
8-2. Pipe insulation.....	15
8-3. Checking of device and installation conditions	15
9. ADDITIONAL REFRIGERANT CHARGE AND CHECK OPERATION	16
9-1. Before working	16
9-2. Procedure of Additional Refrigerant charging.....	18
9-3. Procedure of check operation	20
10. ONSITE SETTINGS.....	20
11. TEST RUN	21
11-1. Before test run.....	21
11-2. Test Run.....	21
11-3. Checks After Test Run	21
12. CAUTION FOR REFRIGERANT LEAKS.....	21

1. FIRST OF ALL

- This document is an installation manual for the Daikin RTSYQ-P Series VRV Inverter. Before installing the unit, read this manual thoroughly, and following the instructions contained in it.
- After installation, do a test run to make sure the unit runs properly, and then explain how to operate and take care of the unit to the customer, using the operation manual.
- Lastly, make sure the customer keeps this manual, along with the operation manual, in a safe place.

1-1 Safety precautions

- Please read these "Safety precautions" carefully before installing air conditioning unit and be sure to install it correctly.
- After completing installation, conduct a trial operation to check for faults and explain to the customer how to operate the air conditioner and take care of it with the aid of the operation manual. Ask the customer to store the installation manual along with the operation manual for future reference.

Meaning of WARNING and CAUTION notices

Warning Failure to follow these instructions properly may result in personal injury or loss of life.

Caution Failure to observe these instructions properly may result in property damage or personal injury, which may be serious depending on the circumstances.

Warning

- Ask your dealer or qualified personnel to carry out installation work. Do not attempt to install the air conditioner yourself. Improper installation may result in water leakage, electric shocks or fire.
- Install the air conditioner in accordance with the instructions in this installation manual. Improper installation may result in water leakage, electric shocks or fire.
- When installing the unit in a small room, take measures against to keep refrigerant concentration from exceeding allowable safety limits in the event of refrigerant leakage. Contact the place of purchase for more information. Excessive refrigerant in a closed ambient can lead to oxygen deficiency.
- Be sure to use only the specified accessories and parts for installation work. Failure to use the specified parts may result in the unit falling, water leakage, electric shocks or fire.
- Install the air conditioner on a foundation strong enough to withstand the weight of the unit. A foundation of insufficient strength may result in the equipment falling and causing injury.
- Carry out the specified installation work after taking into account strong winds, typhoons or earthquakes. Failure to do so during installation work may result in the unit falling and causing accidents.
- Make sure that a separate power supply circuit is provided for this unit and that all electrical work is carried out by qualified personnel according to local and national regulations and this installation manual. An insufficient power supply capacity or improper electrical construction may lead to electric shocks or fire.
- Be sure to earth the air conditioner. Do not earth the unit to a utility pipe, lightning conductor or telephone earth lead. Imperfect earthing may result in electric shocks or fire. A high surge current from lightning or other sources may cause damage to the air conditioner.
- Be sure to install an earth leakage breaker. Failure to install an earth leakage breaker may result in electric shocks or fire.
- Be sure to switch off the unit before touching any electrical parts.
- Make sure that all wiring is secured, the specified wires are used, and that there is no strain on the terminal connections or wires. Improper connections or securing of wires may result in abnormal heat build-up or fire.
- When wiring the power supply and connecting the remote controller wiring and transmission wiring, position the wires so that the EL. COMPO. BOX lid can be securely fastened. Improper positioning of the EL. COMPO. BOX lid may result in electric shocks, fire or the terminals overheating.
- If refrigerant gas leaks during installation, ventilate the area immediately. Toxic gas may be produced if the refrigerant comes into contact with fire.
- After completing installation, check for refrigerant gas leakage. Toxic gas may be produced if the refrigerant gas leaks into the room and comes into contact with a source of fire, such as a fan heater, stove or cooker.
- Do not directly touch refrigerant that has leaked from refrigerant pipes or other areas, as there is a danger of frostbite.
- Do not allow children to climb on the outdoor unit or function unit and avoid placing objects on the unit. Injury may result if the unit becomes loose and falls.

Caution

- While following the instructions in this installation manual, install drain piping to ensure proper drainage and insulate piping to prevent condensation. Improper drain piping may result in indoor water leakage and property damage.
- Install the indoor, outdoor and function units, power cord and connecting wires at least 1 meter away from televisions or radios to prevent picture interference and noise. (Depending on the incoming signal strength, a distance of 1 meter may not be sufficient to eliminate noise.)
- Remote controller (wireless kit) transmitting distance can be shorter than expected in rooms with electronic fluorescent lamps (inverter or rapid start types). Install the indoor unit as far away from fluorescent lamps as possible.
- Make sure to provide for adequate measures in order to prevent that the outdoor unit be used as a shelter by small animals. Small animals making contact with electrical parts can cause malfunctions, smoke or fire. Please instruct the customer to keep the area around the unit clean.
- Do not install the air conditioner in the following locations:
 - Where there is a high concentration of mineral oil spray or vapour (e.g. a kitchen). Plastic parts will deteriorate, parts may fall off and water leakage could result.
 - Where corrosive gas, such as sulphurous acid gas, is produced. Corroding of copper pipes or soldered parts may result in refrigerant leakage.
 - Near machinery emitting electromagnetic radiation. Electromagnetic radiation may disturb the operation of the control system and result in a malfunction of the unit.
 - Where flammable gas may leak, where there is carbon fibre or ignitable dust suspensions in the air, or where volatile flammables such as paint thinner or gasoline are handled. Operating the unit in such conditions may result in fire.

1-2 Special notice of product

[CLASSIFICATION]

This air conditioner comes under the term “appliances not accessible to the general public”.

[EMC CHARACTERISTICS]

This system is a class A product. In a domestic environment this product may cause radio interference in which case the user may be required to take adequate measures.

[REFRIGERANT]

This system use R410A refrigerant.

- The refrigerant R410A requires that strict precautions be observed for keeping the system clean, dry and tightly sealed. Read the chapter “REFRIGERANT PIPING” carefully and follow these procedures correctly.
 - Clean and dry
Strict measures must be taken to keep impurities (including SUNISO oil and other mineral oils as well as moisture) out of the system.
 - Tightly sealed
Take care to keep the system tight when installing. R410A contains no chlorine, does not destroy the ozone layer and so does not reduce the earth’s protection against harmful ultraviolet radiation. R410A will contribute only slightly to the greenhouse effect if released into the atmosphere.
- Since R410A is a mixed refrigerant, the required additional refrigerant must be charged in its liquid state. (If the system is charged with refrigerant in its gaseous state, due to composition change, the system will not function normally).

Limit by the total maximum refrigerant charge

The total maximum refrigerant charge of a VRV system must be below 100kg, this to be in accordance with CE requirement (EN60335-2-40 standard).

This means that in case the total maximum refrigerant charge of the system (factory and additional charge) is equal to or more than 100kg you must divide your multiple outdoor system into smaller independent systems, each containing less than 100kg refrigerant charge.

For factory charge, refer to the unit name plate.

Important information regarding the refrigerant used

This product contains fluorinated greenhouse gases covered by the Kyoto Protocol. Do not vent gases into the atmosphere.

Refrigerant type : R410A

GWP ⁽¹⁾ value : 1975

⁽¹⁾ GWP = global warming potential

Please fill in with indelible ink,

- ① the factory refrigerant charge of the product,
- ② the additional refrigerant amount charged in the field and
- ① + ② the total refrigerant charge on the refrigerant charge label supplied with the product.

The filled out label must be adhered in the proximity of the product charging port (e.g. onto the inside of the service cover).

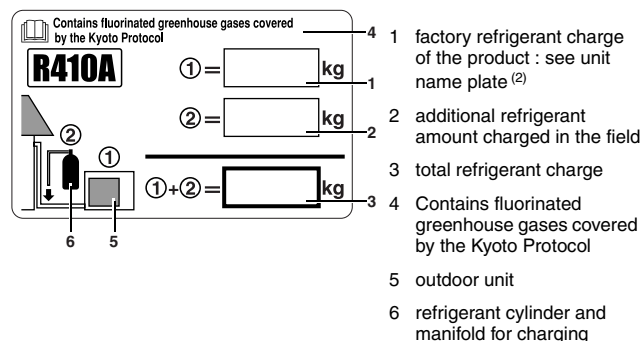

⁽²⁾ In case of multiple outdoor systems, only 1 label must be adhered, mentioning the total factory refrigerant charge of all outdoor units connected on the refrigerant system.

[DESIGN PRESSURE]

Since design pressure is 4.0MPa or 40bar (for R407C units : 3.3MPa or 33bar), the wall thickness of pipes should be more carefully selected in accordance with the relevant local and national regulations.

1-3 Disposal requirements

Disposal requirements

Dismantling of the unit, treatment of the refrigerant, of oil and of other parts must be done in accordance with relevant local and national legislation.

2. INTRODUCTION

Note

- This manual provides information on the installation of the outdoor unit and function unit. Follow the instructions provided in the manual and install both the outdoor unit and function unit.
- For the installation of the indoor unit, refer to the installation manual provided with the indoor unit.
- Option accessories (sold separately) are required for the installation of the products. Refer to “2-6 Option accessory” for details.

2-1 About product

- RTSYQ-P series are designed for outdoor installation and used for cooling and heating applications. The outdoor system consists of the RTSQ8-16P outdoor unit and BTSQ20P function unit in combination.

Only the outdoor unit or function unit cannot be used independently. Refer to “2-4 Combination” for concrete system configurations.

With this system, rated cooling capacity from 28.0kW to 55.9kW and rated heating capacity from 31.5kW to 62.5kW can be achieved.

- The indoor units that combined with RTSYQ-P system for air conditioning are Daikin VRV series indoor units that compatible with R410A. To learn which indoor units are compatible with R410A, refer to the product catalogs. To combine with other refrigerant indoor unit will cause malfunction.

2-2 Technical and Electrical specifications

Refer to the Engineering Data Book for the complete list of specifications.

2-3 Main components

For main components and function of the main components, refer to the Engineering Data Book.

2-4 Combination

- The following table shows a list of system names, system configuration models, and the capacity of each connectable indoor unit.

<Single outdoor unit system>

System name	Composition unit		Total capacity of indoor units
	Outdoor unit	Function unit	
RTSYQ10PY1	RTSQ10PY1	BTSQ20PY1	125 - 325
RTSYQ14PY1	RTSQ14PY1	BTSQ20PY1	175 - 455
RTSYQ16PY1	RTSQ16PY1	BTSQ20PY1	200 - 520

* The RTSQ8P or RTSQ12P unit cannot be used as a configuration unit of single outdoor unit system.

<Multi outdoor unit system>

System name	Composition unit		Total capacity of indoor units
	Outdoor unit	Function unit	
RTSYQ20PY1	RTSQ8PY1 RTSQ12PY1	BTSQ20PY1	250 - 650

* The RTSQ10P, RTSQ14P, or RTSQ16P unit cannot be used as a configuration unit of the multi outdoor unit system.

* The BHFP30AC56 outdoor unit multi connection piping kit (sold separately) is required for the piping connections of two outdoor units.

Note

- Install the function unit on the right-hand side of the outdoor unit. If the order of arrangement differs, the shape of the provided piping will not be compatible, in which case a substitute connection pipe will be required on site.

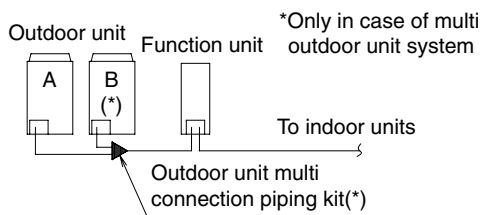









- If the total capacity of the connected indoor units exceeds the capacity of the outdoor unit, cooling and heating performance may drop when running the indoor units. See the capacity table in the Engineering Data Book for details.





2-5 Standard supplied accessories

Confirm the following accessories are included. The storage location of the accessories is shown in figure 1.



< Accessories included in outdoor unit >

Name	Clamp			Manuals, etc.
	(1)	(2)	(3)	
Quantity	11 pcs.	2 pcs.	1 pc.	1 pc. about each item
Shape	 (Small)		 (Large)	<ul style="list-style-type: none"> Operation manual Installation manual "REQUEST FOR THE INDICATION" label (Installation records) "ADDITIONAL REF. CHARGE" label

Name	Gas side accessory pipe				
	(1)	(2)	(3)	(4)	
Quantity	8 type	1 pc.	1 pc.	1 pc.	2 pcs.
	10 type			2 pcs.	
	12 type			2 pcs.	
	14 · 16 type			3 pcs.	
Shape				 φ25.4	 φ22.2

Name	Liquid side accessory pipe			Equalizer side accessory pipe	
	(1)	(2)	(3)	(1)	(2)
Quantity	8 type	1 pc.	1 pc.	2 pcs.	1 pc.
	10 type			2 pcs.	
	12 type			2 pcs.	
	14 · 16 type			2 pcs.	
Shape			 φ12.7	 φ9.5	

< Accessories included in function unit >

Name	Gas side accessory pipe(5)	Liquid side accessory pipe(4)
Quantity	2 pcs.	2 pcs.
Shape	 φ25.4	 φ12.7

(Refer to figure 1)

- Clamps, Manuals, etc.
- Accessory pipes

Note

- Accessories are divided separately for the outdoor unit and function unit. Check the accessories for both units.
- Do not throw away any of the accessories until installation is complete. They are needed for installation work. Request the user to keep the explanation documents after the installation work is completed.

2-6 Option accessory

To install the outdoor units, the following optional parts are also required. To select an optimum kit, refer to "6. REFRIGERANT PIPING".

- Refrigerant branching kit

REFNET header	KHRP26M22H	KHRP26M33H	KHRP26M72H
REFNET joint	KHRP26A22T	KHRP26A33T	KHRP26A72T

- Outdoor unit connection piping kit

Kit name	BHFP30A56
----------	-----------

- Pipe size reducer

for REFNET header	KHRP26M73HP
-------------------	-------------

Note

- Make sure that any separately purchased accessories are designed for use with R410A.
- The outdoor unit multi connection piping kit is required for the multi outdoor unit system only.

3. SELECTION OF LOCATION

Select a location for installation that meets the following conditions and get the customer's permission.

- (1) There is no danger of fire due to leakage of inflammable gas.
- (2) Select the location of the unit in such a way that neither the discharged air nor the sound generated by the unit disturb anyone.
- (3) The foundation is strong enough to support the weight of the unit and the floor is flat to prevent vibration and noise generation.
- (4) The piping length between the outdoor unit and the indoor unit may not exceed the allowable piping length.
(Refer to "6. REFRIGERANT PIPING")
- (5) Locations where the unit's suction vent and outlet vent do not generally face the wind.
Wind blowing directly into the suction or outlet vents will interfere with the unit's operation.
If necessary, install some kind of obstruction to block the wind.
- (6) The space around the unit is adequate for servicing and the minimum space for air inlet and air outlet is available.
(See the "Installation Space Examples" for the minimum space requirements.)

Installation Space Examples

- The installation space requirement shown in figure 2 is a reference for cooling operation when the outdoor temperature is 35°C. If the design outdoor temperature exceeds 35°C or the heat load exceeds maximum capacity in all the outdoor unit, take an even large space on the intake shown in figure 2.
- During installation, install the units using the most appropriate of the patterns shown in figure 2 for the location in question, taking into consideration human traffic and wind.
If the number of units installed is more than that shown in the pattern in figure 2, install the units so there are no short circuits.
- As regards space in front of the unit, consider the space needed for the local refrigerant piping when installing the units.
- If a snowbreak hood (sold separately) is mounted, secure the required space of installation including the outer dimensions of the product and snowbreak hood.
- If the work conditions in figure 2 do not apply, contact your dealer or Daikin directly.

(Refer to figure 2)

1. In case of single outdoor unit system
2. In case of multi outdoor unit system
3. Pattern 1
4. Pattern 2
5. Pattern 3
6. Front side
7. No limit to wall height
8. Service space of front side
9. Service space of suction side

For Patterns 1 and 2 in figure 2 :

- Wall height for front side – no higher than 1500 mm.
- Wall height on the suction side – no higher than 500 mm.
- Wall height for sides – no limit.

If the height is exceeded the above, calculate h1 and h2 shown in the figure below, and add h2/2 to the service space of front side and h1/2 to the service space of suction side.

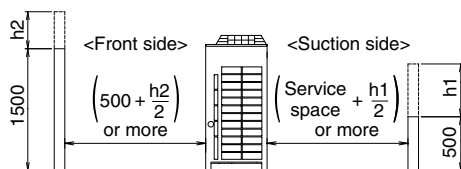

Note

- (1) An inverter air conditioner may cause electronic noise generated from AM broadcasting. Examine where to install the main air conditioner and electric wires, keeping proper distances away from stereo equipment, personal computers, etc. Particularly for locations with weak reception, ensure there is a distance of at least 3 meters for indoor remote controllers, place power wiring and transmission wiring in conduits, and ground the conduits.

(Refer to figure 3)

1. Indoor unit
 2. Branch switch, overcurrent breaker
 3. Remote controller
 4. Personal computer or radio
 5. Air outlet
 6. Rear side suction grill
- (2) When installing in a locations where there is heavy snowfall, implement the following snow measures.
 - Install the outdoor unit and function unit on a mount (procured locally) so that they may not be buried or covered with snowfall while the bottom frame will be 200 to 300 mm higher than the surface of the deposited snow.
 - Mount the snowbreak hood (sold separately) and dismount the rear suction grille (see fig. 3).
 - (3) When mounting the snowbreak hood (sold separately) to the air inlet, make sure that the air outlet of the snow protection food will be located right angles to the winter wind or in the leeward direction.
 - (4) If the outdoor temperature of the place of installation is low in winter and defrost water discharged from the system freezes while the system is in defrost operation in heating mode, provide a sufficient space between the bottom frame of the outdoor unit and the foundation side. (A space of 500 to 1000 mm is recommended.)
 - (5) If condensate may drip on downstairs (or walkway) depending on the floor condition, take a measure such as the installation of drain pan (field supply).
 - (6) The refrigerant R410A itself is nontoxic, nonflammable and is safe. If the refrigerant should leak however, its concentration may exceed the allowable limit depending on room size. Due to this it could be necessary to take measures against leakage. See "12. CAUTION FOR REFRIGERANT LEAKS" for details.

4. INSPECTING AND HANDLING THE UNIT

- At delivery, the package should be checked and any damage should be reported immediately to the carrier claims agent.
- When handling the unit, take into account the following:

- (1)  Fragile, handle the unit with care.

 Keep the unit upright in order to avoid compressor damage.

- (2) Decide on the transportation route.

- (3) If hanging the unit, keep the following points in mind and hang the unit following the procedure shown in figure 4.
 - Use a sling sufficiently strong to hold the mass of the unit.
 - Use 2 sling of at least 8m long.
 - Place extra cloth or boards in the locations where the casing comes in contact with the sling to prevent damage.
 - Hoist the unit making sure it is being lifted at its center of gravity.

In the case of transporting the outdoor unit by forklift, insert the fork into the opening (large) under the bottom of the outdoor unit.

(Refer to figure 5)

The function unit is not provided with any opening for fork insertion.

Note

- Apply a filler cloth on a fork to prevent coating of the bottom frame from coming off and rust from occurring when bringing the unit using a forklift.

- (4) After the outdoor unit is installed, remove the transportation bracket (yellow) mounted to the opening (large) of the outdoor unit. (Refer to figure 5)

(Refer to figure 4)

1. Slings procedure for outdoor unit
2. Slings procedure for function unit
3. Sling
4. Patch plate or path cloth
5. Opening (large)
6. Opening (small)

(Refer to figure 5)

1. Fork insertion place (outdoor unit only)
2. Fork
3. Opening (large)
4. Transportation bracket (yellow)
5. Transportation bracket fixing screw

5. PLACING THE UNIT

- Make sure the unit is installed level on a sufficiently strong base to prevent vibration and noise. (Refer to figure 6 and 7)
- The base should support the unit with the extent larger than hatched area in figure 6 and 7.
If protective rubber is to be attached, attach it to the whole face of the base.
- The height of the base should be at least 150mm from the floor.
- Secure the unit to its base using foundation bolts. (Use four commercially available M12-type foundation bolts, nuts, and washers.)
- The foundation bolts should be inserted 20 mm.

(Refer to figure 6)

1. Basic shape of outdoor unit and position of foundation bolt
2. Center of product
3. Product depth
4. Basic size
5. Four, 15 × 22.5 eclipse hole (foundation bolt hole)

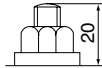

Model	A	B
RHSQ8 · 10 · 12 Type	930	792
RHSQ14 · 16 Type	1240	1102

(Refer to figure 7)

1. Basic shape of function unit and position of foundation bolt

Note

- When installing on a roof, make sure the roof floor is strong enough and be sure to water-proof all work.
- Make sure the area around the machine drains properly by setting up drainage grooves around the foundation.
Drain water is sometimes discharged from the outdoor unit when it is running.

6. REFRIGERANT PIPING

Note

- All field piping must be installed by a licensed refrigeration technician and must comply with relevant local and national regulations.
- After piping work is complete, do not open the shutoff valve under any circumstances until "7. FIELD WIRING" and "8. TESTS AND INSULATION WORK" are complete.
- Do not use flux when brazing the refrigerant piping. Use the phosphor copper brazing filler metal (BCuP-2 : JIS Z 3264, B-Cu93P-710/795 : ISO 3677) which does not require flux.
(Flux has extremely harmful influence on refrigerant piping systems. For instance, if the chlorine based flux is used, it will cause pipe corrosion or, in particular, if the flux contains fluorine, it will damage the refrigerant oil.)

6-1 Selection of piping material and Refrigerant branching kit

- Use only pipes which are clean inside and outside and which do not accumulate harmful sulfur, oxidants, dirt, cutting oils, moisture, or other contamination. (Foreign materials inside pipes including oils for fabrication must be 30mg/10m or less.)
- Use the following items for the refrigerant piping.

Material : Jointless phosphor-deoxidized copper pipe

Size : See "6-5 Example of connection" to determine the correct size.

Thickness : Select a thickness for the refrigerant piping which complies with national and local laws.

For R410A, the design pressure is 4.0 MPa (40-bar).

The minimum thickness of piping according to Japan's High-Pressure Gas Safety Law (as of January 2003) is shown below.

Temper grade (O type, 1/2H type) in the table indicate the material types specified in JIS H 3300.

(unit : mm)

Temper grade	O type			
	outer diameter	φ6.4	φ9.5	φ12.7
smallest thickness	0.80	0.80	0.80	0.99

(unit : mm)

Temper grade	1/2H type							
	outer diameter	φ19.1	φ22.2	φ25.4	φ28.6	φ31.8	φ34.9	φ38.1
smallest thickness	0.80	0.80	0.88	0.99	1.10	1.21	1.32	1.43

- For piping work, follow the maximum tolerated length, difference in height, and length after a branch indicated in the "6-5 Example of connection".
- Outdoor unit multi connection piping kit and refrigerant branching kit (sold separately) are needed for connection of piping between outdoor units (in case of multi system) and piping branches.
Use only separately sold items selected specifically according to the outdoor unit multi connection piping kit, the refrigerant branching kit selection in the "6-5 Example of connection".

6-2 Protection against contamination when installing pipes

Protect the piping to prevent moisture, dirt, dust, etc. from entering the piping.

Place	Installation period	Protection method
Outdoor	More than a month	Pinch the pipe
	Less than a month	
Indoor	Regardless of the period	Pinch or tape the pipe

Note

Exercise special caution to prevent dirt or dust when passing piping through holes in walls and when passing pipe edges to the exterior.

6-3 Pipe connection

- Be sure to perform nitrogen permutation or nitrogen blow when brazing. (Refer to figure 8)
Brazing without performing nitrogen permutation or nitrogen blow into the piping will create large quantities of oxidized film on the inside of the pipes, adversely affecting valves and compressors in the refrigerating system and preventing normal operation.

(Refer to figure 8)

1. Refrigerant pipe
2. Location to be brazed
3. Nitrogen
4. Taping
5. Handy valve
6. Regulator

- The pressure regulator for the nitrogen released when doing the brazing should be set to about 0.02 MPa (0.2kg/cm² : Enough to feel a slight breeze on your cheek).

Prohibition

Do not use anti-oxidants when brazing the pipe joints.
Residue can clog pipes and break equipment.

6-4 Connecting the refrigerant piping

1. Direction to bring out the pipes

The pipes (liquid, gas, and equalizer pipes) between outdoor units in the case of the outdoor unit multi system, the pipes (liquid and gas pipes) between the outdoor and function units, and the connecting pipes (liquid and gas pipes) between the function and indoor units can be taken out from the front or lower sides of the units as shown in fig. 9.

When passing out through the bottom, use the knock hole in the bottom frame.

(Refer to figure 9)

1. Outdoor unit
2. Function unit
3. Front connections
4. Bottom connections
5. To indoor unit

Precautions when knocking out knock holes

- Open knock hole in the base frame by drilling the concave around it with a 6mm bit. (Refer to figure 10)

(Refer to figure 10)

1. For outdoor unit
2. For functional unit
3. Knock hole (large) for liquid and gas pipes
4. Drill (6 mm dia.)
5. Dent (four points)
6. Knock hole (large and small) for liquid and gas pipes on outdoor unit side
7. Knock hole (large and small) for liquid and gas pipes for indoor unit side
8. Dent (two points)
9. Knock hole (small) for equalizer pipe
(Only use in case of multi outdoor unit system)

- Be sure to avoid damaging the casing
- After knocking out the holes, we recommend you remove any burrs and paint them using the repair paint to prevent rusting.
- When passing electrical wiring through the knock holes, protect the wiring with a conduit or bushings, making sure not to damage the wiring.

2. Removing Pinch Piping

- When connecting refrigerant piping to an outdoor unit or function unit, remove the pinch piping using the procedure in the figure 11 or the figure 12.
- About handling of shutoff valves, refer to [Shutoff valve operation procedure] in "9-1 Before working".

⚠ Caution

After removing the gass, remove the pinch piping.
Any gas remaining inside may blow off the pinch piping when you dis-solve the brazing, causing damage.

(Refer to figure 11)

1. Removal procedure for pinch piping of outdoor unit
2. Pinch pipe A
3. Pinch pipe B
4. Pinch pipe C (*)
5. Never remove the relay pipe.
6. Never remove this pinch pipe.
7. Step 1: Check that the stop valve is closed.
8. Step 2: Connect the charge hose to the stop valve, and extract the gas in the pinch piping.
9. After the gas is extracted, melt the blazing material with a burner and remove the pinch pipes.
10. Pinch pipe
(*) The pinch pipes to be removed varies with the system.
Refer to the following table and remove the corresponding pinch pipes.

System type	Outdoor unit name	Pinch pipes to be removed
Single outdoor unit system	RTSQ10 · 14 · 16PY1	Pinch pipes A and B
Multi outdoor unit system	RTSQ8 · 12PY1	Pinch pipes A and B, C

(Refer to figure 12)

1. Removal procedure for pinch piping of function unit
 2. Pinch pipes (x4)
 3. Step 1: Cut the port piping connected to the pinch piping with an appropriate tool, such as a pipe cutter.
Then extract the gas in the pinch piping.
 4. Step 2: After the gas is extracted, melt the blazing material with a burner and remove the pinch pipes.
3. Connecting refrigerant piping to outdoor units and function unit
- Figure 13 shows a connection example of refrigerant piping to the outdoor unit in the case of the single outdoor unit system.
Figure 14 shows a connection example of refrigerant piping to the outdoor units in the case of the multi outdoor unit system.
Figure 15 shows a connection example of refrigerant piping to the function unit.
 - For the detailed connection method of the outdoor units in the case of the multi outdoor unit system, follow the instructions in "4. Piping Connections between Outdoor Units" and the installation manual provided with the outdoor unit multi connection piping kit (sold separately).

Note

- The equalizer piping connects the outdoor units in the case of the multi outdoor unit system. There are no connections to the function unit.
- The L-shaped joint (locally arranged) with a diameter of 19.1 mm is required to connect the refrigerant piping to the outdoor unit, gas pipe shutoff valve and gas side accessory pipe (2), and the connecting piping of the equalizer shutoff valve and equalizer side accessory pipe (2).
- The liquid pipe, gas pipe, equalizer pipe (for the multi outdoor unit system only), and some L-shaped joints to be connected to the provided piping should be procured locally.
- Make sure the onsite piping does not come into contact with other piping or the bottom frame or side panels of the unit.

(Refer to figure 13)

1. Bottom connections
2. Front connections
3. Gas pipe shutoff valve
4. Liquid pipe shutoff valve
5. Liquid side accessory pipe (1)
6. Liquid side accessory pipe (2)
7. Gas side accessory pipe (1)
8. Gas side accessory pipe (2)
9. Gas side accessory pipe (3) (*1)
10. L-shaped joint (procured locally)
11. Piping on liquid side (procured locally)
12. Piping on gas side (procured locally)
13. Blazing
14. To function unit

(Refer to figure 14)

1. Bottom connections
2. Front connections
3. Liquid pipe shutoff valve
4. Gas pipe shutoff valve
5. Equalizer shutoff valve
6. Liquid side accessory pipe (1)
7. Liquid side accessory pipe (2)
8. Gas side accessory pipe (1)
9. Gas side accessory pipe (2)
10. Gas side accessory pipe (3) (*2)
11. Equalizer side accessory pipe (1)
12. Equalizer side accessory pipe (2)
13. L-shaped joint (procured locally)
14. Blazing

(Refer to figure 15)

1. Bottom connections
2. Front connections
3. Liquid side accessory pipe (3)
4. Liquid side accessory pipe (4)
5. Gas side accessory pipe (3) (*3)
6. Gas side accessory pipe (3) (*3) (*4)
7. Gas side accessory pipe (4)
8. Gas side accessory pipe (5)

9. Piping on liquid side (procured locally)
10. Piping on gas side (procured locally)
11. Blazing
12. To outdoor unit
13. To indoor unit

(*1) RTSQ14P and RTSQ16P units only (procured locally for others)

(*2) RTSQ12P unit only (procured locally for other)

(*3) RTSYQ14P to RTSYQ20P systems only (procured locally for others)

(*4) <For RTSYQ14P and RTSYQ16P systems>

Refer to figure 16 and the following table, and cut the gas side accessory pipe (3).

<RTSYQ20P system>

Refer to the installation manual of the outdoor unit connection piping kit and cut the gas side accessory pipe (3).

(Refer to figure 16)

1. Gas side accessory pipe (3) (Indoor side)
2. Cut to 130 mm.
3. Gas side accessory pipe (3) (Outdoor side)
4. Cut to 73 mm.
5. Function unit
6. Outdoor unit
7. Connecting piping on gas side (procured locally)
8. To indoor units

System name	Required dimensions for gas side accessory pipe (3)	
	Outdoor side	Indoor side
RTSYQ14 · 16P type	73mm	130mm

Note

- The dimensions shown in above table are required when installing the piping (procured locally) on the gas side of the outdoor unit in the position shown in figure 16. Refer to the table above and make necessary size adjustment if the working conditions of the on-site piping on the gas side differ.

4. Piping Connections between Outdoor Units (for Multi Outdoor Unit System Only)

- Observe the restrictions specified below to connect the outdoor units.
- The outdoor unit multi connection piping kit (sold separately) is required for the connection of the piping between the outdoor units. For the installation of the outdoor unit multi connection piping kit, refer to the installation manual provided with the kit. Unless the kit is installed properly, the outdoor units may malfunction or fail to operate.

(1) About outdoor unit multi connection piping kit

- Install the joint horizontally so that the attached warning label faces straight up, and the tilt is within $\pm 15^\circ$.

(Refer to figure 17-1)

Do not install vertically. (Refer to figure 17-2)

- Maintain a straight portion of 500 mm or more until the split of the joint without wrapping any onsite piping around this area.

Over 500 mm of straight area can be maintained by connecting at least 120 mm of onsite pipe (straight) to the joint.

(Refer to figure 17-3)

(Refer to figure 17)

1. Warning label
2. Horizontal surface
3. $\pm 15^\circ$ or less
4. Ground
5. A-arrow view
6. B-arrow view
7. Onsite pipe (120mm length or more)
8. Straight part of 500mm or more

- (2) Install the piping between the outdoor units horizontally or with a rising gradient toward outdoor unit A from outdoor unit B in order to prevent oil remaining in the piping.

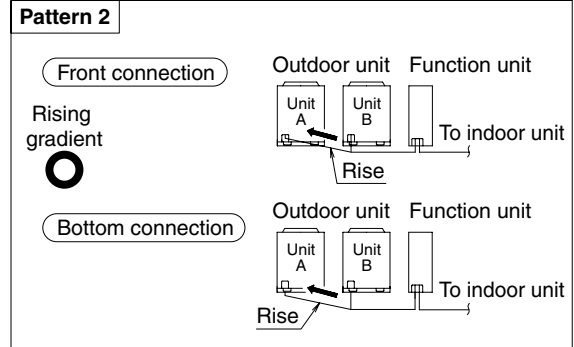
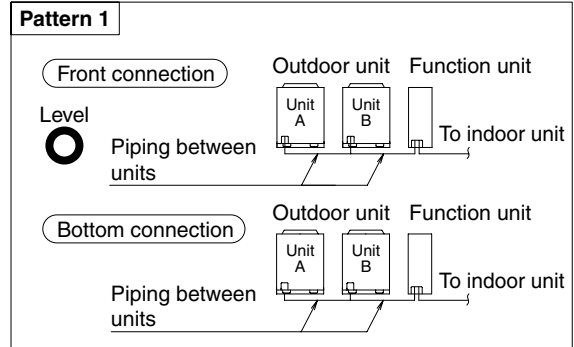

Change to pattern 1 or pattern 2

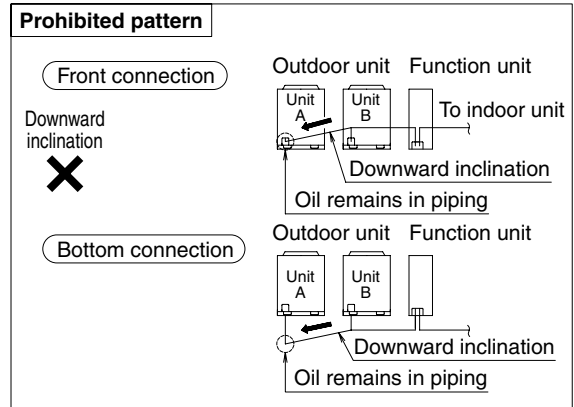

- (3) To avoid the risk of oil detention in the stopping unit, always connect the shutoff valve and the piping between outdoor units as shown A or B in the figure below.

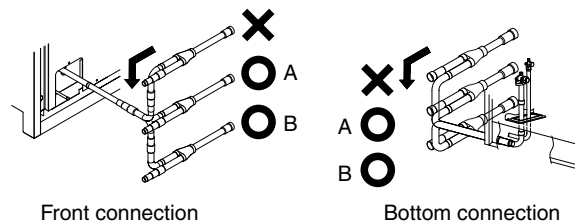

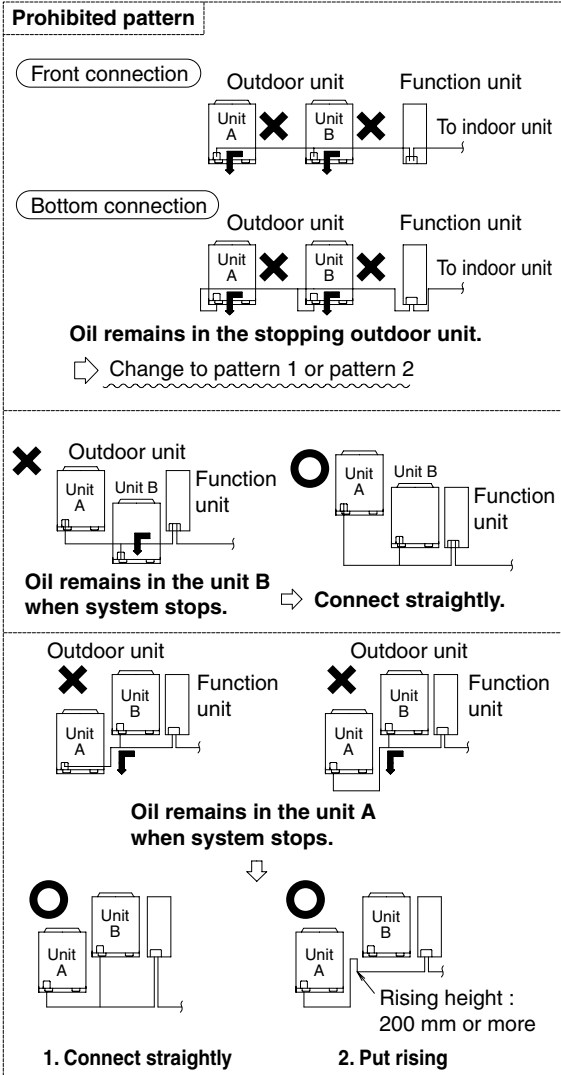

- (4) If the piping length between the outdoor units exceeds 2 m, create a rise of 200 mm or more in the gas piping under a length of 2 m from the outdoor unit multi connection piping kit.

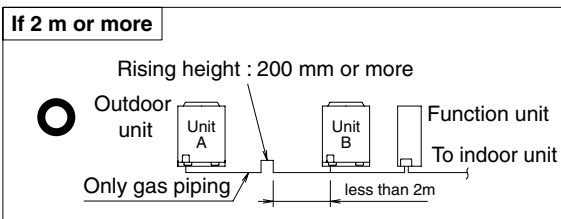
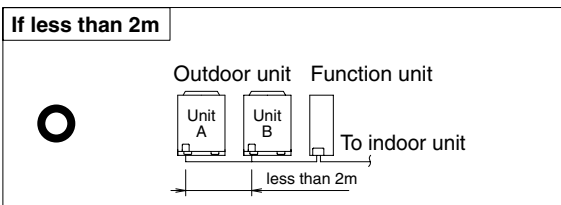

5. Branching the refrigerant piping

Heed the restrictions below when installing the refrigerant branching kit and read the installation instruction manual with the kit. (Improper installation could lead to malfunctioning or breakdown of the outdoor unit.)

<REFNET joint>

Install the REFNET joint so it splits horizontally or vertically.

(Refer to figure 18)

1. Horizontal
2. A-arrow view
3. Horizontal surface
4. $\pm 30^\circ$ or less
5. Vertical

<REFNET header>

Install the REFNET header so it splits horizontally.

(Refer to figure 19)

1. Horizontal surface
2. B-arrow view

6-5 Example of connection

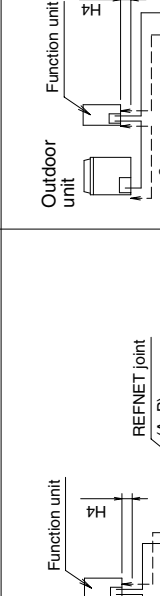
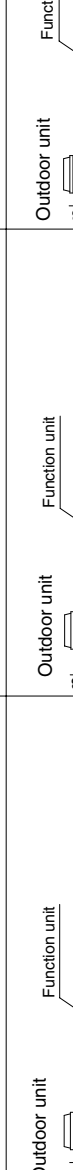
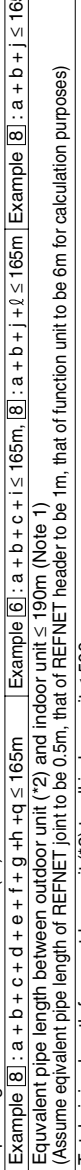
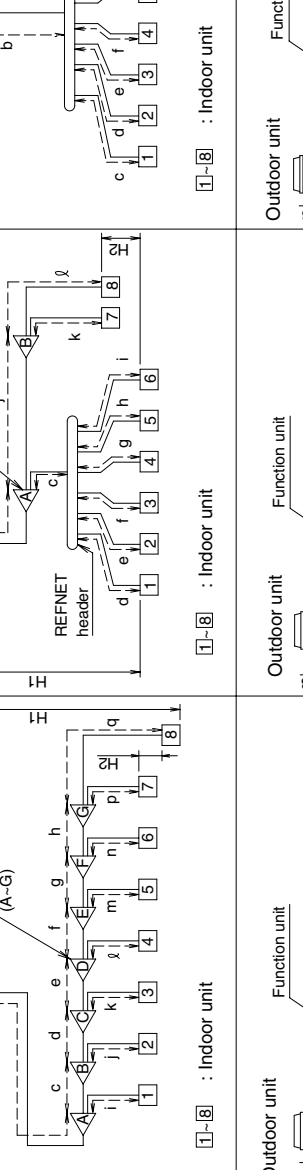
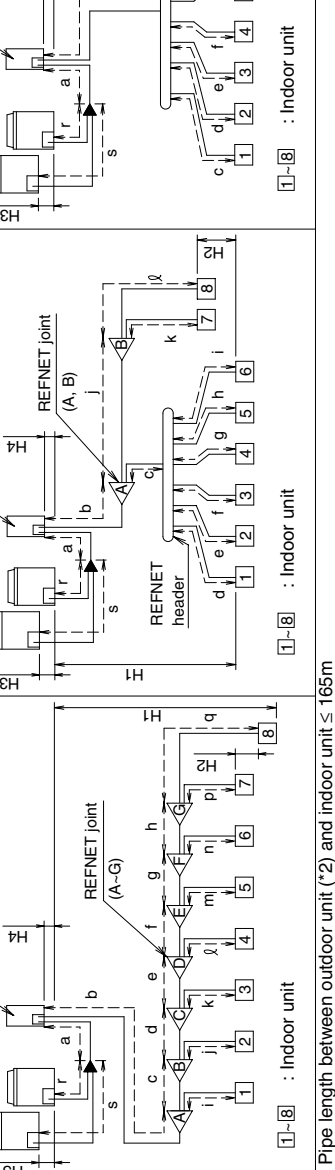
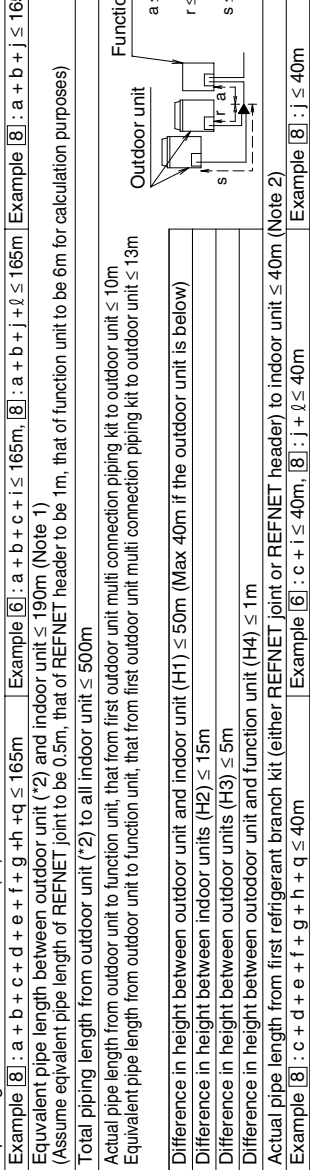
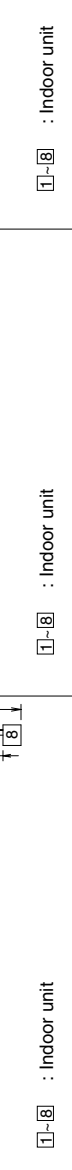
<p>Example of connection (Connection of 8 indoor units)</p> <p>(*1) " ← " Indicate the Outdoor unit multi connection piping kit. (*2) In case of multi outdoor system, re-read "outdoor unit" to "Outdoor unit multi connection piping kit" as seen from the indoor unit.</p>	<p>Single outdoor system</p> 	<p>Branch with REFNET joint and header</p> 	<p>Branch with REFNET header</p> 	
<p>Multi outdoor system</p> 	<p>Branch with REFNET joint and header</p> 	<p>Branch with REFNET header</p> 		
	<p>Actual pipe length</p>	<p>Pipe length between outdoor unit (*2) and indoor unit ≤ 165m Example [6]: a + b + c + d + e + f + g + h + q ≤ 165m</p>		
	<p>Equivalent length</p>	<p>Equivalent pipe length between outdoor unit (*2) and indoor unit ≤ 190m (Note 1) (Assume equivalent pipe length of REFNET joint to be 0.5m, that of REFNET header to be 1m, that of function unit to be 6m for calculation purposes)</p>		
	<p>Total extension length</p>	<p>Total piping length from outdoor unit (*2) to all indoor unit ≤ 500m</p>		
	<p>Actual and Equivalent pipe length</p>	<p>Actual pipe length from outdoor unit to function unit, that from first outdoor unit multi connection piping kit to outdoor unit ≤ 10m Equivalent pipe length from outdoor unit to function unit, that from first outdoor unit multi connection piping kit to outdoor unit ≤ 13m</p>		
	<p>Difference in height</p>	<p>Difference in height between outdoor unit and indoor unit (H1) ≤ 50m (Max 40m if the outdoor unit is below)</p>		
	<p>Difference in height</p>	<p>Difference in height between indoor units (H2) ≤ 15m</p>		
	<p>Difference in height</p>	<p>Difference in height between outdoor units (H3) ≤ 5m</p>		
	<p>Difference in height</p>	<p>Difference in height between outdoor unit and function unit (H4) ≤ 1m</p>		
	<p>Actual pipe length</p>	<p>Actual pipe length from first refrigerant branch kit (either REFNET joint or REFNET header) to indoor unit ≤ 40m (Note 2) Example [8]: c + j ≤ 40m, [8]: j + ℓ ≤ 40m</p>		
	<p>Allowable height difference</p>			
	<p>Allowable length after the branch</p>	<p>Example [8]: j ≤ 40m</p>		

Outdoor unit multi connection piping kit and Refrigerant branch kit selection

- Refrigerant branch kits can only be used with R410A.
- When multi outdoor system are installed, be sure to use the special separately sold Outdoor unit multi connection piping kit. (BHPF30A56).
(For how to select the proper kit, follow the table at right.)

How to select the REFNET joint

- When using REFNET joint at the first branch counted from the outdoor unit side, choose from the following table in accordance with the outdoor system capacity type. (Example : REFNET joint A)

Outdoor system capacity type	Refrigerant branch kit name
10HP type	KHRP26A33T
14-20HP type	KHRP26A72T

- Choose the REFNET joints other than the first branch from the following table in accordance with the total capacity index of all the indoor units connected below the REFNET joint.

Indoor unit total capacity index	Refrigerant branch kit name
x < 200	KHRP26A22T
200 ≤ x < 290	KHRP26A33T
290 ≤ x < 640	KHRP26A72T

How to select the REFNET header

- Choose from the following table in accordance with the total capacity index of all the indoor units connected below the REFNET header.
- 250 type indoor unit can not be connected below the REFNET header.

Indoor unit total capacity index	Refrigerant branch kit name
x < 200	KHRP26M22H or KHRP26A33H
200 ≤ x < 290	KHRP26M33H
290 ≤ x < 640	KHRP26M72H
640 ≤ x	KHRP26M73H + KHRP26M73HP

How to select the outdoor unit multi connection piping kit

- (This is required when the system is multi outdoor unit system.)
- Choose from the following table in accordance with the number of outdoor units.

Number of outdoor unit	Connecting piping kit name
2 units	BHPF30AP56

Example for indoor units connected downstream

Pipe size selection

⚠ The thickness of the pipes in the table shows the requirements of Japanese High Pressure Gas Control law. (As of Jan. 2003)
The thickness and material shall be selected in accordance with local code.

<In case of single outdoor unit system>

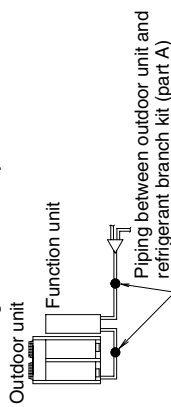

<In case of multi outdoor unit system>

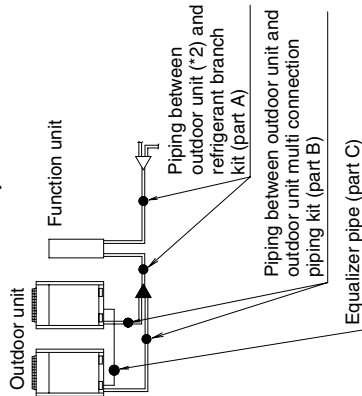

Example REFNET joint C : Indoor units [3] + [4] + [5] + [6] + [7] + [8]
Example REFNET joint B : Indoor units [7] + [8]
Example REFNET header : Indoor units [1] + [2] + [3] + [4] + [5] + [6]
Indoor units [1] + [2] + [3] + [4] + [5] + [6] + [7] + [8]

Piping between outdoor unit (*2) and refrigerant branch kit (part A)

- Choose from the following table in accordance with the outdoor unit system capacity type.

Outdoor system capacity type	Gas pipe	Liquid pipe
10HP type	φ22.2	φ9.5
14, 16HP type	φ28.6	φ12.7
20HP type		φ15.9

Piping between outdoor unit multi connection piping kit and outdoor unit (part B)

- Choose from the following table in accordance with the capacity type of the outdoor unit connected.

Outdoor unit capacity type	Gas pipe	Liquid pipe
RTSP8 type	φ22.2	φ9.5
RTSP12 type	φ28.6	φ12.7

Piping between refrigerant branch kits

- Choose from the following table in accordance with the total capacity type of all the indoor units connected downstream.
- Do not let the connection piping exceed the main refrigerant piping size. (Part A).
If the piping size selected from the following table exceeds the piping size of part A, decide the piping size in either of the following methods.

- (1) Reduce the size of the connection piping to the piping size of part A.
- (2) Replace the piping of part A with piping that is a size larger (see the table in Note 1) so that it will be the same as the size of the connection piping.

Indoor capacity index	Gas pipe	Liquid pipe
x < 150	φ15.9	
150 ≤ x < 200	φ19.1	φ9.5
200 ≤ x < 290	φ22.2	
290 ≤ x < 420	φ28.6	φ12.7
420 ≤ x < 640		φ15.9

Piping between refrigerant branch kit, and indoor unit

- Match to the size of the connection piping on the indoor unit.

Indoor unit capacity type	Gas pipe	Liquid pipe
20 - 25 · 32 · 40 · 50 type	φ12.7	φ6.4
63 · 80 · 100 · 125 type	φ15.9	
200 type	φ19.1	φ9.5
250 type	φ22.2	

Equalizer pipe (part D) (multi outdoor unit system only)

Piping size (O. D.)	(unit : mm)
	φ19.1

Temper grade and wall thickness for pipes

(Temper grade, O type and 1/2H type indicate the material type specified in JIS H 3300.)

Copper tube O. D.	φ6.4	φ9.5	φ12.7	φ15.9	φ19.1	φ22.2	φ25.4	φ28.6	φ31.8	φ34.9	φ38.1	φ41.3
Temper grade	O type											
Wall thickness (Min. requirement)	0.80	0.80	0.80	0.99	0.80	0.80	0.80	0.88	0.99	1.10	1.21	1.43
	1/2H type											

How to calculate the additional refrigerant to be charged

Additional refrigerant to be charged : R(kg)
(R should be rounded off in units of 0.1 kg.)

$$R = \left[\begin{aligned} & \left(\frac{\text{Total length(m) of liquid piping size at } \phi 22.2}{0.37} \right) \times 0.37 + \left(\frac{\text{Total length(m) of liquid piping size at } \phi 19.1}{0.26} \right) \times 0.26 \\ & + \left(\frac{\text{Total length(m) of liquid piping size at } \phi 15.9}{0.18} \right) \times 0.18 + \left(\frac{\text{Total length(m) of liquid piping size at } \phi 12.7}{0.12} \right) \times 0.12 \\ & + \left(\frac{\text{Total length(m) of liquid piping size at } \phi 9.5}{0.059} \right) \times 0.059 + \left(\frac{\text{Total length(m) of liquid piping size at } \phi 6.4}{0.022} \right) \times 0.022 \end{aligned} \right] +$$

FOR THE SYSTEM	
SYSTEM NAME	THE AMOUNT OF REFRIGERANT
RTSYQ10PY1	—
RTSYQ14PY1	1.3kg
RTSYQ16PY1	2.3kg
RTSYQ20PY1	—

Example for refrigerant branch using REFNET joint and REFNET header for the systems and each pipe length as shown below.

System : RTSYQ20PY1
Independent outdoor unit : RTSQ8PY1, RTSQ12PY1
Function unit : BTSQ20PY1

a : $\phi 15.9 \times 10\text{m}$	e : $\phi 6.4 \times 10\text{m}$	i : $\phi 6.4 \times 10\text{m}$	r : $\phi 12.7 \times 5\text{m}$
b : $\phi 15.9 \times 30\text{m}$	f : $\phi 6.4 \times 20\text{m}$	j : $\phi 9.5 \times 20\text{m}$	s : $\phi 9.5 \times 10\text{m}$
c : $\phi 12.7 \times 20\text{m}$	g : $\phi 6.4 \times 20\text{m}$	k : $\phi 9.5 \times 10\text{m}$	
d : $\phi 6.4 \times 10\text{m}$	h : $\phi 6.4 \times 10\text{m}$	l : $\phi 9.5 \times 10\text{m}$	

$$R = [40 \times 0.18] + [25 \times 0.12] + [50 \times 0.059] + [80 \times 0.022] = 14.91 \rightarrow [14.9\text{kg}]$$

Round off in units of 0.1 kg.

Note 1. When the equivalent pipe length between outdoor ("2) and indoor units is 90m or more, the size of main pipes (figure on right) must be increased according to the right table.

System	Gas	Liquid
RTSYQ10 type	$\phi 22.2 \rightarrow \phi 25.4$ (*)	$\phi 9.5 \rightarrow \phi 12.7$
RTSYQ14 type	Not increased	$\phi 12.7 \rightarrow \phi 15.9$
RTSYQ16 type	$\phi 28.6 \rightarrow \phi 31.8$ (*)	$\phi 15.9 \rightarrow \phi 19.1$

(*) If available on the site, use this size. Otherwise, it can not be increased.

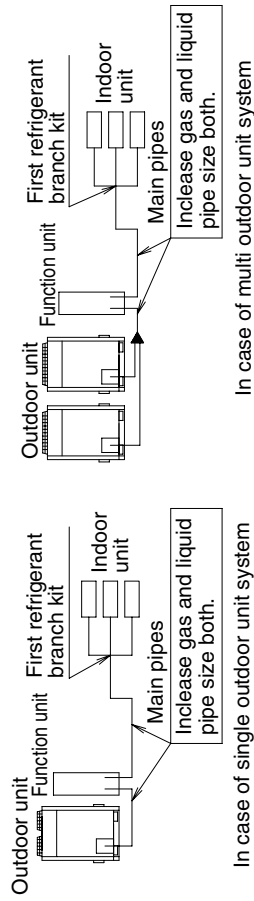

Note 2. Allowable length after the first refrigerant branch kit to indoor units is 40m or less, however it can be extended up to 90m if all the following conditions are satisfied.

Required Conditions	Example Drawings (In case of "Branch with REFNET joint")
1. It is necessary to increase the pipe size between the first branch kit and the final branch kit. (Reducers must be procured on site) However, the pipes that are same pipe size with main pipe must not be increased.	<p>8) $c + d + e + f + g + h + q \leq 90\text{m}$ increase the pipe size of c, d, e, f, g, h</p> <p>Increase the pipe size as follows $\phi 9.5 \rightarrow \phi 12.7$ $\phi 15.9 \rightarrow \phi 19.1$ $\phi 22.2 \rightarrow \phi 25.4$* $\phi 12.7 \rightarrow \phi 15.9$ $\phi 19.1 \rightarrow \phi 22.2$ $\phi 28.6 \rightarrow \phi 31.8$*</p>
2. For calculation of Total extension length, the actual length of above pipes must be doubled. (except main pipe and the pipes that are not increased)	$a + b + c \times 2 + d \times 2 + e \times 2 + f \times 2 + g \times 2 + h \times 2 + i + j + k + l + m + n + p + q \leq 500\text{m}$
3. Indoor unit to the nearest branch kit $\leq 40\text{m}$	$i, j, \dots, p, q \leq 40\text{m}$
4. The difference between [Outdoor unit to the farthest indoor unit] and [Outdoor unit to the nearest indoor unit] $\leq 40\text{m}$	The farthest indoor unit 8 The nearest indoor unit 1 $(a + b + c + d + e + f + g + h + q) - (a + b + i) \leq 40\text{m}$

*If available on the site, use this size. Otherwise it can not be increased.

7. FIELD WIRING



Caution

- All field wiring and components must be installed by a licensed electrician and must comply with relevant local and national regulations.
- Be sure to use a dedicated power circuit. Never use a power supply shared by another appliance.
- Never install a phase advancing capacitor. As this unit is equipped with an inverter, installing a phase advancing capacitor will not only deteriorate power factor improvement effect, but also may cause capacitor abnormal heating accident due to high-frequency waves.
- Only proceed with wiring work after blocking off all power.
- Always ground wires in accordance with relevant local and national regulations.
- This machine includes an inverter device. Connect earth and leave charge to eliminate the impact on other devices by reducing noise generated from the inverter device and to prevent leaked current from being charged in the outer hull of the product.
- Do not connect the ground wire to gas pipes, sewage pipes, lightning rods, or telephone ground wires.
Gas pipes : can explode or catch fire if there is a gas leak.
Sewage pipes : no grounding effect is possible if hard plastic piping is used.
Telephone ground wires and lightning rods : dangerous when struck by lightning due to abnormal rise in electrical potential in the grounding.
- Be sure to install an earth leakage circuit breaker.
 This unit uses an inverter, so install the earth leakage circuit breaker that be capable of handling high harmonics in order to prevent malfunctioning of the earth leakage circuit breaker itself.
- Earth leakage circuit breaker which are especially for protecting ground-faults should be used in conjunction with main switch or fuse for use with wiring. Make sure that the capacity is the same as or more than the rated capacity of the fuse or breaker in that case.

Note

- Electrical wiring must be done in accordance with the wiring diagrams and the description herein.
- Do not operate until refrigerant piping work is completed. (If operated before complete the piping work, the compressor may be broken down.)
- This product have reversed phase protection detector that only works when the power is turned on. If there exists black out or the power goes on and off which the product is operating, attach a reversed phase protection circuit locally. Running the product in reversed phase may break the compressor and other parts.
- Attach the power wire securely. Introducing power with a missing N-phase or with a mistaken N-phase will break the unit.
- Make sure the electrical unbalance ratio is no greater than 2%. If it is larger than this, the unit's lifespan will be reduced. If the ratio exceeds 4%, the unit will shut down and an malfunction code will be displayed on the indoor remote controller.
- Never remove thermistor, sensor or etc. when connecting power wiring and transmission wiring.
 If operated with thermistor, sensor or etc. removed, the compressor may be broken down.
- Never connect the power supply in reversed phase.
 The unit can not operate normally in reversed phase.
 If you connect in reversed phase, replace two of the three phases.
- Connect the wire securely using designated wire and fix it with attached clamp without applying external pressure on the terminal parts (terminal for power wiring, terminal for transmission wiring and earth terminal).

7-1 Power circuit, safety device and cable requirements

- A power circuit (see the following table) must be provided for connection of the unit. This circuit must be protected with the required safety devices, i.e. a main switch, a slow blow fuse on each phase and an earth leakage circuit breaker.
- When using residual current operated circuit breakers, be sure to use a high-speed type (0.1 second or less) 200mA rated residual operating current.
- Specifications for local wiring are in compliance with IEC60245.
- Select the power supply cable type and size in accordance with relevant local and national regulations.
- Use copper conductors only.
- Use insulated wire for the power cord.
- Use wire type H05VV when protected pipes are used.
 Use wire type H07RN-F when protected pipes are not used.

	Phase and frequency	Voltage	Minimum circuit amp.	Recommended fuses
<for individual unit>				
RTSQ8PY1	φ 3, 50Hz	380-415V	18.5A	25A
RTSQ10PY1	φ 3, 50Hz	380-415V	21.6A	25A
RTSQ12PY1	φ 3, 50Hz	380-415V	22.7A	25A
RTSQ14PY1	φ 3, 50Hz	380-415V	31.5A	35A
RTSQ16PY1	φ 3, 50Hz	380-415V	31.5A	35A
BTSQ20PY1	φ 3, 50Hz	380-415V	15.2A	20A
<for system>				
RTSYQ10PY1	φ 3, 50Hz	380-415V	21.6A	25A
RTSYQ14PY1	φ 3, 50Hz	380-415V	31.5A	35A
RTSYQ16PY1	φ 3, 50Hz	380-415V	31.5A	35A
RTSYQ20PY1	φ 3, 50Hz	380-415V	41.2A	50A

7-2 Wiring Connection Example for Whole System

(Refer to figure 20)

1. Power supply
2. Main switch
3. Earth leakage circuit breaker
4. Fuse
5. Outdoor unit
6. Function unit
7. Remote controller
8. Indoor unit

Note

- All field wiring is to be procured on site.
- Make sure the weak electric wiring (i.e. for the remote controller, between units, etc.) and the power wiring do not pass near each other, keeping them at least 50 mm apart.
 Proximity may cause electrical interference, malfunctions, and breakage.
- Transmission wiring should be secured as described in "7-4 Transmission Wiring Connection Procedure".
- Be sure to connect the power wiring to the power wiring terminal block and secure it as described in "7-5 Power Wiring Connection Procedure".
- Secure wiring with clamp such as insulation lock ties to avoid contact with piping.
- Shape the wires to prevent the structure such as the EL. COMPO. BOX lid deforming. And close the cover firmly.

7-3 Leading wire Procedure

- The power wiring and ground wiring are passed out from the power wiring hole on the sides, the front (knock hole) or the bottom frame (knock hole).
- The transmission wiring is passed out from the wiring hole (knock hole) on the front of the unit or from a piping hole.

(Refer to figure 21)

- Outdoor unit
- Function unit
- Electric wiring diagram (Rear side of EL.COMPO.BOX lid)
- Power wiring and ground wiring
- Conduit
- Piping outlet
- Transmission wiring
- To Indoor unit and function unit
- Wiring inlet (front)
- Through cover
- Cut off the hatching parts.
- Power wiring and ground wiring
- Inside conduit
- To outdoor unit
- Knock hole
- For transmission wiring
- For power wiring and ground wiring
- Burr

Note 

- Open the knock holes with a hammer or the like.
- After knocking out the holes, we recommend you remove any burrs and paint them using the repair paint to prevent rusting. **(Refer to figure 21)**
- When passing wiring through the knock holes, remove burrs around the knock holes and protect the wiring with conduit or protective tape.
- If small animals might enter the unit, block off any gaps (hatching parts in figure 21) with material (field supply).

7-4 Transmission Wiring Connection Procedure

- Referring to figure 22 connect the transmission wiring between outdoor unit and function unit, outdoor unit and outdoor unit of same system (Only in case multi outdoor unit system), outdoor unit and indoor unit, outdoor unit and outdoor unit of other system.

(Refer to figure 22)

- For single outdoor unit system
- For multi outdoor unit system
- Outdoor unit
- Function unit
- Master outdoor unit A (*)
- Slave outdoor unit B (*)
- To outdoor unit in other refrigerant system
- Indoor unit
- Use 2-core cable (with no polarity).
- Never connect power wiring.

(*) In the case of the multi outdoor unit system, the outdoor unit connecting the transmission wiring to the indoor unit (outdoor unit A in figure 22) is the master and the other outdoor unit is the slave. Operate the control PCB (A1P) of the master for commissioning at the time of installation or local settings at the time of servicing.

Note 

- Do not connect the power wiring to terminals for the transmission wiring. Doing so would destroy the entire system.
- When connecting wires to the terminal block on the PC-board, too much heat or tightening could damage the PC-board. Attach with care. See the table below for the tightening torque of the transmission wiring terminals.

Screw size	Tightening torque (N · m)
M3.5 (A1P)	0.80 - 0.96

- All transmission wiring should use sheathed vinyl cord 0.75-1.25 mm² or cable (duplex).
- Transmission wiring should be done within the following limitations.

If they are exceeded, transmission problems may occur.

Between outdoor unit and indoor unit
Between outdoor unit and outdoor unit of other systems

Max. wiring length :1,000 m
Max. total wiring length :2,000 m
Max. no. of branches :16

[Note]

No branch is allowed after branch **(See figure 23)**

Max. no. of outdoor units of other system that can be connected

: 10

Between outdoor unit and function unit

Between outdoor unit and outdoor unit of same system

Max.wiring length :30 m

(Refer to figure 23)

- Branch
- Branch after branch

- The transmission wiring inside the EL.COMPO.BOX should be secured using the clamp (1) as shown in figure 24.

(Refer to figure 24)

- Outdoor unit
- Function unit
- Inside EL.COMPO.BOX
- Fix two portions in the EL.COMPO.BOX with the included clamp (1).
- Fix a single portion in the EL.COMPO.BOX with the included clamp (1).
- Never connect power wiring.

- Outside the units, the transmission wiring must be finished simultaneously with the local refrigerant piping, and wound with tape (field supply) as shown in figure 25.

(Refer to figure 25)

- Gas pipe
- Liquid pipe
- Transmission wiring
- Insulation material
- Finishing tape

- Wiring to other systems should be connected to terminals F1 and F2 (TO OUT/D UNIT) on the PC-board of the unit. Connecting the wires to the Q1, Q2 (TO MULTI UNIT) terminals results in malfunction.

7-5 Power Wiring Connection Procedure

- Be sure to connect the power supply wiring to the power supply terminal block and hold it in place using the included clamp (1) as shown in the figure 26.
- The ground wiring should be bound to the power wiring using the included clamp (1) to prevent outside force from being applied to the terminal.

(Refer to figure 26)

- Power supply (3N ~ 50 Hz, 380 - 415 V)
- Earth leakage circuit breaker
- Fuse
- Ground wiring
- Outdoor unit
- Function unit
- Power supply terminal block
- Ground terminal
- Clamp (1) (accessories)
- Power wiring and ground wiring (to power supply)
- Attach the insulating sleeve.
- Lay and connect from the upper side

 **Warning**

Be sure to install an earth leakage circuit breaker.

The installation of an earth leakage circuit breaker is a must in order to prevent electric shock or fire prevention.

Note 

- For wiring, use the designated power wire and connect firmly, then secure to prevent outside pressure being exerted on the terminal board.
- Be sure to use crimp-style terminal with insulating sleeves for connections. (See the figure below.)

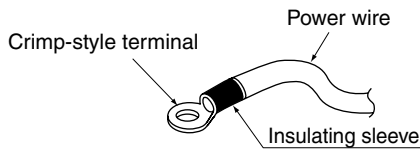

- When pulling the ground wire out, wire it so that it comes through the cut out section of the cup washer. (See the figure below.) An improper ground connection may prevent a good ground from being achieved.

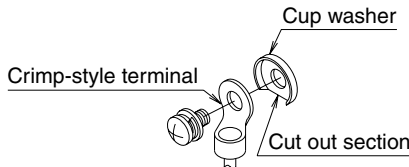

- When two wires are connected to a single terminal, connect them so that the rear sides of the crimp contacts face each other. Also, make sure the thinner wire is on top, securing the two wires simultaneously to the resin hook using the included clamp (1).

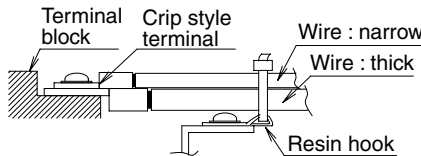

- Use an appropriate screwdriver for tightening the terminal screws. A screwdriver with a small head will strip the head and make proper tightening impossible. Over-tightening the terminal screws may break them. See the following table for the tightening torque of the terminal screws.

Screw size	Tightening torque (N·m)
M8 (Power and ground terminals of outdoor unit)	5.5 - 7.3
M5 (Power and ground terminals of outdoor unit)	2.0 - 3.0

7-6 Procedure for Wiring Inside Units

- Referring to figure 27 and 28, secure and wire the power and transmission wiring using the included clamp (1), (2), and (3).
- Wire so that the ground wiring does not come into contact with the compressor lead wiring. If they touch, this may have an adverse effect on other devices.
- Make sure all wiring do not contact to the pipes (hatching parts in the figure 27 and 28).
- The transmission wiring must be at least 50 mm away from the power wiring.

(Refer to figure 27)

1. For RTSQ8 to RTSQ12PY1
2. For RTSQ14 and RTSQ16PY1
3. In the case of pulling in the power wire and ground wire from the left-hand side.
4. Conduit
5. Stay
6. Fix to the stay with the included clamp (3).
7. Power wiring
8. Ground wiring
9. Transmission wiring
10. In the case of pulling in the power wire and ground wire from the right-hand side.
11. In the case of pulling in the transmission wire from the piping outlet.
12. In the case of pulling in the power wiring and ground wiring from the front side.

13. Separate at least 50 mm.
14. In the case of pulling in the transmission wiring from the front side.
15. Fix to the rear side of the side plate with the included clamp (2).
16. Support
17. Fix to the rear side of the support with the included clamp (1).
18. Fix to the rear side of the support with the included clamp (2).
19. Perform wiring carefully so that the sound blanket of the compressor will not be dismantled.

(Refer to figure 28)

1. For BTSQ20PY1
2. Power wiring
3. Ground wiring
4. Transmission wiring
5. In the case of pulling in the power wiring and ground wiring from the left-hand side.
6. In the case of pulling in the power wiring and ground wiring from the right-hand side.
7. Pull in the transmission wiring from the piping outlet.
8. Perform wiring (on both right- and left-hand sides) so that the sealing materials on the bottom of the EL.COMPO.BOX will not be deformed.
9. Perform wiring carefully so that the sound blanket of the compressor will not be dismantled.

Note 

- After wiring work is completed, check to make sure there are no loose connections among the electrical parts in the EL.COMPO.BOX.

8. TESTS AND INSULATION WORK

Note 

- Always use nitrogen gas for the airtightness test.
- Absolutely do not open the shutoff valve until the main power circuit insulation measurement (refer to 8-3) has been completed. (measuring after the shutoff valve is opened will cause the insulation value to drop.)

8-1 Air tight test and vacuum drying

- After finished piping work, carry out air tight test and vacuum drying.

Note 

- Be sure to conduct the airtight test and vacuum drying through the service port of the shutoff valves of the liquid pipe and gas pipe, and shutoff valve of the equalizer pipe (for the multi outdoor unit system only) of the outdoor unit and the service port of the liquid pipe and gas pipe of the function unit.

See the [R410A] Label attached to the front plate of the each unit for details on the location of the service port (see figure at right).

- See [Shutoff valve operation procedure] in "9-1 Before working" for details on handling the shutoff valve.
- Pay attention to refrigerant leakage when connecting a charge hose to the refrigerant charge port. The refrigerant charge port is connected to the piping inside the product, and the piping is charged with refrigerant before shipping from the factory.

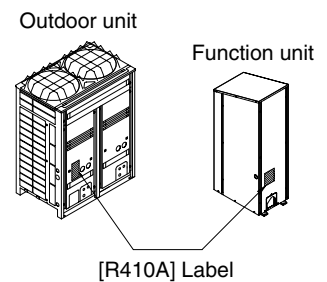

<Needed tools>

Gauge manifold Charge hose valve	<ul style="list-style-type: none"> • To prevent entry of any impurities and insure sufficient pressure resistance, always use the special tools dedicated for R410A. • Use charge hose that have pushing stick for connecting to service port of shutoff valves or refrigerant charge port.
Vacuum pump	<ul style="list-style-type: none"> • Take care the pump oil never flow backward into the refrigerant pipe during the pump stops. • The vacuum pump for vacuum drying should be able to lower the pressure to -100.7kPa (5 Torr -755mm Hg).

<The system for air tight test and vacuum drying>

- Referring to figure 29, connect an nitrogen tank, refrigerant tank, and a vacuum pump to the outdoor unit and function unit. The refrigerant tank and the charge hose connection to refrigerant charge port or the valve A in figure 29 are needed in “9. ADDITIONAL REFRIGERANT CHARGE AND CHECK OPERATION”.

(Refer to figure 29)

- Gauge manifold
- Nitrogen
- Measuring device
- R410A tank (with siphon)
- Vacuum pump
- Charge hose
- Refrigerant charge port
- Liquid pipe shutoff valve
- Gas pipe shutoff valve
- Equalizer pipe shutoff valve
- Outdoor unit A
- Outdoor unit B (for multi outdoor unit system)
- Function unit
- Liquid pipe service port
- Gas pipe service port
- Valve A
- Valve C
- Valve B
- The equalizer piping requires an airtight test and vacuum drying only for the multi outdoor unit system.
- To indoor unit
- Local piping
- Airflow
- Shutoff valve
- Service port

<Air tight test>

Pressurize the liquid pipe, gas pipe and the equalizer pipe (for the multi outdoor unit system only) from the each shutoff valve service ports of outdoor unit and the service ports of function unit to 4.0 MPa (40 bar) (do not pressurize more than 4.0 MPa (40 bar)). If the pressure does not drop within 24 hours, the system passes the test.

If there is a pressure drop, check for leaks, make repairs and perform the airtight test again.

<Vacuum drying>

Evacuate the liquid pipe, gas pipe and the equalizer pipe (for the multi outdoor unit system only) from the each shutoff valve service ports of outdoor unit and the service ports of function unit by using a vacuum pump for more than 2 hours and bring the system to -100.7 kPa or less. After keeping the system under that condition for more than 1 hour, check if the vacuum gauge rises or not. If it rises, the system may either contain moisture inside or have leaks.

Note

[Airtight test and vacuum drying while in Evacuation mode setting]

When all the electrical work on the system including the indoor unit is finished and it is safe to supply power to the system, turn ON the entire system and set the Evacuation mode setting (service mode) through the PCB (A1P) of the outdoor unit. All the connection piping and indoor unit excluding the equalizer piping can be airtight tested and vacuum dried through the liquid pipe service port of the function unit. Furthermore, refrigerant charging through the liquid piping is possible while the system is not in operation. Refrigerant charging is not possible while the system is in operation.

For the details of the Evacuation mode setting, refer to the [Service precautions] label (below) on the EL.COMPO.BOX lid of the outdoor unit.

If moisture might enter the piping, follow belows.

(I.e., if doing work during the rainy season, if the actual work takes long enough that condensation may form on the inside of the pipes, if rain might enter the pipes during work, etc.)

- After performing the vacuum drying for two hours, pressurize to 0.05 MPa (i.e., vacuum breakdown) with nitrogen gas, then depressurize down to -100.7 kPa for an hour using the vacuum pump (vacuum drying).

- If the pressure does not reach -100.7 kPa even after depressurizing for at least two hours, repeat the vacuum breakdown - vacuum drying process.
- After then, maintain the vacuum for an hour and make sure the pressure does not rise by monitoring with a vacuum gauge.



8-2 Pipe insulation

- Insulation of pipes should be done after performing “8-1 Air tight test and vacuum drying”.
- Always insulate the liquid pipe, gas pipe and equalizer pipe (the piping between the outdoor units in the case of the multi outdoor unit system) and these pipe connections. Failing to insulate the pipes may cause leaking or burns. And be sure to use the insulation which can withstand such temperatures of 120°C or more for the gas piping because the high pressure gas follows in these pipings.
- Thermal insulate the liquid pipe and gas pipe of the function unit up to the point immediately before the piping support in the function unit. (Refer to figure 30)
- If there is a possibility that condensation on the shutoff valve might drip down into the indoor unit through gaps in the insulation and piping because the function unit is located higher than the indoor unit, etc., this must be prevented by caulking the connections, etc. (Refer to figure 30)

(Refer to figure 30)

- Piping support
 - Gas pipe (to outdoor unit)
 - Liquid pipe (to outdoor unit)
 - Thermal insulator end (4 points)
 - Perform caulking processing.
 - Liquid pipe (to indoor unit)
 - Gas pipe (to indoor unit)
- Reinforce the insulation on the refrigerant piping according to the installation environment. Condensation might form on the surface of the insulation. Refer to the below.
 - Ambient temperature : 30°C, humidity : 75% to 80% RH : min. thickness : 15mm.
 - If the ambient temperature exceeds 30°C and the humidity 80% RH, then the min. thickness is 20mm. See the Engineering data book for detail.
 - The piping lead-out hole lid should be attached after opening a knock hole. If small animals and the like might enter the unit through the piping lead-out hole, close the hole with blocking material (procured on site) after completion of “9. ADDITIONAL REFRIGERANT CHARGE AND CHECK OPERATION”. (Refer to figure 31)

(Refer to figure 31)

- Piping lead-out hole lid
- Open a knock hole at “”.
- Block “”.

Note

- After knocking out the holes, we recommend you remove burrs in the knock holes (See figure 31) and paint the edges and areas around the edges using the repair paint.

8-3 Checking of device and installation conditions

Be sure to check the followings.

For those doing electrical work

- Make sure there is no faulty transmission wiring or loosening of a nut. See “7-4 Transmission Wiring Connection Procedure”.
- Make sure there is no faulty power wiring or loosening of a nut. See “7-5 Power Wiring Connection Procedure”.
- Has the insulation of the main power circuit deteriorated? Measure the insulation and check the insulation is above regular value in accordance with relevant local and national regulations.

⊘ Prohibition

Do not use a insulation resistance tester to light electric circuits (e.g., transmission wire terminals between outdoor and indoor units).

For those doing pipe work

1. Make sure piping size is correct.
See "6-1 Selection of piping material and Refrigerant branching kit".
2. Make sure insulation work is done.
See "8-2 Pipe insulation".
3. Make sure there is no faulty refrigerant piping.
See "6. REFRIGERANT PIPING".

9. ADDITIONAL REFRIGERANT CHARGE AND CHECK OPERATION

The outdoor unit is charged with refrigerant when shipped from the factory, but depending on the size and length of the piping when installed, it may require additional charging.

For charging the additional refrigerant, follow the procedure in this chapter.

And then carry out the check operation.

Warning Electric Shock Warning

- Make sure to close the EL. COMPO. BOX (both outdoor unit and function unit) lid before turning on the power.
- Perform the setting on the PC-board (A1P) of the outdoor unit and check the LED display after the power is on via the inspection door which is in the EL. COMPO. BOX lid. (Refer to figure 32)
- Use an insulated rod to operate the push buttons via the EL. COMPO. BOX's inspection door. (Refer to figure 32)
There is a risk of electric shock if you touch any live parts, since this operation must be performed with the power on.

(Refer to figure 32)

1. Inspection door
2. EL. COMPO. BOX
3. [Service precautions] label (upper)
4. [Service precautions] label (lower)
5. Outdoor unit
6. Function unit
7. EL. COMPO. BOX lid
8. LED (H1~8P)
9. Push button (BS1~5)
10. Lift the protruding part to open the inspection door.

Caution

- Make sure to use the protect tool (protective grooves and goggles) when charging the refrigerant.
- Do not perform the refrigerant charging operation under working for the indoor unit.
- When opening the front panel, make sure to take caution to the fan rotation during the working.
After the outdoor unit stops operating, the fan may keep rotation for a while.
- Due to a danger of liquid hammer, the refrigerant must not be charged over the allowable maximum amount when charging the refrigerant.

Note

- If operation is performed within 12 minutes after the indoor, outdoor and function units are turned on, H2P will be lit on and the compressor will not operate.
- In order to ensure uniform refrigerant distribution, it may take up to around 10 minutes for the compressor to start up after the unit starting operating. This is not a malfunction.
- Be careful when connecting the charge hose. The refrigerant charge port is connected to the piping inside the unit.
When the unit is shipped from the factory, the unit's internal piping is already charged with refrigerant.
- When done or when pausing the refrigerant charging operation, close the valve of the refrigerant tank immediately.
The refrigerant charge port of this product have electric expansion valve.
The valve will be closed at end of refrigerant charging. However the valve will be opened on operation after refrigerant charging (check operation, normal operation, etc.).
If the tank is left with the valve open, the amount of refrigerant which is properly charged may be off the point.



- See [Shutoff valve operation procedure] in chapter 9-1 for details on how to handle shutoff valves.
- After adding the refrigerant, make sure to close the lid of the refrigerant charging port.
The tightening torque for the lid is 11.5 to 13.9 Nm.
- Make sure to perform the check operation after installation. Otherwise, the malfunction code "U3" will be displayed and normal operation cannot be performed.
And the failure of "Check of miswiring" may also cause abnormal operation. Performance may drop due to the failure of "Judgment of piping length".
- Check operation must be performed for each refrigerant piping system.
Checking is impossible if plural systems are being done at once.
- The individual problems of indoor units can not be checked.
About these problems check by test run after the check operation is completed. (See chapter 10)
- The check operation cannot be performed in recovery or other service modes.

9-1 Before working

[About the refrigerant tank]

Check whether the tank has a siphon pipe before charging and place the tank so that the refrigerant is charged in liquid form.

(See the figure below.)

With siphon pipe	
	Stand the tank upright and charge. (The siphon pipe goes all the way inside, so the tank does not need to be put upside-down charge in liquid form.)
Other tanks	
	Stand the tank upside-down and charge.

Note

- Always use the proper refrigerant (R410A). If charged with the refrigerant containing an improper material, it may cause an explosion or accident.
- R410A is a mixed refrigerant, so charging it as a gas will cause the refrigerant composition to change, which may prevent normal operation.

[Shutoff valve operation procedure]

When operating the shutoff valve, follow the procedure instructed below.

Note

- Do not open the shutoff valve until "8-3 Checking of device and installation conditions" are completed. If the shutoff valve is left open without turning on the power, it may cause refrigerant to buildup in the compressor, leading insulation degradation.
- Be sure to use the correct tools.
The shutoff valve is not a back-seat type. If forced it to open, it might break the valve body. (Refer to figure 33)
- When using a service port, use the charge hose.
- After tightening the cap, make sure no refrigerant gas is leaking.

Tightening torque

The sizes of the shutoff valves on each model and the tightening torque for each size are listed in the table below.

<Size of Shutoff Valve>

	8HP type	10HP type	12HP type	14HP type	16HP type
Liquid pipe shutoff valve	$\phi 9.5$ The 12HP type corresponds to the 12.7-diameter onsite piping using the accessory pipe.			$\phi 12.7$	
Gas shutoff valve	$\phi 19.1$ The 8 · 10HP type corresponds to the 22.2-diameter onsite piping using the accessory pipe. The 12-16 HP type corresponds to the 28.6-diameter onsite piping using the accessory pipe.				
Equaliger pipe shutoff valve	$\phi 19.1$		$\phi 19.1$		

<Tightening torque>

Shutoff valve size	Tightening torque N·m (Turn clockwise to close)			
	Shaft (valve body)	Hexagonal wrench	Cap (valve lid)	Service port
$\phi 9.5$	5.4 - 6.6	Hexagonal wrench 4 mm	13.5 - 16.5	11.5 - 13.9
$\phi 12.7$	8.1 - 9.9		18.0 - 22.0	
$\phi 19.1$	27.0 - 33.0	Hexagonal wrench 8 mm	22.5 - 27.5	

(Refer to figure 33)

1. Service port
2. Cap
3. Hex holes
4. Shaft (valve body)
5. Seal section

To open

1. Remove the cap and turn the shaft counterclockwise with the hexagon wrench (JISB4648).
2. Turn it until the shaft stops.
3. Make sure to tighten the cap securely.
(For the tightening torque, refer to the item <Tightening Torque>.)

To close

1. Remove the cap and turn the shaft clockwise with the hexagon wrench (JISB4648).
2. Securely tighten the valve until the shaft contacts the main body seal.
3. Make sure to tighten the cap securely.
(For the tightening torque, refer to the item <Tightening Torque>.)

[How to Check How Many Units are Connected]

It is possible to find out how many indoor or outdoor (function) unit in the system are turned on by operating the push button on the PC-board (A1P) of outdoor unit (In case of multi system master unit).

Follow the procedure below to check how many indoor or outdoor units are turned on.

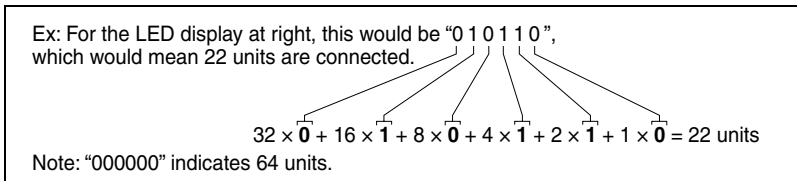
(LED display: ● ...OFF ☀ ...ON ⚡ ...Blinking * ...Uncertain)	LED display						
	H1P	H2P	H3P	H4P	H5P	H6P	H7P
(1) Press the MODE button (BS1) once at Setting Mode 1 (H1P : off), and set the MONITOR MODE (H1P : Blinking).	⚡	●	●	●	●	●	●
(2) Press the SET button (BS2) the number of times until the LED display matches that at right.	For checking the number of outdoor units (*1) : eight times	⚡	●	●	☀	●	●
	For checking the number of indoor units : five times	⚡	●	●	●	☀	☀
(3) Press the RETURN button (BS3) and read the number of units from the display of H2P through H7P. [Reading Method] The display of H2P through H7P should be read as a binary number, with ⚡ standing for "1" and ● standing for "0".	⚡	*	*	*	*	*	*
Ex: For the LED display at right, this would be "0 1 0 1 1 0", which would mean 22 units are connected. 	⚡	●	⚡	●	⚡	⚡	●
(4) Press the MODE button (BS1) once. This returns to Setting Mode 1 (H1P : OFF, default).	●	●	☀	●	●	●	●

(*5) The number include the function unit.

Note

Press the "MODE button" (BS1) if you get confused while operating. This returns to **Setting Mode 1** (H1P : OFF, default).

9-2 Procedure of Additional Refrigerant charging

- Make sure the following works are complete in accordance with the installation manual.
 - Piping work
 - Wiring work
 - Air tight test and Vacuum drying
 - Installation work for indoor unit
- Calculate the "additional charging amount" using "How to calculate the additional refrigerant to be charged" in "6-5 Example of connection".
- Open the valve B (See the figure 34. The valve A,C and the shut-off valves of outdoor unit must be left closed), and charge the refrigerant of the "additional charging amount" from the liquid pipe service port of function unit.
- Close valve B when the refrigerant is charged as much as possible. (Refer to figure 34)
- Perform the automatic refrigerant charging operation according to the [Automatic refrigerant charging operation procedure] and fill the remaining quantity of refrigerant.
Go to step 6 if the additional quantity of refrigerant to be replenished is known and no automatic charging operation is performed or the contraction of working hours is required.
- If the additional quantity of refrigerant was not replenished in step 5 (automatic refrigerant charging operation), perform the additional refrigerant charging operation in service mode and replenish the refrigerant through the refrigerant charging port.
Refer to the "Additional refrigerant charging method" described in the [Service precautions] label (below) on the EL.COMPO.BOX lid of the outdoor unit for the additional refrigerant charging operation in service mode.
- After completing the additional refrigerant charging, record the charging amount on the accessory "REQUEST FOR THE INDICATION" label (Installation records) and adhere it to the back side of the front panel. Also, record the factory charged refrigerant amount, additional refrigerant amount in the field and total refrigerant amount of the system to "ADDITIONAL REF. CHARGE" label and adhere in the proximity of the refrigerant charge port. About "ADDITIONAL REF. CHARGE" label, refer to [Important information regarding the refrigerant used] in "1-2 Special notice of product".



(Refer to figure 34)

- Measuring device
- R410A tank (with siphon)
- Charge hose
- Refrigerant charge port
- Liquid pipe shutoff valve
- Gas shutoff valve
- Equalizer pipe shutoff valve
- Outdoor unit A
- Outdoor unit B (for multi outdoor unit)
- Function unit
- Liquid pipe service port
- Gas pipe service port
- Valve A
- Valve C
- Valve B
- To indoor unit
- Local piping
- Flow of refrigerant
- Shutoff valve
- Service port

[Automatic refrigerant charging operation procedure]

Note

- For performing the automatic refrigerant charging operation, the push button on the PC-board (A1) of outdoor unit are used. (See figure 32.)
And the refrigerant are charged from the refrigerant charge port via the valve A. (See figure 34.) For operating the push button and opening or closing the valves, follow the procedure.
- During Automatic refrigerant charging operation, the system will select charging mode (cooling mode or heating mode) by the temperature condition as follows.

Outdoor temp. : 0°C DB ~ 43°C DB]  Cooling mode
 Indoor temp. : 10°C DB ~ 32°C DB]  Heating mode
 Less than above range  Heating mode

When charging in cooling mode, the system will stop operation when the required amount of refrigerant is charged.

During charging in heating mode, a person must manually close valve A and stop operation.

Beforehand, check the remaining refrigerant that is needed to charge based on the "additional charging amount" in step 2 and the charged amount in step 3.

- The refrigerant will be charged about 30kg in one hour at outdoor temp. 30°C DB (about 12kg at outdoor temp. 0°C DB). (The charging speed of refrigerant may increase depending on the quantity of remaining refrigerant in the tank or outdoor temperature.)
- During Automatic refrigerant charging operation, you can stop the operation forcedly by pushing MODE button (BS1).
- The marks of LED mean as follows.
 ● : OFF ☀ : ON ⚡ : Blinking * : OFF, ON or Brinking

- (1) Open the shutoff valves of the liquid pipe and gas pipe, and shutoff valve of equalizer pipe (in the case of the multi outdoor unit system). (The valve A to C must be closed. See figure 34.)
- (2) • Close the EL. COMPO. BOX lid and all front panel except on the EL. COMPO. BOX side. (*1) And turn the power to the outdoor unit, function unit and all connected indoor units. (*2)
 • After H2P stop blinking (about 12 minutes after turning on the power), check H2P is OFF.
 If H2P is ON, check the malfunction code in the remote controller of indoor unit and correct the malfunction in accordance with [Remote controller display malfunction code] in chapter 9-3.

Note 

All operation is done through outdoor unit (in case of multi outdoor unit system, master unit)
 Distinguish the master and slave of the multi outdoor unit system through the state of the H8P (MULTI) LED indicators.

☀ (On)	Master
⚡ (Blinking) or ● (OFF)	Slave

Furthermore, the master and slave can be distinguished by checking whether the transmission wire to the indoor unit is connected or not.

Transmission wire is connected.....	Master
Transmission wire is not connected.....	Slave

- (3) Check the LED. And push the MODE button (BS1) once if the LED displays is not as below.

H1P	H2P	H3P	H4P	H5P	H6P	H7P
●	●	☀	●	●	●	●

- (4) Push the TEST button (BS4) once. (The LED displays will change as below.)

H1P	H2P	H3P	H4P	H5P	H6P	H7P
☀	☀	☀	☀	☀	☀	☀

- (5) Hold the TEST button (BS4) down for 5 seconds or more. (The LED displays will change as below and fan of outdoor unit will start rotation.)

H1P	H2P	H3P	H4P	H5P	H6P	H7P
●	⚡	●	●	●	*	*

- (6) When the compressor start working and the LED displays change any state in below (*3), go to "In case of cooling mode" or "In case of heating mode" in accordance with the LED displays.

H1P	H2P	H3P	H4P	H5P	H6P	H7P
⚡	⚡	⚡	●	☀	●	☀
⚡	⚡	●	●	☀	●	☀

➡ Go to "In case of cooling mode"
 ➡ Go to "In case of heating mode"

— In case of cooling mode —

- (7) Push the TEST button (BS4) once within 5 minutes after procedure (6) (*4) and close the all front panels (*5).
 After that, open the valve A immediately (See figure 34) (*6) and watch the remote controller display of indoor unit.
- (8) If the remote controller display shows "PE" code (*7), ready to close the valve A.
 And go to procedure (9).
 If the remote controller display shows other code, close the valve A immediately and refer to [Remote controller cooling mode malfunction code]

 **Beware the fan running when open the front panel.**
The fan may continue rotation after the system stop the operation.

- (9) When the compressor stop working (the fan may continue rotation.), close the valve A immediately (*8).
 And check the LED displays are as below and the remote controller display shows "P9" code.

H1P	H2P	H3P	H4P	H5P	H6P	H7P
☀	⚡	⚡	☀	☀	☀	☀

After checking, push the MODE button (BS1) once and the charging is complete.

— In case of heating mode —

- (7) Push the TEST button (BS4) once within 5 minutes after procedure (6) (*4) and close the all front panels.
 After that, open the valve A immediately (See figure 34) (*6) and check the charged amount by measuring device.
 During operation, if the remote controller display shows "P2" or "P8" code, close the valve A immediately and refer to [Remote controller heating mode malfunction code].

 **Beware the fan running when open the front panel.**
The fan may continue rotation after the system stop the operation.

- (8) When the required amount of refrigerant is charged, close the valve A (See figure 34) (*8) and push the RETURN button (BS3) once. And then go to procedure (9).
- (9) Push the MODE button (BS1) once, and the charging is complete.

Notes (*1)~(*9)

- (*1) Lead the refrigerant charge hose etc from the pipe intake.
 All front panels must be closed at the procedure (7).
- (*2) • If you perform the refrigerant charging operation within the refrigerant system that have the power off unit, the operation cannot finish properly.
 Check the number of outdoor and indoor units that is powered. For checking, see [How to check how many units are connected] in chapter 9-1.
 • To energize the crankcase heater, make sure to turn on for 6 hours before starting operation.
- (*3) It takes about 2~10 minutes for getting stability of refrigerant state.
 If the additional refrigerant is little and operation is started before getting stability, the system can not judge the charging amount precisely and it cause over charge.
- (*4) If the TEST button (BS4) is not pushed within 5 minutes, "P2" code will displayed in the remote controller. In this case, refer [Remote controller cooling (or heating) mode malfunction code].
- (*5) If the front panel is opened during the operation, the system cannot operate properly.
- (*6) If you leave the system without connecting the refrigerant tank or opening the valve A for 30 minutes or more, the system stop operation and "P2" code are displayed in remote controller. In this case, refer [Remote controller cooling (or heating) mode malfunction code].
- (*7) Depending on the situation of operation such as the charging amount is little, the "PE" code may not be displayed and the "P9" code may be displayed.
- (*8) Always close the valve A and take the tank off.
 The refrigerant charge port of this unit have electric expansion valve and the valve are closed when charging is finished. However, the valve will opened when ather operation (Check operation, normal operation, etc.). If you leave the tank connected, the refrigerant will charged and it cause over charge.

[Remote controller cooling mode malfunction code]

Code	The work contents
PE	Charging is almost finished. Ready to close the valve A.
PA PH	The refrigerant tank is empty. Close the valve A and replace empty tank to the new tank. After changing the tank, open the valve A again. ⚠ Beware the fan running. The outdoor unit does not stop operation.
P8	Close the valve A immediately, and restart the operation from procedure (3).
P2	Operation is interrupted. Close the valve A immediately and check the below items. <ul style="list-style-type: none"> • Check if the shutoff valves of liquid pipe and gas pipe, and shutoff valve of equalizer pipe (in the case of the outdoor unit multi system) is opened. • Check the refrigerant tank is connected and the valve A was opened. • Check if the air inlet and outlet of the indoor unit are not closed by an obstruction.
	After correcting the abnormality, restart the operation from procedure (3).
*	Operation is stopped abnormally. Close the valve A immediately. Confirm the malfunction code and correct the abnormality following the [Remote controller displays malfunction code] in chapter 9-2.
P9	Charging is finished. Close the valve A and take the refrigerant tank off.

[Remote controller heating mode malfunction code]

Code	The work contents
P8	Close the valve A immediately and push the TEST button (BS4) once. And restart from procedure (7) of "In case of heating mode".
P2	Operation is interrupted. Close the valve A immediately and check the below items. <ul style="list-style-type: none"> • Check if the shutoff valves of liquid pipe and gas pipe, and shutoff valve of equalizer pipe (in the case of the outdoor unit multi system) is opened. • Check the refrigerant tank is connected and the valve A was opened. • Check if the air inlet and outlet of the indoor unit are not closed by an obstruction.
	After correcting the abnormality, restart the operation from procedure (3).

9-3 Procedure of check operation

- Check operation perform the following work. Do the check operation following below.
Otherwise, malfunction code "U3" will be displayed in the remote controller and normal operation can not be carried out.
 - Check of shutoff valve opening
 - Check of miswiring
 - Judgment of piping length
 - Check of refrigerant overcharge (*)
- * Over charging is judged only when the automatic charging operation in cooling mode is not performed.

Note

- Check operation can not carried out at outdoor temp. less than -5°C. Perform the check operation at day or time that outdoor temp. is -5°C or more.
- For interrupting the check operation, push RETURN button (BS3).

[Check Operation Procedure]

- (1) Close the EL. COMPO. BOX lid and all front panels except as the side of the EL. COMPO. BOX and turn on the power to the outdoor unit, function unit and all connected indoor units. (Be sure to turn the power on at least 6 hours before operation in order to have power running to the crank case heater.)

- (2) Make the onsite settings as needed using the push button (BS1-BS5) on the outdoor unit PC-board (A1P) with the power on. (See "10. ONSITE SETTINGS")
- (3) Perform the check operation following the Check Operation Method of the [Service Precautions] label (lower) on the EL. COMPO. BOX lid (see figure 32). The system operation for about 45~60 minutes and automatically stops the check operation. If the malfunction code is not displayed in the remote controller after the system stop, check operation is completed. Normal operation will be possible after 5 minutes. If the malfunction code is displayed in the remote controller, correct the malfunction following [Remote controller displays malfunction code] and perform the check operation again.

[Remote controller displays malfunction code]

Malfunction code	Installation error	Remedial action
E3, E4 F3, F6 UF	The shutoff valve of the outdoor unit is left closed.	Open the shutoff valve.
U1	The phases of the power to the outdoor unit is reversed.	Exchange two of the three phases (L1, L2, L3) to make a proper connection.
U1 U4 LC	No power is supplied to an outdoor, BS or indoor unit (including phase interruption).	Make sure the power source wire is properly connected to the outdoor, BS or indoor unit and revise if necessary.
UF	There is conflict on the connection of transmission wiring in the system.	Check if the refrigerant piping line and the transmission wiring are consistent with each other.
E3 F6 UF	Refrigerant overcharge.	Recalculate the additional amount refrigerant from the piping length and correct the refrigerant charge level by recovering any excessive refrigerant with a refrigerant recovery machine.
E4 F3	Insufficient refrigerant.	<ul style="list-style-type: none"> • Check if the additional refrigerant charge has been finished correctly. • Recalculate the additional amount refrigerant from the piping length and add the adequate amount.
U7, U4 UF, UH	Field wiring is connected to "TO MULTI UNIT (Q1,Q2)" terminal on the outdoor unit PC-board (A1P) when the system is one outdoor system.	Remove the line from the "TO MULTI UNIT (Q1, Q2)" terminal.

Note

If any malfunction codes other than the above are displayed, check the service manual for how to respond.

10. ONSITE SETTINGS

Use the push button switches (BS1 through BS5) on the outdoor unit PC-board (A1P) to make the necessary onsite settings. See the "Service Precautions" label (upper) on the EL. CONPO. BOX lid for details on the positions and operating method of the push button switches and on the onsite setting. (see figure 32)
Make sure to record the setting on the accessory "REQUEST FOR THE INDICATION" label.

⚠ Warning ⚡ Electric Shock Warning

Use an insulated rod to operate the push buttons via the inspection door of EL. COMPO. BOX lid.

There is a risk of electric shock if you touch any live parts, since this operation must be performed with the power on.

11. TEST RUN

11-1 Before test run

- Make sure the following works are completed in accordance with the installation manual.
 - Piping work
 - Wiring work
 - Air tight test and vacuum drying
 - Additional refrigerant charge
 - Check operation
- Check that all work for the BS, indoor unit are finished and there are no danger to operate.

11-2 Test Run

After all works are completed, operate the unit normally and check the following.

- (1) Make sure the indoor and outdoor units are operating normally.
- (2) Operate each indoor unit one by one and make sure the corresponding outdoor unit is also operating.
- (3) Check to see if cold (or hot) air is coming out from the indoor unit.
- (4) Push the fan direction and strength buttons on the remote controller to see if they operate properly.

Note

- Heating is not possible if the outdoor temperature is 24°C or higher. Refer to the Operation manual.
- If a knocking sound can be heard in the liquid compression of the compressor, stop the unit immediately and then energize the crank case heater for a sufficient length of time before restarting the operation.
- Once stopping, the compressor will not restart in about 5 minutes even if the On/Off button of the remote controller is pushed.
- When the system operation is stopped by the remote controller, the outdoor units may continue operating for further 5 minutes at maximum.
- The outdoor unit fan may rotate at low speeds if the Night-time low noise setting or the External low noise level setting is made, but this is not a malfunction.
- If the check operation was not performed at first installation, the malfunction code "U3" will be displayed in the remote controller. Perform the check operation following "9-3 Procedure of Check Operation".

11-3 Checks After Test Run

Perform the following checks after the test run is complete.

- Record the contents of field setting.
 - Record them on the accessory "REQUEST FOR THE INDICATION" label.
 - And attach the label on the back side of the front panel.
- Record the installation date.
 - Record the installation date on the accessory "REQUEST FOR THE INDICATION" label in accordance with the IEC60335-2-40.
 - And attach the label on the back side of the front panel.

Note

After the test run, when handing the unit over to the customer, make sure the EL.COMPO.BOX lid, the inspection door, and the unit casing are all attached.

12. CAUTION FOR REFRIGERANT LEAKS

(Points to note in connection with refrigerant leaks)

Introduction

The installer and system specialist shall secure safety against leakage according to local regulations or standards. The following standards may be applicable if local regulations are not available. The VRV System, like other air conditioning systems, uses R410A as refrigerant. R410A itself is an entirely safe non-toxic, non-combustible refrigerant. Nevertheless care must be taken to ensure that air conditioning facilities are installed in a room which is sufficiently large. This assures that the maximum concentration level of refrigerant gas is not exceeded, in the unlikely event of major leak in the system and this in accordance to the local applicable regulations and standards.

Maximum concentration level

The maximum charge of refrigerant and the calculation of the maximum concentration of refrigerant is directly related to the humanly occupied space in to which it could leak.

The unit of measurement of the concentration is kg/m^3 (the weight in kg of the refrigerant gas in 1m^3 volume of the occupied space).

Compliance to the local applicable regulations and standards for the maximum allowable concentration level is required.

In Australia the maximum allowed concentration level of refrigerant to a humanly space is limited to 0.35kg/m^3 for R407C and 0.44kg/m^3 for R410A.

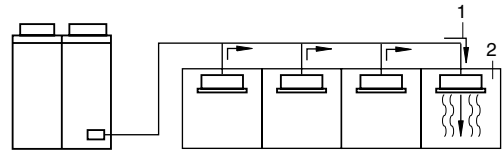

1. direction of the refrigerant flow
2. room where refrigerant leak has occurred (outflow of all the refrigerant from the system)

Pay a special attention to the place, such as a basement, etc. where refrigerant can stay, since refrigerant is heavier than air.

Procedure for checking maximum concentration

Check the maximum concentration level in accordance with steps 1 to 4 below and take whatever action is necessary to comply.

1. Calculate the amount of refrigerant (kg) charged to each system separately.

amount of refrigerant in a single unit system (amount of refrigerant with which the system is charged before leaving the factory)	+	additional charging amount (amount of refrigerant added locally in accordance with the length or diameter of the refrigerant piping)	=	total amount of refrigerant (kg) in the system
---	---	--	---	--

Note

- Where a single refrigerant facility is divided into 2 entirely independent refrigerant systems then use the amount of refrigerant with which each separate system is charged.
2. Calculate the smallest room volume (m^3)
- Incase like the following, calculate the volume of (A), (B) as a single room or as the smallest room.

- A. Where there are no smaller room divisions

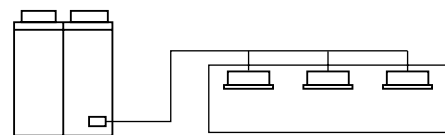

- B. Where there is a room division but there is an opening between the rooms sufficiently large to permit a free flow of air back and forth.

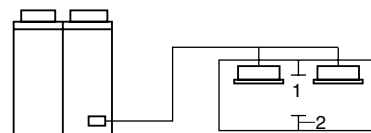

1. opening between rooms
2. partition

(Where there is an opening without a door or where there are openings above and below the door which are each equivalent in size to 0.15% or more of the floor area.)

