

**DAIKIN**



## Installation, Operation and Maintenance Manual

D – KIMWC00512-09EN



## Water-cooled screw chillers

EWQ 400-C20 AJYNN  
EWQ 440-C22 AJYNN/A  
50Hz – Refrigerant: R-410A

Original Instructions

# Contents

---

<b>General information</b> .....	<b>5</b>
Warnings for the operator .....	5
Assistance .....	5
Spare parts .....	5
Receiving the machine .....	5
Checks .....	6
Purpose of this manual .....	6
Important information on the refrigerant used .....	6
NOMENCLATURE .....	8
<b>Operating limits</b> .....	<b>18</b>
Storing .....	18
Operation .....	18
<b>Mechanical Installation</b> .....	<b>20</b>
Shipping .....	20
Responsibility .....	20
Safety .....	20
Moving and lifting .....	20
Positioning and assembly .....	21
Minimum space requirements .....	22
Ventilation .....	22
Sound protection .....	22
Water piping .....	22
Water treatment .....	24
Evaporator and exchangers anti-freeze protection .....	24
Installing the flow switch .....	24
<b>Electrical Installation</b> .....	<b>38</b>
General specifications .....	38
Electrical components .....	41
Electrical wiring .....	41
Electrical heaters .....	41
Water pump control .....	41
Unit On/Off remote control – Electrical wiring .....	41
Double Setpoint – Electrical wiring .....	41
External water Setpoint reset – Electrical wiring (Optional) .....	41
Unit limitation – Electrical wiring (Optional) .....	42
<b>Operation</b> .....	<b>42</b>
<b>Operation</b> .....	<b>43</b>
Operator's responsibilities .....	43
Description of the machine .....	43
Description of the refrigeration cycle .....	43
Description of the refrigeration cycle with partial heat recovery .....	48
Controlling the partial recovery circuit and installation recommendations .....	48
Compression process .....	49
<b>Pre-startup checks</b> .....	<b>53</b>
General .....	53
Units with external water pump .....	54
Electrical power supply .....	54
Unbalance in power supply voltage .....	54
Electrical heaters power supply .....	54
Emergency Stop .....	54
<b>Startup procedure</b> .....	<b>55</b>
Turning on the machine .....	55
Seasonal shutdown .....	56
Starting up after seasonal shutdown .....	56
<b>System maintenance</b> .....	<b>57</b>
General .....	57
Compressor maintenance .....	57
Lubrication .....	57
7) Safety valves .....	59
Check that the lid and seal have not been tampered with .....	59
Check that the discharge socket of the safety valves is not obstructed by any objects, rust or ice .....	59
Check the manufacturing date shown on the safety valve. Replace the valve every 5 years and make sure it is compliant with the current regulations in terms of the installation of the unit .....	59
Replacement of filter dryer .....	59
Procedure to replace the filter dryer cartridge .....	60
Replacement of filter dryer .....	60

Procedure to replace the filter dryer cartridge .....	60
Replacement of the oil filter .....	61
Fr3200 compressor.....	61
FR4 compressor .....	62
Fr4200 compressor.....	62
Refrigerant charge.....	63
Procedure to replenish refrigerant .....	64
<b>Standard Checks.....</b>	<b>65</b>
Temperature and pressure sensors .....	65
<b>Test sheet .....</b>	<b>66</b>
Water side measurements.....	66
Refrigerant side measurements .....	66
Electrical measurements .....	66
<b>Service and limited warranty.....</b>	<b>67</b>
<b>Obligatory routine checks and starting up apparatuses under pressure .....</b>	<b>68</b>
<b>Important information regarding the refrigerant used.....</b>	<b>68</b>

## List of tables

<i>Table 1 – EWWQ 400-C20 AJYNN - Technical Data.....</i>	<i>9</i>
<i>Table 2 - EWWQ 400-C20 AJYNN - Technical Data .....</i>	<i>10</i>
<i>Table 3 - EWWQ 400-C20 AJYNN - Technical Data .....</i>	<i>11</i>
<i>Table 4 - EWWQ 400-C20 AJYNN - Technical Data .....</i>	<i>12</i>
<i>Table 5 - EWWQ 440-C22 AJYNN/A - Technical Data.....</i>	<i>13</i>
<i>Table 6 - EWWQ 440-C22 AJYNN/A - Technical Data .....</i>	<i>14</i>
<i>Table 7 - EWWQ 440-C22 AJYNN/A - Technical Data.....</i>	<i>15</i>
<i>Table 8 - EWWQ 440-C22 AJYNN/A - Technical Data.....</i>	<i>16</i>
<i>Table 9 - Sound levels EWWQ – AJYNN.....</i>	<i>17</i>
<i>Table 10 - Sound levels EWWQ – AJYNN/A.....</i>	<i>17</i>
<i>Table 11 – Acceptable water quality limits.....</i>	<i>24</i>
<i>Table 12 – Electrical data EWWQ-AJYNN Unit .....</i>	<i>39</i>
<i>Table 13 – Electrical data EWWQ – AJYNN/A Unit.....</i>	<i>40</i>
<i>Table 13 - Typical operating conditions with compressors at 100%.....</i>	<i>55</i>
<i>Table 15 – Routine maintenance programme.....</i>	<i>59</i>

## List of Figures

<i>Fig. 1 – Operating limits.....</i>	<i>19</i>
<i>Fig. 2 - Lifting the unit.....</i>	<i>21</i>
<i>Fig. 3 – Minimum clearance requirements for machine maintenance.....</i>	<i>22</i>
<i>Fig. 4 – Water piping connection for heat recovery exchangers .....</i>	<i>23</i>
<i>Fig. 5 - Adjusting the safety flow switch.....</i>	<i>25</i>
<i>Fig. 6 – Evaporator pressure drop – EWWQ - AJYNN.....</i>	<i>26</i>
<i>Fig. 7 – Evaporator pressure drop – EWWQ - AJYNN.....</i>	<i>27</i>
<i>Fig. 8 – Evaporator pressure drop - EWWQ – AJYNN/A.....</i>	<i>28</i>
<i>Fig. 9 – Evaporator pressure drop - EWWQ - AJYNN /A.....</i>	<i>29</i>
<i>Fig. 10 – Condenser pressure drop - EWWQ - AJYNN.....</i>	<i>30</i>
<i>Fig. 11 – Condenser pressure drop - EWWQ - AJYNN.....</i>	<i>31</i>
<i>Fig. 12 – Condenser pressure drop - EWWQ – AJYNN/A.....</i>	<i>32</i>
<i>Fig. 13 – Condenser pressure drop - EWWQ – AJYNN/A.....</i>	<i>33</i>
<i>Fig. 14 – Partial heat recovery pressure drop - EWWQ – AJYNN .....</i>	<i>34</i>
<i>Fig. 15 – Partial heat recovery pressure drop - EWWQ – AJYNN .....</i>	<i>35</i>
<i>Fig. 16 – Partial heat recovery pressure drop - EWWQ – AJYNN/A.....</i>	<i>36</i>
<i>Fig. 17 – Partial heat recovery pressure drop - EWWQ – AJYNN/A.....</i>	<i>37</i>
<i>Fig. 18 – User connection to the interface M3 terminal board .....</i>	<i>42</i>
<i>Fig. 19 - Refrigeration cycle of the EWWQ – AJYNN / EWWQ – AJYNN/A DUAL Fr4 unit.....</i>	<i>44</i>
<i>Fig. 20 - Refrigeration cycle of the EWWQ – AJYNN / EWWQ – AJYNN/A Mono Fr4 unit.....</i>	<i>45</i>
<i>Fig. 21 - Refrigeration cycle of the EWWQ – AJYNN / EWWQ – AJYNN/A DUAL 3200 unit.....</i>	<i>46</i>
<i>Fig. 22 - Refrigeration cycle of the EWWQ – AJYNN / EWWQ – AJYNN/A Mono 3200 unit.....</i>	<i>47</i>
<i>Fig. 23 - Picture of Fr4100 compressor.....</i>	<i>49</i>
<i>Fig. 24 – Picture of Fr3200 compressor .....</i>	<i>49</i>
<i>Fig. 25 - Compression process.....</i>	<i>50</i>
<i>Fig. 26 - Refrigeration capacity control mechanism of compressor Fr3200 – Fr4 .....</i>	<i>51</i>
<i>Fig. 27 - Capacity control mechanism.....</i>	<i>52</i>
<i>Fig. 28 - Installation of control devices for Fr4 compressor .....</i>	<i>58</i>
<i>Fig. 29 - Installation of control devices for Fr3200 compressor .....</i>	<i>58</i>

## General information

### IMPORTANT

The units described in the present manual represent a valuable investment. Maximum care should be taken to ensure correct installation and appropriate working conditions of the units.  
Installation and maintenance must be performed by qualified and specifically trained personnel only.  
Correct maintenance of the unit is indispensable for its safety and reliability. Manufacturer's service centres are the only having adequate technical skill for maintenance.

### CAUTION

This manual provides information about the features and procedures for the complete series.

All units are delivered from factory as complete sets which include wiring diagrams and dimensional drawings with size, weight and features of each model.

#### **WIRING DIAGRAMS AND DIMENSIONAL DRAWINGS MUST BE CONSIDERED ESSENTIAL DOCUMENTS OF THIS MANUAL**

In case of any discrepancy between this manual and the two aforesaid documents, please refer to the wiring diagram and dimensional drawings.

### WARNING

Before starting the installation of the unit, please read this manual carefully. Starting up the unit is absolutely forbidden if all instructions contained in this manual are not clear.

## Warnings for the operator

- READ THIS MAINTENANCE AND USE MANUAL BEFORE USING THE UNIT
- THE OPERATOR MUST BE TRAINED AND INSTRUCTED ON HOW TO USE THE UNIT
- THE OPERATOR MUST STRICTLY FOLLOW ALL INSTRUCTIONS, SAFETY REGULATIONS AND LIMITATIONS REGARDING THE USE OF THE UNIT.

### Key to symbols



Important note: failure to respect the instruction can damage the unit or compromise functioning



Note regarding safety in general or respect of laws and regulations



Note concerning electrical safety

Safe use and maintenance of the unit, as explained in this Maintenance and Use Manual, is fundamental to prevent any accidents occurring to operators during both operation and maintenance as well as during repair work.

Therefore, it is highly recommended that this document be read carefully, complied with and stored safely.

## Assistance

Should additional maintenance be required, it is advisable to consult authorised staff before carrying out any repair work.

## Spare parts

Spare parts to be used for maintenance of the unit must be original. Therefore, always consult the manufacturer.

## Receiving the machine

The machine must be inspected for any possible damage immediately upon reaching its final place of installation. All components described in the delivery note must be carefully inspected and checked; any damage must be reported to

the carrier. Before connecting the machine to earth, check that the model and power supply voltage shown on the nameplate are correct. Responsibility for any damage after acceptance of the machine cannot be attributed to the manufacturer.

## Checks

To prevent the possibility of incomplete delivery (missing parts) or transportation damage, please perform the following checks upon receipt of the machine:

- Before accepting the machine, please verify every single component in the consignment. Check for any damage.
- In the event that the machine has been damaged, do not remove the damaged material. A set of photographs are helpful in ascertaining responsibility.
- Immediately report the extent of the damage to the transportation company and request that they inspect the machine.
- Immediately report the extent of the damage to the manufacturer representative, so that arrangements can be made for the required repairs. In no case must the damage be repaired before the machine has been inspected by the representative of the transportation company.

## Purpose of this manual

The purpose of this manual is to allow the installer and the qualified operator to carry out all required operations in order to ensure proper installation and maintenance of the machine, without any risk to people, animals and/or objects.

This manual is an important supporting document for qualified personnel but it is not intended to replace such personnel. All activities must be carried out in compliance with local laws and regulations.

## Important information on the refrigerant used

This product contains fluorate gases which have a greenhouse effect and which are covered by the Kyoto protocol. Do not release such gases into the atmosphere.

Type of refrigerant: R410A

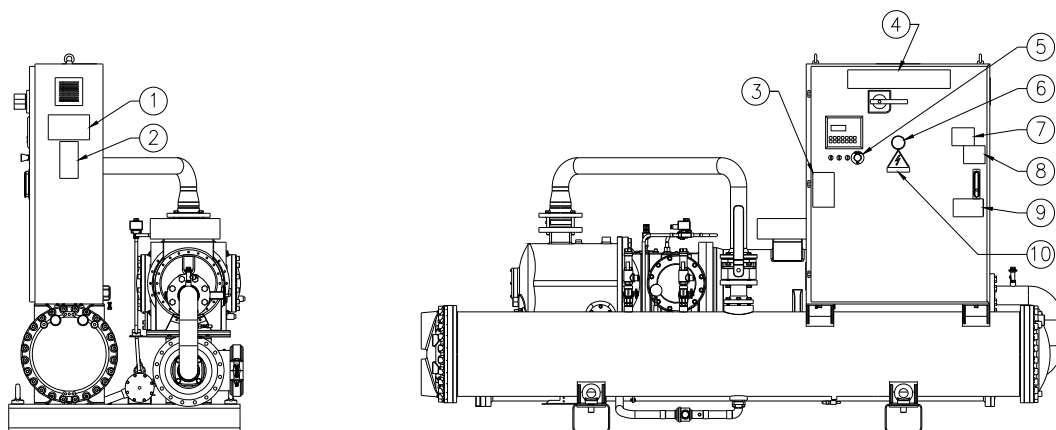
GWP value<sup>(1)</sup> = 1975

The quantity of refrigerant used is indicated on the identity plate with the name of the unit.

Routine inspections may be necessary pursuant to local and/or European laws, to check on possible refrigerant leakage. For more detailed information, contact your local dealer.

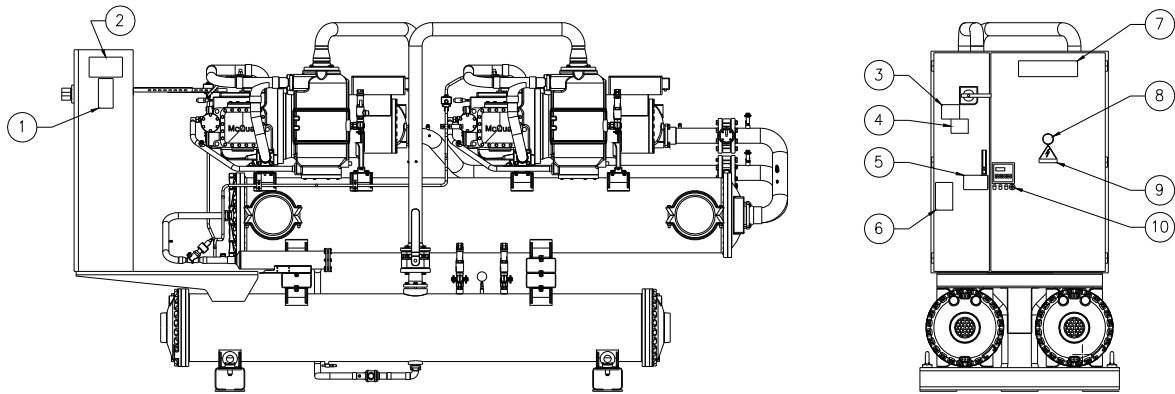
<sup>(1)</sup> GWP=Global warming potential

### Description of the labels applied to the electrical panel



### Single Compressor unit

1 – Lifting instructions	6 – Gas type
2 – Unit nameplate data	7 – Hazardous Voltage warning
3 – Non flammable gas symbol	8 – Cable tightening warning
4 – Manufacturer's logo	9 – Water circuit filling warning
5 – Emergency stop	10 – Electrical hazard symbol



### Two Compressors Unit

<b>1</b> – Unit nameplate data	<b>6</b> – Non flammable gas symbol
<b>2</b> – Lifting instructions	<b>7</b> – Manufacturer's logo
<b>3</b> – Hazardous Voltage warning	<b>8</b> – Gas type
<b>4</b> – Cable tightening warning	<b>9</b> – Electrical hazard symbol
<b>5</b> – Water circuit filling warning	<b>10</b> – Emergency stop

# NOMENCLATURE

**EWW Q 400 AJ YN N \*\*\*\* /A**

## Machine type

ERA: Air-cooled condensing unit  
 EWW: Water cooled packaged water chiller  
 EWL: Remote condenser water chiller  
 EWA: Air-cooled chiller, cooling only  
 EWY: Air-cooled chiller, heat pump  
 EWC: Air-cooled chiller, cooling only with centrifugal fan  
 EWT: Air-cooled chiller, cooling only with heat recovery

## Refrigerant

D: R-134a  
 P: R-407C  
 Q: R-410A

## Capacity class in kW (cooling)

### Always 3-digit code

Cap < 50 kW: not rounded: example: 37 kW => **037**  
 50 < Cap < 999 kW: rounded 0/5: 536 kW => **535**  
 Cap > 999 kW use C-symbol (C=100): example: 2578 kW => **C26**

## Model series

first character : letter A, B,...: major modification  
 second character : letter A,B,... : minor modification DENV  
 letter J-W... : minor modification New Series

## Voltage

V1: ~ / 220 - 240 V / 50 Hz  
 V3: 1~ / 230 V / 50 Hz  
 T1: 3~ / 230 V / 50 Hz  
 W1: 3N~ / 400 V / 50 Hz  
 Y1: 3~ / 380-415 V / 50 Hz  
 YN: 3~ / 400 V / 50 Hz

## Hydraulic module/Heat recovery version/Pump & electrical options (Consult Selection software)

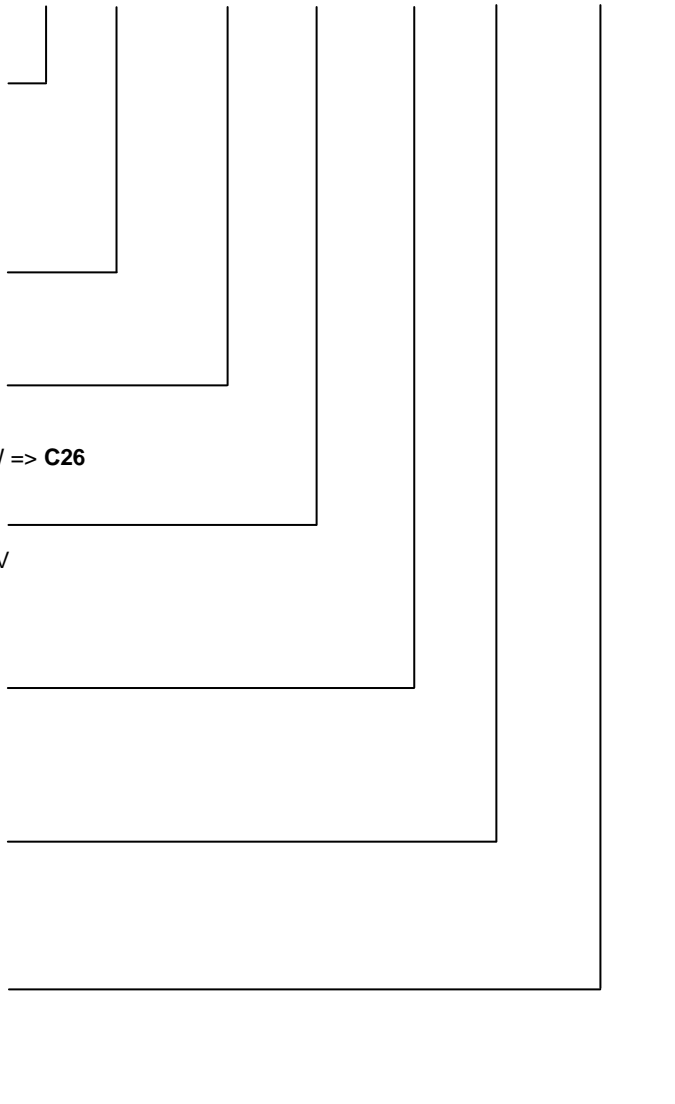
N: No Hydraulic components  
 M: Modular  
 A-V: Combination of specific options

## Option code (Consult Selection software)

\*\*\*\*: 4 digits

## Option regarding efficiency version, sound version

/H: High ambient version  
 /A: High efficiency version  
 /Q: Extra low noise version  
 /Z: High efficiency and Extra low noise version



# TECHNICAL SPECIFICATIONS

**Table 1 – EWWQ 400-C20 AJYNN - Technical Data**

TECHNICAL SPECIFICATIONS			EWQ - AJYNN	400	480	600	650	750
Capacity	Cooling	kW		388	474	574	651	742
Capacity control	Type		Stepless					
	Minimum capacity	%	25	25	25	25	25	
Unit power input	Cooling	kW	87	106	130	148	170	
EER			4.44	4.46	4.40	4.41	4.37	
ESEER			4.95	4.98	4.97	4.97	4.72	
Casing	Colour		RAL7032					
	Material		Galvanized and painted steel sheet					
Dimensions	Unit	Height	mm	1846	1846	2000	2000	1846
		Width	mm	1140	1140	1276	1276	1316
		Depth	mm	3431	3431	3440	3440	3561
Weight	Unit		kg	1933	1967	2283	2332	2407
	Operating Weight		kg	2135	2169	2543	2628	2777
Water heat exchanger Evaporator	Type		Shell and tubes					
	Water volume		l	124	118	176	170	274
	Nominal water flow rate	Cooling	l/s	18.5	22.7	27.4	31.1	35.4
		Cooling	kPa	49	65	45	48	55
	Insulation material		Closet cell foam elastomer					
Water heat exchanger Condenser	Type		Shell and tubes					
	Number of condensers		No.	1	1	1	1	1
	Water volume		l	79	92	84	126	97
	Nominal water flow rate	Cooling	l/s	22.9	27.9	33.9	38.5	43.9
		Cooling	kPa	60	64	68	66	16
	Insulation Material		Expanded elastomer					
Compressor	Type		Semi-hermet. single screw compr.					
	Oil charge		l	16	16	16	16	16
	Quantity			1	1	1	1	1
Sound level	Sound Power	Cooling	dBA	100.2	101.1	102.3	102.3	101.5
	Sound Pressure	Cooling	dBA	82	83	84	84	83
Refrigerant circuit	Refrigerant type		R410A	R410A	R410A	R410A	R410A	
	Refrigerant charge		kg	80	80	90	90	100
	N. of circuits			1	1	1	1	1
Piping connections	Evaporator water inlet/outlet		mm	168.3	168.3	219.1	219.1	219.1
Piping connections	Condenser water inlet/outlet		in	5"	5"	5"	5"	6"
Safety devices	High pressure (pressure switch)							
Safety devices	Low pressure (pressure switch)							
Safety devices	Emergency stop							
Safety devices	High discharge temperature on the compressor							
Safety devices	Phase monitor							
Safety devices	Low pressure ratio							
Safety devices	High oil pressure drop							
Safety devices	Low oil pressure							
Notes	Cooling capacity, unit power input in cooling and EER are based on the following conditions: evaporator 12°C/7°C; condenser 30/ 35°C.							



**Table 2 - EWWQ 400-C20 AJYNN - Technical Data**

TECHNICAL SPECIFICATIONS			EWWQ - AJYNN		800	850	900	C10	C11
Capacity	Cooling	kW	813	880	891	980	1028		
Capacity control	Type		Stepless						
	Minimum capacity	%	25	25	12.5	12.5	12.5		
Unit power input	Cooling	kW	175	206	194	213	245		
EER			4.64	4.26	4.59	4.60	4.19		
ESEER			5.37	4.60	5.36	5.34	4.53		
Casing	Colour		RAL7032						
	Material		Galvanized and painted steel sheet						
Dimensions	Unit	Height	mm	2170	1846	2170	2170	1846	
		Width	mm	1350	1316	1350	1350	1335	
		Depth	mm	4902	3561	4902	4902	3561	
Weight	Unit		kg	3921	2427	3949	3988	2457	
	Operating Weight		kg	4422	2795	4463	4496	2812	
Water heat exchanger Evaporator	Type		Shell and tubes						
	Water volume		l	344	266	344	325	251	
	Nominal water flow rate	Cooling	l/s	38.8	42.0	42.6	46.8	49.1	
	Nominal Water pressure drop	Cooling	kPa	54	50	64	59	57	
	Insulation material		Closet cell foam elastomer						
Water heat exchanger Condenser	Type		Shell and tubes						
	Number of condensers		No.	2	1	2	2	1	
	Water volume		l	1)79 2)79	102	1)79 2)92	1)92 2)92	104	
	Nominal water flow rate	Cooling	l/s	1)23.8 2)23.8	52.3	1)23.8 2)28.5	1)28.7 2)28.7	61.3	
	Nominal Water pressure drop	Nominal Water pressure drop	kPa	1)64 2)64	20	1)64 2)67	1)68 2)68	26	
	Insulation Material		Expanded elastomer						
Compressor	Type		Semi-hermet. Single screw compr.						
	Oil charge		l	32	16	32	32	16	
	Quantity			2	1	2	2	1	
Sound level	Sound Power	Cooling	dBA	104.7	102.3	104.7	105.1	103.2	
	Sound Pressure	Cooling	dBA	84	85	85	85	86	
Refrigerant circuit	Refrigerant type		R410A	R410A	R410A	R410A	R410A		
	Refrigerant charge	kg	1)85 2)85	100	1)85 2)85	1)85 2)85	100		
	N. of circuits			2	1	2	2	1	
Piping connections	Evaporator water inlet/outlet		mm	219.1	219.1	219.1	219.1	219.1	
Piping connections	Condenser water inlet/outlet		in	5"	6"	5"	5"	6"	
Safety devices	High pressure (pressure switch)								
Safety devices	Low pressure (pressure switch)								
Safety devices	Emergency stop								
Safety devices	High discharge temperature on the compressor								
Safety devices	Phase monitor								
Safety devices	Low pressure ratio								
Safety devices	High oil pressure drop								
Safety devices	Low oil pressure								
Notes	Cooling capacity, unit power input in cooling and EER are based on the following conditions: evaporator 12°C/7°C; condenser 30/ 35°C.								

**Table 3 - EWWQ 400-C20 AJYNN - Technical Data**

TECHNICAL SPECIFICATIONS			EWWQ - AJYNN	C12	C13	C14	C15	C16
Capacity	Cooling	kW	1077	1210	1281	1352	1488	
Capacity control	Type		Stepless					
	Minimum capacity	%	12.5	12.5	12.5	12.5	12.5	
Unit power input	Cooling	kW	237	262	279	296	340	
EER			4.55	4.62	4.59	4.56	4.38	
ESEER			5.33	5.36	5.35	5.29	4.93	
Casing	Colour		RAL7032					
	Material		Galvanized and painted steel sheet					
Dimensions	Unit	Height	mm	2379	2455	2455	2455	2547
		Width	mm	1350	1350	1350	1350	1350
		Depth	mm	4912	4835	4835	4835	4844
Weight	Unit		kg	4344	4529	4536	4607	4988
	Operating Weight		kg	4780	5186	5200	5280	5602
Water heat exchanger Evaporator	Type		Shell and tubes					
	Water volume		l	325	538	538	538	505
	Nominal water flow rate	Cooling	l/s	51.5	57.8	61.2	64.6	71.0
	Nominal Water pressure drop	Cooling	kPa	70	45	50	55	60
	Insulation material		Closet cell foam elastomer					
Water heat exchanger Condenser	Type		Shell and tubes					
	Number of condensers		No.	2	2	2	2	2
	Water volume		l	1)52 2)60	1)60 2)60	1)60 2)68	1)68 2)68	1)54 2)54
	Nominal water flow rate	Cooling	l/s	1)28.7 2)34.5	1)35.4 2)35.4	1)35.4 2)39.7	1)39.7 2)39.7	1)44.0 2)44.0
	Nominal Water pressure drop	Nominal Water pressure drop	kPa	1)68 2)70	1)73 2)73	1)73 2)70	1)70 2)70	1)17 2)17
	Insulation Material		Expanded elastomer					
Compressor	Type		Semi-hermet. Single screw compr.					
	Oil charge		l	32	32	32	32	32
	Quantity			2	2	2	2	2
Sound level	Sound Power	Cooling	dBA	104.7	105.2	106.5	106.5	105.8
	Sound Pressure	Cooling	dBA	86	87	87	87	86
Refrigerant circuit	Refrigerant type			R410A	R410A	R410A	R410A	R410A
	Refrigerant charge		kg	1)95 2)95	1)100 2)100	1)100 2)100	1)100 2)100	1)130 2)130
	N. of circuits			2	2	2	2	2
Piping connections	Evaporator water inlet/outlet		mm	219.1	273	273	273	273
Piping connections	Condenser water inlet/outlet		in	5"	5"	5"	5"	6"
Safety devices	High pressure (pressure switch)							
Safety devices	Low pressure (pressure switch)							
Safety devices	Emergency stop							
Safety devices	High discharge temperature on the compressor							
Safety devices	Phase monitor							
Safety devices	Low pressure ratio							
Safety devices	High oil pressure drop							
Safety devices	Low oil pressure							
Notes	Cooling capacity, unit power input in cooling and EER are based on the following conditions: evaporator 12°C/7°C; condenser 30/ 35°C.							

**Table 4 - EWWQ 400-C20 AJYNN - Technical Data**

TECHNICAL SPECIFICATIONS			EWQ - AJYNN	C17	C18	C19	C20
Capacity	Cooling		kW	1620	1783	1928	2093
Capacity control	Type			Stepless			
	Minimum capacity		%	12.5	12.5	12.5	12.5
Unit power input	Cooling		kW	375	409	442	475
EER				4.32	4.36	4.37	4.40
ESEER				4.93	4.82	4.89	4.87
Casing	Colour			RAL7032			
	Material			Galvanized and painted steel sheet			
Dimensions	Unit	Height	mm	2547	2547	2547	2547
		Width	mm	1350	1350	1350	1350
		Depth	mm	4844	4844	4809	4809
Weight	Unit		kg	4999	5053	5204	5289
	Operating Weight		kg	5615	5670	5881	5970
Water heat exchanger Evaporator	Type			Shell and tubes			
	Water volume		l	505	495	539	527
	Nominal water flow rate	Cooling	l/s	77.3	85.1	92.0	99.8
	Nominal Water pressure drop	Cooling	kPa	70	89	99	123
	Insulation material			Closed cell foam elastomer			
Water heat exchanger Condenser	Type			Shell and tubes			
	Number of condensers		No.	2	2	2	2
	Water volume		l	1)54 2)57	1)61 2)61	1)61 2)77	1)77 2)77
	Nominal water flow rate	Cooling	l/s	1)44.0 2)52.0	1)52.7 2)52.7	1)53.0 2)61.0	1)61.8 2)61.8
	Nominal Water pressure drop	Nominal Water pressure drop	kPa	1)17 2)19	1)17 2)17	1)17 2)15	1)15 2)15
	Insulation Material			Expanded elastomer			
	Compressor	Type			Semi-hermet. single screw compr.		
Oil charge		l	32	32	32	32	
Quantity			2	2	2	2	
Sound level	Sound Power	Cooling	dBa	106.2	106.6	107.1	107.5
	Sound Pressure	Cooling	dBa	87	87	88	88
Refrigerant circuit	Refrigerant type			R-410A	R-410A	R-410A	R-410A
	Refrigerant charge		kg	1)130 2)130	1)130 2)130	1)130 2)130	1)130 2)130
	N. of circuits			2	2	2	2
Piping connections	Evaporator water inlet/outlet		mm	273	273	273	273
Piping connections	Condenser water inlet/outlet		in	6"	6"	6"	6"
Safety devices	High pressure (pressure switch)						
Safety devices	Low pressure (pressure switch)						
Safety devices	Emergency stop						
Safety devices	High discharge temperature on the compressor						
Safety devices	Phase monitor						
Safety devices	Low pressure ratio						
Safety devices	High oil pressure drop						
Safety devices	Low oil pressure						
Notes	Cooling capacity, unit power input in cooling and EER are based on the following conditions: evaporator 12°C/7°C; condenser 30/35°C.						

**Table 5 - EWWQ 440-C22 AJYNN/A - Technical Data**

TECHNICAL SPECIFICATIONS			EWWQ – AJYNN/A		440	550	650	750	800
Capacity	Cooling	kW	431	527	653	740	818		
Capacity control	Type		Stepless						
	Minimum capacity	%	25	25	25	25	25		
Unit power input	Cooling	kW	87	105	128	146	162		
EER			4.97	5.03	5.09	5.07	5.05		
ESEER			5.58	5.61	5.69	5.67	5.64		
Casing	Colour		RAL7032						
	Material		Galvanized and painted steel sheet						
Dimensions	Unit	Height	mm	2000	2000	2000	2001	2000	
		Width	mm	1261	1261	1261	1260	1316	
		Depth	mm	3987	3987	3987	3855	3854	
Weight	Unit		kg	2322	2403	2464	2738	2407	
	Operating Weight		kg	2594	2685	2745	3158	2815	
Water heat exchanger Evaporator	Type		Shell and tubes						
	Water volume		l	220	213	200	334	325	
	Nominal water flow rate	Cooling	l/s	20.6	25.2	31.2	35.4	39.1	
	Nominal Water pressure drop	Cooling	kPa	59	73	76	68	60	
	Insulation material		Closet cell foam elastomer						
Water heat exchanger Condenser	Type		Shell and tubes						
	Number of condensers		No.	1	1	1	1	1	
	Water volume		l	52	69	81	86	83	
	Nominal water flow rate	Cooling	l/s	24.7	30.2	37.3	42.3	46.8	
	Nominal Water pressure drop	Nominal Water pressure drop	kPa	52	42	43	48	62	
Insulation Material		Expanded elastomer							
Compressor	Type		Semi-hermet. single screw compr.						
	Oil charge		l	16	16	16	16	16	
	Quantity			1	1	1	1	1	
Sound level	Sound Power	Cooling	dBA	100.9	101.7	102.6	102.7	102.0	
	Sound Pressure	Cooling	dBA	82	83	84	84	83	
Refrigerant circuit	Refrigerant type		R410A	R410A	R410A	R410A	R410A		
	Refrigerant charge		kg	95	95	95	95	110	
	N. of circuits			1	1	1	1	1	
Piping connections	Evaporator water inlet/outlet		mm	219.1	219.1	219.1	219.1	219.1	
Piping connections	Condenser water inlet/outlet		in	5"	5"	5"	5"	5"	
Safety devices	High pressure (pressure switch)								
Safety devices	Low pressure (pressure switch)								
Safety devices	Emergency stop								
Safety devices	High discharge temperature on the compressor								
Safety devices	Phase monitor								
Safety devices	Low pressure ratio								
Safety devices	High oil pressure drop								
Safety devices	Low oil pressure								
Notes	Cooling capacity, unit power input in cooling and EER are based on the following conditions: evaporator 12°C/7°C; condenser 30/ 35°C.								

**Table 6 - EWWQ 440-C22 AJYNN/A - Technical Data**

TECHNICAL SPECIFICATIONS				EWQ – AJYNN/A	950	C10	C11	C12	C13
Capacity	Cooling		kW	993	1059	1139	1182	1297	
Capacity control	Type			Stepless					
	Minimum capacity		%	25	12.5	25	12.5	12.5	
Unit power input	Cooling		kW	197	209	232	233	258	
EER				5.05	5.06	4.91	5.07	5.04	
ESEER				5.39	5.89	5.28	5.87	5.88	
Casing	Colour			RAL7032					
	Material			Galvanized and painted steel sheet					
Dimensions	Unit	Height	mm	2001	2453	2001	2453	2453	
		Width	mm	1448	1350	1448	1350	1350	
		Depth	mm	3891	4985	3891	4985	4985	
Weight	Unit		kg	2427	4775	2457	4831	4873	
	Operating Weight		kg	3056	5431	3086	5479	5512	
Water heat exchanger Evaporator	Type			Shell and tubes					
	Water volume		l	538	587	538	575	563	
	Nominal water flow rate	Cooling	l/s	47.4	50.6	54.4	56.5	62.0	
		Cooling	kPa	57	57	73	67	58	
	Insulation material			Closet cell foam elastomer					
Water heat exchanger Condenser	Type			Shell and tubes					
	Number of condensers		No.	1	2	1	2	2	
	Water volume		l	91	1)69 2)70	91	1)73 2)76	1)76 2)76	
	Nominal water flow rate	Cooling	l/s	56.9	1)30.3 2)30.3	65.5	1)30.4 2)37.2	1)37.2 2)37.2	
		Nominal Water pressure drop	Nominal Water pressure drop	kPa	67	1)41 2)41	87	1)37 2)50	1)50 2)50
	Insulation Material			Expanded elastomer					
Compressor	Type			Semi-hermet. single screw compr.					
	Oil charge		l	16	32	16	32	32	
	Quantity			1	2	1	2	2	
Sound level	Sound Power	Cooling	dBA	102.9	105.2	103.8	105.6	106.1	
	Sound Pressure	Cooling	dBA	84	86	85	86	87	
Refrigerant circuit	Refrigerant type			R410A	R410A	R410A	R410A	R410A	
	Refrigerant charge		kg	130	1)120 2)120	130	1)120 2)120	1)120 2)120	
	N. of circuits			1	2	1	2	2	
Piping connections	Evaporator water inlet/outlet		mm	273	273	273	273	273	
Piping connections	Condenser water inlet/outlet		in	5"	5"	5"	5"	5"	
Safety devices	High pressure (pressure switch)								
Safety devices	Low pressure (pressure switch)								
Safety devices	Emergency stop								
Safety devices	High discharge temperature on the compressor								
Safety devices	Phase monitor								
Safety devices	Low pressure ratio								
Safety devices	High oil pressure drop								
Safety devices	Low oil pressure								
Notes	Cooling capacity, unit power input in cooling and EER are based on the following conditions: evaporator 12°C/7°C; condenser 30/ 35°C.								

**Table 7 - EWWQ 440-C22 AJYNN/A - Technical Data**

TECHNICAL SPECIFICATIONS			EWWQ – AJYNN/A	C14	C15	C16	C18	C19
Capacity	Cooling	kW	1397	1479	1605	1769	1901	
Capacity control	Type		Stepless					
	Minimum capacity	%	12.5	12.5	12.5	12.5	12.5	
Unit power input	Cooling	kW	275	292	321	356	390	
EER			5.08	5.07	4.99	4.96	4.87	
ESEER			5.98	5.93	5.67	5.71	5.48	
Casing	Colour		RAL7032					
	Material		Galvanized and painted steel sheet					
Dimensions	Unit	Height	mm	2453	2453	2547	2547	2547
		Width	mm	1350	1350	1350	1350	1350
		Depth	mm	4985	4985	4844	4844	4809
Weight	Unit		kg	4919	4969	5117	5177	5388
	Operating Weight		kg	5546	5606	5794	5843	6110
Water heat exchanger Evaporator	Type		Shell and tubes					
	Water volume		l	551	551	495	484	535
	Nominal water flow rate	Cooling	l/s	66.7	70.7	76.7	84.5	90.8
	Nominal Water pressure drop	Cooling	kPa	71	79	74	94	96
	Insulation material		Closet cell foam elastomer					
Water heat exchanger Condenser	Type		Shell and tubes					
	Number of condensers		No.	2	2	2	2	2
	Water volume		l	1)75 2)86	1)86 2)86	1)91 2)91	1)91 2)91	1)91 2)91
	Nominal water flow rate	Cooling	l/s	1)37.6 2)42.3	1)42.3 2)42.3	1)46.0 2)46.0	1)45.7 2)55.8	1)54.7 2)54.7
	Nominal Water pressure drop	Nominal Water pressure drop	kPa	1)50.7 2)48.4	1)48.4 2)48.4	1)45 2)45	1)45 2)65	1)63 2)63
	Insulation Material		Expanded elastomer					
	Compressor	Type		Semi-hermet. single screw compr.				
Oil charge		l	32	32	32	32	32	
Quantity			2	2	2	2	2	
Sound level	Sound Power	Cooling	dB(A)	106.1	106.5	105.8	106.2	106.6
	Sound Pressure	Cooling	dB(A)	87	87	86	87	87
Refrigerant circuit	Refrigerant type		R410A	R410A	R410A	R410A	R410A	R410A
	Refrigerant charge		kg	1)120 2)120	1)120 2)120	1)130 2)130	1)130 2)130	1)130 2)130
	N. of circuits			2	2	2	2	2
Piping connections	Evaporator water inlet/outlet		mm	273	273	273	273	273
Pipino connections	Condenser water inlet/outlet		in	5"	5"	5"	5"	5"
Safety devices	High pressure (pressure switch)							
Safety devices	Low pressure (pressure switch)							
Safety devices	Emergency stop							
Safety devices	High discharge temperature on the compressor							
Safety devices	Phase monitor							
Safety devices	Low pressure ratio							
Safety devices	High oil pressure drop							
Safety devices	Low oil pressure							
Notes	Cooling capacity, unit power input in cooling and EER are based on the following conditions: evaporator 12°C/7°C; condenser 30/ 35°C.							

**Table 8 - EWWQ 440-C22 AJYNN/A - Technical Data**

TECHNICAL SPECIFICATIONS				EWWQ – AJYNN/A		C20	C22		
Capacity	Cooling		kW	2061	2196				
Capacity control	Type			Stepless					
	Minimum capacity		%	12.5	12.5				
Unit power input	Cooling		kW	426	461				
EER				4.84	4.77				
ESEER				5.50	5.38				
Casing	Colour			RAL7032					
	Material			Galvanized and painted steel sheet					
Dimensions	Unit	Height	mm	2547	2547				
		Width	mm	1350	1350				
		Depth	mm	4809	4809				
Weight	Unit		kg	5408	5414				
	Operating Weight		kg	6118	6124				
Water heat exchanger Evaporator	Type			Shell and tubes					
	Water volume		l	527	527				
	Nominal water flow rate	Cooling	l/s	98.5	104.9				
	Nominal Water pressure drop	Cooling	kPa	119	134				
	Insulation material			Closet cell foam elastomer					
Water heat exchanger Condenser	Type			Shell and tubes					
	Number of condensers		No.	2	2				
	Water volume		l	1)91 2)91	1)91 2)91				
	Nominal water flow rate	Cooling	l/s	1)54.6 2)64.2	1)63.5 2)63.5				
	Nominal Water pressure drop	Nominal Water pressure drop	kPa	1)54 2)83	1)82 2)82				
	Insulation Material			Expanded elastomer					
Compressor	Type			Semi-hermet. single screw compr.					
	Oil charge		l	32	32				
	Quantity			2	2				
Sound level	Sound Power	Cooling	dBA	107.1	107.5				
	Sound Pressure	Cooling	dBA	88	88				
Refrigerant circuit	Refrigerant type			R410A	R410A				
	Refrigerant charge		kg	130	130				
	N. of circuits			2	2				
Piping connections	Evaporator water inlet/outlet		mm	273	273				
Piping connections	Condenseer water inlet/outlet		in	5"	5"				
Safety devices	High pressure (pressure switch)								
Safety devices	Low pressure (pressure switch)								
Safety devices	Emergency stop								
Safety devices	High discharge temperature on the compressor								
Safety devices	Phase monitor								
Safety devices	Low pressure ratio								
Safety devices	High oil pressure drop								
Safety devices	Low oil pressure								
Notes	Cooling capacity, unit power input in cooling and EER are based on the following conditions: evaporator 12°C/7°C; condenser 30/ 35°C.								

**Table 9 - Sound levels EWWQ – AJYNN**

Size	Sound pressure level at 1 m from the unit in free field (ref. $2 \times 10^{-5}$ )								
	63 Hz	125 Hz	250 Hz	500 Hz	1000 Hz	2000 Hz	4000 Hz	8000 Hz	dBA
<b>400</b>	55.1	59.4	71.6	84.1	71.9	72.5	58.5	53.2	<b>82.2</b>
<b>480</b>	55.9	60.2	72.4	84.9	72.7	73.3	59.3	54	<b>83.0</b>
<b>600</b>	56.8	61.1	73.3	85.8	73.6	74.2	60.2	54.9	<b>83.9</b>
<b>650</b>	56.8	61.1	73.3	85.8	73.6	74.2	60.2	54.9	<b>83.9</b>
<b>750</b>	56,1	60,4	72,6	85,1	72,9	73,5	59,5	54,2	<b>83,2</b>
<b>850</b>	56,9	61,2	73,4	85,9	73,7	74,3	60,3	55,0	<b>84,0</b>
<b>C11</b>	57,8	62,1	74,3	86,8	74,6	75,2	61,2	55,9	<b>84,9</b>
<b>800</b>	58.1	62.4	74.6	87.1	74.9	75.5	61.5	56.2	<b>85.2</b>
<b>900</b>	58.1	62.4	74.6	87.1	74.9	75.5	61.5	56.2	<b>85.2</b>
<b>C10</b>	58.5	62.8	75	87.5	75.3	75.9	61.9	56.6	<b>85.6</b>
<b>C12</b>	58.9	63.2	75.4	87.9	75.7	76.3	62.3	57	<b>86.0</b>
<b>C13</b>	59.4	63.7	75.9	88.4	76.2	76.8	62.8	57.5	<b>86.5</b>
<b>C14</b>	59.8	64.1	76.3	88.8	76.6	77.2	63.2	57.9	<b>86.9</b>
<b>C15</b>	59.8	64.1	76.3	88.8	76.6	77.2	63.2	57.9	<b>86.9</b>
<b>C16</b>	59,1	63,4	75,6	88,1	75,9	76,5	62,5	57,2	<b>86,2</b>
<b>C17</b>	59,5	63,8	76,0	88,5	76,3	76,9	62,9	57,6	<b>86,6</b>
<b>C18</b>	59,9	64,2	76,4	88,9	76,7	77,3	63,3	58,0	<b>87,0</b>
<b>C19</b>	60,4	64,7	76,9	89,4	77,2	77,8	63,8	58,5	<b>87,5</b>
<b>C20</b>	60,8	65,1	77,3	89,8	77,6	78,2	64,2	58,9	<b>87,9</b>

**Note:** The values are according to ISO 3744

**Table 10 - Sound levels EWWQ – AJYNN/A**

Size	Sound pressure level at 1 m from the unit in free field (ref. $2 \times 10^{-5}$ )								
	63 Hz	125 Hz	250 Hz	500 Hz	1000 Hz	2000 Hz	4000 Hz	8000 Hz	dBA
<b>440</b>	55.1	59.4	71.6	84.1	71.9	72.5	58.5	53.2	<b>82.2</b>
<b>550</b>	55.9	60.2	72.4	84.9	72.7	73.3	59.3	54	<b>83.0</b>
<b>650</b>	56.8	61.1	73.3	85.8	73.6	74.2	60.2	54.9	<b>83.9</b>
<b>750</b>	56.8	61.1	73.3	85.8	73.6	74.2	60.2	54.9	<b>83.9</b>
<b>800</b>	56,1	60,4	72,6	85,1	72,9	73,5	59,5	54,2	<b>83,2</b>
<b>950</b>	56,9	61,2	73,4	85,9	73,7	74,3	60,3	55,0	<b>84,0</b>
<b>C10</b>	58.5	62.8	75	87.5	75.3	75.9	61.9	56.6	<b>85.6</b>
<b>C11</b>	57,8	62,1	74,3	86,8	74,6	75,2	61,2	55,9	<b>84,9</b>
<b>C12</b>	58.9	63.2	75.4	87.9	75.7	76.3	62.3	57.0	<b>86.0</b>
<b>C13</b>	59.4	63.7	75.9	88.4	76.2	76.8	62.8	57.5	<b>86.5</b>
<b>C14</b>	59.8	64.1	76.3	88.8	76.6	77.2	63.2	57.9	<b>86.9</b>
<b>C15</b>	59.8	64.1	76.3	88.8	76.6	77.2	63.2	57.9	<b>86.9</b>
<b>C16</b>	59,1	63,4	75,6	88,1	75,9	76,5	62,5	57,2	<b>86,2</b>
<b>C18</b>	59,5	63,8	76,0	88,5	76,3	76,9	62,9	57,6	<b>86,6</b>
<b>C19</b>	59,9	64,2	76,4	88,9	76,7	77,3	63,3	58,0	<b>87,0</b>
<b>C20</b>	60,4	64,7	76,9	89,4	77,2	77,8	63,8	58,5	<b>87,5</b>
<b>C22</b>	60,8	65,1	77,3	89,8	77,6	78,2	64,2	58,9	<b>87,9</b>

**Note:** The values are according to ISO 3744



# Operating limits

---

## Storing

The units of the series can be stored under the following environmental conditions:

Minimum ambient temperature	:	-20°C
Maximum ambient temperature	:	41°C
Max. R.H.	:	95% not condensing

### ▲ ATTENTION

Storing below the minimum temperature mentioned above may cause damage to components such as the electronic controller and its LCD display.

### ▲ WARNING

Storing above the maximum temperature may cause opening of the safety valves on the compressor's suction line.

### ▲ ATTENTION

Storing in condensing atmosphere may damage the electronic components.

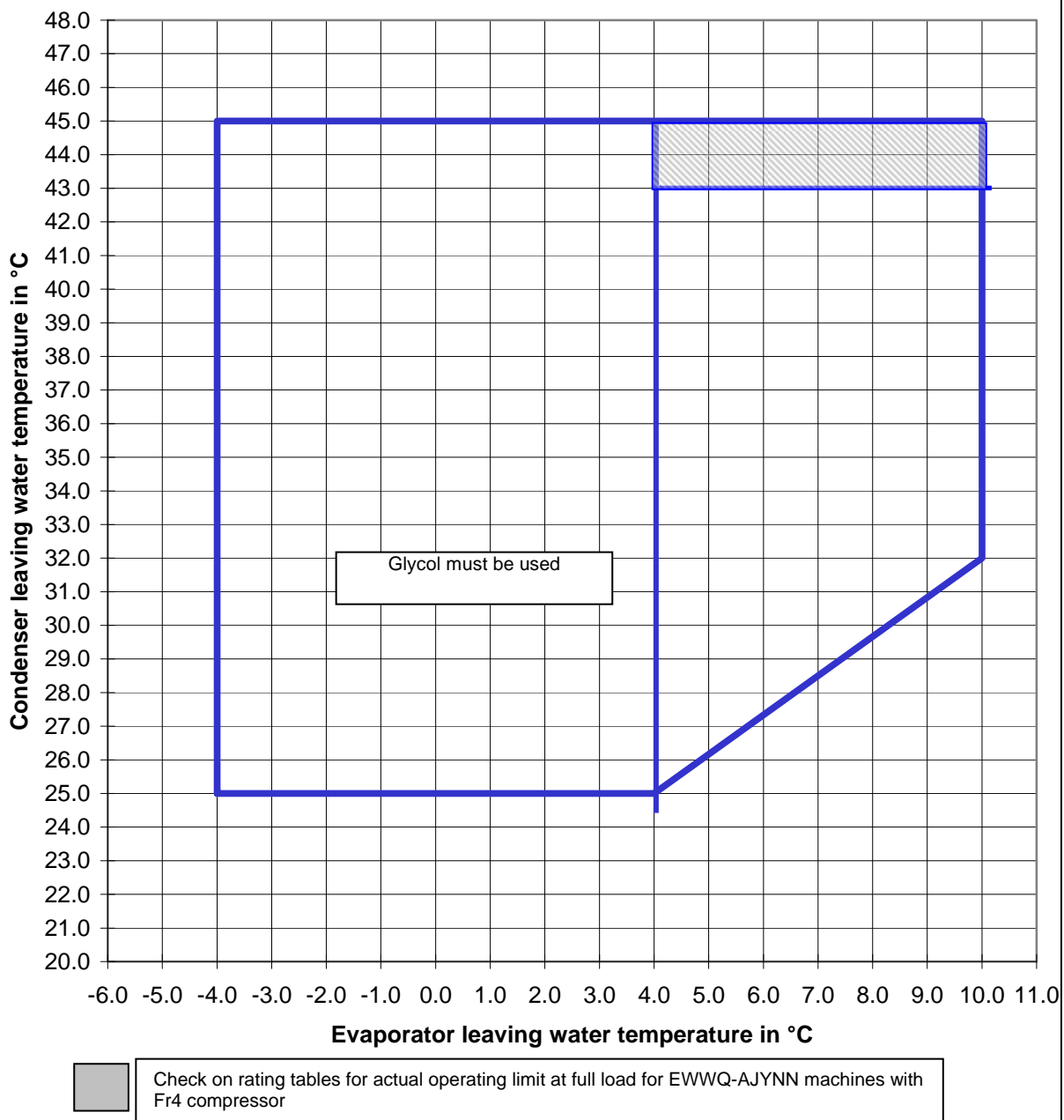
## Operation

Operation is allowed within the limits mentioned in the following diagrams.

### ▲ ATTENTION

Operation outside the mentioned limits may damage the unit.  
In case of doubt, contact the manufacturer.

### Operating limits - EWWQ - AJYNN / EWWQ - AJYNN/A



**Fig. 1 – Operating limits**

# Mechanical Installation

---

## Shipping

The stability of the machine during shipping must be ensured. If the machine is shipped with a wooden cross-plank on its base, the cross-plank must be removed only after the final destination has been reached.

## Responsibility

The manufacturer declines all responsibility, present and future, for any damage to persons, animals or property caused by negligence of operators failing to follow the installation and maintenance instructions in this manual.

All safety equipment must be regularly and periodically checked in accordance with this manual and with local laws and regulations regarding safety and environment protection.

## Safety

The machine must be firmly secured to the ground.

It is essential to observe the following instructions:

- The machine can only be lifted using the lifting points on the base of the machine itself. These are the only points that can support the entire weight of the unit.
- Do not allow unauthorised and/or unqualified personnel to access the machine.
- It is forbidden to access the electrical components without having opened the machine's general disconnecting switch and switched off the power supply.
- It is forbidden to access the electrical components without using an insulating platform. Do not access the electrical components if water and/or moisture are present.
- All operations on the refrigerant circuit and on components under pressure must be carried out by qualified personnel only.
- Replacement of a compressor or addition of lubricating oil must be carried out by qualified personnel only.
- Sharp edges can cause wounds. Avoid direct contact.
- Avoid introducing solid bodies into the water pipes while the machine is connected to the system.
- A mechanical filter must be installed on the water pipe connected to the heat exchanger inlet.
- The machine is supplied with safety valves, that are installed on both the high and the low pressure sides of the refrigerant circuit.

In case of sudden stop of the unit, follow the instructions on the **Control Panel Operating Manual** which is part of the on-board documentation delivered to the end user with this manual.

It is recommended to perform installation and maintenance with other people. In case of accidental injury or unease, it is necessary to:

- keep calm
- press the alarm button if present in the installation site
- move the injured person in a warm place far from the unit and in rest position
- contact immediately emergency rescue personnel of the building or if the Health Emergency Service
- wait without leaving the injured person alone until the rescue operators come
- give all necessary information to the the rescue operators

### **WARNING**

Before carrying out any operation on the machine, please read this instruction and operating manual carefully. Installation and maintenance must be carried out only by qualified personnel that is familiar with the provisions of law and local regulations and has been trained properly or has experience with this type of equipment.

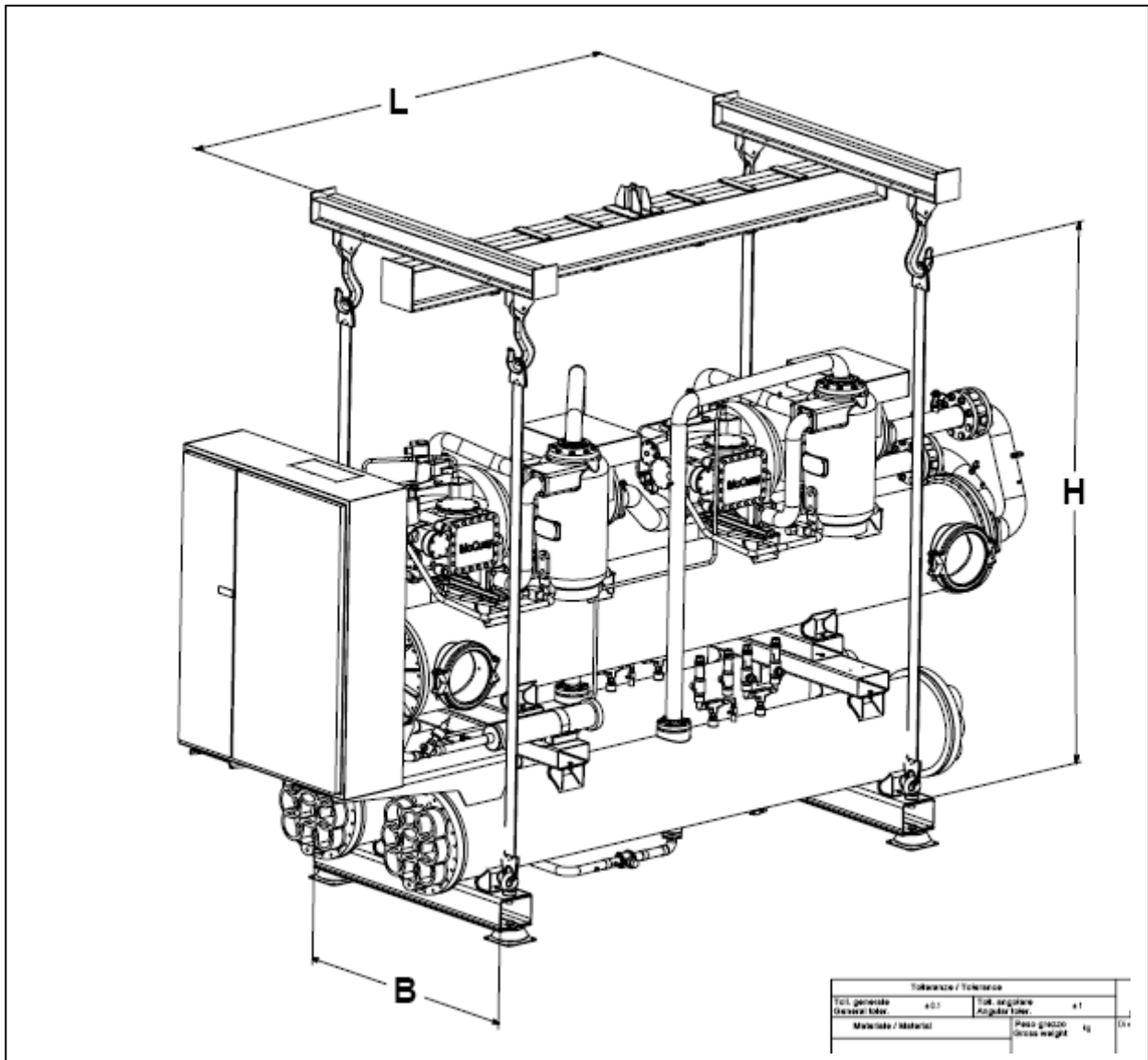
### **WARNING**

Avoid installing the machine in a place that could be dangerous during maintenance operations, such as (but not only) platforms without parapets or railings or areas not complying with the clearance requirements.

## Moving and lifting

Avoid bumping and/or jolting during unloading from the lorry and moving the machine. Do not push or pull the machine from any part other than the base frame. Secure the machine inside the lorry to prevent it from moving and causing damage to the panels and to the base frame. Do not allow any part of the machine to fall during transportation and/or unloading, as this could cause serious damage.

All units of the series are supplied with four lifting points. Only these points may be used for lifting the unit, as shown in figure 2.



**Fig. 2 - Lifting the unit**

**⚠ WARNING**

Both the lifting ropes and the spacing bar and/or scales must be strong enough to support the machine safely. Please check the unit's weight on the machine's nameplate. The weights shown in the "Technical data" tables in the "General Information" chapter refer to standard units. Some specific machines might have accessories that increase their overall weight (heat recovery, etc.)

**⚠ WARNING**

The machine must be lifted with the utmost attention and care. Avoid jolting when lifting and lift the machine very slowly, keeping it perfectly level.

**Positioning and assembly**

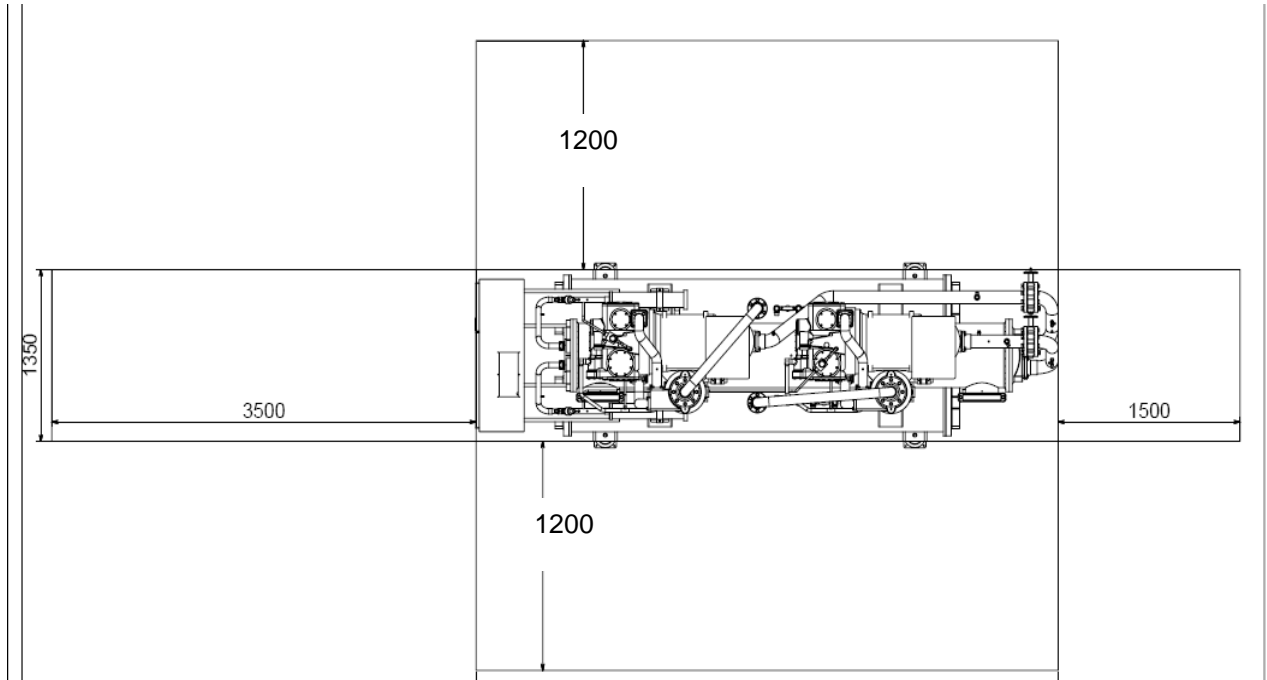
All units are designed for installation indoors. The machine must be installed on a robust and perfectly level foundation; should the machine be installed on balconies or roofs, it might be necessary to use weight distribution beams. For installation on the ground, prepare a strong cement base that is at least 250 mm wider and longer than the machine. Also, this base must be strong enough to support the weight of the machine as stated in the technical specifications. If the machine is installed in places that are easily accessible to people and animals, it is advisable to install protection gratings for the compressor section.

To ensure the best possible performance on the installation site, the following precautions and instructions must be followed:

- Make sure to provide a strong and solid foundation to reduce noise and vibration as much as possible.
- The water in the system must be particularly clean and all traces of oil or rust must be removed. A mechanical water filter must be installed on the machine's inlet piping.

### Minimum space requirements

Every side of the machine must be accessible for all post-installation maintenance activities. Figure 3 shows the minimum space necessary.



**Fig. 3 – Minimum clearance requirements for machine maintenance**

### Ventilation

The temperature of the room where the unit is placed should be always maintained between 0°C and 40°C.

### Sound protection

When sound levels require special control, great care must be exercised to isolate the machine from its base by appropriately applying anti-vibration elements (supplied as an option). Flexible joints must be installed on the water connections, as well.

### Water piping

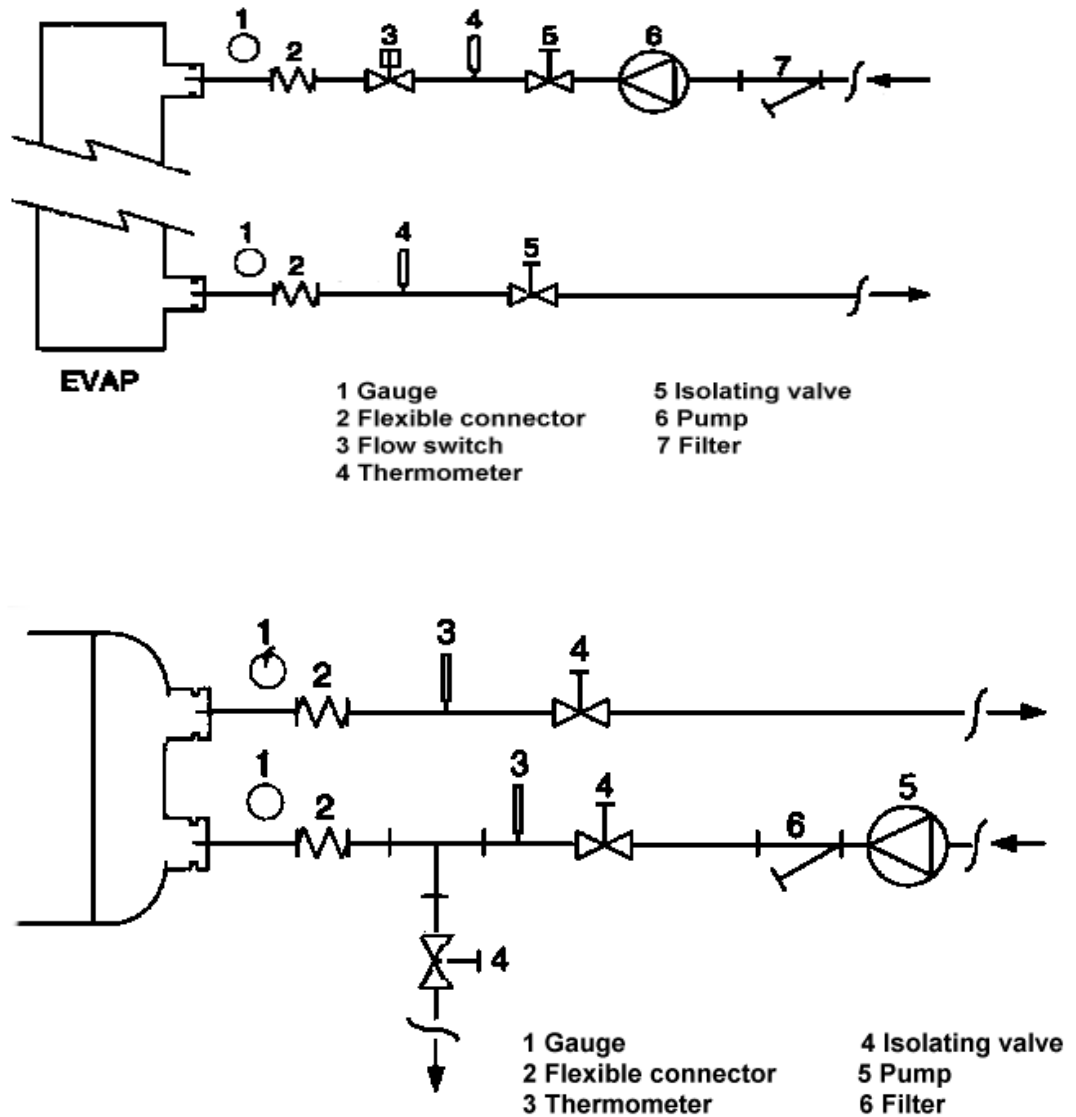
Piping must be designed with the lowest number of elbows and the lowest number of vertical changes of direction. In this way, installation costs are reduced considerably and system performance is improved.

The water system should have:

1. Anti-vibration mountings in order to reduce transmission of vibrations to the underlying structure.
2. Isolating valves to isolate the machine from the water system during service.
3. Manual or automatic air venting device at the system's highest point; drain device at the system's lowest point. Neither the evaporator nor the heat recovery device must be positioned at the system's highest point.
4. A suitable device that can maintain the water system under pressure (expansion tank, etc.)
5. Water temperature and pressure indicators on the machine to assist the operator during service and maintenance.
6. A filter or device which can remove foreign particles from the water before it enters the pump (in order to prevent cavitation, please consult the pump manufacturer for the recommended type of filter ). The use of a filter prolongs the life of the pump and helps keep the water system in a better condition.
7. Another filter must be installed on the machine inlet water pipe, near the evaporator and heat recovery (if installed). The filter prevents solid particles from entering the heat exchanger, as they could damage it or reduce its heat exchanging capacity.
8. The heat recovery device must be emptied of water during the winter season, unless an ethylenic glycol mixture in appropriate percentage is added to the water circuit.

9. If the machine is intended to replace of another, the entire water system must be emptied and cleaned before the new unit is installed. Regular tests and proper chemical treatment of water are recommended before starting up the new machine.
10. In the event that glycol is added to the water system as anti-freeze protection, pay attention to the fact that suction pressure will be lower, the machine's performance will be lower and water pressure drops will be greater. All machine-protection systems, such as anti-freeze, and low-pressure protection will need to be readjusted.

Before insulating water piping, check that there are no leaks.



**Fig. 4 – Water piping connection for heat recovery exchangers**

## ▲ ATTENTION

Install a mechanical filter on the inlet to each heat exchanger. Failure to install a mechanical filter allows solid particles and/or welding slag to enter the exchanger. Installation of a filter with a mesh size not exceeding 0.5 mm in diameter is advised.

The manufacturer cannot be held responsible for any damage to exchangers ensuing from the lack of a mechanical filter.

### Water treatment

Before putting the machine into operation, clean the water circuit. Dirt, scaling, corrosion residue and other foreign material can accumulate inside the heat exchanger and reduce its heat exchanging capacity. Pressure drops can increase as well, thus reducing water flow. Proper water treatment therefore reduces the risk of corrosion, erosion, scaling, etc. The most appropriate water treatment must be determined locally, according to the type of system and local characteristics of the process water.

The manufacturer is not responsible for damage to or malfunctioning of equipment caused by failure to treat water or by improperly treated water.

**Table 11 – Acceptable water quality limits**

PH (25°C)	6.8÷8.0	Total hardness (mg CaCO <sub>3</sub> / l)	< 200
Electricity conductivity μS/cm (25°C)	<800	Iron (mg Fe / l)	< 1.0
Chloride ion (mg Cl <sup>-</sup> / l)	<200	Sulphide ion (mg S <sup>2-</sup> / l)	None
Sulphate ion (mg SO <sub>4</sub> <sup>2-</sup> / l)	<200	Ammonium ion (mg NH <sub>4</sub> <sup>+</sup> / l)	< 1.0
Alkalinity (mg CaCO <sub>3</sub> / l)	<100	Silica (mg SiO <sub>2</sub> / l)	< 50

### Evaporator and exchangers anti-freeze protection

Two or more of below protection methods should be considered when designing the system as a whole:

1. Continuous water flow circulation inside piping and exchangers.
2. Addition of an appropriate amount of glycol inside the water circuit.
3. Additional heat insulation and heating of exposed piping.
4. Emptying and cleaning of the heat exchanger during the winter season.

It is the responsibility of the installer and/or local maintenance personnel to ensure that two or more of the described anti-freeze methods are used. Make sure that appropriate anti-freeze protection is maintained at all times. Failure to follow the instructions above could result in damage to some of the machine's components. Damage caused by freezing is not covered by the warranty.

### Installing the flow switch

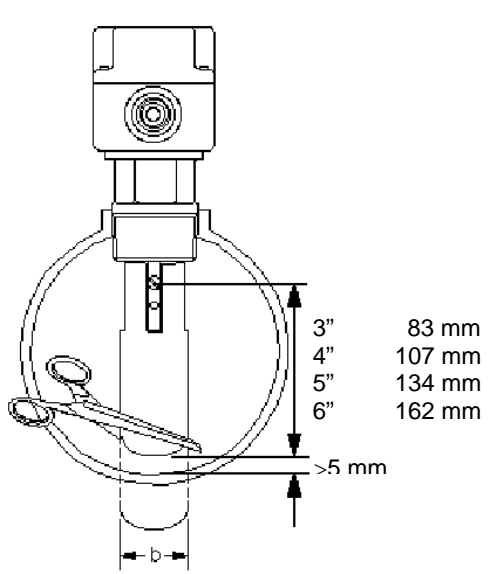
To ensure sufficient water flow through the evaporator, it is essential that a flow switch be installed on the water circuit. The flow switch can be installed either on the inlet or outlet water piping. The purpose of the flow switch is to stop the machine in the event of interrupted water flow, thus protecting the evaporator from freezing.

A flow switch specifically gauged for this purpose, with identification code 131035072, is available as an option.

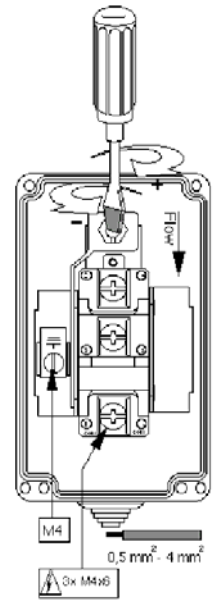
This paddle-type flow switch is suitable for heavy-duty outdoor applications (IP67) for pipe diameters in the range of 1" to 6".

The flow switch is provided with a clean contact which must be electrically connected to the terminals of the terminal board (check the machine's wiring diagram for further information).

For further information regarding device installation and settings, please read the instruction leaflet in the device box.



For 3" - 6" piping  
Use paddle b = 29 mm



Adjusting the flow switch's trigger sensitivity

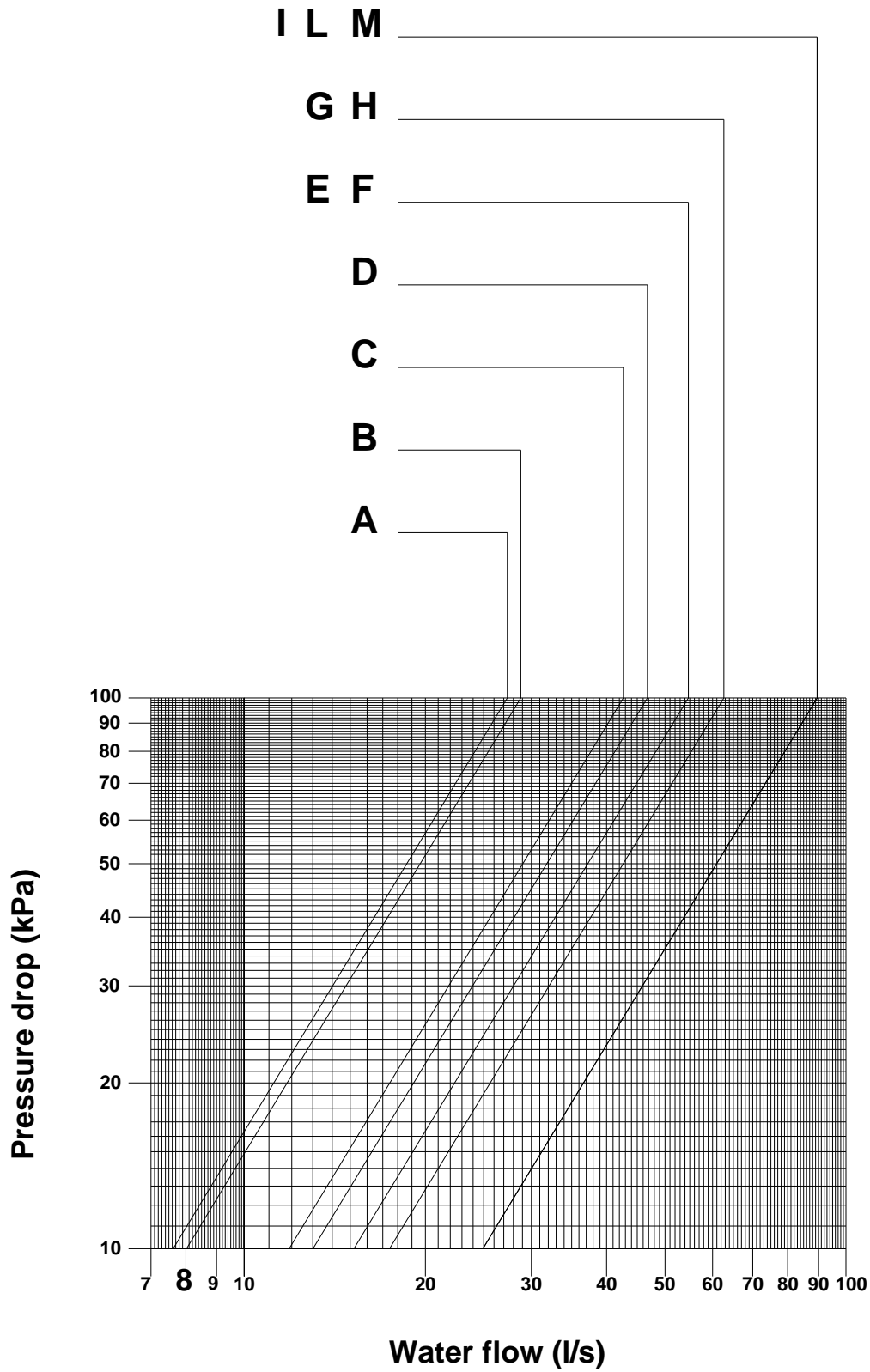
**Fig. 5 - Adjusting the safety flow switch**

**Refrigerating circuit safety valves**

Each system comes with safety valves that are installed on each circuit, both on the evaporator and on the condenser. The purpose of the valves is to release the refrigerant inside the refrigerant circuit in the event of certain malfunctions.

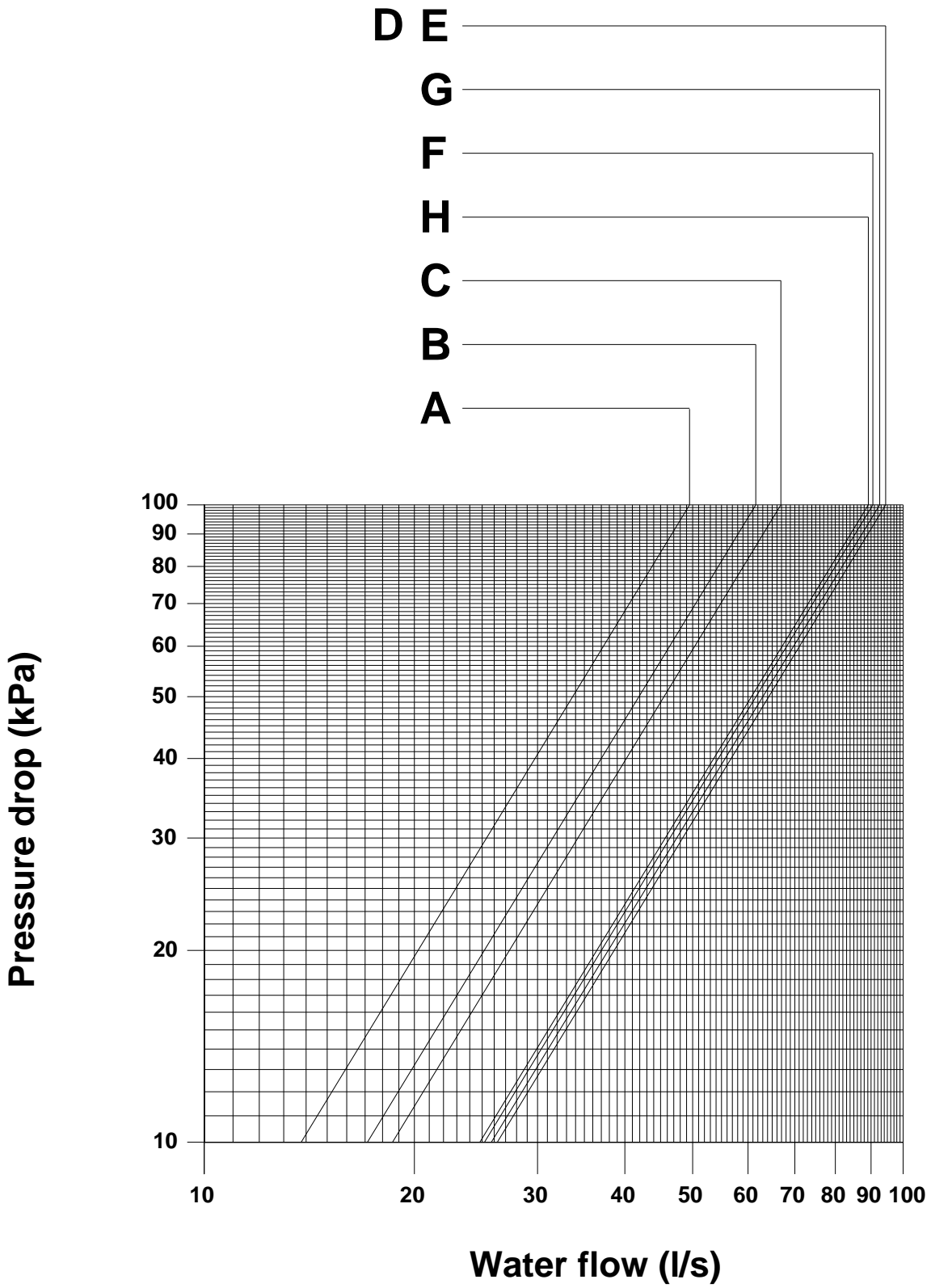


Fig. 6 – Evaporator pressure drop – EWWQ - AJYNN



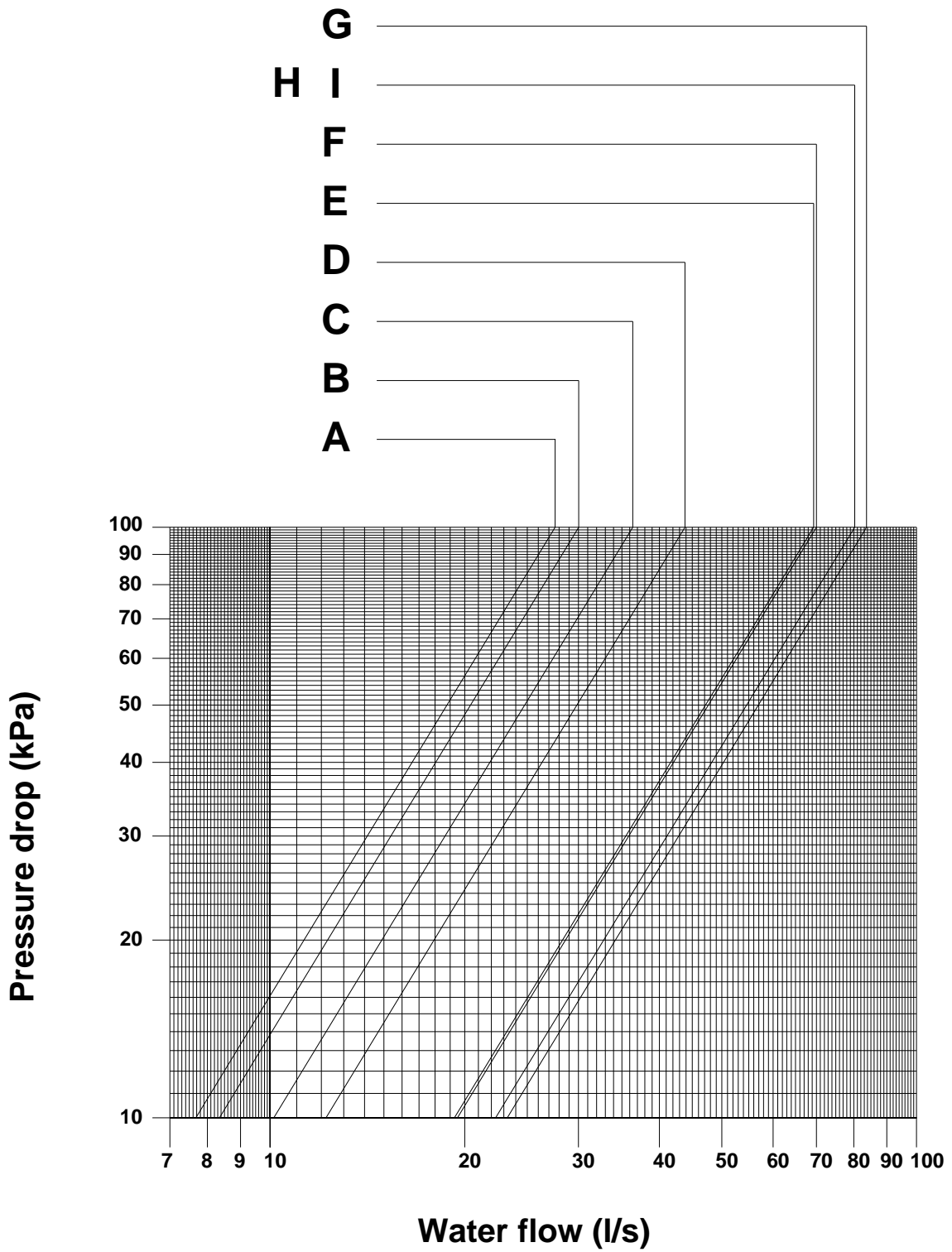
A	400	G	C10
B	480	H	C12
C	600	I	C13
D	650	L	C14
E	800	M	C15
F	900		

Fig. 7 – Evaporator pressure drop – EWWQ - AJYNN



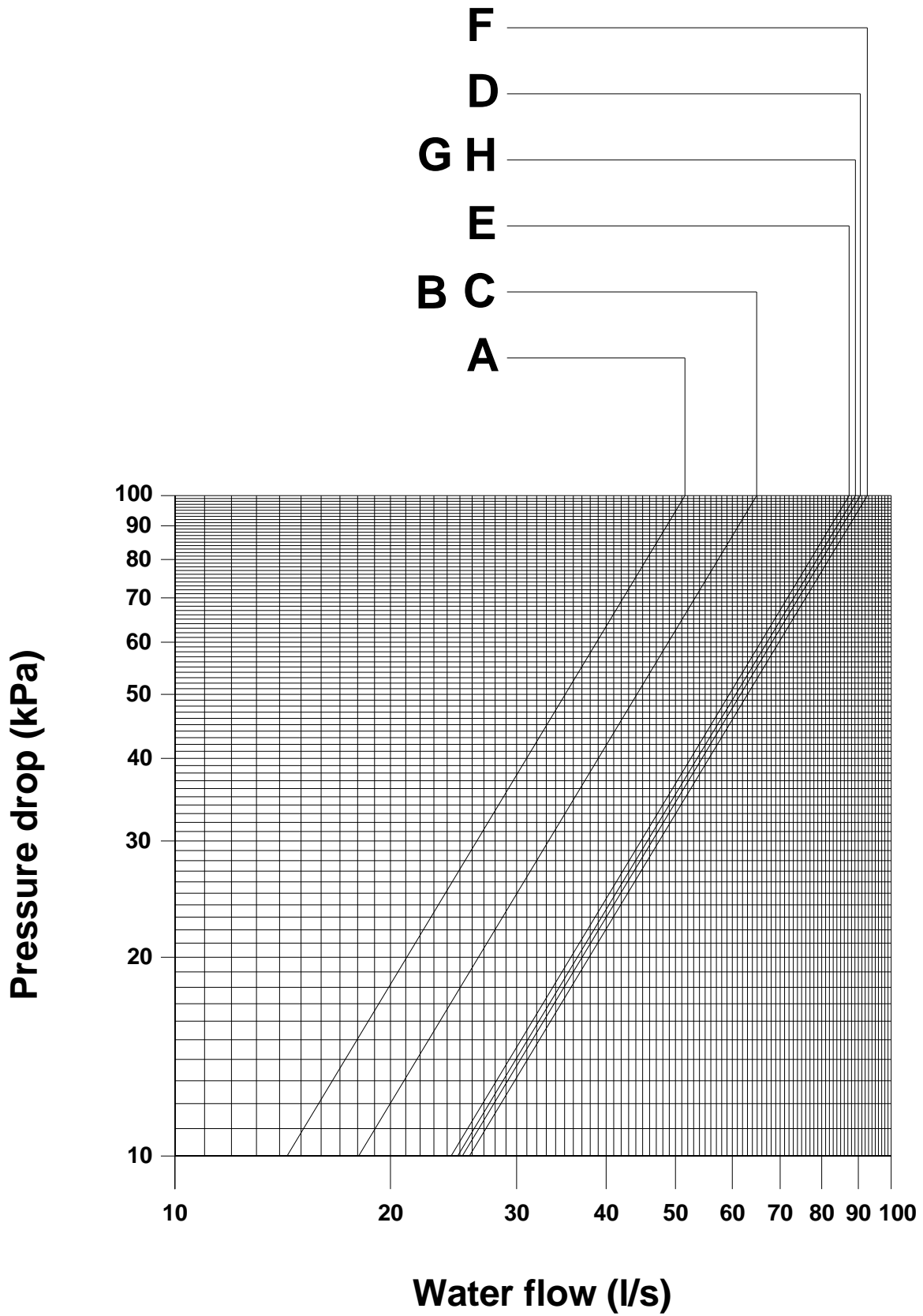
A.	750	E.	C17
B.	850	F.	C18
C.	C11	G.	C19
D.	C16	H.	C20

Fig. 8 – Evaporator pressure drop - EWWQ – AJYNN/A



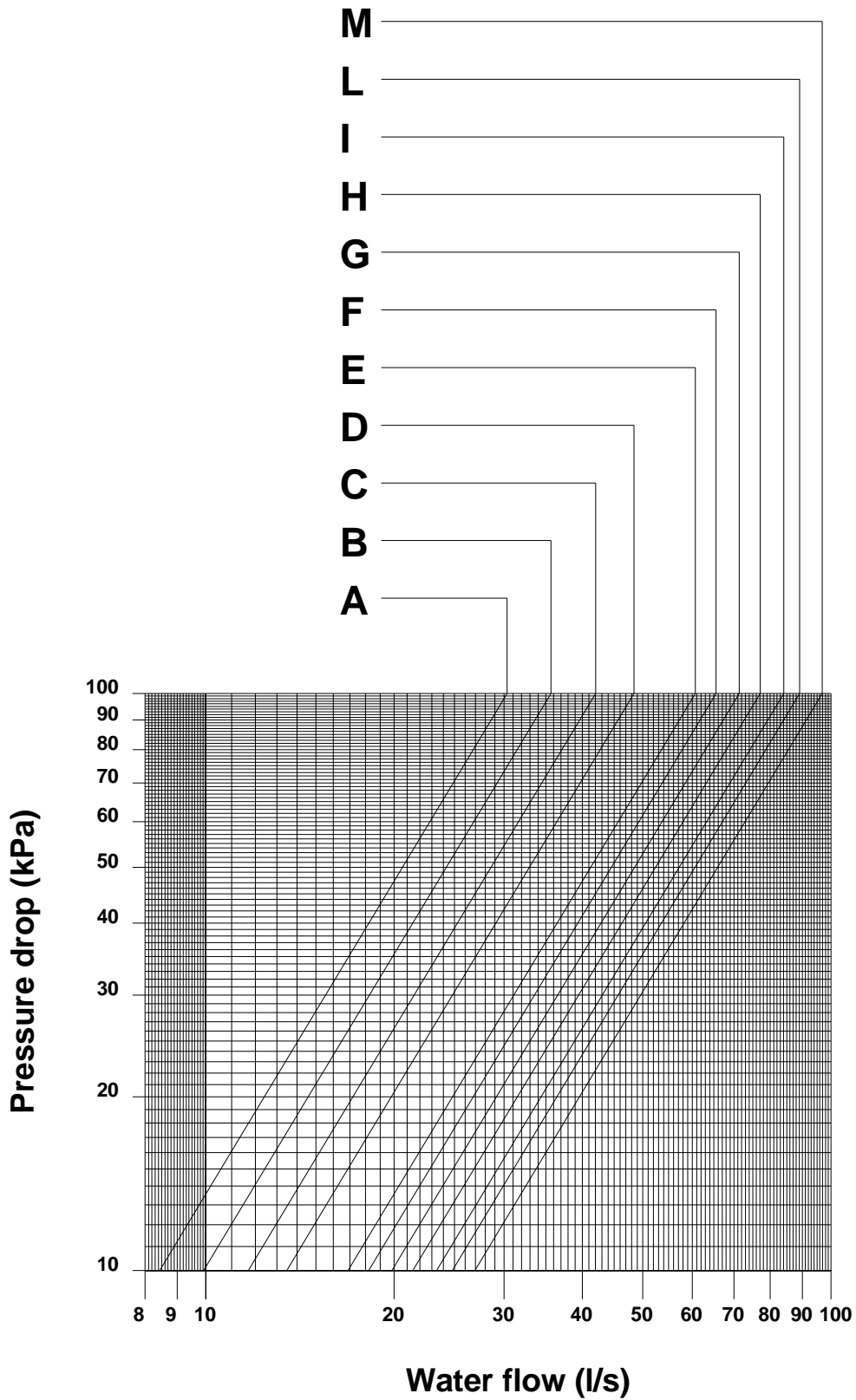
A.	440	F.	C12
B.	550	G.	C13
C.	650	H.	C14
D.	750	I.	C15
E.	C10		

Fig. 9 – Evaporator pressure drop - EWWQ - AJYNN /A



A.	800	E.	C18
B.	950	F.	C19
C.	C11	G.	C20
D.	C16	H.	C22

**Fig. 10 – Condenser pressure drop - EWWQ - AJYNN**



A.	400	G.	C10
B.	480	H.	C12
C.	600	I.	C13
D.	650	L.	C14
E.	800	M.	C15
F.	900		

Fig. 11 – Condenser pressure drop - EWWQ - AJYNN

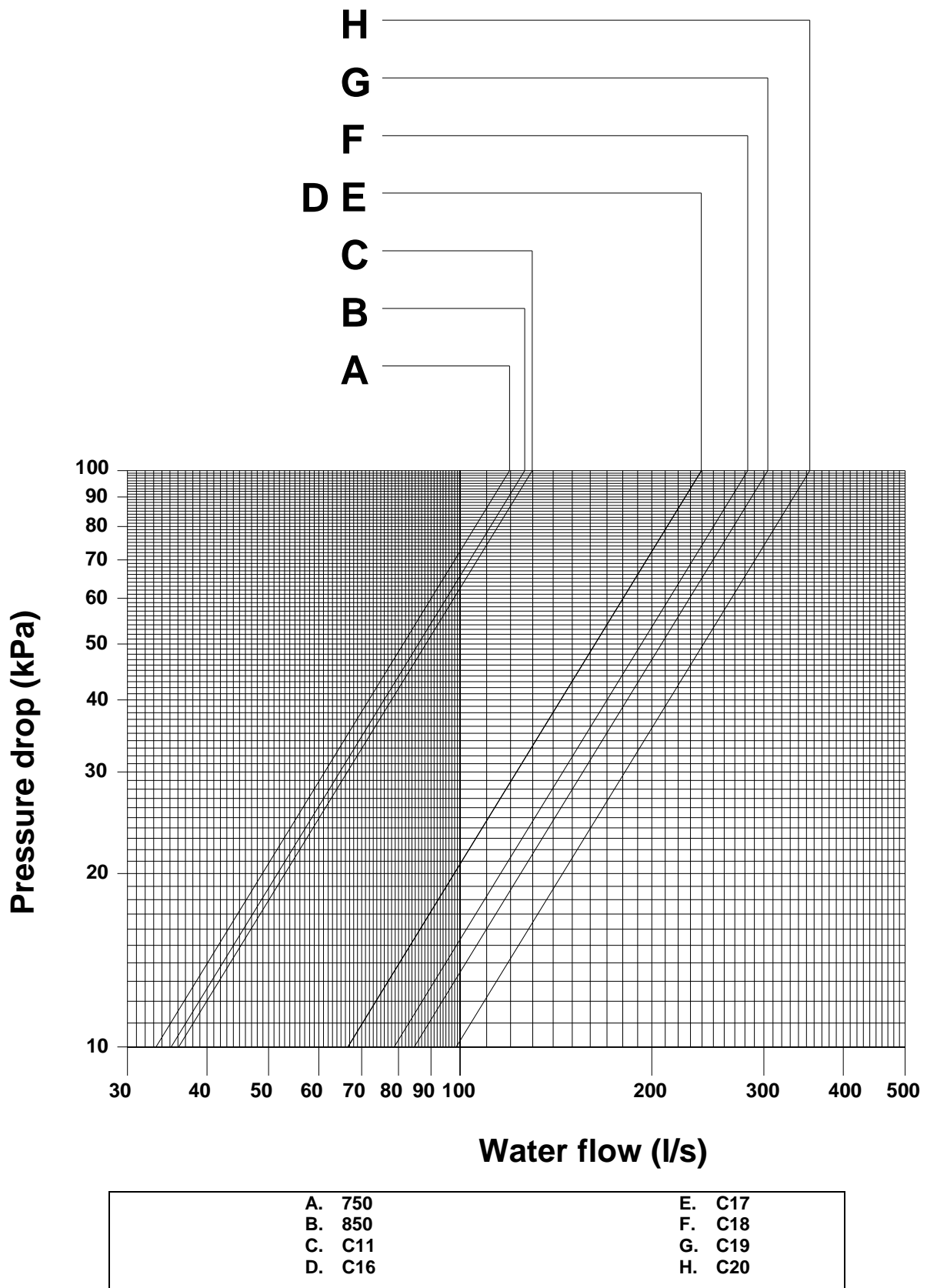


Fig. 12 – Condenser pressure drop - EWWQ – AJYNN/A

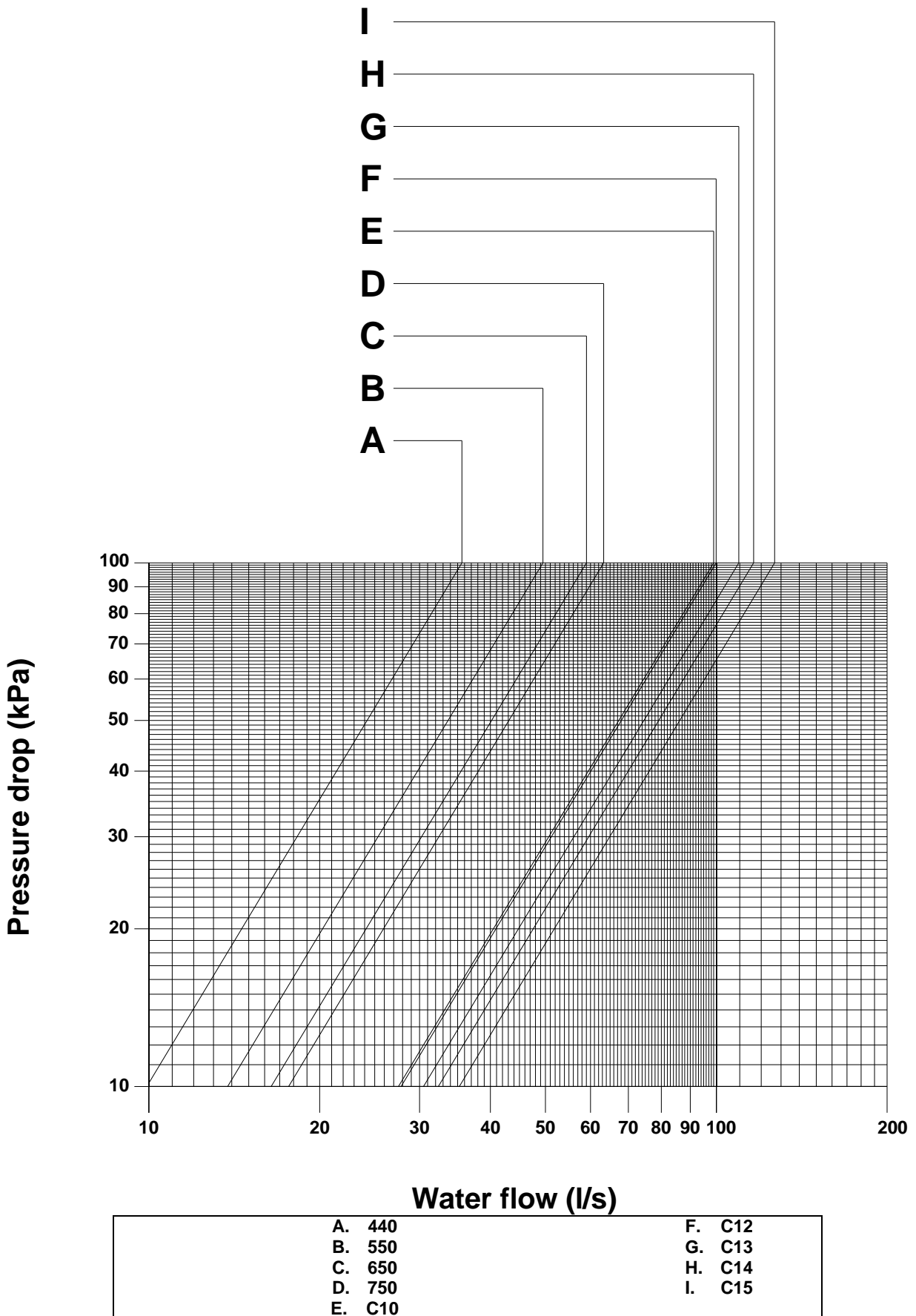
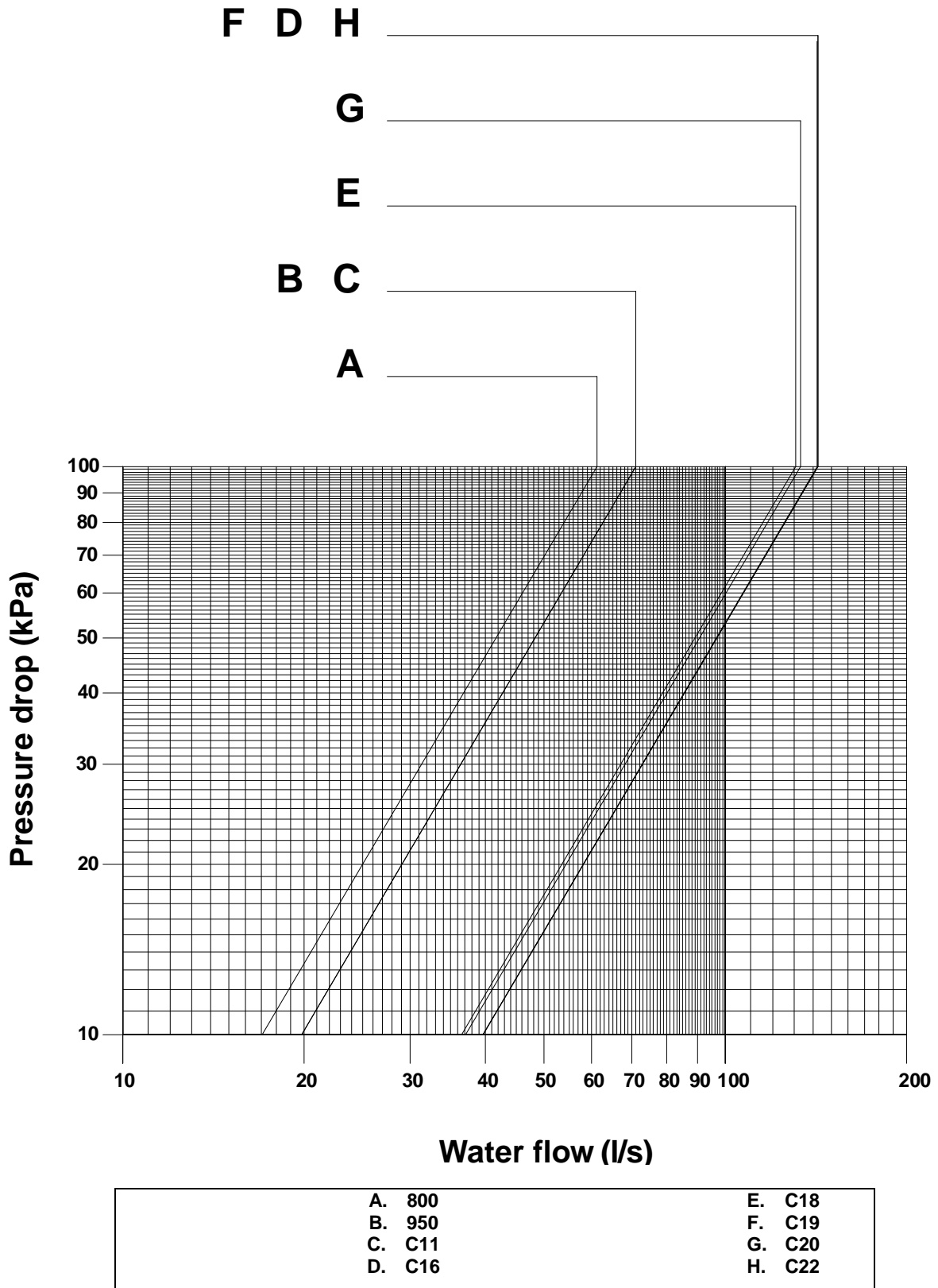
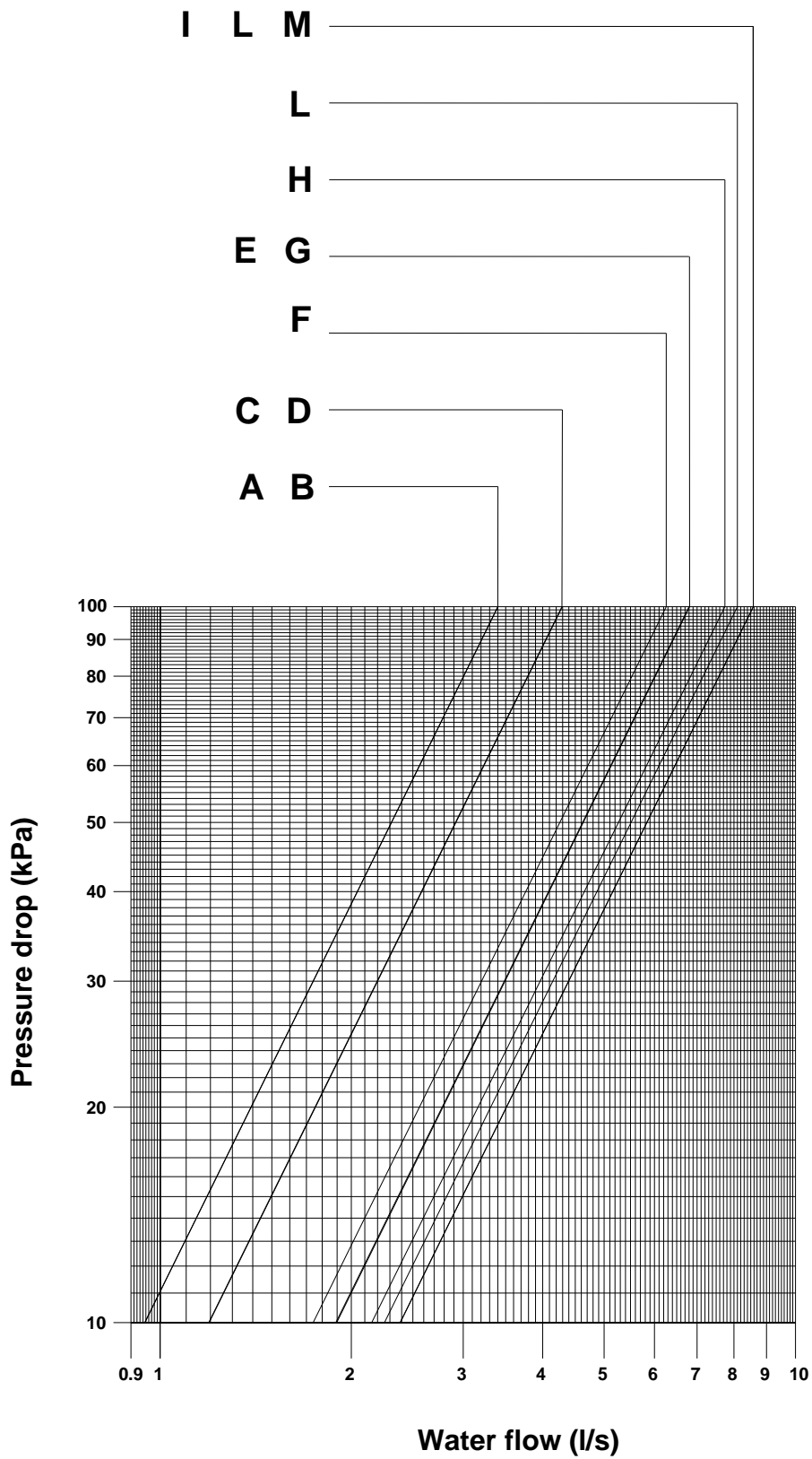


Fig. 13 – Condenser pressure drop - EWWQ – AJYNN/A



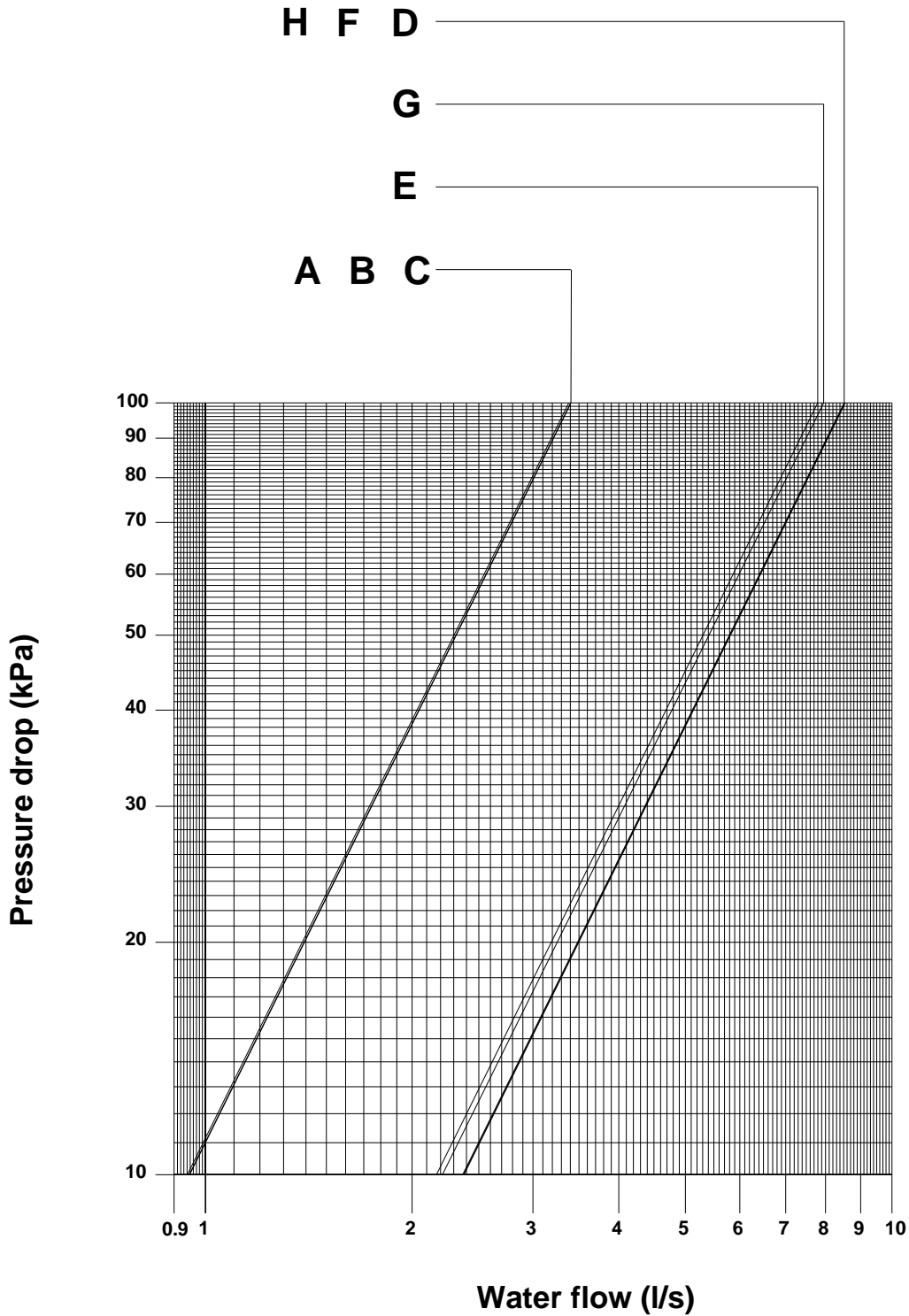


**Fig. 14 – Partial heat recovery pressure drop - EWWQ – AJYNN**



A.	400	G.	C10
B.	480	H.	C12
C.	600	I.	C13
D.	650	L.	C14
E.	800	M.	C15
F.	900		

Fig. 15 – Partial heat recovery pressure drop - EWWQ – AJYNN



A. 750	E. C17
B. 850	F. C18
C. C11	G. C19
D. C16	H. C20

Fig. 16 – Partial heat recovery pressure drop - EWWQ – AJYNN/A

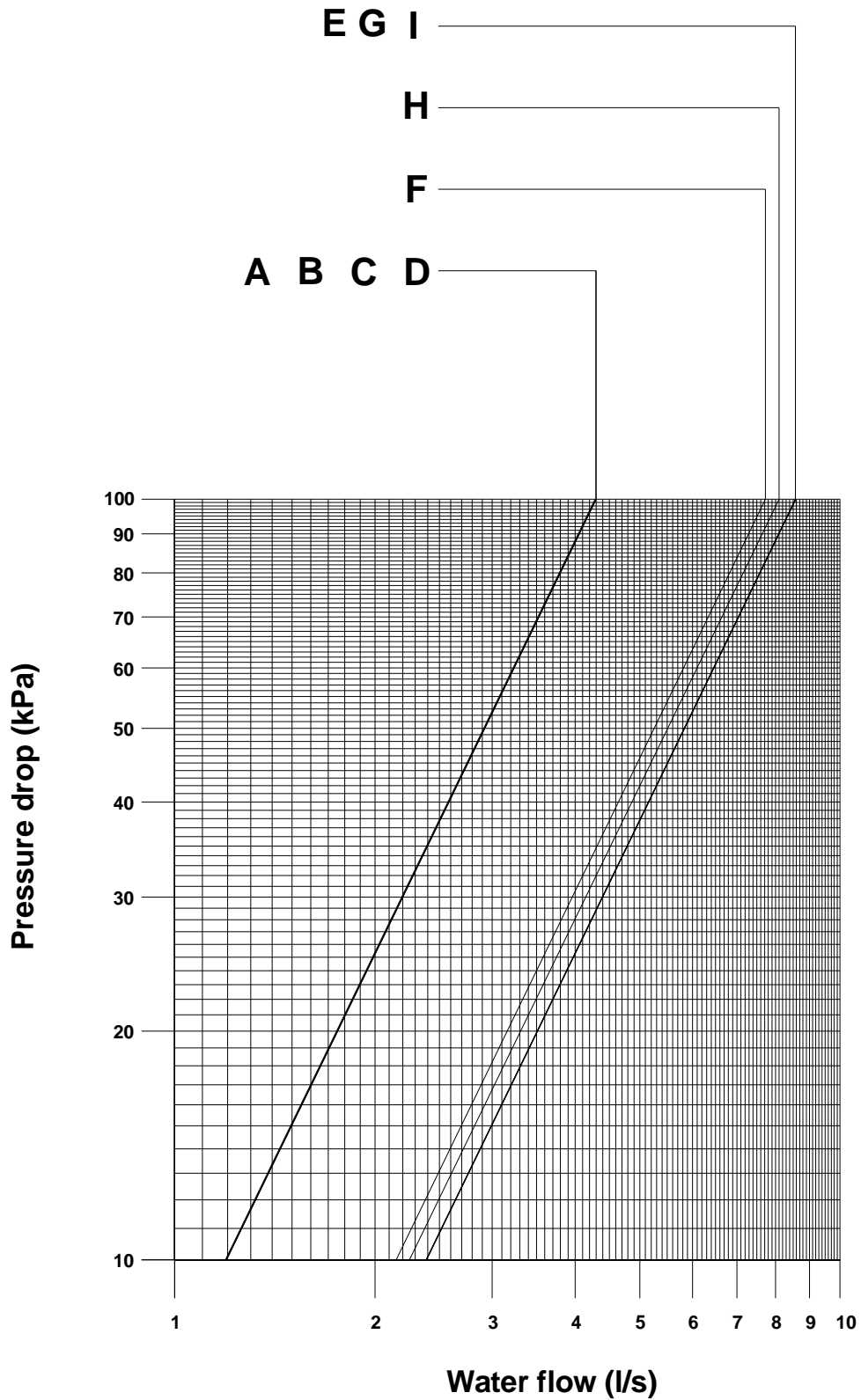
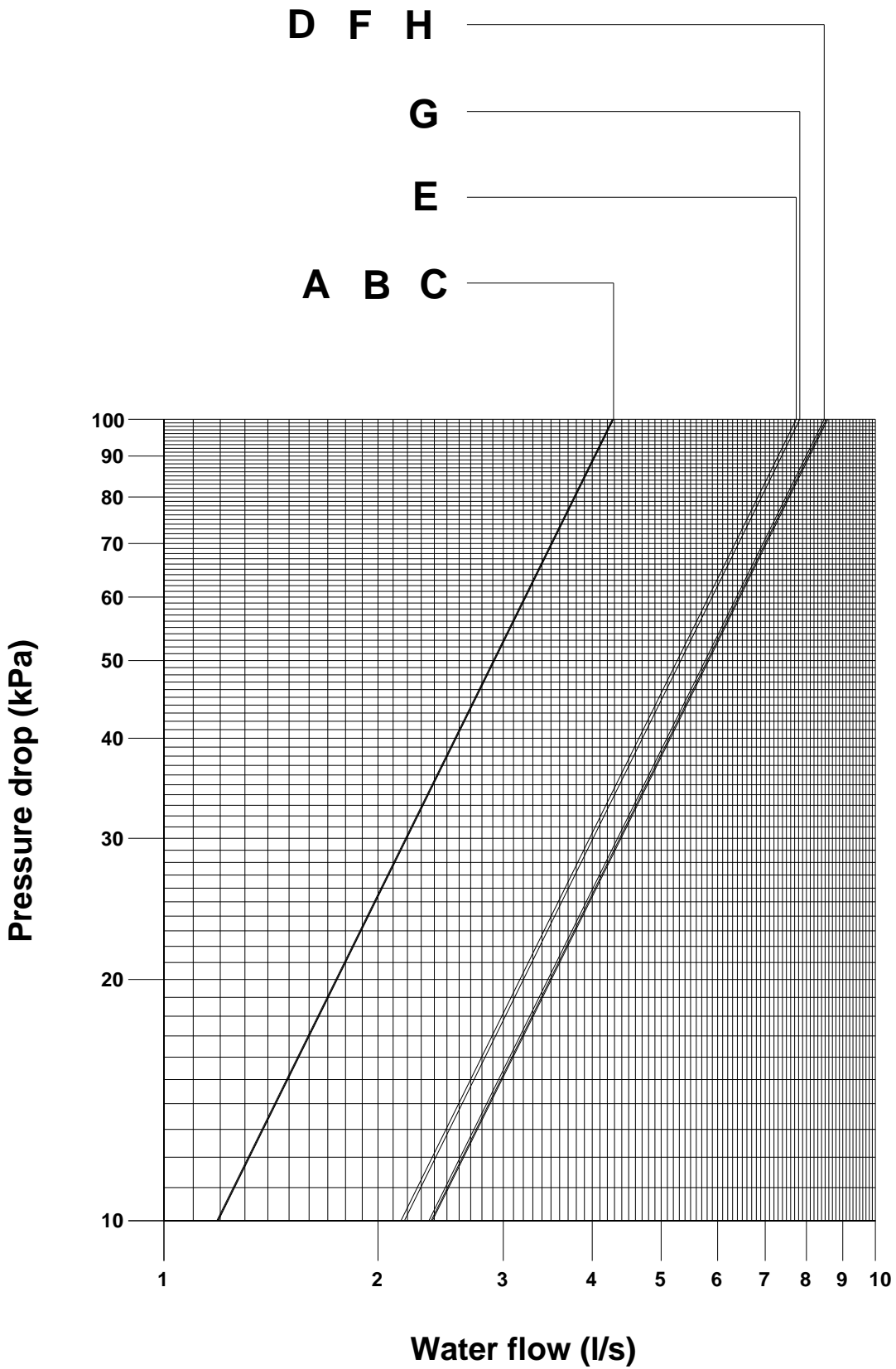


Fig. 17 – Partial heat recovery pressure drop - EWWQ – AJYNN/A



A. 800	E. C18
B. 950	F. C19
C. C11	G. C20
D. C16	H. C22

# Electrical Installation

---

## General specifications

### CAUTION

All electrical connections to the machine must be carried out in compliance with laws and regulations in force. All installation, operating and maintenance activities must be carried out by qualified personnel. Please refer to the specific wiring diagram for the machine that you have purchased and which was sent with the unit. Should the wiring diagram not appear on the machine or should it have been lost, please contact your dealer who will provide for a copy to be forwarded.

### CAUTION

Use copper conductors only. Use of conductors in any material other than copper could cause overheating or corrosion at the connection points and damage the unit. To avoid interference, all control wires must be installed separately from the power cables. Use separate electrical conduits for this purpose.

### CAUTION

Before servicing the machine in any way, open the general disconnecting switch on the machine's main power supply. When the machine is off but the disconnect switch is in the closed position, unused circuits are live, as well. Never open the terminal board box of the compressors before having opened the unit's general disconnecting switch.

### CAUTION

Concurrence of single-phase and three-phase charges and unbalance between phases can cause leakages towards ground of up to 150 mA during the normal operation of the units of the series.

If the unit includes devices that cause superior harmonics (such as VFD and phase cut), the leakage towards ground could increase to very high values (about 2 Ampere).

The protections for the power supply system must be designed in accordance with the above mentioned values.

**Table 12 – Electrical data EWWQ-AJYNN Unit**

Size of unit	Unit					Compressors						Control		
	Max. current for wires sizing	Max. startup current (1)	Power factor (2)	Size of disconnecting switch	Short-circuit current Icc	Number of compressors	Max. current of compressors Circ.1/ Circ.2 (3)		Peak current of compressors Circ.1/ Circ.2		Size of type gG NH0/NH1 compressor fuses Circ.1/ Circ.2		VA	A
	A	A		A	kA		A	A	A	A	A	A		
400	197	455	0.85	400 A	25	1	189		455		250		500	4
480	235	455	0.87	400 A	25	1	225		455		250		500	4
600	286	455	0.89	400 A	25	1	274		455		315		500	4
650	324	455	0.90	400 A	25	1	238		455		355		500	4
750	357	656	0.89	630 A	25	1	325		656		355		500	4
850	394	610	0.85	630 A	25	2	189	189	455	455	250	250	500	4
C11	419	656	0.90	630 A	25	1	388		656		500		500	4
800	432	638	0.86	630 A	25	2	189	225	455	455	250	250	500	4
900	470	638	0.87	630 A	25	2	225	225	455	455	250	250	500	4
C10	489	656	0.92	630 A	25	1	458		656		630		500	4
C12	522	676	0.88	630 A	25	2	225	274	455	455	250	315	500	4
C13	574	676	0.89	800 A	25	2	274	274	455	455	315	315	500	4
C14	611	705	0.90	800 A	25	2	274	310	455	455	315	355	500	4
C15	648	705	0.90	800 A	25	2	310	310	455	455	355	355	500	4
C16	715	933	0.89	800 A	25	2	325	325	656	656	355	355	500	4
C17	778	984	0.90	800 A	25	2	325	388	656	656	355	500	500	4
C18	840	984	0.90	1000 A	25	2	388	388	656	656	500	500	500	4
C19	906	1035	0.91	1000 A	25	2	388	458	656	656	500	630	500	4
C20	975	1035	0.92	1000 A	25	2	458	458	656	656	630	630	500	4

(1) Start-up current of the biggest compressor + current at 75% of the other compressors at maximum conditions

(2) Power factor of compressors under nominal conditions (12/7°C – 30/35°C – 400V)

(3) FLA compressors

**Table 13 – Electrical data EWWQ – AJYNN/A Unit**

Size of unit	Unit					Compressors						Control		
	Max. current for wires sizing (1)	Max. startup current (2)	Power factor (3)	Size of disconnecting switch	Short-circuit current I <sub>cc</sub>	Number of compressors	Max. current of compressors		Peak current of compressors		Size of type gG NH0/NH1 compressor fuses		VA	A
	A	A		A	kA		Circ.1/	Circ.2	Circ.1/	Circ.2	A	A		
440	195	455	0.85	400 A	25	1	189		455		250		500	4
550	232	455	0.87	400 A	25	1	225		455		250		500	4
650	282	455	0.89	400 A	25	1	274		455		315		500	4
750	320	455	0.90	400 A	25	1	310		455		355		500	4
800	348	656	0.89	630 A	25	1	325		656		355		500	4
950	414	656	0.90	630 A	25	1	388		656		500		500	4
C10	464	636	0.87	630 A	25	2	225	225	455	455	250	250	500	4
C11	486	656	0.91	630 A	25	1	458		656		630		500	4
C12	514	674	0.88	630 A	25	2	225	274	455	455	250	315	500	4
C13	566	674	0.89	800 A	25	2	274	274	455	455	315	315	500	4
C14	603	702	0.89	800 A	25	2	274	310	455	455	315	355	500	4
C15	639	702	0.90	800 A	25	2	310	310	455	455	355	355	500	4
C16	692	925	0.89	800 A	25	2	325	325	656	656	355	355	500	4
C18	758	979	0.89	800 A	25	2	325	388	656	656	355	500	500	4
C19	824	979	0.90	1000 A	25	2	388	388	656	656	500	500	500	4
C20	895	1032	0.91	1000 A	25	2	388	458	656	656	500	630	500	4
C22	965	1032	0.91	1000 A	25	2	458	458	656	656	630	630	500	4

(1) FLA compressors

(2) Start-up current of the biggest compressor + 75% of the other compressor's nominal current

(3) Power factor of compressors under nominal conditions (12/7°C – 30/35°C – 400V)

## Electrical components

All power and interface electrical connections are specified in the wiring diagram that is shipped with the machine. The installer must supply the following components:

- Power supply wires (dedicated conduit)
- Interconnection and interface wires (dedicated conduit)
- Thermal-magnetic circuit breaker of suitable size (please see electrical data).

## Electrical wiring

### Power circuit:

Connect the electrical power supply cables to the terminals of the general circuit breaker on the machine's terminal board. The access panel must have a hole of appropriate diameter for the cable used and its cable gland. A flexible conduit can also be used, containing the three power phases plus earth.

In any case, absolute protection against any water penetrating through the connection point must be ensured.

### Control circuit:

Every machine of the series is supplied with an auxiliary 400/115V control circuit transformer. No additional cable for the control system power supply is thus required.

Only if the optional separate accumulation tank is requested, the electrical anti-freeze resistance must have a separate power supply.

## Electrical heaters

Each circuit has an electrical heater installed in the compressor, whose purpose is to keep the oil warm thus preventing the presence of liquid refrigerant mixed with the oil in the compressor. Obviously, the operation of the electrical heaters is guaranteed only if there is a constant power supply. If it is not possible to keep the machine powered when inactive during winter, apply at least two of the procedures described in the "Mechanical Installation" section under the "Anti-freeze protection of evaporator and exchangers".

If the plant uses pumps outside the machine (not supplied with the unit), the power line of each pump must be provided with a magnetothermic switch and a control switch.

## Water pump control

Connect the control contactor coil power supply to terminals 27 and 28 (pump #1) and 401 and 402 (pump 2) located on terminal board M3, and install the contactor on a power supply having the same voltage as the pump contactor coil. The terminals are connected to a clean microprocessor contact.

The microprocessor contact has the following commutation capacity:

Maximum voltage:	250 Vac
Maximum current:	2 A Resistive - 2 A Inductive
Reference standard:	EN 60730-1

The wiring described above allows the microprocessor to manage the water pump automatically. It is good practice to install a clean status contact pump's thermal-magnetic circuit breaker and to connect it in series with the flow switch.

## Alarm relays – Electrical wiring

The machine has a clean-contact digital output that changes state whenever an alarm occurs in one of the refrigerant circuits. Connect this signal to an external visual, sound alarm or to the BMS in order to monitor its operation. See the machine's wiring diagram for wiring.

## Unit On/Off remote control – Electrical wiring

The machine has a digital input that allows remote control. A startup timer, a circuit breaker or a BMS can be connected to this input. Once the contact has been closed, the microprocessor launches the startup sequence by first turning on the water pump and then the compressors. When the contact is opened the microprocessor launches the machine shutdown sequence. The contact must be clean.

## Double Setpoint – Electrical wiring

The Double Setpoint function allows to change over the unit setpoint between two predefined values in the unit controller. An example of an application is ice production during the night and standard operation during the day. Connect a circuit breaker or timer between terminals 5 and 21 of terminal board M3. The contact must be clean.

## External water Setpoint reset – Electrical wiring (Optional)

The machine's local setpoint can be modified by means of an external analogue 4-20 mA signal. Once this function has been enabled, the microprocessor allows to modify the setpoint from the set local value up to a differential of 3°C. 4 mA corresponds to a 0°C differential, 20 mA corresponds to the setpoint plus the maximum differential.

The signal cable must be directly connected to terminals 35 and 36 of the M3 terminal board.

The signal cable must be of the shielded type and must not be laid in the vicinity of the power cables, so as not to induce interference with the electronic controller.



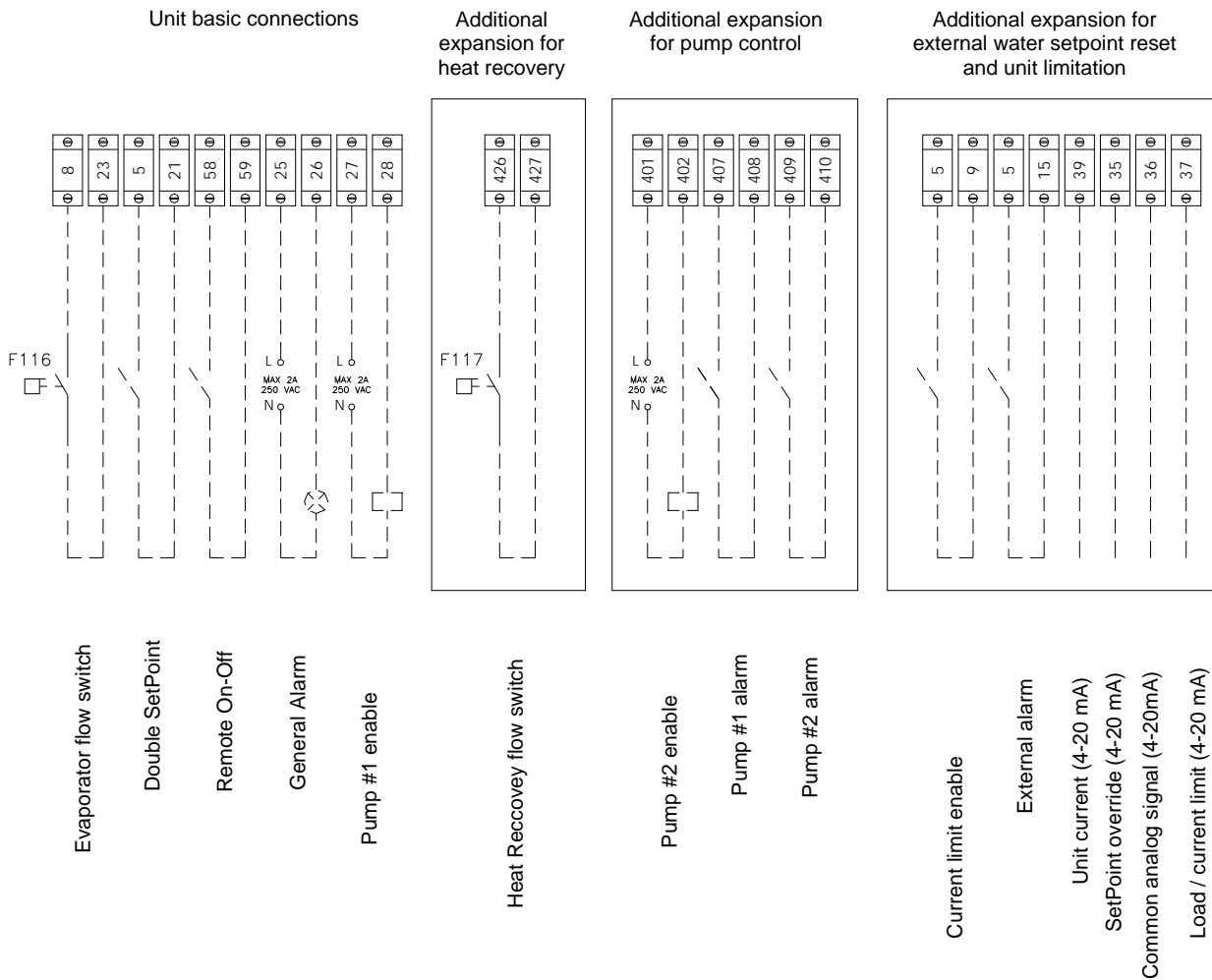
## Unit limitation – Electrical wiring (Optional)

The machine's microprocessor allows to limit the capacity by means of two separate criteria:

- >Load limitation: The load can be varied by means of a 4-20 mA external signal from a BMS. The signal cable must be directly connected to terminals 36 and 37 of the M3 terminal board. The signal cable must be of the shielded type and must not be laid in the vicinity of the power cables, so as not to induce interference with the electronic controller.
- Current limitation: The machine's load can be varied by means of a 4-20 mA external signal from an external device. In this case, current control limits must be set on the microprocessor so that the microprocessor transmits the value of the measured current and limits it. The signal cable must be directly connected to terminals 36 and 37 of the M3 terminal board. The signal cable must be of the shielded type and must not be laid in the vicinity of the power cables, so as not to induce interference with the electronic controller. A digital input allows to enable the current limitation at the desired time. Connect the enabling switch or the timer (clean contact) to terminals 5 and 9.

**Attention: the two options cannot be enabled simultaneously. Setting one function excludes the other.**

**Fig. 18 – User connection to the interface M3 terminal board**



# Operation

---

## Operator's responsibilities

It is important that the operator is appropriately trained and becomes familiar with the system before operating the machine. In addition to reading this manual, the operator must study the microprocessor operating manual and the wiring diagram in order to understand start-up sequence, operation, shutdown sequence and operation of all the safety devices. During the machine's initial start-up phase, a technician authorized by the manufacturer is available to answer any questions and to give instructions as to the correct operating procedures.

The operator is advised to keep a record of operating data for every installed machine. Another record should also be kept of all the periodical maintenance and servicing activities.

If the operator notes abnormal or unusual operating conditions, he is advised to consult the technical service authorized by the manufacturer.

## Description of the machine

This machine, of the water condensation type, is made up of the following main components:

- **Compressor:** The single-screw compressor of the Fr 3200 or Fr4100 series is of the semi-hermetic type and utilises gas from the evaporator to cool the motor and allow optimal operation under any expected load conditions. The oil-injection lubrication system does not require an oil pump as oil flow is ensured by the pressure difference between delivery and suction. In addition to ensuring lubrication of ball bearings, oil injection dynamically seals the screw, thus enabling the compression process.
- **Evaporator:** The direct-expansion shell and tube type evaporator is of ample size in order to ensure optimum efficiency under all load conditions.
- **Condenser:** The shell and tube type condenser has external high efficiency micro fins (C4). The liquid subcooled by the lower part of the tubes not only improves overall efficiency of the machine but also compensates variations in heat load by adapting the refrigerant load to all foreseen operating conditions.
- **Expansion valve:** The machine has a an electronic expansion valve, which is controlled by an electronic device called a Driver that optimises its operation.

## Description of the refrigeration cycle

The low-temperature refrigerant gas from the evaporator is drawn by the compressor through the electric motor, which is cooled by the refrigerant. It is subsequently compressed and during this process the refrigerant mixes with the oil from the oil separator.

The high-pressure oil-refrigerant mixture is introduced into the centrifuge-type high-efficiency oil separator, where the oil is separated from the refrigerant. The oil accumulated on the bottom of the separator is forced by the pressure difference back into the compressor while the oil-free refrigerant is sent to the condenser.

The refrigerant fluid is evenly distributed inside the condenser throughout the volume of the exchanger, and the gas in contact with the tubes is cooled and successively starts to condense.

The condensed fluid at saturation temperature passes through the subcooling section where it loses even more heat, increasing the efficiency of the cycle. The heat taken from the fluid during cooling, condensation and subcooling is exchanged with that of the water passing inside the condenser tubes.

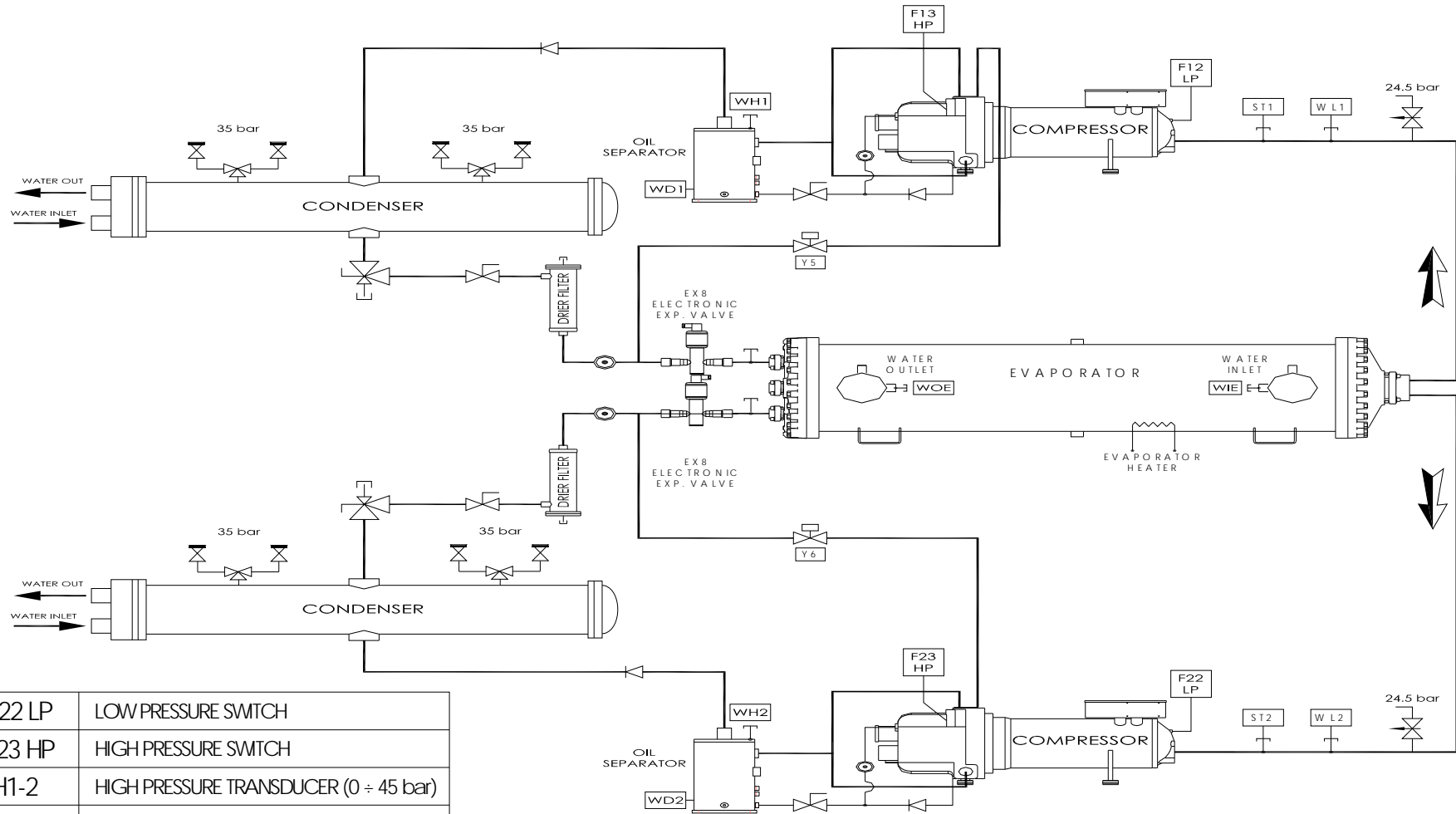
The subcooled fluid flows through the high-efficiency filter dryer and then reaches the expansion element (expansion valve) through which a fall in pressure starts off the expansion process resulting in the vaporisation of part of the refrigerant liquid.

The result at this point is a low-pressure and low-temperature liquid-gas mixture entering the evaporator, where it takes the heat required for vaporisation.

When the refrigerant liquid-vapour is uniformly distributed in the direct expansion evaporator tubes, heat is exchanged with the cooling water, thus reducing the temperature until complete evaporation, followed by superheating.

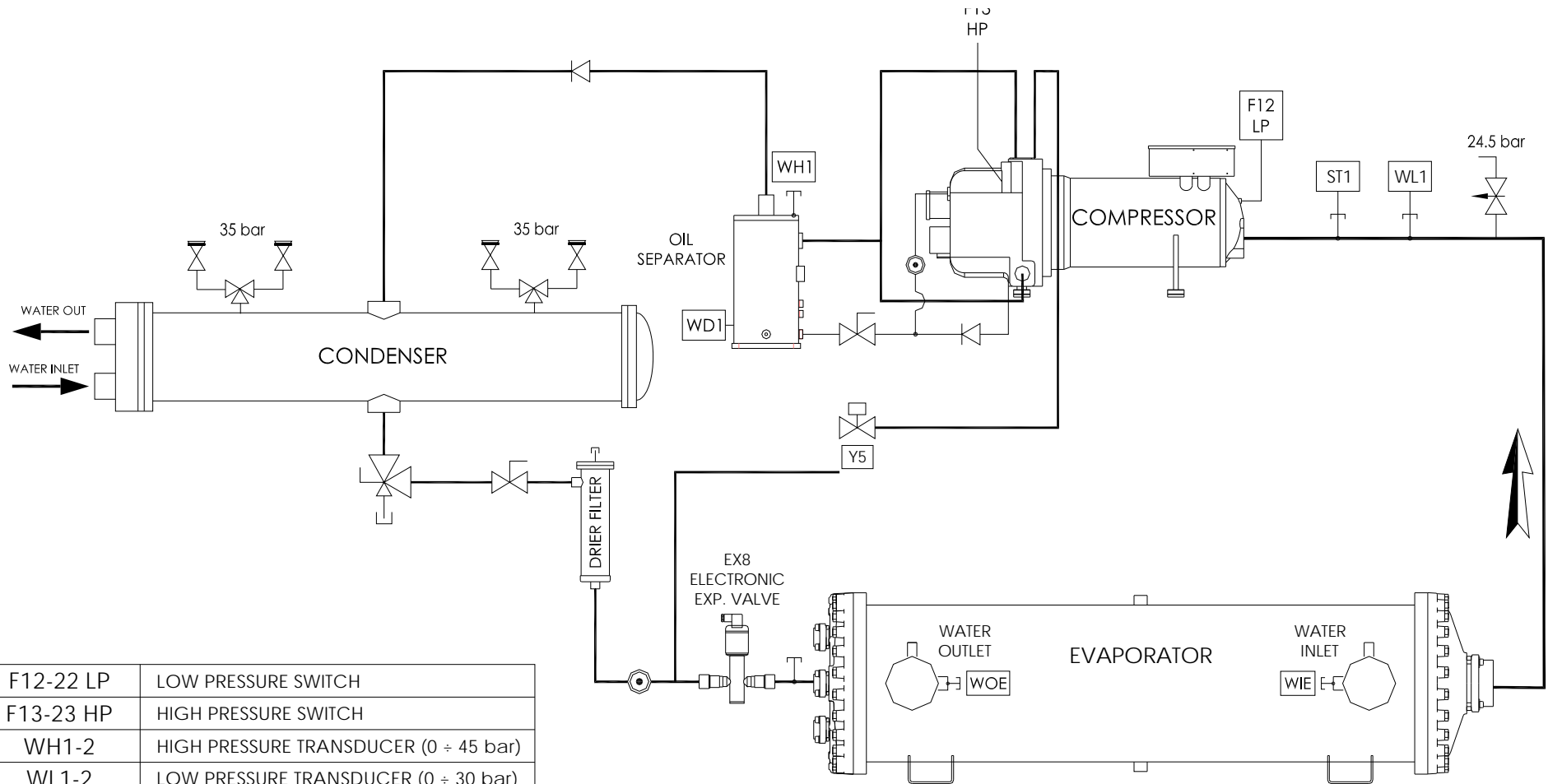
Once it has reached the superheated-vapour state, the refrigerant leaves the evaporator and is once again taken into the compressor to repeat the cycle.

**Fig. 19 - Refrigeration cycle of the EWWQ – AJYNN / EWWQ – AJYNN/A DUAL Fr4 unit**



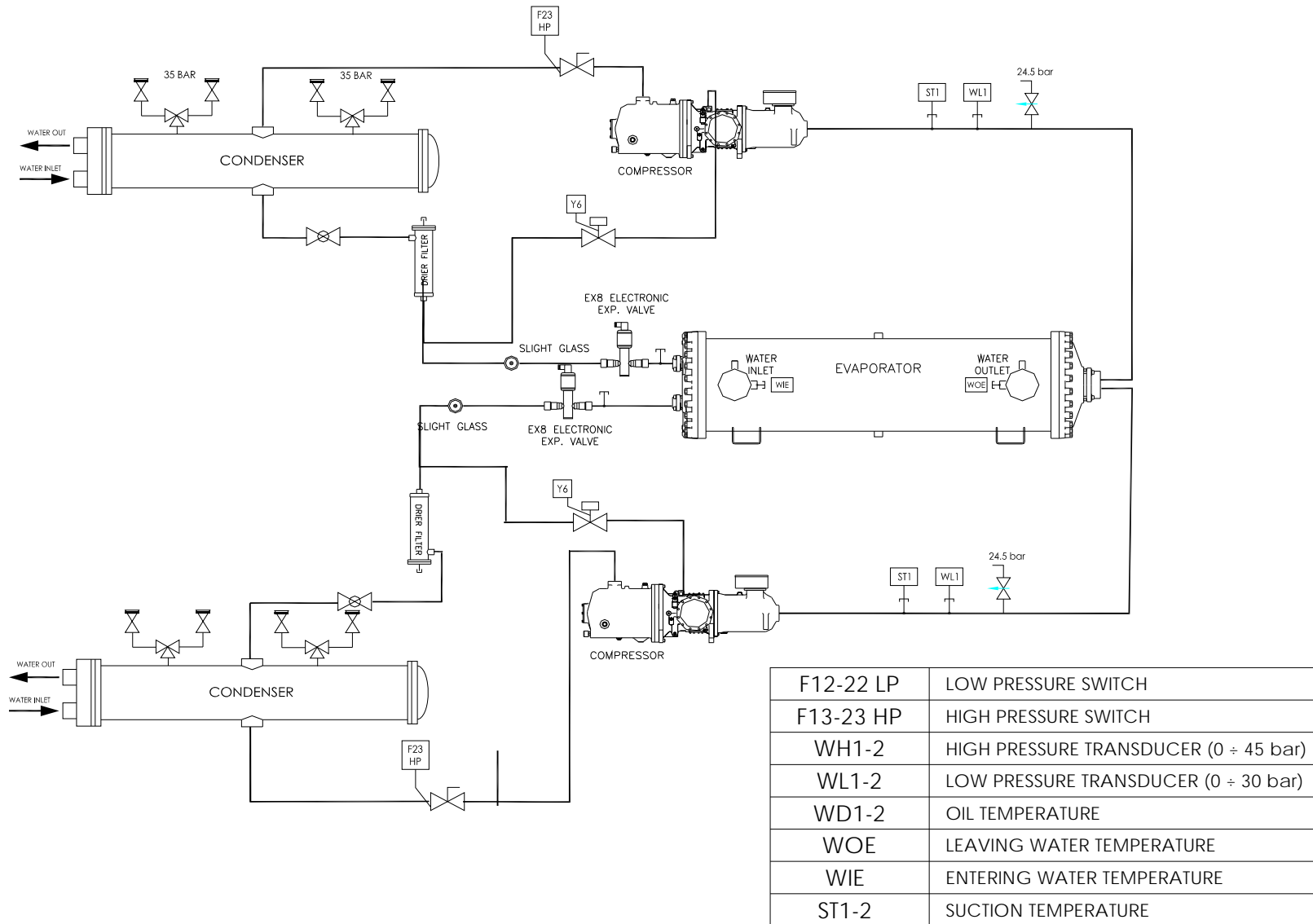
F12-22 LP	LOW PRESSURE SWITCH
F13-23 HP	HIGH PRESSURE SWITCH
WH1-2	HIGH PRESSURE TRANSDUCER (0 ÷ 45 bar)
WL1-2	LOW PRESSURE TRANSDUCER (0 ÷ 30 bar)
WD1-2	OIL TEMPERATURE
WOE	LEAVING WATER TEMPERATURE
WIE	ENTERING WATER TEMPERATURE
ST1-2	SUCTION TEMPERATURE

**Fig. 20 - Refrigeration cycle of the EWWQ – AJYNN / EWWQ – AJYNN/A Mono Fr4 unit**

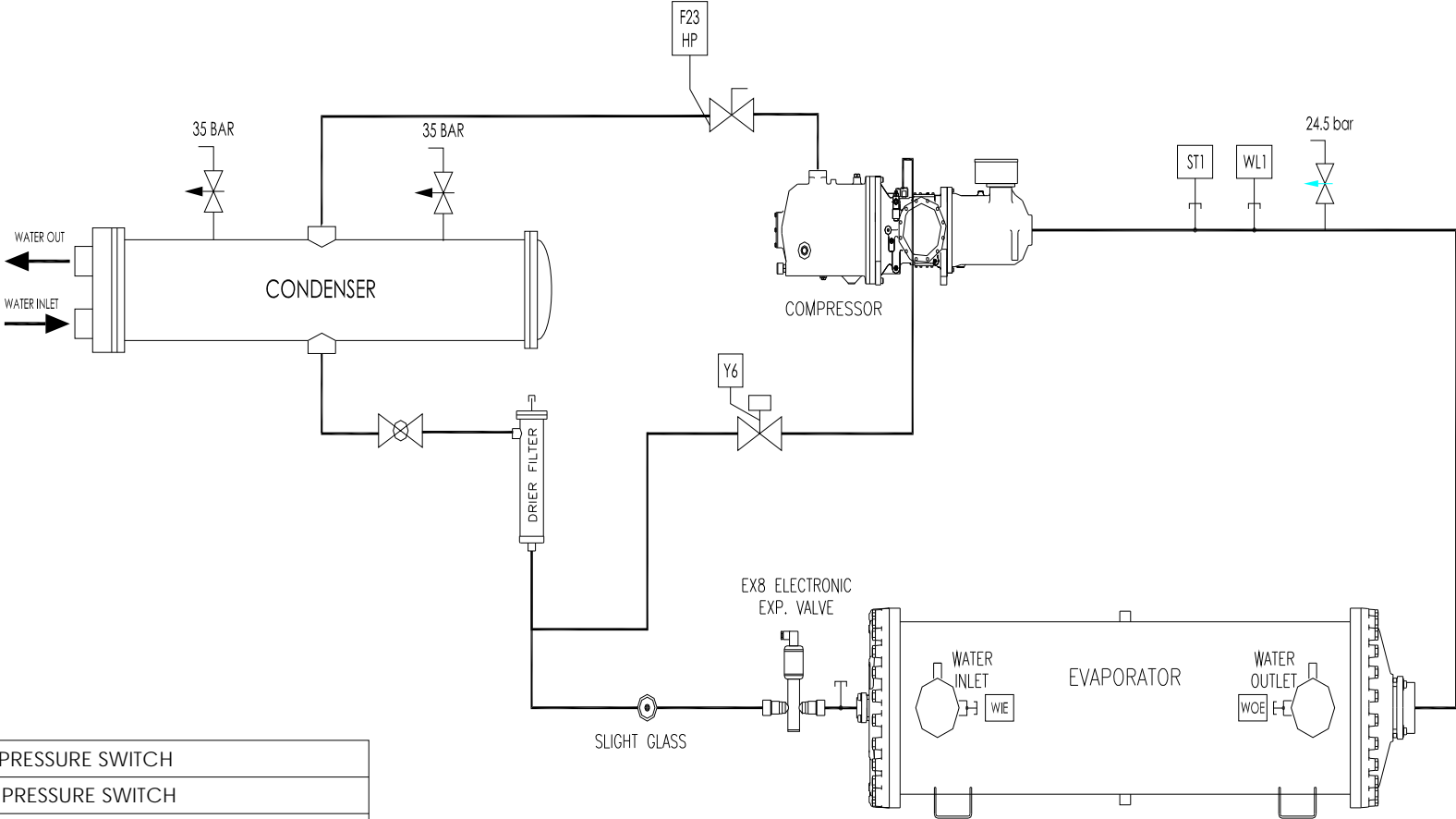


F12-22 LP	LOW PRESSURE SWITCH
F13-23 HP	HIGH PRESSURE SWITCH
WH1-2	HIGH PRESSURE TRANSDUCER (0 ÷ 45 bar)
WL1-2	LOW PRESSURE TRANSDUCER (0 ÷ 30 bar)
WD1-2	OIL TEMPERATURE
WOE	LEAVING WATER TEMPERATURE
WIE	ENTERING WATER TEMPERATURE
ST1-2	SUCTION TEMPERATURE

**Fig. 21 - Refrigeration cycle of the EWWQ – AJYNN / EWWQ – AJYNN/A DUAL 3200 unit**



**Fig. 22 - Refrigeration cycle of the EWWQ – AJYNN / EWWQ – AJYNN/A Mono 3200 unit**



F12-22 LP	LOW PRESSURE SWITCH
F13-23 HP	HIGH PRESSURE SWITCH
WH1-2	HIGH PRESSURE TRANSDUCER (0 ÷ 45 bar)
WL1-2	LOW PRESSURE TRANSDUCER (0 ÷ 30 bar)
WD1-2	OIL TEMPERATURE
WOE	LEAVING WATER TEMPERATURE
WIE	ENTERING WATER TEMPERATURE
ST1-2	SUCTION TEMPERATURE

## Description of the refrigeration cycle with partial heat recovery

The low-temperature refrigerant gas from the evaporator is drawn by the compressor through the electric motor, which is cooled by the refrigerant. It is subsequently compressed and during this process the refrigerant mixes with the oil from the oil separator.

The high-pressure oil-refrigerant mixture is introduced into the centrifuge-type high-efficiency oil separator, where the oil is separated from the refrigerant. The oil accumulated on the bottom of the separator is forced by the pressure difference back into the compressor while the oil-free refrigerant is sent to the condenser. The upper part of the condenser has cooling tubes through which about 10% of the heat rejection of the unit is recovered.

These condensers, with partial heat recovery tubes, have crowns with special couplings by which they can be connected to the hot water pipes. When partial recovery is activated, condenser performance is improved since the condenser temperature is lowered further in as much as the surface dedicated to heat discharge is greater.

After passing through the cooling tubes, the gas starts to condense in the central part of the condenser.

The condensed fluid at saturation temperature passes through the subcooling section where it loses even more heat, increasing the efficiency of the cycle. The subcooled fluid flows through the high-efficiency filter dryer and then reaches the expansion element (expansion valve) through which a fall in pressure starts off the expansion process resulting in the vaporisation of part of the refrigerant liquid.

The result at this point is a low-pressure and low-temperature liquid-gas mixture entering the evaporator, where it takes the heat required for vaporisation.

When the refrigerant liquid-vapour is uniformly distributed in the direct expansion evaporator tubes, heat is exchanged with the cooling water, thus reducing the temperature until complete evaporation, followed by superheating.

Once it has reached the superheated-vapour state, the refrigerant leaves the evaporator and is once again taken into the compressor to repeat the cycle.

## Controlling the partial recovery circuit and installation recommendations

The partial heat recovery system is not managed and/or controlled by the machine. The installer should follow the suggestions below for best system performance and reliability:

- 1) Install a mechanical filter on the heat exchanger inlet pipe.
- 2) Install shut-off valves to isolate the heat exchanger from the water system during periods of inactivity or system maintenance.
- 3) Install a drain valve that allows the heat exchanger to be emptied in the event that air temperature is expected to fall below 0°C during periods of inactivity of the machine.
- 4) Install flexible anti-vibration joints on the heat recovery water inlet and outlet piping, so that transmission of vibrations, and therefore of noise, to the water system is kept as low as possible.
- 5) Do not load exchanger joints with the weight of the heat recovery piping. The water joints of the exchangers are not designed to support the weight of the piping.
- 6) Should heat recovery water temperature be lower than ambient temperature, it is advised to switch off the heat recovery water pump 3 minutes after having switched off the last compressor.

## Compressor

The single-screw compressor is of the semi-hermetic type with an asynchronous three-phase, two-pole motor which is directly splined on the main shaft. The suction gas from the evaporator cools the electric motor before entering the suction ports. There are temperature sensors inside the electric motor which are completely covered by the coil winding and constantly monitor motor temperature. Should the coil winding temperature become very high (120°C), a special external device connected to the sensors and to the electronic controller will deactivate the corresponding compressor.

There are only two moving rotating parts and there are no other parts in the compressor with an eccentric and/or alternating movement.

The basic components are therefore only the main rotor and the satellites that carry out the compression process, meshing perfectly together.

Compression sealing is done thanks to a suitably shaped special composite material that is interposed between the main screw and the satellite. The main shaft on which the main rotor is splined is supported by 2 ball bearings. The system made up in this way is both statically and dynamically balanced before assembly.



**Fig. 23 - Picture of Fr4100 compressor**



**Fig. 24 – Picture of Fr3200 compressor**

In the Fr3200 and Fr4100 series compressor, access to internal parts is allowed by two covers positioned sidewise.

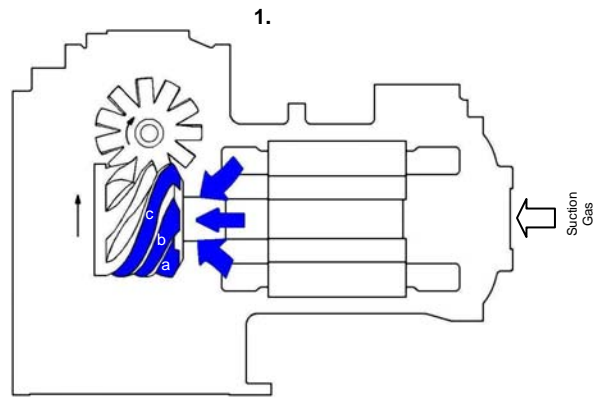
### **Compression process**

With the single-screw compressor the suction, compression and discharge process takes place in a continuous manner thanks to the upper satellite. In this process the suction gas penetrates into the profile between the rotor, the teeth of the upper satellite and the compressor body. The volume is gradually reduced by compression of the refrigerant. The compressed gas under high pressure is thus discharged into the built-in oil separator. In the oil separator, the gas/oil mixture and the oil are collected in a cavity in the lower part of the compressor, where they are injected into the compression mechanisms in order to guarantee compression's sealing and lubrication of the ball bearings.



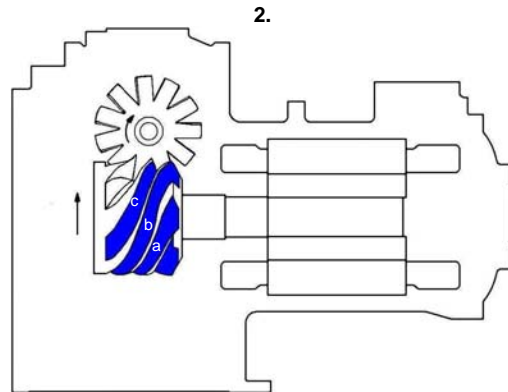
### 1. E 2. Suction

Main rotor flutes 'a', 'b' and 'c' are in communication at one end with the suction chamber and are sealed at the other end by the upper satellite teeth. As the main rotor turns, the effective length of the flutes increases, thus increasing the volume open to the suction chamber. Figure 1 clearly illustrates this process. As flute 'a' assumes the position of flutes 'b' and 'c' its volume increases, inducing suction vapour to enter the flute.



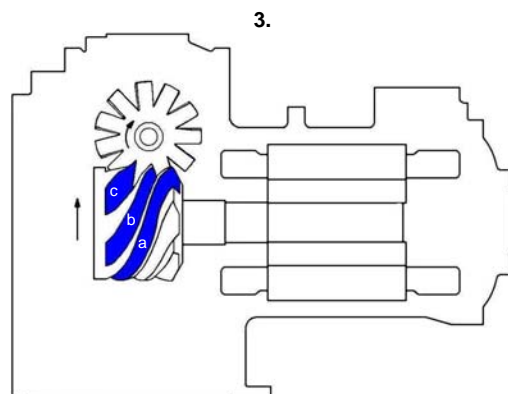
Upon further rotation of the main rotor, the flutes which have been open to the suction chamber engage with the satellite teeth. This coincides with each flute being progressively sealed by the main rotor.

Once the flute volume is closed off from the suction chamber, the suction stage of the compression cycle is complete.



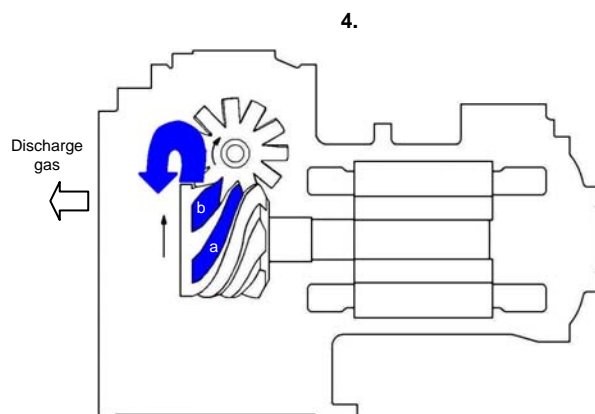
### 3. Compression

As the main rotor turns, the volume of gas trapped within the flute is reduced as the length of the flute shortens and compression occurs.



### 4. Discharge

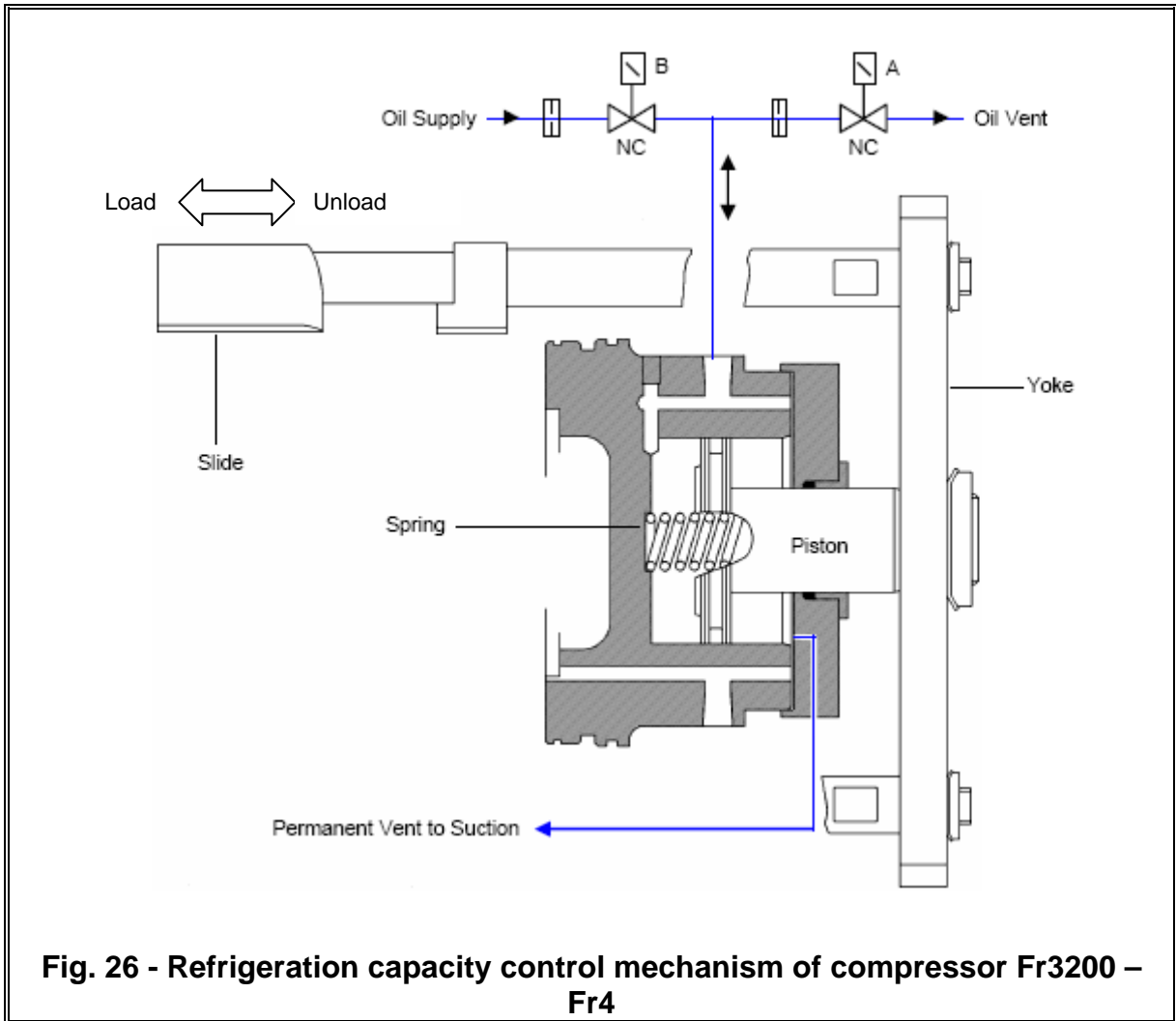
As the satellite tooth approaches the end of a flute, the pressure of the trapped vapour reaches a maximum value occurring when the leading edge of the flute begins to overlap the triangular shaped discharge port. Compression immediately ceases as the gas is delivered into the discharge manifold. The satellite tooth continues to scavenge the flute until the flute volume is reduced to zero. This compression process is repeated for each flute/satellite tooth in turn.

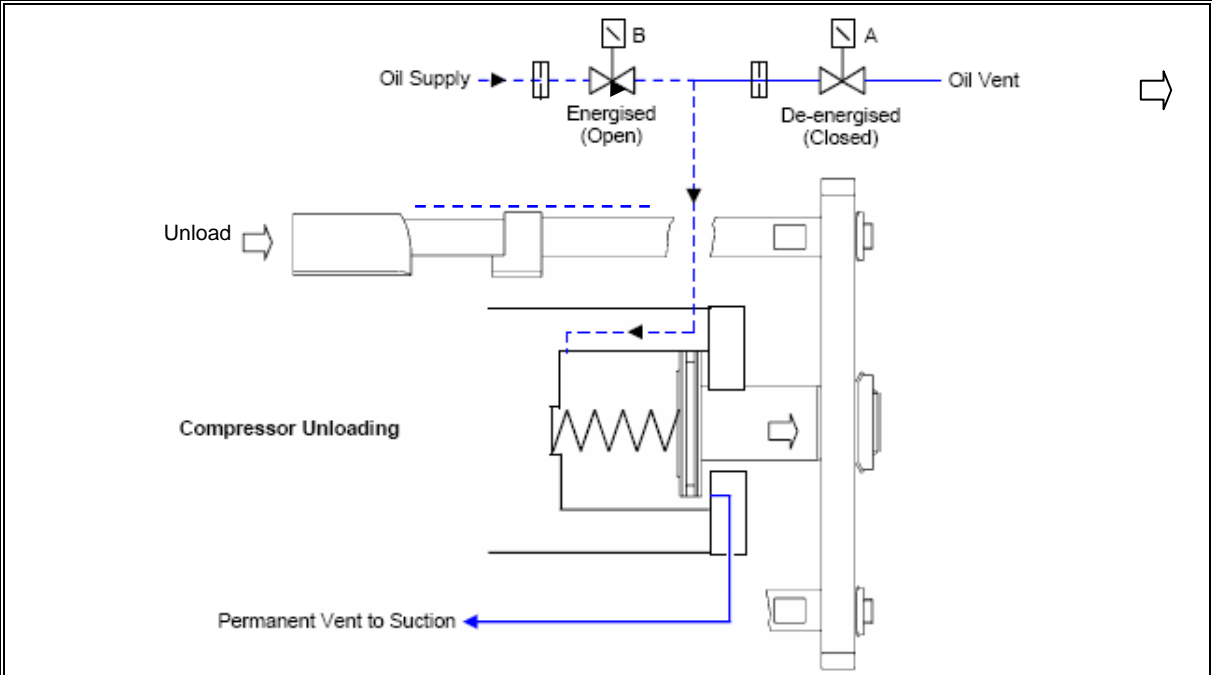


Oil separator not shown

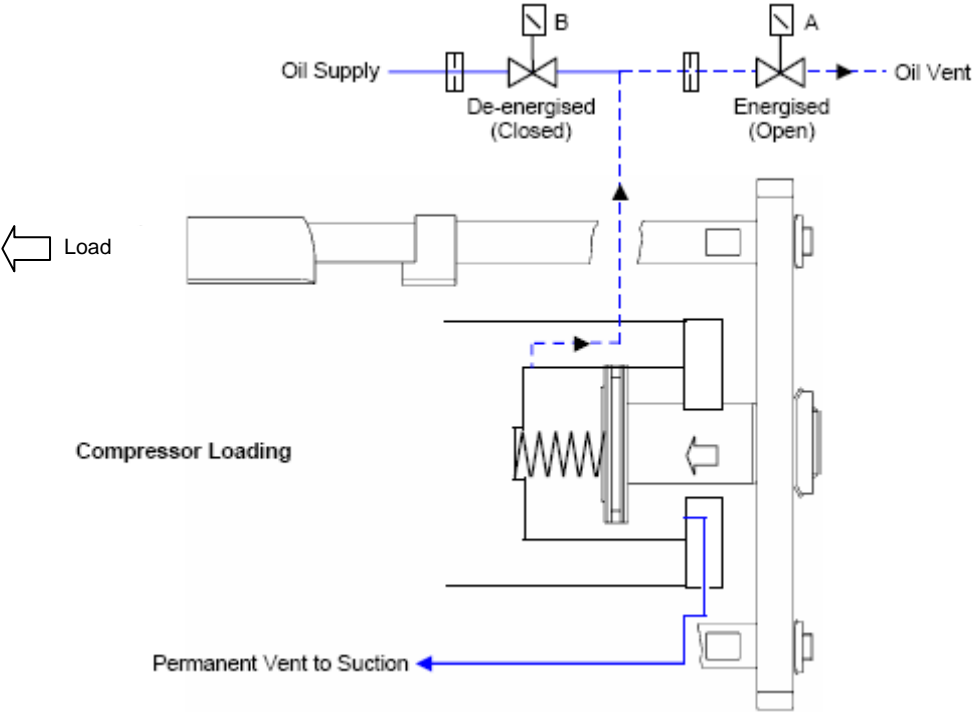
**Fig. 25 - Compression process**

FR3200 – FR4 Compressor





Spring Force + Oil Pressure > Suction/Discharge Differential Pressure = Slide valve moves toward unload



Suction/Discharge Differential Pressure > Spring Force = Slide valve moves toward load

CAPACITY CONTROL ACTION	SOLENOID VALVE A	<sup>1</sup> SOLENOID VALVE B
<b>Load compressor</b> Oil is vented from the capacity control cylinder. The suction/discharge differential pressure overcomes the force of the spring and moves the slide valve towards the maximum load position.	Energised (open)	De-energised (closed)
<b>Unload compressor</b> High-pressure oil is admitted to the capacity control cylinder. The force of the spring supplemented by oil pressure overcomes the suction/discharge differential pressure and moves the slide valve towards the minimum load position.	De-energised (closed)	Energised (open)
<b>Hold slide valve position</b> The slide valve is hydraulically locked at the desired load position.	De-energised (closed)	De-energised (closed)

**Fig. 27 - Capacity control mechanism**

# Pre-startup checks

## General

Once the machine has been installed, use the following procedure to check that it has been done correctly:

### ▲ CAUTION

Switch off the power supply of the machine before performing any checks.  
Failure to open the power switches at this stage can result in serious injury to the operator or even death.

Inspect all the electrical connections to the power circuits and to the compressors, including the contactors, fuse carriers and electrical terminals and check that they are clean and well secured. Even though these checks are carried out at the factory on every machine that is shipped, vibrations during transportation may loosen some electrical connections.

### ▲ CAUTION

Check that the electrical terminals of cables are well tightened. A loose cable can overheat and give rise to problems with the compressors.

Open discharge, liquid, liquid injection and suction (if installed) valves.

### ▲ ATTENTION

Do not start up the compressors if the delivery, liquid, liquid injection or suction valves are closed. Failure to open these valves can cause serious damage the compressor.  
It is absolutely forbidden to close the valves on the delivery and suction piping when the unit is running.  
These valves can be closed only when the compressor is off during maintenance of the unit. This operation must be carried out by qualified technical personnel holding the qualifications requested by local and/or European laws and with the adoption of the foreseen Personal and Collective Protection Devices.

Check the power supply voltage at the general door-block disconnecter switch terminals. The power supply voltage must be the same as that on the nameplate. Maximum allowed tolerance  $\pm 10\%$ .  
Voltage unbalance between the three phases must not exceed  $\pm 3\%$ .

The unit comes with a factory-supplied phase monitor that prevents compressors from starting if the phase sequence is incorrect. Properly connect the electrical terminals to the disconnecter switch so as to ensure alarm-free operation. If the phase monitor triggers an alarm once the machine has been powered, just invert two phases at the general disconnecting switch supply (unit power supply). Never invert the electrical wiring on the monitor.

### ▲ CAUTION

Starting up with the wrong sequence of phases irreparably compromises operation of the compressor. Ensure that phases L1, L2 and L3 correspond in sequence to R, S, and T.

Fill the water circuit and remove air from the system's highest point and open the air valve above the evaporator shell. Remember to close it again after filling. The design pressure on the water side of the evaporator is 10.0 bar. Never exceed this pressure at any time during the life of the machine.

### ▲ IMPORTANT

Before putting the machine into operation, clean the water circuit. Dirt, scaling, corrosion residue and other foreign material can accumulate inside the heat exchanger and reduce its heat exchanging capacity. Pressure drops can increase as well, thus reducing water flow. Proper water treatment therefore reduces the risk of corrosion, erosion, scaling, etc. The most appropriate water treatment must be determined locally, according to the type of system and local characteristics of the process water.  
The manufacturer is not responsible for damage to or malfunctioning of equipment caused by failure to treat water or by improperly treated water.

## Units with external water pump

Start the water pump and check the water system for any leaks; repair these if necessary. While the water pump is in operation, adjust the water flow until the design pressure drop for the evaporator is reached. Adjust the flow switch trigger point (not factory-supplied), to ensure operation of the machine within a  $\pm 20\%$  flow range.

### CAUTION

**From this moment onwards, the machine will be under electrical power. Use extreme caution during subsequent operation.**

**A lack of attention during subsequent operation may cause serious personal injury.**

## Electrical power supply

The machine's power supply voltage must be the same as that specified on the nameplate  $\pm 10\%$  while the voltage unbalance between phases must not be in excess of  $\pm 3\%$ . Measure the voltage between phases and if the value does not fall within the established limits, correct it before starting the machine.

### ATTENTION

Provide suitable power supply voltage. Unsuitable power supply voltage could cause malfunction of the control components and undesired triggering of the thermal protection devices, along with a considerable reduction in the life of the contactors and electric motors.

## Unbalance in power supply voltage

In a three-phase system, excessive unbalance between the phases causes overheating of the motor. The maximum allowed voltage unbalance is 3%, calculated as follows:

$$\text{Unbalance \%: } \frac{V_{\max} - V_{\text{average}}}{V_{\text{average}}} \times 100 = \text{ \_\_\_\_\_\_ \%}$$

Example: the three phases measure 383, 386 and 392 Volts respectively, the average is:

$$\frac{383+386+392}{3} = 387 \text{ Volts}$$

thus the unbalance percentage is:

$$\frac{392 - 387}{387} \times 100 = 1,29\% \quad \text{below the maximum allowed (3\%)}$$

## Electrical heaters power supply

Each compressor comes with an electrical heater located at the bottom of compressor. Its purpose is to warm up the lubricating oil and thus avoid the mixing of refrigerant fluid within.

It is therefore necessary to ensure that the heaters are powered at least 24 hours before the planned start-up time. To ensure that they are activated, it is sufficient to keep the machine on by closing the general disconnecting switch Q10.

The microprocessor, however, has a series of sensors that prevent the compressor from being started up when the oil temperature is not at least 5°C above the saturation temperature corresponding to the current pressure.

Keep the Q0, Q1, Q2 and Q12 switches in the Off (or 0) position until the machine is to be started up.

## Emergency Stop

The machine has an emergency stop system which cuts off power to the compressors, allowing the machine to stop safely in case of danger. The emergency stop is triggered off by pressing the red mushroom button on the door of the machine's electrical panel.

After the machine has stopped, an alarm signal is generated in the unit control card, which reports the triggering of the emergency stop and prevents the re-starting of the compressors. To restart the compressors:

- Reset the emergency button
- Cancel the alarm in the control card.

### CAUTION

The emergency button cuts off electrical power to the compressors, but not to the machine electrical panel. Take all necessary precautions therefore, if action must be taken on the machine subsequent to an emergency stop.

# Startup procedure

## Turning on the machine

1. With the general disconnecting switch Q10 closed, check that switches Q0, Q1, Q2 and Q12 are in the Off (or 0) position.
2. Close the thermal-magnetic switch Q12 and wait for the microprocessor and the control to start. Check that the oil temperature is warm enough. The oil temperature must be at least 5°C above the saturation temperature of the refrigerant in the compressor.  
If the oil is not warm enough, it will not be possible to start the compressors and the phrase "Oil Heating" will appear on the microprocessor display.
3. Start the water pump.
4. Turn the Q0 switch to On and wait for "Unit-On/Compressor Stand-By" to appear on the display.
5. Check that the evaporator pressure drop is the same as the design pressure drop and correct if necessary. The pressure drop must be measured at the factory-supplied charge connections placed on the evaporator piping. Do not measure the pressure drops at points where any valves and/or filters are interposed.
6. When starting up for the first time, turn the Q0 switch to Off to check that the water pump stays on for three minutes before it stops.
7. Turn the Q0 switch to On again.
8. Check that the local temperature setpoint is set to the required value by pressing the Set key.
9. Turn the Q1 switch to On (or 1) to start compressor #1.
10. Once the compressor has started, wait for at least 1 minute for the system to stabilise. During this time the controller will perform a series of operations to empty the evaporator (pre-purge) to ensure a safe start up.
11. At the end of the pre-purge, the microprocessor will start loading the compressor, now running, in order to reduce the outlet water temperature. Check the proper functioning of the capacity control by measuring the compressor's electrical current consumption.
12. Check refrigerant evaporation and condensation pressure.
13. Once the system has stabilized, check that the liquid sight glass located on the expansion valve inlet pipe is completely fully (without bubbles) and that the humidity indicator shows "Dry". Any bubbles inside the liquid sight glass might indicate a low refrigerant level or an excessive pressure drop through the filter dryer or an expansion valve that is blocked at the full open position.
14. In addition to checking the liquid sight glass, check circuit operating parameters by verifying:
  - a) Superheating of refrigerant at compressor suction
  - b) Superheating of refrigerant at compressor discharge
  - c) Subcooling of liquid coming out of the condenser banks
  - d) Evaporation pressure
  - e) Condensation pressure

Except for liquid temperature and suction temperature for machines with a thermostatic valve, which require the use of an external thermometer, all other measurements can be carried out by reading the relevant values directly on the on-board microprocessor display.

15. Turn the Q2 switch to On (or 1) to start compressor #2.
16. Repeat steps 10 through 15 for the second circuit.

**Table 13 - Typical operating conditions with compressors at 100%**

Economised cycle?	Suction superheating	Delivery superheating	Liquid subcooling
NO	4 ± 6 °C	20 ± 25 °C	5 ± 6 °C
YES	4 ± 6 °C	18 ± 23 °C	10 ± 15 °C

### ▲ IMPORTANT

The symptoms of a low refrigerant charge are: low evaporation pressure, high suction and exhaust superheating (beyond the above limits) and a low subcooling level. In this case, add R410A refrigerant to the relevant circuit. The system has been provided with a charge connection between the expansion valve and the evaporator. Charge refrigerant until working conditions return to normal.  
Remember to reposition the valve cover when finished.

17. To turn off the machine temporarily (daily or weekend shutdown) turn the Q0 switch to Off (or 0) or open the remote contact between terminals 58 and 59 on terminal board M3 (Installation of remote switch to be carried out by the customer). The microprocessor will activate the shutdown procedure, which requires several seconds. Three minutes after the compressors have been shut down, the microprocessor will shut down the pump. Do not switch off the main power supply so as not to de-activate the electrical resistances of the compressors and the evaporator.

## ▲ IMPORTANT

If the machine is not supplied with a built-in pump, do not shut down the external pump before 3 minutes have elapsed after the last compressor has shut down. Early shutdown of the pump triggers a water-flow failure alarm.

### Seasonal shutdown

1. Turn switches Q1 and Q2 to the Off (or 0) position to shut down the compressors, using the normal pump-down procedure.
2. After the compressors have been shut down, turn switch Q0 to the Off (or 0) position and wait for the built-in water pump to shut down. If the pump is managed externally, wait for 3 minutes after the compressors have shut down before turning off the pump.
3. Open the Q12 thermal-magnetic switch (Off position) inside the control section of the electrical board and then open the general disconnecting switch Q10 to cut off the machine's power supply entirely.
4. Close the compressor intake valves (if any) and delivery valves and also the valves located on the liquid and liquid injection line.
5. Place a warning sign on every switch that has been opened, advising to open all the valves before starting the compressors.
6. If no water and glycol mixture has been introduced into the system, discharge all the water from the evaporator and from the connected piping if the machine is to remain inactive during the winter season. One must remember that once the machine's power supply has been cut off, the anti-freeze electrical resistance cannot function. Do not leave the evaporator and piping exposed to the atmosphere during the entire period of inactivity.

### Starting up after seasonal shutdown

1. With the general disconnecting switch open, make sure that all the electrical connections, cables, terminals and screws are well tightened to ensure good electrical contact.
2. Verify that the power supply voltage applied to the machine is within  $\pm 10\%$  of the nominal nameplate voltage and that the voltage unbalance between the phases is no within  $\pm 3\%$  range.
3. Verify that all control devices are in good condition and functioning and that there is a suitable thermal load for start-up.
4. Verify that all the connection valves are well tightened and that there are no refrigerant leaks. Always reposition the valve covers.
5. Verify that switches Q0, Q1, Q2 and Q12 are in the open position (Off). Turn the general disconnecting switch Q10 to the On position. Doing this will allow to turn on the electrical resistances of the compressors. Wait at least 12 hours for them to warm up the oil.
6. Open all suction, delivery, liquid and liquid injection valves. Always reposition valve covers.
7. Open the water valves to fill the system and vent the air from the evaporator through the vent valve installed on its shell. Verify that there are no water leaks from the piping.

## System maintenance

### WARNING

All routine and non-routine maintenance activities on the machine must be carried out solely by qualified personnel who are familiar with the machine characteristics, operation and maintenance procedures, and who are aware of the safety requirements and risks involved.

### WARNING

It's absolutely forbidden to remove all the protections of the moving parts of the unit

### WARNING

The causes of repeated shutdowns deriving from triggering of safety devices must be investigated and corrected. Re-starting the unit after simply resetting the alarm can seriously damage the equipment.

### WARNING

A correct refrigerant and oil charge is essential for optimal operation of the machine and for environmental protection. Any oil and refrigerant recovery must conform to legislation in force.

## General

### IMPORTANT

Besides the checks suggested in the routine maintenance program, it is recommended to schedule periodical inspections, to be carried out by qualified personnel, as follows:

4 inspections per year (every three months) for units running about 365 days per year;

2 inspections per year (1 at seasonal start-up and the second one in the middle of the season) for units running about 180 days per year with seasonal operation.

1 inspection per year 1 (at seasonal start-up) for units running about 90 days per year with seasonal operation.

### IMPORTANT

The manufacturer of the unit requires users to have a complete check on the unit and on the state of the pressurised refrigeration circuits carried out after ten years of use, in compliance with Italian law (Lgs. Decree 93/2000), for all groups belonging to categories I and IV, containing fluids of group 2.

The manufacturer also recommends that all users analyse compressor vibrations annually and make routine inspections to check on possible refrigerant leaks. These checks ascertain that the refrigeration circuit is intact and safe and must be carried out according to local and/or European laws by personnel holding the qualifications required by such laws.

## Compressor maintenance

The analysis of vibrations is a good method for verifying the mechanical conditions of the compressor.

Verification of vibration readings immediately after start-up and periodically on an annual basis is recommended. The compressor load must be similar to the previous measurement's load to ensure measurement reliability.

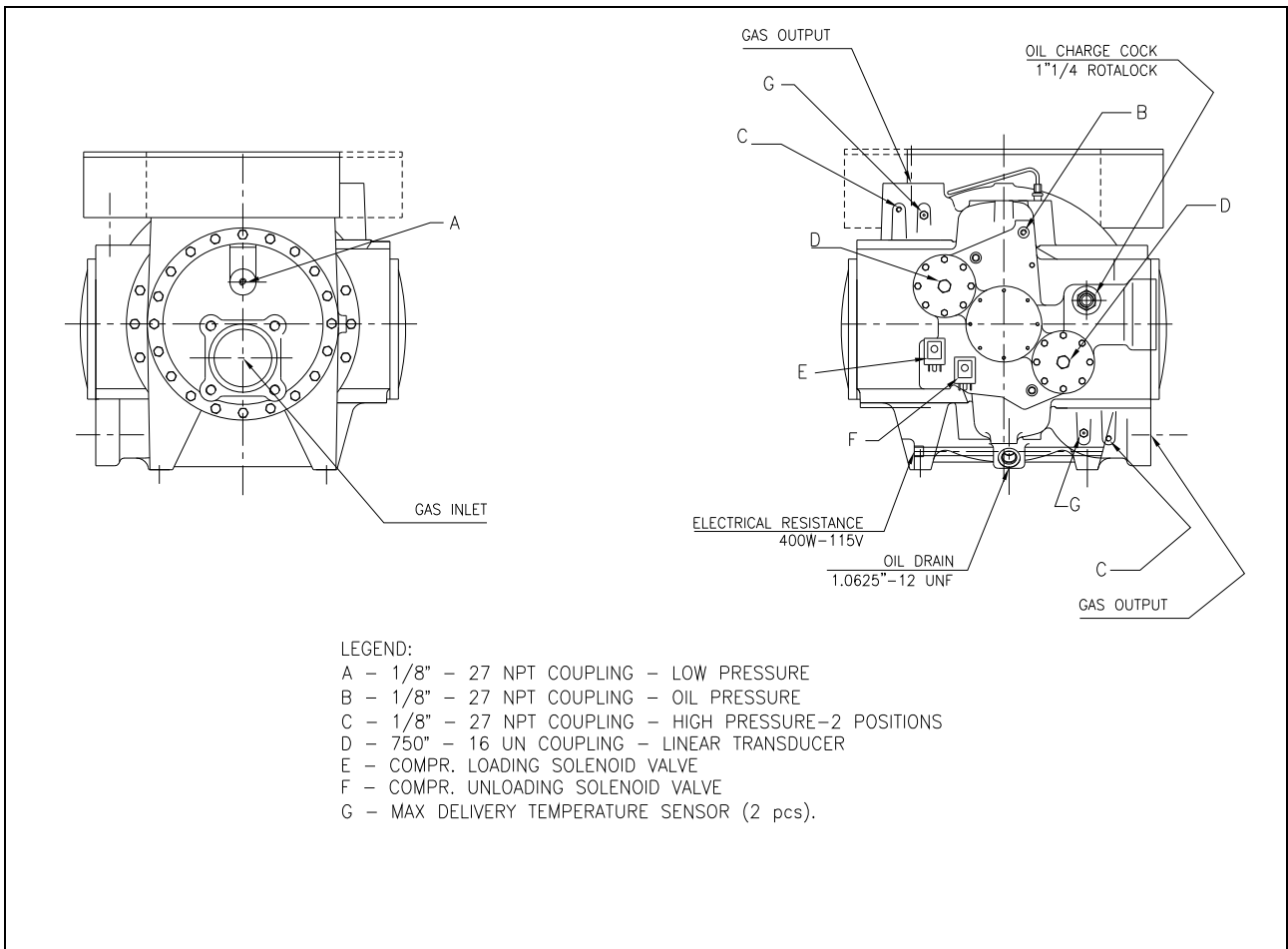
## Lubrication

The units do not require a routine procedure for lubrication of components.

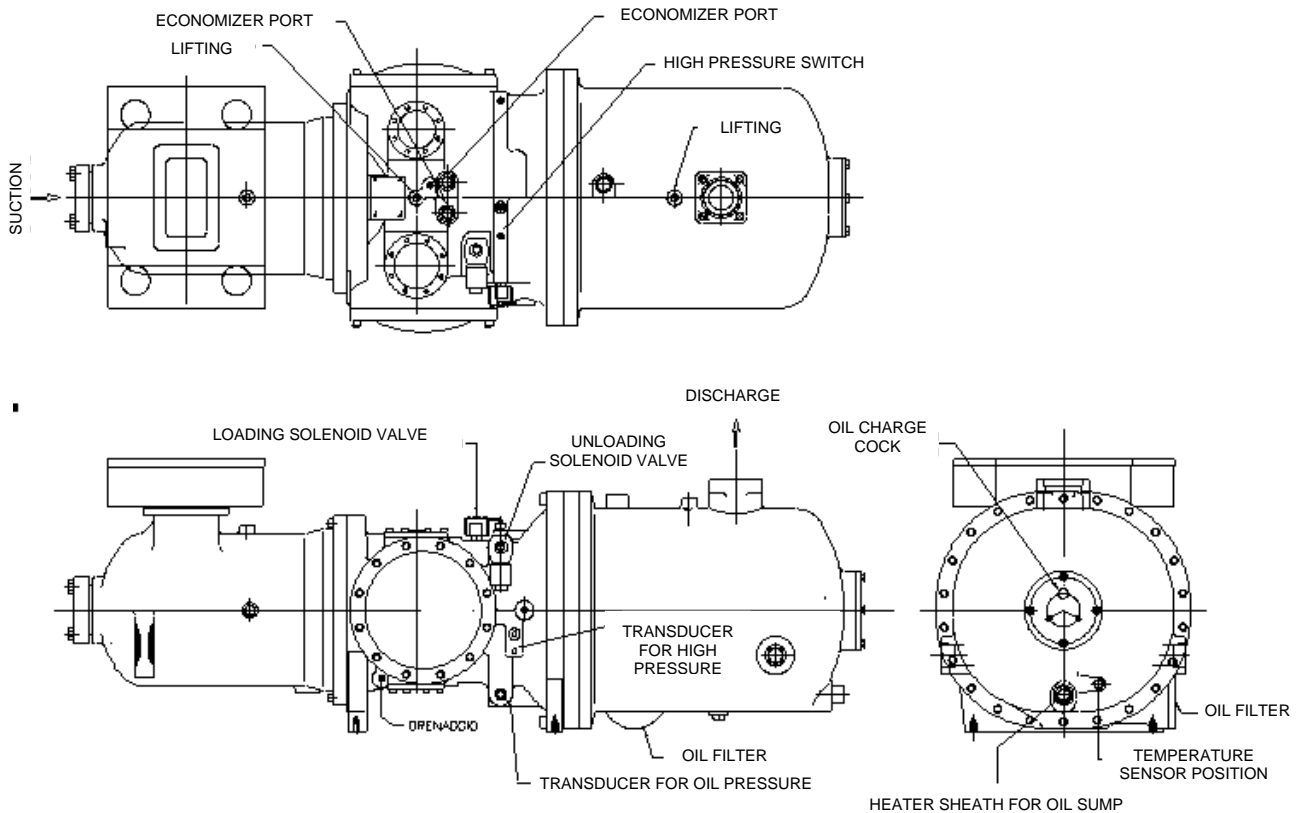
Compressor oil is of the synthetic type and is highly hygroscopic. It is therefore advised to limit its exposure to the atmosphere during storage and filling. It is recommended that the oil be exposed to the atmosphere for no more than 10 minutes.

The compressor oil filter is located under the oil separator (delivery side). Its replacement is advised when its pressure drop exceeds 2.0 bar. The pressure drop across the oil filter is the difference between the compressor discharge pressure and the oil pressure. Both these pressures can be monitored through the microprocessor for both compressors.





**Fig. 28 - Installation of control devices for Fr4 compressor**



**Fig. 29 - Installation of control devices for Fr3200 compressor**

## Routine maintenance

**Table 15 – Routine maintenance programme**

Activities	Weekly	Monthly (Note 1)	Yearly (Note 2)
<b>General:</b>			
Reading of operating data (Note 3)	X		
Visual inspection of machine for any damage and/or loosening		X	
Verification of thermal insulation integrity			X
Clean and paint where necessary			X
Analysis of water (Note 5)			X
<b>Electrical:</b>			
Verification of control sequence			X
Verify contactor wear – Replace if necessary			X
Verify that all electrical terminals are tight – Tighten if necessary			X
Clean inside the electrical control board			X
Visual inspection of components for any signs of overheating		X	
Verify operation of compressor and electrical resistance		X	
Measure compressor motor insulation using the Megger			X
<b>Refrigeration circuit:</b>			
Check for any refrigerant leakage		X	
Verify refrigerant flow using the liquid sight glass – Sight glass full	X		
Verify filter dryer pressure drop		X	
Verify oil filter pressure drop (Note 4)		X	
Analyse compressor vibrations			X
Analyse compressor oil acidity (Note 6)			X
Check safety valves (Note 7)		X	
<b>Condenser section:</b>			
Clean the exchangers (Note 8)			X

**Notes:**

- 1) Monthly activities include all the weekly ones
- 2) The annual (or early season) activities include all weekly and monthly activities
- 3) Machine operating values should be read on a daily basis thus keeping high observation standards
- 4) Replace the oil filter when the pressure drop across it reaches 2.0 bar
- 5) Check for any dissolved metals
- 6) TAN (Total Acid Number) :
  - ≤0.10 : No action
  - Between 0.10 and 0.19 : Replace anti-acid filters and re-check after 1000 running hours. Continue to replace filters until the TAN is lower than 0.10.
  - >0.19 : Change oil, replace oil filter and filter dryer. Verify at regular intervals.
- 7) **Safety valves**  
 Check that the lid and seal have not been tampered with.  
 Check that the discharge socket of the safety valves is not obstructed by any objects, rust or ice.  
 Check the manufacturing date shown on the safety valve. Replace the valve every 5 years and make sure it is compliant with the current regulations in terms of the installation of the unit.
- 8) Clean the pipes of the exchanger mechanically and chemically if the following occur: drop in the condenser water capacity, drop in the differential temperature between inlet and outlet water, high temperature condensation.

### Replacement of filter dryer

It is strongly advised that the filter dryer cartridges be replaced in the event of a considerable pressure drop across the filter or if bubbles are observed through the liquid sight glass while the subcooling value is within the accepted limits. Replacement of the cartridges is advised when the pressure drop across the filter reaches 50 kPa with the compressor under full load.

The cartridges must also be replaced when the humidity indicator in the liquid sight glass changes colour and shows excessive humidity, or when the periodic oil test reveals the presence of acidity (TAN is too high).

## Procedure to replace the filter dryer cartridge

### CAUTION

Ensure proper water flow through the evaporator during the entire servicing period. Interrupting the water flow during this procedure would cause the evaporator to freeze, with consequent breakage of internal piping.

1. Shut down the relevant compressor by turning the Q1 or Q2 switch to Off.
2. Wait until the compressor has stopped and close the valve located on the liquid line.
3. Once the compressor has stopped, place a label on the compressor start-up switch, to prevent undesired start-ups.
4. Close the compressor suction valve (if any).
5. Using a recovery unit, remove surplus refrigerant from the liquid filter until atmospheric pressure is reached. The refrigerant must be stored in a suitable and clean container.

### CAUTION

To protect the environment, do not release removed refrigerant into the atmosphere. Always use a recovery and storage device.

6. Balance internal pressure with external pressure by pressing the vacuum pump valve installed on the filter cover.
7. Remove the filter dryer cover.
8. Remove the filter elements.
9. Install the new filter elements in the filter.

### CAUTION

**Do not start the machine before the cartridge has been correctly inserted in the filter dryer. The unit manufacturer will accept no responsibility for any damage to persons or property caused during unit functioning if the filter dryer cartridges have not been correctly inserted.**

10. Replace the cover gasket. Do not allow any mineral oil onto the filter gasket so as not to contaminate the circuit. Use only compatible oil for this purpose (POE).
11. Close the filter cover.
12. Connect the vacuum pump to the filter and pull vacuum to 230 Pa.
13. Close the vacuum pump valve.
14. Recharge the filter with the refrigerant recovered during emptying.
15. Open the liquid line valve.
16. Open the suction valve (if any).
17. Start the compressor by turning switch Q1 or Q2.

## Replacement of filter dryer

It is strongly advised that the filter dryer cartridges be replaced in the event of a considerable pressure drop across the filter or if bubbles are observed through the liquid sight glass while the subcooling value is within the accepted limits. Replacement of the cartridges is advised when the pressure drop across the filter reaches 50 kPa with the compressor under full load.

The cartridges must also be replaced when the humidity indicator in the liquid sight glass changes colour and shows excessive humidity, or when the periodic oil test reveals the presence of acidity (TAN is too high).

## Procedure to replace the filter dryer cartridge

### ▲ ATTENTION

Ensure proper water flow through the evaporator during the entire servicing period. Interrupting the water flow during this procedure would cause the evaporator to freeze, with consequent breakage of internal piping.

18. Shut down the relevant compressor by turning the Q1 or Q2 switch to Off.
19. Wait until the compressor has stopped and close the valve located on the liquid line.

20. Once the compressor has stopped, place a label on the compressor start-up switch, to prevent undesired start-ups.
21. Close the compressor suction valve (if any).
22. Using a recovery unit, remove surplus refrigerant from the liquid filter until atmospheric pressure is reached. The refrigerant must be stored in a suitable and clean container.

### ▲ ATTENTION

To protect the environment, do not release removed refrigerant into the atmosphere. Always use a recovery and storage device.

23. Balance internal pressure with external pressure by pressing the vacuum pump valve installed on the filter cover.
24. Remove the filter dryer cover.
25. Remove the filter elements.
26. Install the new filter elements in the filter.

### ▲ ATTENTION

**Do not start the machine before the cartridge has been correctly inserted in the filter dryer. The unit manufacturer will accept no responsibility for any damage to persons or property caused during unit functioning if the filter dryer cartridges have not been correctly inserted.**

27. Replace the cover gasket. Do not allow any mineral oil onto the filter gasket so as not to contaminate the circuit. Use only compatible oil for this purpose (POE).
28. Close the filter cover.
29. Connect the vacuum pump to the filter and pull vacuum to 230 Pa.
30. Close the vacuum pump valve.
31. Recharge the filter with the refrigerant recovered during emptying.
32. Open the liquid line valve.
33. Open the suction valve (if any).
34. Start the compressor by turning switch Q1 or Q2.

## Replacement of the oil filter

### ▲ ATTENTION

The lubrication system has been designed to keep most of the oil charge inside the compressor. During operation, however, a small amount of oil circulates freely in the system, conveyed by the refrigerant. The amount of replacement oil going into the compressor should therefore be equal to the quantity removed rather than the amount stated on the nameplate; this will avoid excess of oil during the following start-up.

The quantity of oil removed from the compressor must be measured after having allowed the refrigerant present in the oil to evaporate for a suitable amount of time. To reduce the refrigerant content in the oil to a minimum, it is advised that the electrical resistances be kept on and that the oil be removed only when it has reached a temperature of 35÷45°C.

### ▲ ATTENTION

The replacement of the oil filter requires careful attention with regard to oil recovering; the oil must not be exposed to air for more than about 30 minutes.

In case of doubts, verify oil acidity or, if it is not possible to carry out the measurement, replace the charge of lubricant with fresh oil stored in sealed tanks or in a way that meet supplier specifications.

## Fr3200 compressor

The compressor oil filter is located under the oil separator (discharge side). It is strongly advised that it be replaced when its pressure drop exceeds 2.0 bar. The pressure drop across the oil filter is the difference between the compressor delivery pressure minus oil pressure. Both pressures can be controlled through the microprocessor for both compressors.

Required materials:

Oil filter Code 95816-401	– Quantity 1
Gaskets kit Code 128810988	– Quantity 1

Compatible oils:

Mobile Eal Arctic 68  
ICI Emkarate RL 68H

The standard oil charge for a compressor is 16 litres.

#### Procedure to replace oil filter

- 1) Shut down both compressors by turning the Q1 and Q2 switches to the Off position.
- 2) Turn the Q0 switch to Off, wait for the circulation pump to turn off and open the general disconnecting switch Q10 to cut off the machine's electrical power supply.
- 3) Place a label on the handle of the general disconnecting switch in order to prevent accidental start-up.
- 4) Close the suction, discharge and liquid injection valves.
- 5) Connect the recovery unit to the compressor and recover the refrigerant in a suitable and clean container.
- 6) Evacuate the refrigerant until the internal pressure has turned negative (compared to atmospheric pressure). The amount of refrigerant dissolved in the oil is reduced to a minimum in this way.
- 7) Drain the oil in the compressor by opening the drain valve located under the oil separator.
- 8) Remove the oil filter cover and remove the internal filter element.
- 9) Replace the cover and internal sleeve gaskets. Do not lubricate the gaskets with mineral oil in order not to contaminate the system.
- 10) Insert the new filter element.
- 11) Reposition the filter cover and tighten the screws. The screws must be tightened alternately and progressively setting the torque wrench at 60 Nm.
- 12) Charge the oil from the upper valve located on the oil separator. Considering the high hygroscopy of ester oil, it should be charged as quickly as possible. Do not expose ester oil to the atmosphere for more than 10 minutes.
- 13) Close the oil charging valve.
- 14) Connect the vacuum pump and evacuate the compressor up to a vacuum of 230 Pa.
- 15) On reaching the above vacuum level, close the vacuum pump valve.
- 16) Open the system's delivery, suction and liquid injection valves.
- 17) Disconnect the vacuum pump from the compressor.
- 18) Remove the warning label from to the general disconnecting switch.
- 19) Close the general disconnecting switch Q10 to supply power to the machine.
- 20) Start the machine by following the start-up procedure described above.

#### FR4 compressor

### ▲ ATTENTION

The lubrication system has been designed to keep most of the oil charge inside the compressor. During operation, however, a small amount of oil circulates freely in the system, conveyed by the refrigerant. The amount of replacement oil going into the compressor should therefore be equal to the quantity removed rather than the amount stated on the nameplate; this will avoid excess of oil during the following start-up.

The quantity of oil removed from the compressor must be measured after having allowed the refrigerant present in the oil to evaporate for a suitable amount of time. To reduce the refrigerant content in the oil to a minimum, it is advised that the electrical resistances be kept on and that the oil be removed only when it has reached a temperature of 35÷45°C.

### ▲ ATTENTION

The replacement of the oil filter requires careful attention with regard to oil recovering; the oil must not be exposed to air for more than about 30 minutes.

In case of doubts, verify oil acidity or, if it is not possible to carry out the measurement, replace the charge of lubricant with fresh oil stored in sealed tanks or in a way that meet supplier specifications.

#### Fr4200 compressor

The compressor oil filter is located at the coupling of the oil inlet piping and the compressor body (suction side). It is strongly advised that it be replaced when its pressure drop exceeds 2.0 bar. The pressure drop across the oil filter is the difference between the compressor delivery pressure minus oil pressure. Both pressures can be controlled through the microprocessor for both compressors.

Required materials:

Oil filter Code 95816-401 – Quantity 1  
Gaskets kit Code 128810988 – Quantity 1

Compatible oils:

Mobil Eal Arctic 68

## ICI Emkarate RL 68H

The standard oil charge for a compressor is 16 litres.

### Oil filter replacement procedure

#### Procedure to replace oil filter

- 1) Shut down both compressors by turning the Q1 and Q2 switches to the Off position.
- 2) Turn the Q0 switch to Off, wait for the circulation pump to turn off and open the general disconnecting switch Q10 to cut off the machine's electrical power supply.
- 3) Place a label on the handle of the general disconnecting switch in order to prevent accidental start-up.
- 4) Close the suction, discharge and liquid injection valves.
- 5) Connect the recovery unit to the compressor and recover the refrigerant in a suitable and clean container.
- 6) Evacuate the refrigerant until the internal pressure has turned negative (compared to atmospheric pressure). The amount of refrigerant dissolved in the oil is reduced to a minimum in this way.
- 7) Drain the oil in the compressor by opening the drain valve located under the oil separator.
- 8) Remove the oil filter cover and remove the internal filter element.
- 9) Replace the cover and internal sleeve gaskets. Do not lubricate the gaskets with mineral oil in order not to contaminate the system.
- 10) Insert the new filter element.
- 11) Reposition the filter cover and tighten the screws. The screws must be tightened alternately and progressively setting the torque wrench at 60 Nm.
- 12) Charge the oil from the upper valve located on the oil separator. Considering the high hygroscopy of ester oil, it should be charged as quickly as possible. Do not expose ester oil to the atmosphere for more than 10 minutes.
- 13) Close the oil charging valve.
- 14) Connect the vacuum pump and evacuate the compressor up to a vacuum of 230 Pa.
- 15) On reaching the above vacuum level, close the vacuum pump valve.
- 16) Open the system's delivery, suction and liquid injection valves.
- 17) Disconnect the vacuum pump from the compressor.
- 18) Remove the warning label from to the general disconnecting switch.
- 19) Close the general disconnecting switch Q10 to supply power to the machine.
- 20) Start the machine by following the start-up procedure described above.

### Refrigerant charge

#### ▲ ATTENTION

The units have been designed to operate with R410A refrigerant. So DO NOT USE refrigerants other than R410A.

#### ▲ ATTENTION

When refrigerant gas is added to or removed from the system, ensure proper water flow through the evaporator for the entire charge/discharge time. Interrupting the water flow during this procedure would cause the evaporator to freeze with consequent breakage of its internal piping.  
Damage caused by freezing makes the warranty void.

#### ▲ WARNING

Removal of the refrigerant and replenishing operations must be performed by technicians who are qualified to use the appropriate materials for this unit. Unsuitable maintenance can result in uncontrolled losses in pressure and fluid. Do not disperse the refrigerant and lubricating oil in the environment. Always be equipped with a suitable recovery system.

The units ship with a full refrigerant charge, but in some cases it might be necessary to replenish the machine in the field.

#### ▲ WARNING

Always verify the causes of a loss of refrigerant. Repair the system if necessary then recharge it.

The machine can be replenished under any stable load condition (preferably between 70 and 100%) and under any ambient temperature condition (preferably above 20°C). The machine should be kept running for at least 5 minutes to allow the condensation pressure to stabilise.

The subcooling value is about 3-4°C.

Once the subcooling section has been completely filled, additional refrigerant will not increase system efficiency. However, a small additional quantity of refrigerant (1÷2 kg) makes the system slightly less sensitive.

**N.B.:** Subcooling varies and requires a few minutes to re-stabilise. However, subcooling should not come below 2°C under any condition. Also, the subcooling value can change slightly as the water temperature and the suction superheating vary. As the suction superheating value decreases, there is a corresponding decrease in subcooling.

One of the two following scenarios can arise in a machine without refrigerant:

1. If the refrigerant level is slightly low, flow of bubbles can be seen through the liquid sight glass. Replenish the circuit as described in the replenishment procedure.
2. If the gas level in the machine is moderately low, the corresponding circuit could have some low-pressure stops. Replenish the corresponding circuit as described in the replenishment procedure.

### **Procedure to replenish refrigerant**

- 1) If the machine has lost refrigerant, it is necessary to first establish the causes before carrying out any replenishment operation. The leak must be found and repaired. Oil stains are a good indicator, as they can appear in the vicinity of a leak. However, this is not necessarily always a good search criterion. Searching with soap and water can be a good method for medium to large leaks, while an electronic leak detector is required to find small leaks.
- 2) Add refrigerant to the system through the service valve on the suction pipe or through the Schrader valve located on the evaporator inlet pipe.
- 3) The refrigerant can be added under any load condition between 25 and 100% of the system capacity. Suction superheating must be between 4 and 6°C.
- 4) Add enough refrigerant to fill the liquid sight glass entirely, so that no flow of bubbles can be seen anymore. Add an extra 2 ÷ 3 kg of refrigerant as a reserve, to fill the subcooler if the compressor is operating at 50 – 100% load.
- 5) Check the subcooling value by reading the liquid pressure and the liquid temperature near the expansion valve. The subcooling value must be between 3 and 5°C. The subcooling value will be lower at 75 ÷ 100% load and higher at 50% load.
- 6) Overcharging the system will cause a rise in the compressor's discharge pressure.

# Standard Checks

---

## Temperature and pressure sensors

The unit comes factory-equipped with all the sensors listed below. Periodically check that their measurements are correct by means of reference instruments (manometers, thermometers); correct the wrong readings as necessary using the microprocessor keypad. Well-calibrated sensors ensure better efficiency for the machine and a longer lifetime.

Note: Refer to the microprocessor use and maintenance manual for a complete description of applications, settings and adjustments.

All sensors are preassembled and connected to the microprocessor. The descriptions of each sensor are listed below:

**Outlet water temperature sensor** – This sensor is located on the evaporator outlet water connection and is used by the microprocessor to control the machine load depending on the system's thermal load. It also helps control the evaporator's antifreeze protection.

**Inlet water temperature sensor** – This sensor is located on the evaporator inlet water connection and is used for monitoring the return water temperature.

**Compressor discharge pressure transducer** – This is installed on every compressor and allows to monitor the discharge pressure and to control the fans. Should the condensation pressure increase, the microprocessor will control the compressor load in order to allow it to function even if the compressor flow gas must be reduced. It also contributes to the oil control logic.

**Oil pressure transducer** – This is installed on every compressor and allows to monitor the oil pressure. The microprocessor uses this sensor to inform the operator on the conditions of the oil filter and on how the lubrication system is functioning. By working together with the high- and low-pressure transducers, it protects the compressor from problems deriving from poor lubrication.

**Low-pressure transducer** – This is installed on every compressor and allows to monitor the compressor suction pressure along with low pressure alarms. It contributes to complementing the oil control logic.

**Suction sensor** – This is installed optionally (if the electronic expansion valve has been requested) on every compressor, and allows to monitor the suction temperature. The microprocessor uses the signal from this sensor to control the electronic expansion valve.

**Compressor discharge temperature sensor** – This is installed on every compressor and allows to monitor compressor discharge pressure and oil temperature. The microprocessor uses the signal from this sensor to control the liquid injection and to shut down the compressor in case that the discharge temperature reaches 110°C. It also protects the compressor from pumping liquid refrigerant at start-up.



# Test sheet

It is recommended that the following operation data are recorded periodically in order to verify correct operation of the machine over time. These data will also be extremely useful to the technicians who will be performing routine and/or non-routine maintenance on the machine.

## Water side measurements

Chilled water setpoint	°C	_____
Evaporator outlet water temperature	°C	_____
Evaporator inlet water temperature	°C	_____
Evaporator pressure drop	kPa	_____
Evaporator water flow rate	m <sup>3</sup> /h	_____

## Refrigerant side measurements

### Circuit #1:

	Compressor load	_____	%
	N. of expansion valve cycles (electronic only)	_____	
Refrigerant/Oil pressure	Evaporation pressure	_____	
	Condensation pressure	_____	bar
Refrigerant temperature	Oil pressure	_____	bar
	Evaporation saturated temperature	_____	bar
	Suction gas temperature	_____	°C
	Suction superheating	_____	°C
	Condensation saturated temperature	_____	°C
	Discharge superheating	_____	°C
	Liquid temperature	_____	°C
	Subcooling	_____	°C

### Circuit #2

	Compressor load	_____	%
	N. of expansion valve cycles (electronic only)	_____	
Refrigerant/Oil pressure	Evaporation pressure	_____	
	Condensation pressure	_____	bar
Refrigerant temperature	Oil pressure	_____	bar
	Evaporation saturated temperature	_____	bar
	Suction gas temperature	_____	°C
	Suction superheating	_____	°C
	Condensation saturated temperature	_____	°C
	Discharge superheating	_____	°C
	Liquid temperature	_____	°C
	Subcooling	_____	°C
External air temperature		_____	°C

## Electrical measurements

### Analysis of the unit's voltage unbalance:

Phases:	<b>RS</b>	<b>ST</b>	<b>RT</b>
	_____ V	_____ V	_____ V

$$\text{Unbalance \%} = \frac{V_{\max} - V_{\text{average}}}{V_{\text{average}}} \times 100 = \text{_____ \%}$$

### Compressors current – Phases:

	<b>R</b>	<b>S</b>	<b>T</b>
Compressor #1	_____ A	_____ A	_____ A
Compressor #2	_____ A	_____ A	_____ A

### Fans current:

#1	_____ A	#2	_____ A
#3	_____ A	#4	_____ A
#5	_____ A	#6	_____ A
#7	_____ A	#8	_____ A

## **Service and limited warranty**

---

All machines are factory-tested and guaranteed for 12 months as of the first start-up or 18 months as of delivery. These machines have been developed and constructed according to high quality standards ensuring years of failure-free operation. It is important, however, to ensure proper and periodical maintenance in accordance with all the procedures listed in this manual.

We strongly advise stipulating a maintenance contract with a service authorized by the manufacturer in order to ensure efficient and problem-free service, thanks to the expertise and experience of our personnel.

It must also be taken into consideration that the unit requires maintenance also during the warranty period.

It must be borne in mind that operating the machine in an inappropriate manner, beyond its operating limits or not performing proper maintenance according to this manual can void the warranty.

Observe the following points in particular, in order to conform to warranty limits:

1. The machine cannot function beyond the specified limits
2. The electrical power supply must be within the voltage limits and without voltage harmonics or sudden changes.
3. The three-phase power supply must not have an unbalance between phases exceeding 3%. The machine must stay turned off until the electrical problem has been solved.
4. No safety device, either mechanical, electrical or electronic must be disabled or overridden.
5. The water used for filling the water circuit must be clean and suitably treated. A mechanical filter must be installed at the point closest to the evaporator inlet.
6. Unless there is a specific agreement at the time of ordering, the evaporator water flow rate must never be above 120% and below 80% of the nominal flow rate.

## **Obligatory routine checks and starting up apparatuses under pressure**

---

The units are included in category IV of the classification according to European Directive PED 97/23/EC.

For chillers belonging to this category, some local regulations require a periodic inspection by an authorized agency. Please check with your local requirements.

## **Important information regarding the refrigerant used**

---

This product contains fluorinated greenhouse gases covered by the Kyoto Protocol. Do not vent gases into the atmosphere.

Refrigerant type: R410A  
GWP(1) value: 1975

(1)GWP = global warming potential

The refrigerant quantity is indicated on the unit name plate.  
Periodical inspections for refrigerant leaks may be required depending on European or local legislation.  
Please contact your local dealer for more information.

## **Disposal**

The unit is made of metal and plastic parts. All these parts must be disposed of in accordance with the local regulations in terms of disposal. Lead batteries must be collected and taken to specific refuse collection centres.



We reserve the right to make changes in design and construction at any time without notice, thus the cover picture is not binding.

## Water cooled screw chillers

EWQ 400-C20 AJYNN  
EWQ 440-C22 AJYNN/A



Daikin units comply with the European regulations that guarantee the safety of the product.



Daikin Europe N.V. is participating in the EUROVENT Certification Programme. Products are as listed in the EUROVENT Directory of Certified Products.

*DAIKIN EUROPE N.V.*

Zandvoordestraat 300  
B-8400 Ostend – Belgium  
[www.daikineurope.com](http://www.daikineurope.com)