



## Domestic Air conditioner

# ***TECHNICAL DATA***

## **ON/OFF**

### Wall mounted Type R-Series

HSU-09H03/R(QXF)  
HSU-12H03/R(QXF)

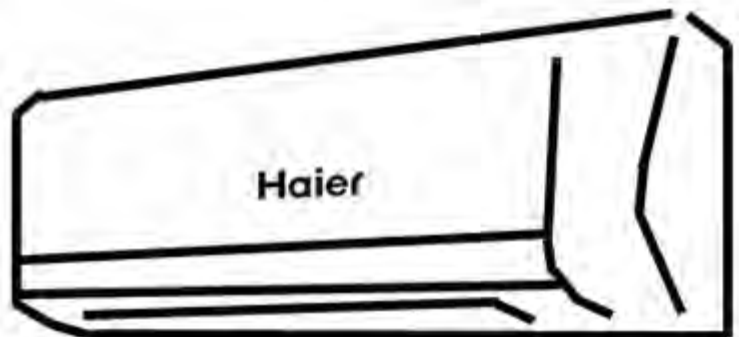

## **CAUTION**

1. READ THIS MANUAL CAREFULLY TO  
DIAGNOSE TROUBLE CORRECTLY  
BEFORE OFFERING SERVICE.
2. THIS MANUAL IS USED BY QUALIFIED  
APPLIANCE TECHNICIANS ONLY.
3. HAIER DOES NOT ASSUME ANY  
RESPONSIBILITY FOR PROPERTY  
DAMAGE OR PERSONAL INJURY FOR  
IMPROPER  
SERVICE PROCEDURES DONE BY ONE  
UNQUALIFIED PERSON.

# Table of Contents

<b>1. Features</b> .....	2
<b>2. Specifications</b> .....	3
<b>3. Remote controller lists</b> .....	6
<b>4. Sensors lists</b> .....	6
<b>5. Dimensional drawings</b> .....	7
<b>6. Operation range</b> .....	9
<b>7. Piping diagrams</b> .....	10
<b>8. Wiring diagrams</b> .....	11
<b>9. Capacity diagrams and curves diagrams</b> .....	12
<b>10. Sound level</b> .....	16
<b>11. Accessories</b> .....	18
<b>12. Control systems</b> .....	19
<b>13. Center of gravity</b> .....	20
<b>14. Installations</b> .....	21

# 1 Features



Healthy negative ion: make your room full of an abundance natural negative ions



Left&right flow: With specialized motor and flaps,the airflow can be adjusted



DRY function: Make dehumidifying in the room when the unit is working in the "DRY" mode



Child lock: Avoid the child's wrong operation on the remote controller



3D air flow: The 3D airflow is able to deliver the airflow horizontally and vertically



24 Hour timer: Use the timer function to set on,or off,or from on to off,or from off to on



Auto restart: The function permits automatic return to previous peration conditions



Easy clean design: The panel is easy to wash and the airflow vents can be detached without any special tools for quick cleaning of the inside of the air conditioner



Intelligent air: With twin-blade technology ,the airflow can be adjusted not to blow directly to human body,so preventing people from the air condintioner sympton



Anti-mold filter: Catches most small particles and remove unpleasant odors effectively



Sleep mode: The setting temprature and the indoor noise can be adjusted to a more comfortable level when you set the "sleep mode"during night sleep



O<sub>2</sub> refresh: This exclusive technology can bring fresh air in and take unpleasant air out but without temprature and humidity loss



4 Fan setting: Slect the fan speed LO,MED,HI,AUTO



Entire auto mode: You can set a temprature value,with which the unit can be adjusted theoperation mode automatically



## 2 Specifications

This information was not available at the time of publication .

NOMINAL CAPACITY and NOMINAL INPUT					
For indoor units only:					
INDOOR UNITS				HSU-09H03/R(QXF)	HSU-12H03/R(QXF)
NOMINAL INPUT	Cooling	nominal	kW	0.05	0.05
	Heating	nominal	kW	0.05	0.05

NOMINAL CAPACITY and NOMINAL INPUT					
Model				HSU-09H03/R(QXF)	HSU-12H03/R(QXF)
NOMINAL CAPACITY(3-4)	Cooling(1)	norm.	kw	2.7	3.45
	Heating(2)	norm.	kw	3.0	3.8
NOMINAL INPUT	Cooling	norm	kw	0.8	1.02
	Heating	norm.	kw	0.855	1.2.
EER	Cooling			3.38	3.38
COP	Heating			3.51	3.17
ENERGY LABEL(7-8)	Cooling			---	---
	Heating			---	---
ANNUAL ENERGY CONSUMPTION(9)	Cooling		kwh	400	510

TECHNICAL SPECIFICATIONS						
INDOOR UNITS				HSU-09H03/R(QXF)	HSU-12H03/R(QXF)	
DIMENSIONS	Unit	H	mm	285	285	
		W	mm	860	860	
		D	mm	165	165	
WEIGHT	Unit		kg	10.5	10.5	
COLOR	Unit			Golden	Golden	
SOUND LEVEL	Sound pressure (cooling/heating)(5)	high	dB(A)	38/39	39/41	
		medium	dB(A)	35/36	34/36	
		low	dB(A)	30/32	30/32	
	Sound power(cooling/heating)(6)	high	dB(A)	48	48	
FAN	Air flow rate(cooling/heating)	high	m <sup>3</sup> /min	9.0/8.0	10.4/10.4	
		low	m <sup>3</sup> /min	6.5/6.5	6.5/6.5	
		super low	m <sup>3</sup> /min	-----	-----	
	Speed(cooling/heating)	steps	5steps,silent and auto			
		high	rpm	1250/1150	1350/1350	
		medium	rpm	1100/1050	1150/1150	
		low	rpm	950/950	950/950	
Type	Cross flow fan					
Motor output	W		18	18		
HEAT EXCHANGER	Type	ML fin - Φ9.52HI - XA tube				
	Row x stage x fin pitch	mm		2 x 12x1.4		
AIR FILTER	Removable/washable/mildew proof					
REMOTE CONTROLLER	YR-H82					
TEMPERATURE CONTROL	Microcomputer control					
PIPING CONNECTIONS(external diameter)	liquid	mm		6.35	6.35	
	gas	mm		9.52	12.7	
	drain	mm		16	16	
INSULATION MATERIAL	Heat insulation type			both liquid and gas pipes		

TECHNICAL SPECIFICATIONS					
OUTDOOR UNITS				HSU-09H03/R(QXF)	HSU-12H03/R(QXF)
NET DIMENSIONS (stop valve, and bottom support is not included)	Unit	H	mm	650	650
		W	mm	780	780
		D	mm	250	250
WEIGHT	Unit		kg	41	43
COLOR	Unit			white	white
SOUND LEVEL	Sound pressure(cooling/heating)(5)	high	dB(A)	46	47
	Sound power(cooling/heating)(6)	high	dB(A)	59	60
FAN	Air flow rate(cooling/heating)	high	m <sup>3</sup> /min	25.3	25.3
		low	m <sup>3</sup> /min	17.0	17.0
	Speed(cooling/heating)	high	rpm	860	860
		low	rpm	-----	-----
	Type	Propeller fan			
	Motor output		W	19	19
HEAT EXCHANGER	Type	ML - Φ9.52Hi - XA bube			
	Row x stage x fin pitch		mm	2 x 10 x 1.4	2 x 12 x 1.4
REFRIGERANT CIRCUIT	Refrigerant type			R22	R22
	Refrigerant charge		kg	1.05	1.25
	Maximum allowable distance between indoor and outdoor		m	20	20
	Maximum allowable level difference		m	10	10
	Refrigerant control		/		
COMPRESSOR	Type		Rotary Compressor		
	Model			C-RV162H01AA	PH200X2C-8FTC1
	Motor output		w	930	1100
	Oil type			SAY-56T	SUNISO 4GSD ATMOS NM56EP
	Oil charge volume		L	0.50	0.48
PIPING CONNECTIONS	liquid		mm	Φ 6.35	Φ 6.35
	gas		mm	Φ 9.52	Φ 12.7
	drain		mm	Φ 18	Φ 18
INSULATION MATERIAL	Heat insulation type			both liquid and gas pipes	

ELECTRICAL SPECIFICATIONS					
For combination indoor units+ outdoor units:			HSU-09H03/R(QXF)		HSU-12H03/R(QXF)
CURRENT	Nominal running current	cooling	A	3.3	4.4
		heating	A	4.4	5.3
	Maximum running current	cooling	A	6.3	6.3
		heating	A	7.6	7.6
	Starting current	cooling	A	22.5	22.5
		heating	A	22.5	22.5

For indoor units only:			HSU-09H03/R(QXF)	HSU-12H03/R(QXF)
POWER SUPPLY			VM	VM
NOMINAL DISTRIBUTION SYSTEM VOLTAGE	Phase		1PH	1PH
	Frequency	Hz	50	50
	Voltage	V	220~230	220~230

## NOTES

- 1 Nominal cooling capacities are based on: indoor temperature 27°CDB/19°CWB \* outdoor temperature 35°CDB \* refrigerant piping length: 5m \* level difference: 0m.
- 2 Nominal heating capacities are based on: indoor temperature 20°CDB \* outdoor temperature 7°CDB/6°CWB \* refrigerant piping length 5m (horizontal) \* level difference 0m.
- 3 Capacities are net, including a deduction for cooling (an addition for heating) for indoor fan motor heat.
- 4 Units should be selected on nominal capacity. Maximum capacity is limited to peak periods.
- 5 The sound pressure level is measured in an anechoic room at 1m distance from the unit. It is a relative value, depending on the distance and acoustic environment. For measuring conditions: please refer to item 8 of this chapter.
- 6 The sound power level is an absolute value indicating the "power" which a sound source generates.
- 7 Energy label: scale from A (most efficient) to G (less efficient).
- 8 The energy label Directive 2002/31/EC will enter into force once the relevant measurement standard will be published in the European official Standard.
- 9 Annual energy consumption: based on average use of 500 running hours per year at full load (= nominal conditions)

### 3 Remote controller lists

Model	HSU-09H03/R(QXF)	HSU-12H03/R(QXF)
YR-H82	Y	Y

### 4 Sensors lists

INDOOR UNIT		
type	Description	Qty
Room sensor	It's used for detecting room temperature	1
Pipe sensor	It's used for detecting temperature of evaporator	1

# 5 Dimensional drawings

## Indoor unit

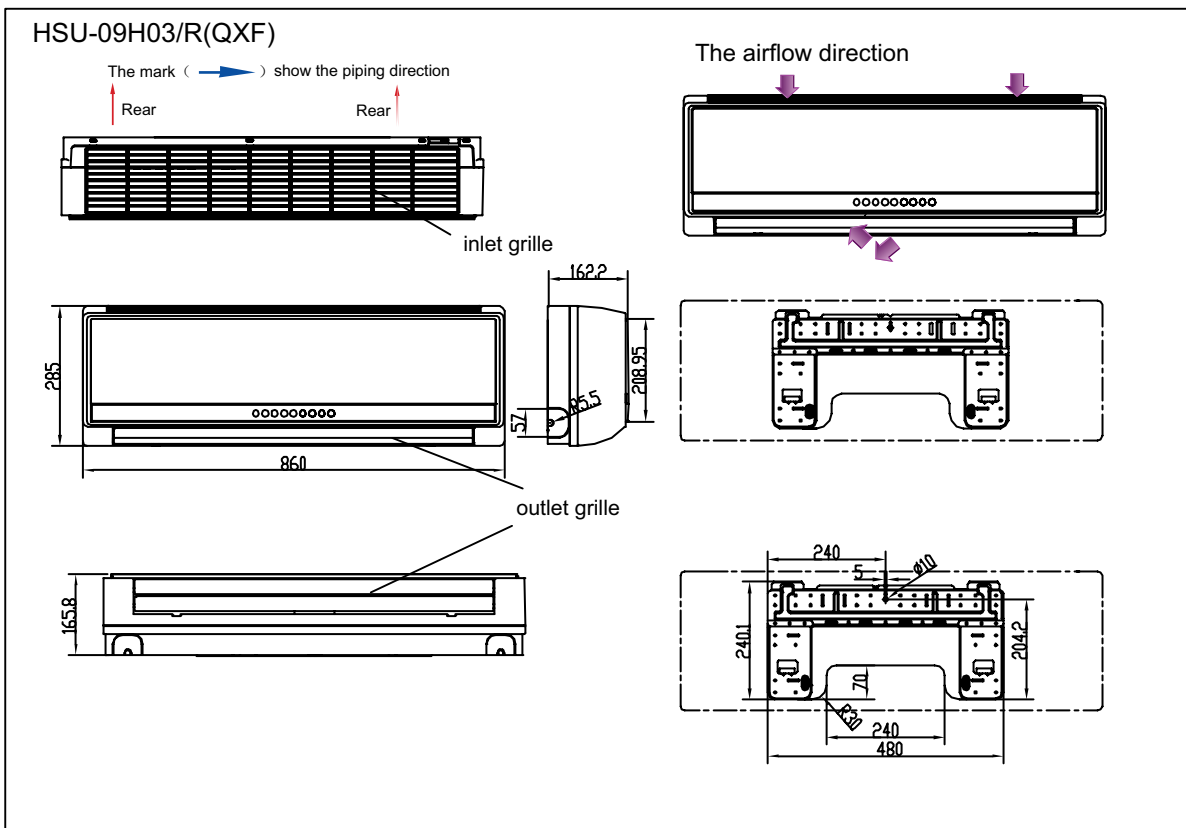

## Outdoor unit

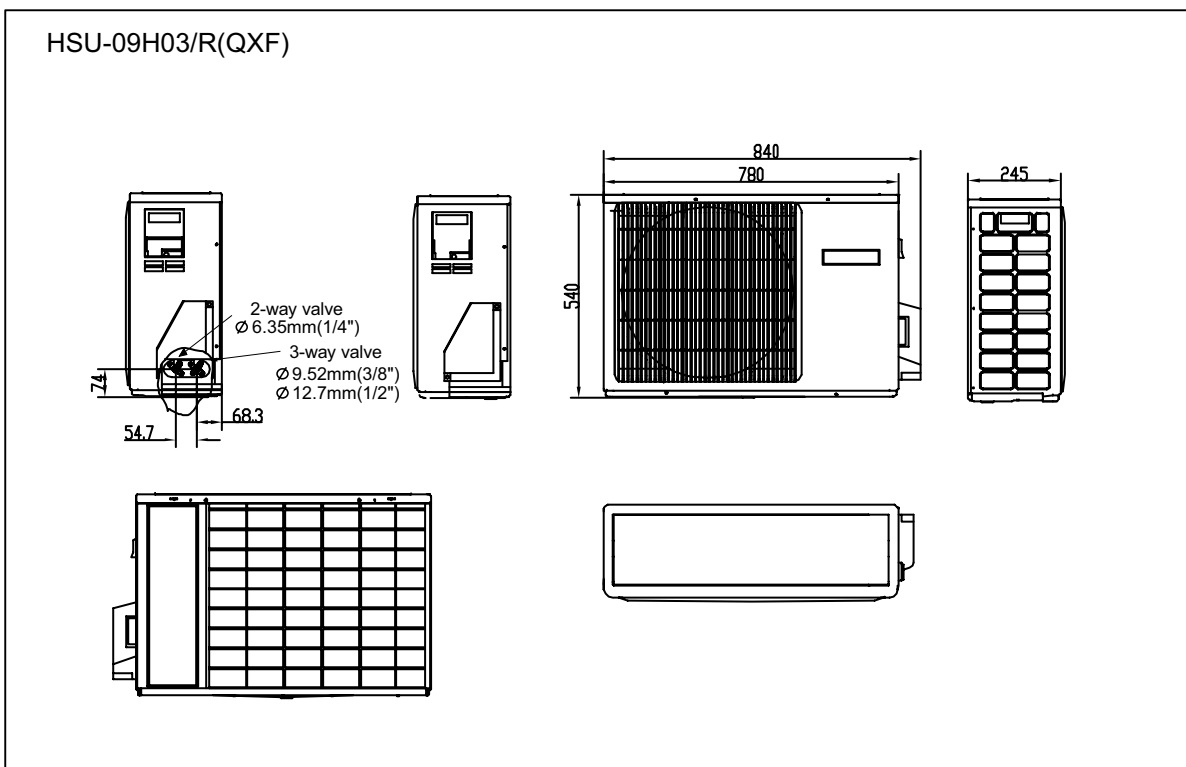



### Indoor unit

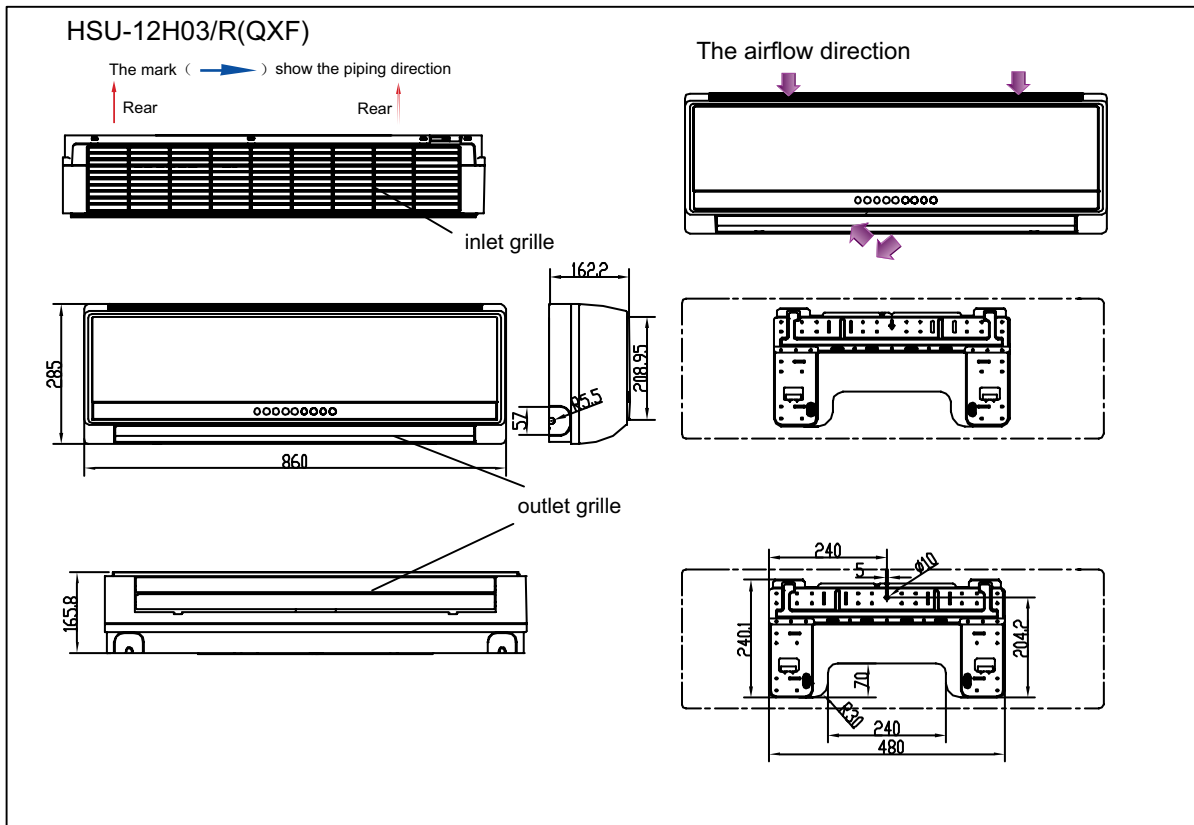

### Outdoor unit

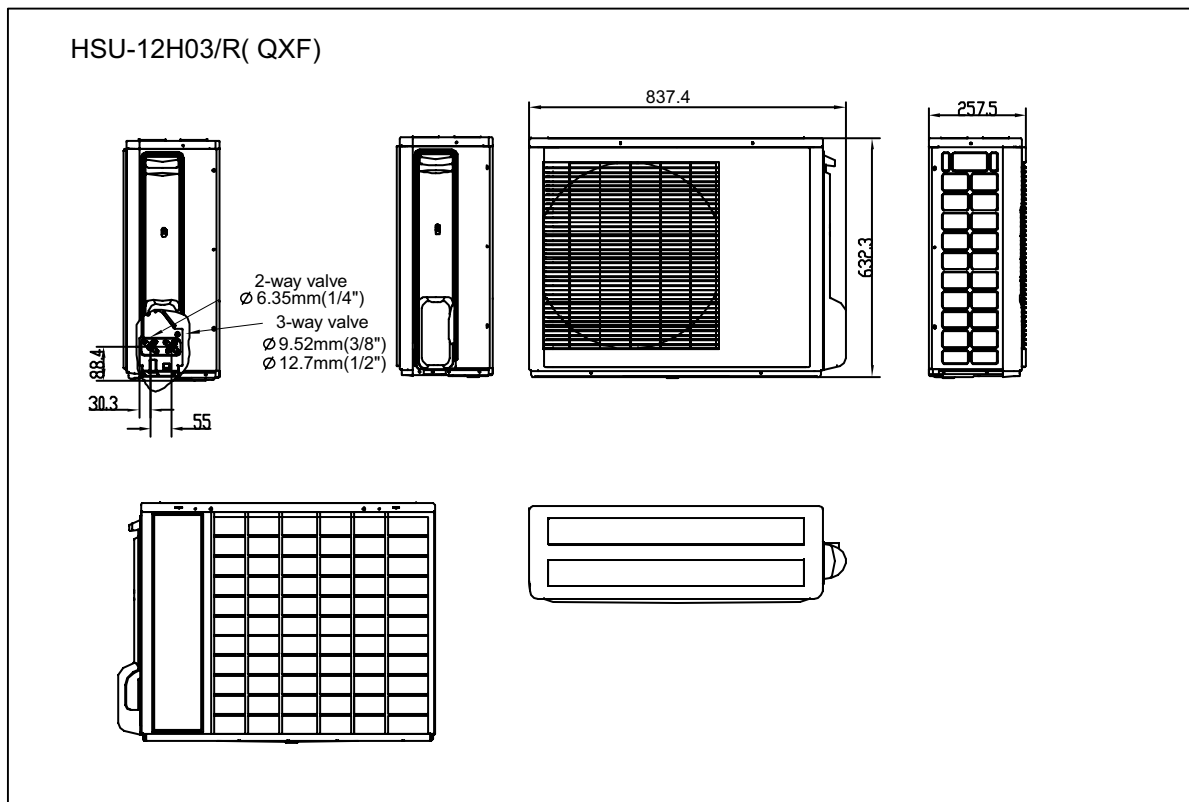

# 6 Operation range

The name of parts

Cooling

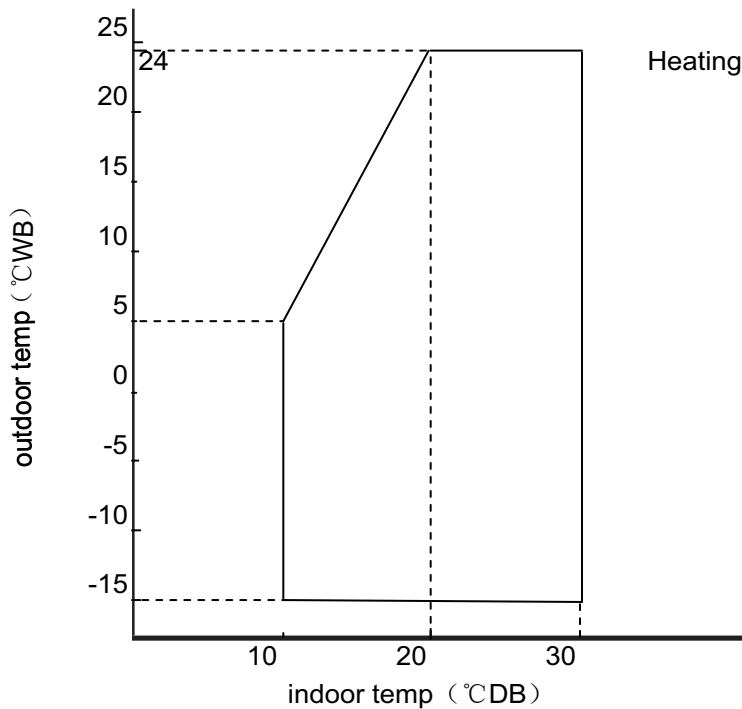
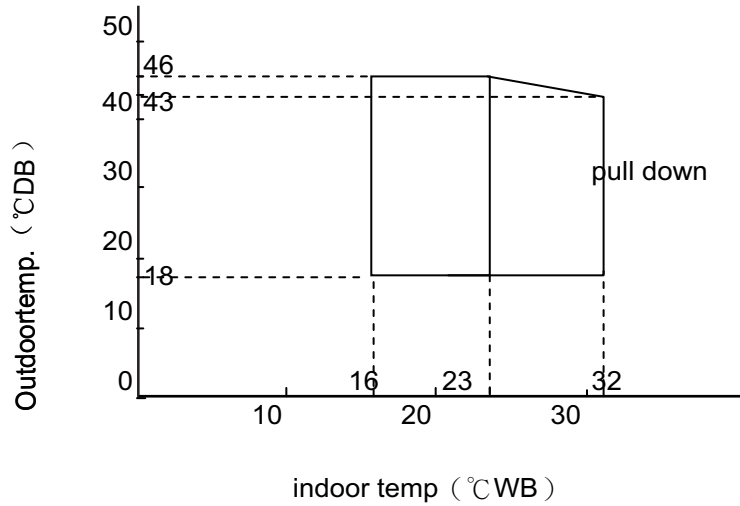

Notes:

The graphs are based on the following condition:  
 Equivalent piping length      7.5m  
 Level difference                    0m  
 Air flow rate                        high

# 7 Piping diagrams

## Cooling mode

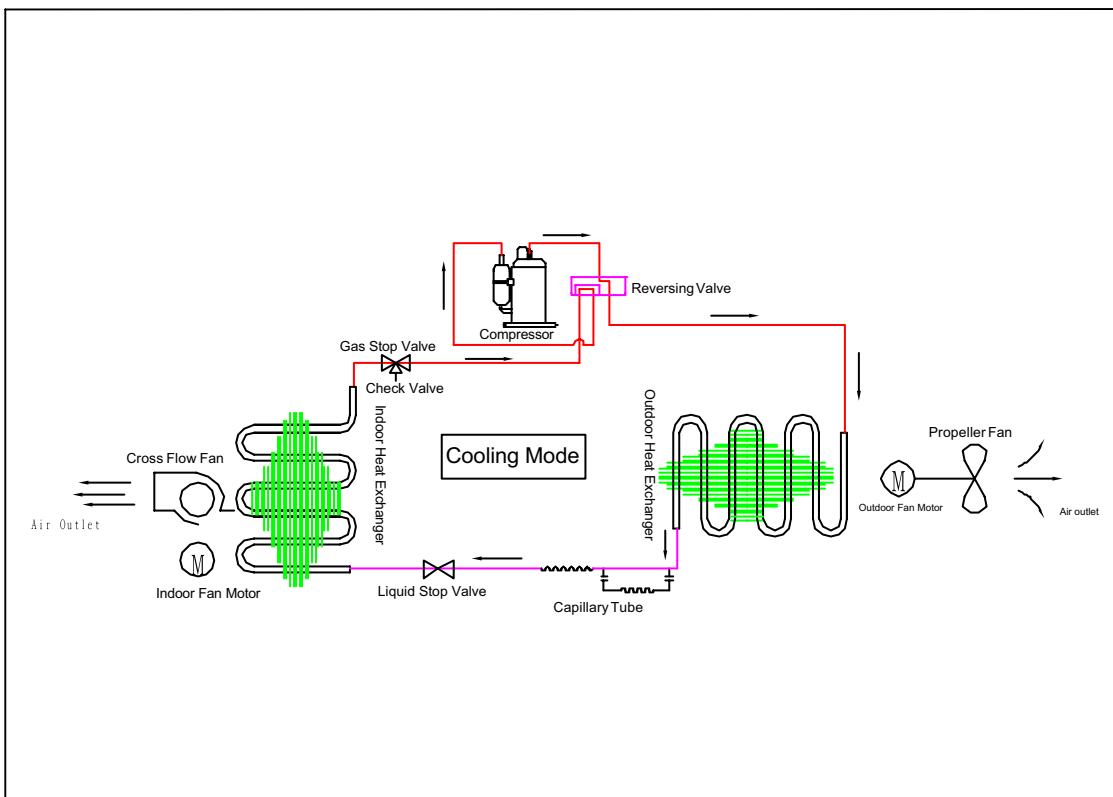

## Heating mode

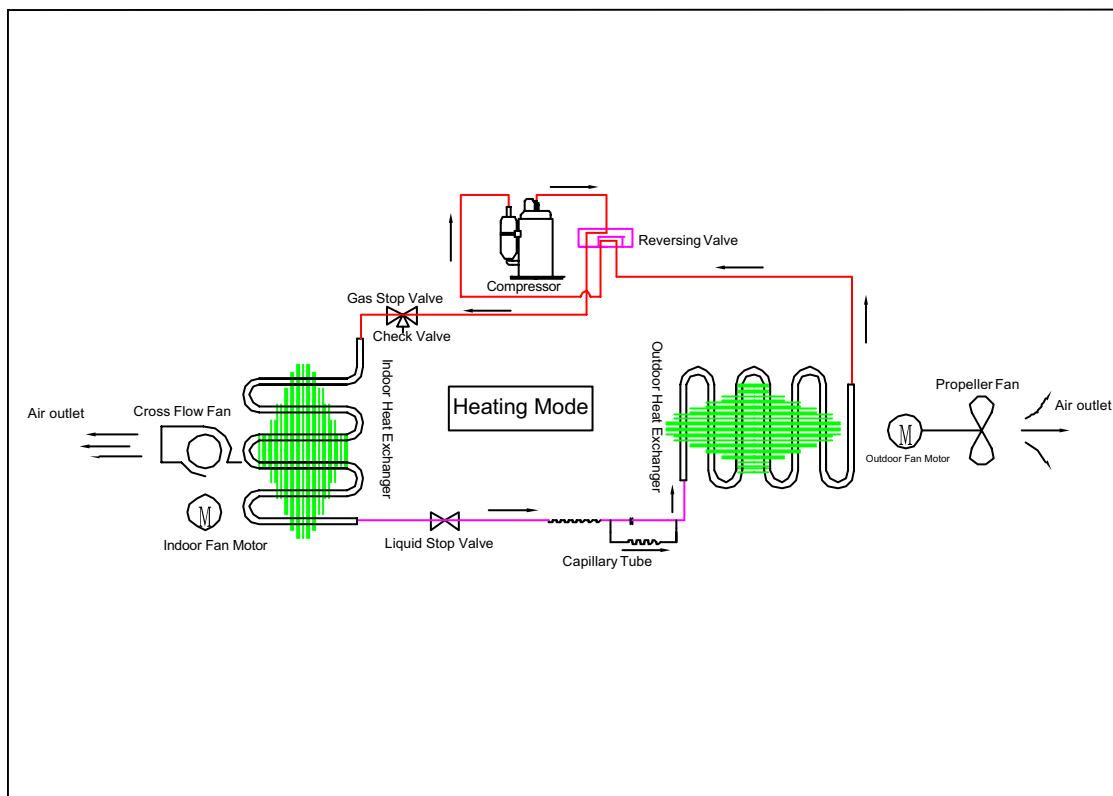

# 8 Wiring diagrams

HSU-09,12H03/R(QXF)

Indoor unit

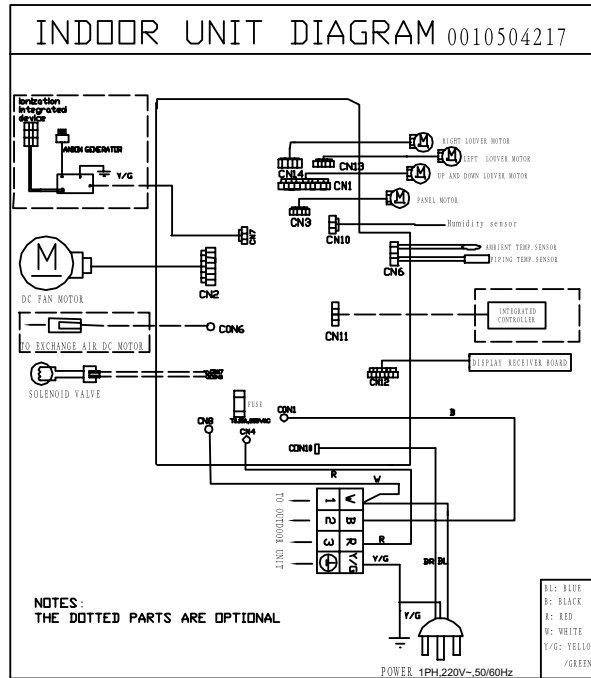

HSU-09,12H03/R(QXF)

Outdoor unit

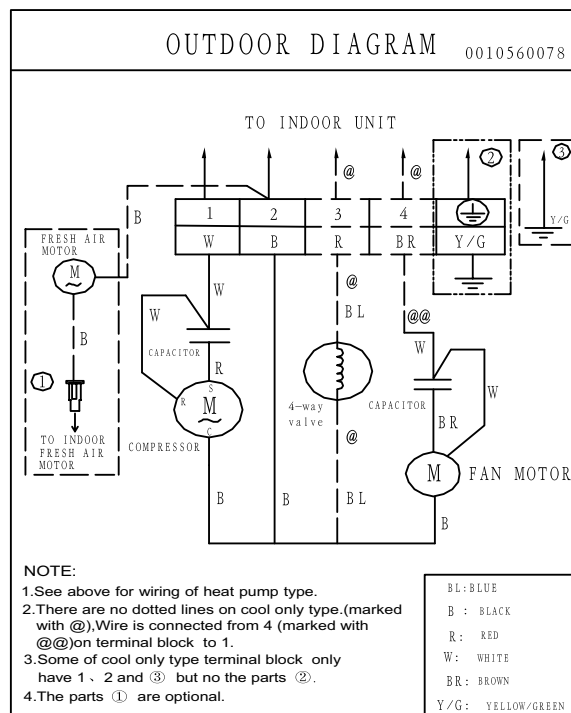

# 9 Capacity tables and curves diagrams

HSU-09H03/R(QXF) performance curves								
cooling capacity and indoor/outdoor temp.curves								
indoor temp.	outdoor temp.(humidity 46%)							
DB/WB	16 °C	20 °C	25 °C	32 °C	35 °C	40 °C	43 °C	46 °C
18/12 °C	1913	1894	1838	1801	1632	1537	1315	1259
18/14 °C	2071	2012	1952	1913	1692	1632	1396	1336
20/15 °C	2132	2074	2012	1971	1787	1682	1438	1377
22/16 °C	2246	2144	2108	2038	1847	1710	1487	1388
25/18 °C	2323	2247	2181	2136	1936	1822	1557	1428
27/19 °C	2476	2318	2244	2198	1984	1816	1603	1534
30/22 °C	2640	2499	2383	2334	2115	1990	1700	1627
32/23 °C	2716	2582	2505	2454	2223	2066	1788	1711
32/24 °C	2810	2691	2611	2557	2317	2180	1862	1782

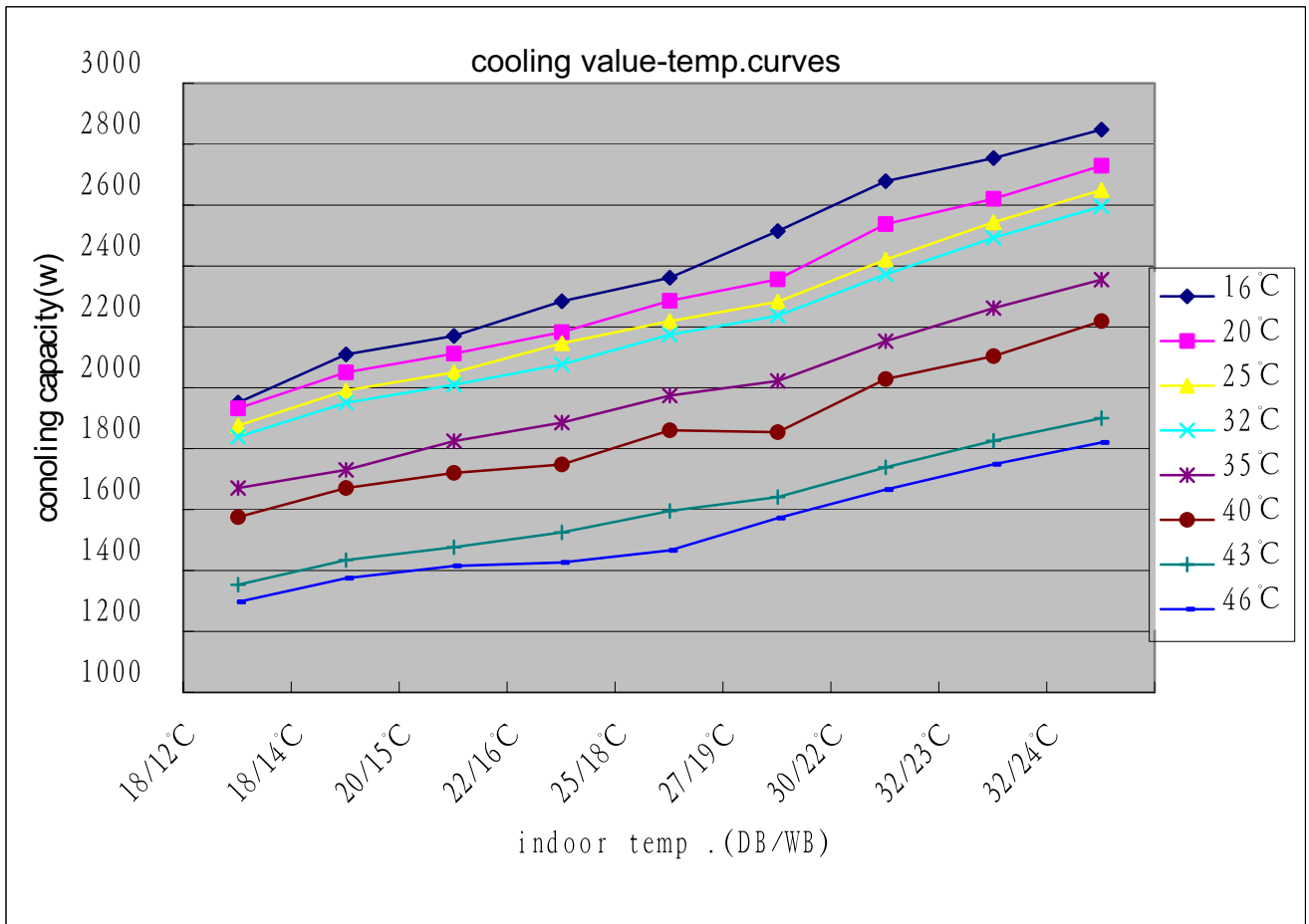

HSU-09H03/R(QXF) performance curves

Heating capacity and indoor/outdoor temp.curves

outdoor temp.	indoor temp.(humidity 46%)			
DB/WB	20/15 °C	20/14.5 °C	20/12 °C	27/18 °C
-5 °C	2331	2234	2195	2066
0 °C	2516	2445	2385	2308
5 °C	2763	2652	2534	2381
7/6 °C	2941	2763	2645	2481
10 °C	3089	2941	2852	2630
15 °C	3160	3015	2938	2689
24 °C	3262	3007	2911	2691

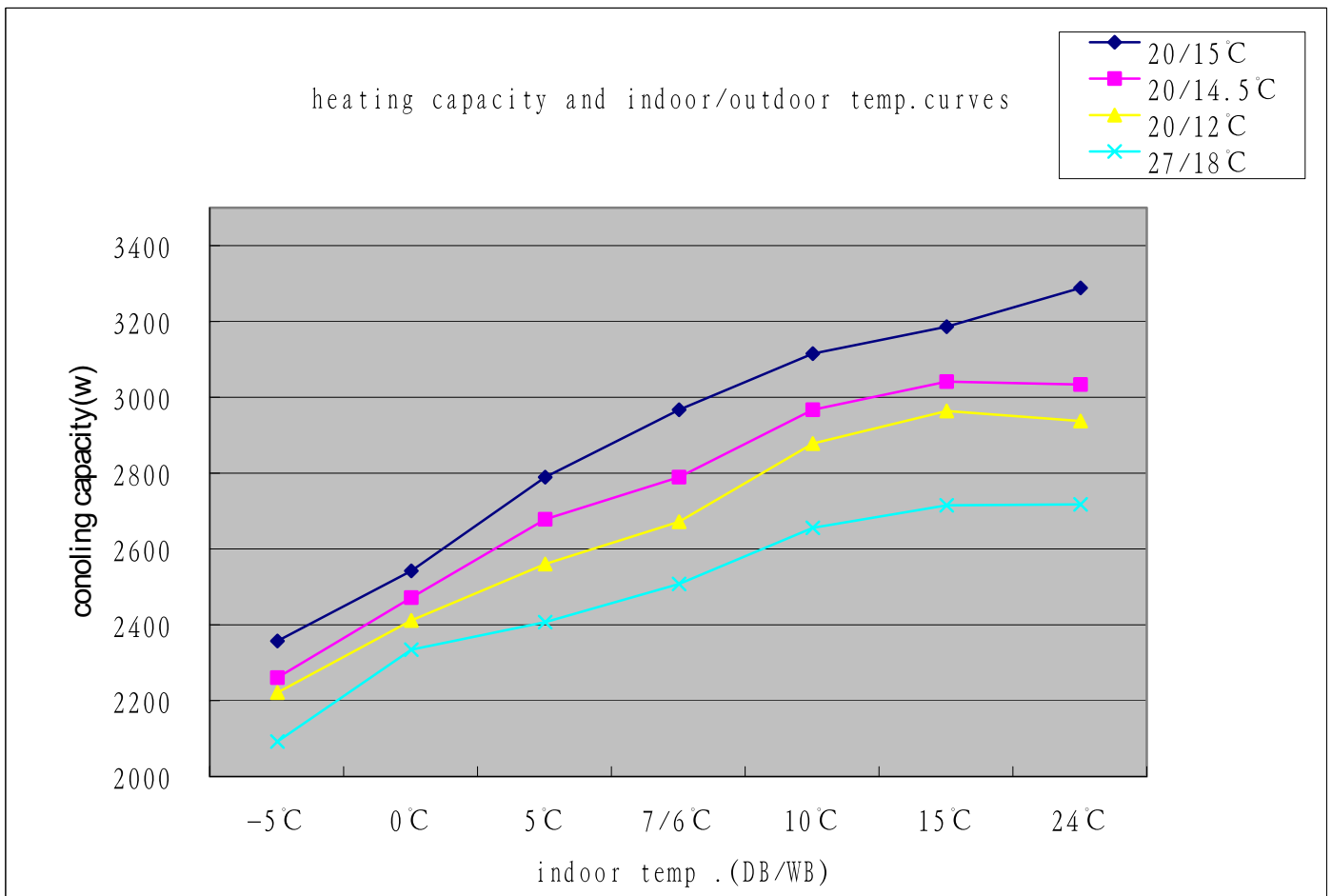

HSU-12H03/R(QXF) performance curves								
cooling capacity and indoor/outdoor temp.curves								
indoor temp.	outdoor temp.(humidity 46%)							
DB/WB	16 °C	20 °C	25 °C	32 °C	35 °C	40 °C	43 °C	46 °C
18/12 °C	2391	2368	2298	2251	2041	1822	1643	1573
18/14 °C	2589	2515	2441	2391	2115	1950	1745	1670
20/15 °C	2665	2592	2515	2464	2234	2047	1798	1721
22/16 °C	2842	2680	2635	2548	2309	2137	1858	1735
25/18 °C	3000	2809	2726	2670	2420	2278	1947	1785
27/19 °C	3156	2897	2805	2748	2577	2465	2191	1917
30/22 °C	3357	3164	2978	2917	2730	2600	2312	2034
32/23 °C	3395	3277	3132	3068	2779	2582	2352	2138
32/24 °C	3510	3325	3172	3092	2762	2561	2392	2240

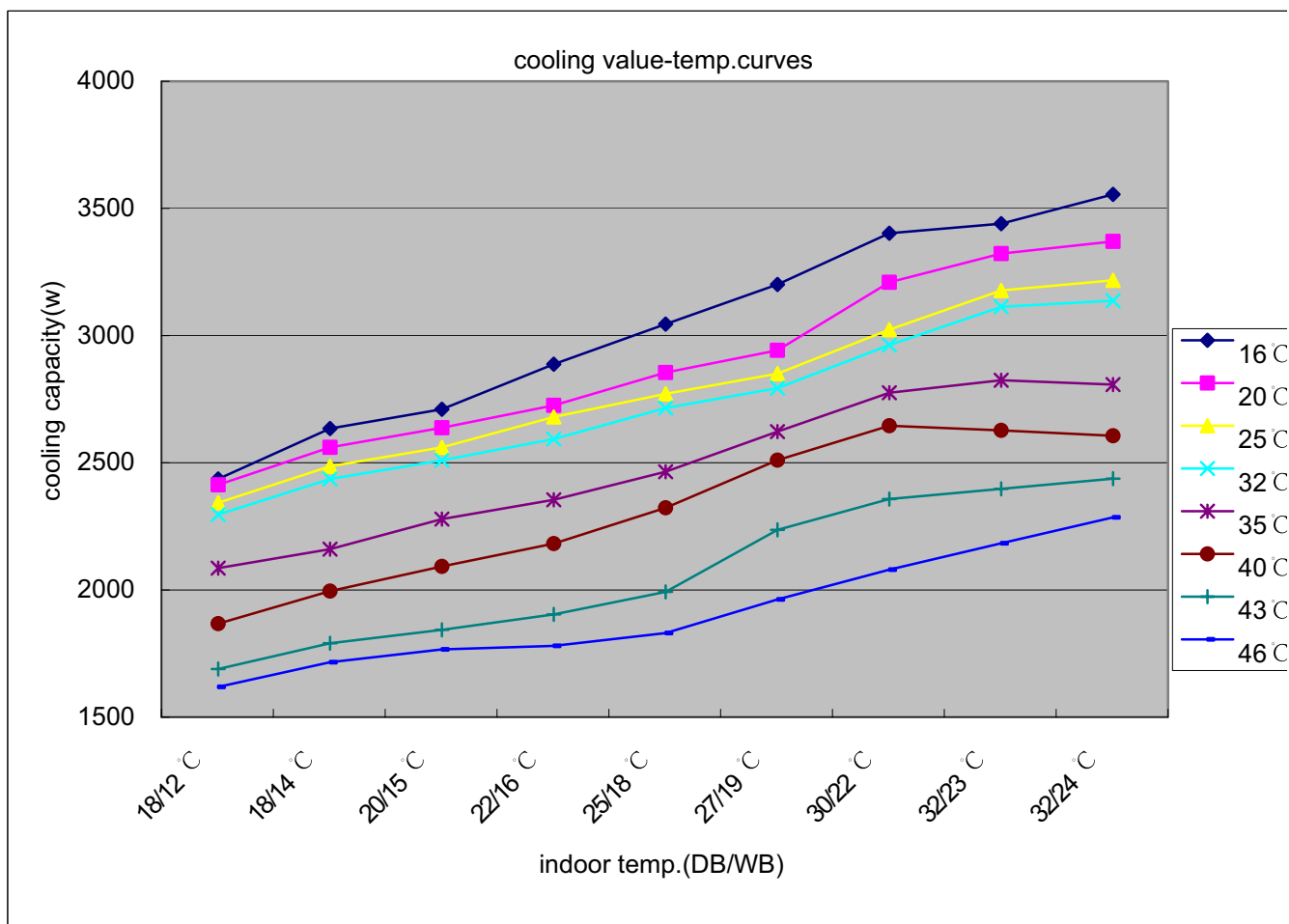

**HSU-12H03/R(QXF) performance curves**

Heating capacity and indoor/outdoor temp.curves

outdoor temp.	indoor temp.(humidity 46%)			
DB/WB	20/15 °C	20/14.5 °C	20/12 °C	27/18 °C
-5 °C	3042	2994	2851	2552
0 °C	3343	3146	3104	2787
5 °C	3507	3310	3246	2923
7/6 °C	3811	3466	3418	3196
10 °C	4020	3784	3627	3340
15 °C	4060	3888	3799	3373
24 °C	4103	3910	3761	3403

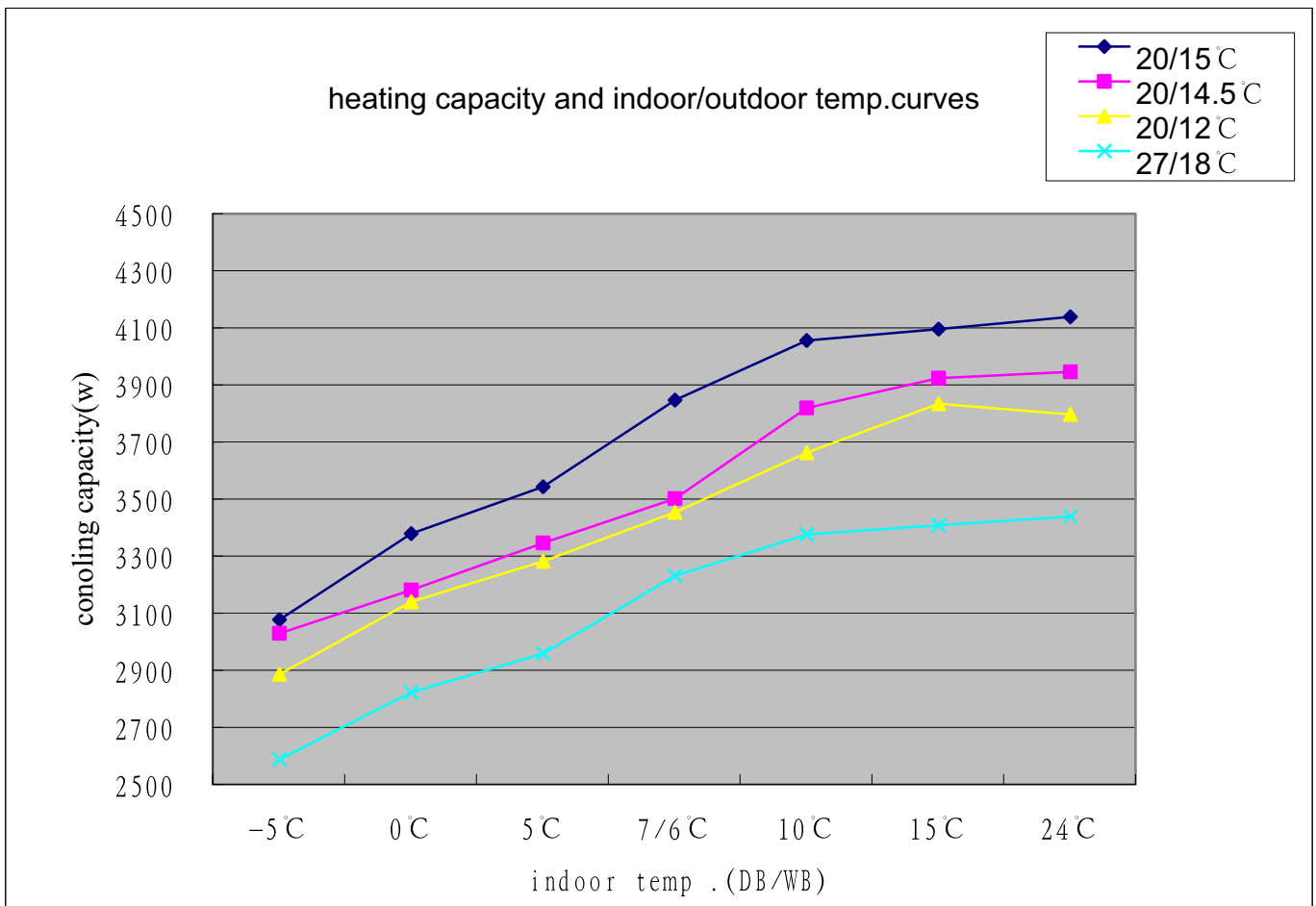

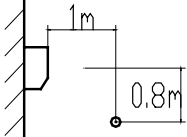

# 10 Sound level

Model	Sound pressure level			Measuring location Location of microphone 	sound power level (cooling/heating)
	220~230V, 50Hz				
	Cooling/heating				
	H	L	SL		
HSU-09H03/R(QXF)	38/40	25/29	22/26		56/58
HSU-12H03/R(QXF)	38/41	36/29	22/26		56/58

—●— INDOOR  
—■— OUTDOOR

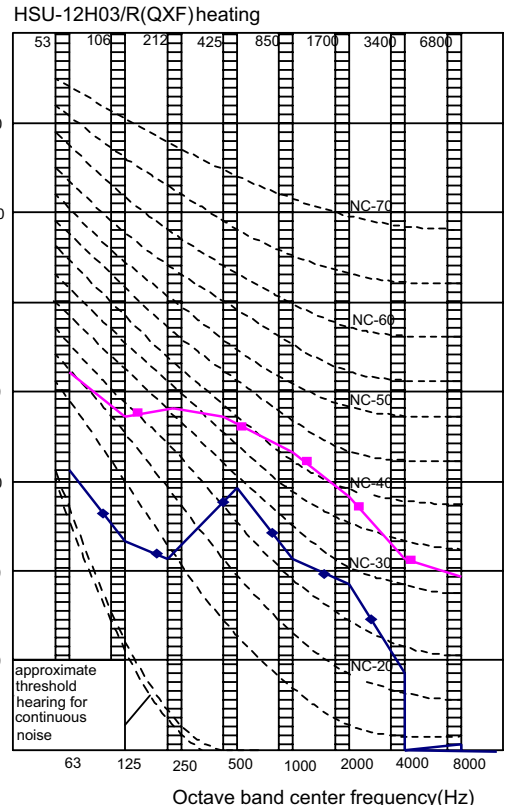
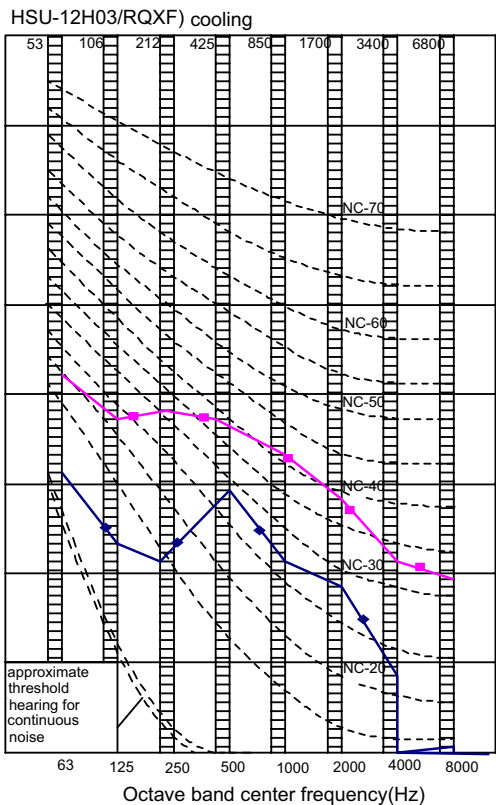
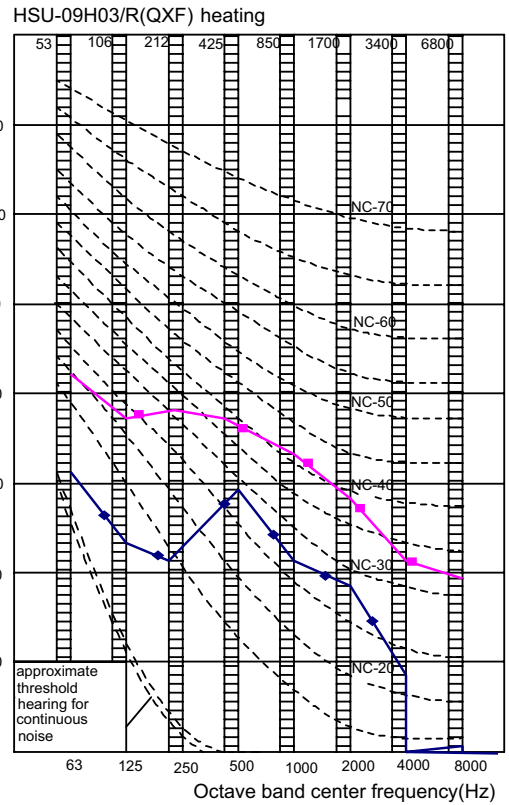
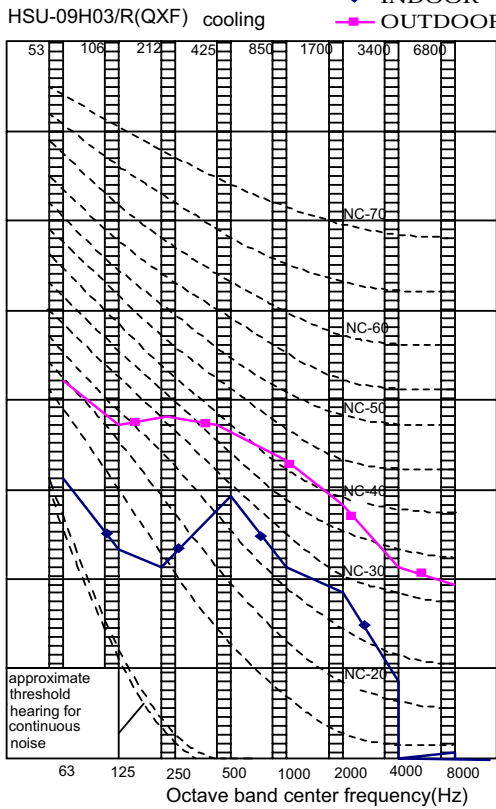

# 11 Accessories

## Standard accessories

Standard name	HSU-24C03/Z	HSU-24H03/Z
Drain hose	1	1
Plastic bag	1	1
screw assembly	1	1
Air purifier	2	2
Battery	2	2
Mounting plate	1	1
Remote controller	1	1
Installation manual	1	1
Operation manual	1	1

## 12 Control systems

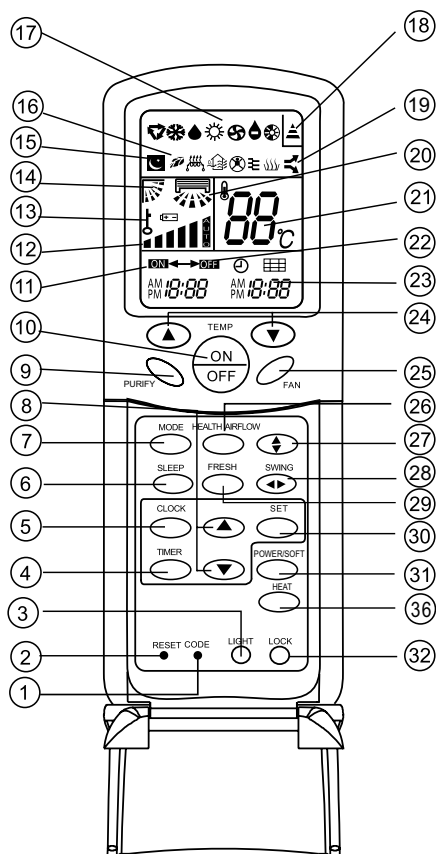

### 1.CODE

Used to select CODE A or B with a press,A or B will be displayed on LCD.

Please select A without special explanation.

### 2.RESET

When the remote controller appears abnormal, use a sharp pointed article to press this button to reset the remote controller normal.

### 3.LIGHT button

Control the lightening and extinguishing of the indoor LED display board.

### 4. TIMER button

Used to select TIMER ON, TIMER OFF, TIMER ON-OFF.

### 5. CLOCK button

Used to set correct time.

### 6. SLEEP button

Used to select sleep mode.

### 7. MODE button

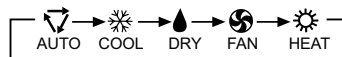

### 8. HOUR button

Used to set clock and timer setting.

### 9. Purify button

Used to set air ionization purify and healthy function.

### 10. ON/OFF button

Used for unit start and stop.

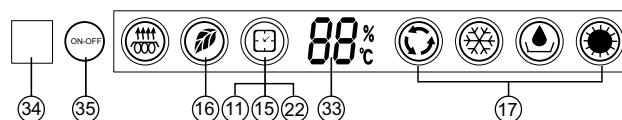

11. TIMER ON display

12. FAN SPEED display



13. LOCK display

14. SWING UP/DOWN display

15. SLEEP display

16. HEALTH display

17. Operation mode display

Operation mode	AUTO	COOL	DRY	HEAT	FAN
Remote controller					
Display board					

18. Singal sending display

19. POWER/SOFT display

20. Left/right air flow display

21. TEMP display

Remote controller: to display the TEMP. setting.

22. TIMER OFF display

23. CLOCK display

24. TEMP button

Used to select your desired temperature.

25. FAN button

Used to select fan speed: LOW, MED, HI, AUTO.

26. HEALTH AIRFLOW button

Used to set the health airflow mode.

27. SWING UP/DOWN button

Used to select up or down air sending direction.

28. SWING LEFT/RIGHT button

Used to select left/right air flow.

29. FRESH button

Use to set fresh air function.

30. SET button

Used to confirm timer and clock settings.

31. POWER/SOFT button

32. LOCK

Used to lock buttons and LCD display. If pressed, the other buttons will be disabled and the lock condition display appears. Press it once again, lock will be canceled and lock condition display disappears.

33. Ambient temp. display

When receiving the remote control signal, display the set temperature and in the rest time the room temperature is displayed and this room temperature is only for reference.

34. Remote signal receiver

35. ON-OFF button(touch key)

Used to set emergency operation and test operation.

36. HEAT button

Using for setting the fuction of Subsidiary Electric Heating.

# 13 Center of gravity

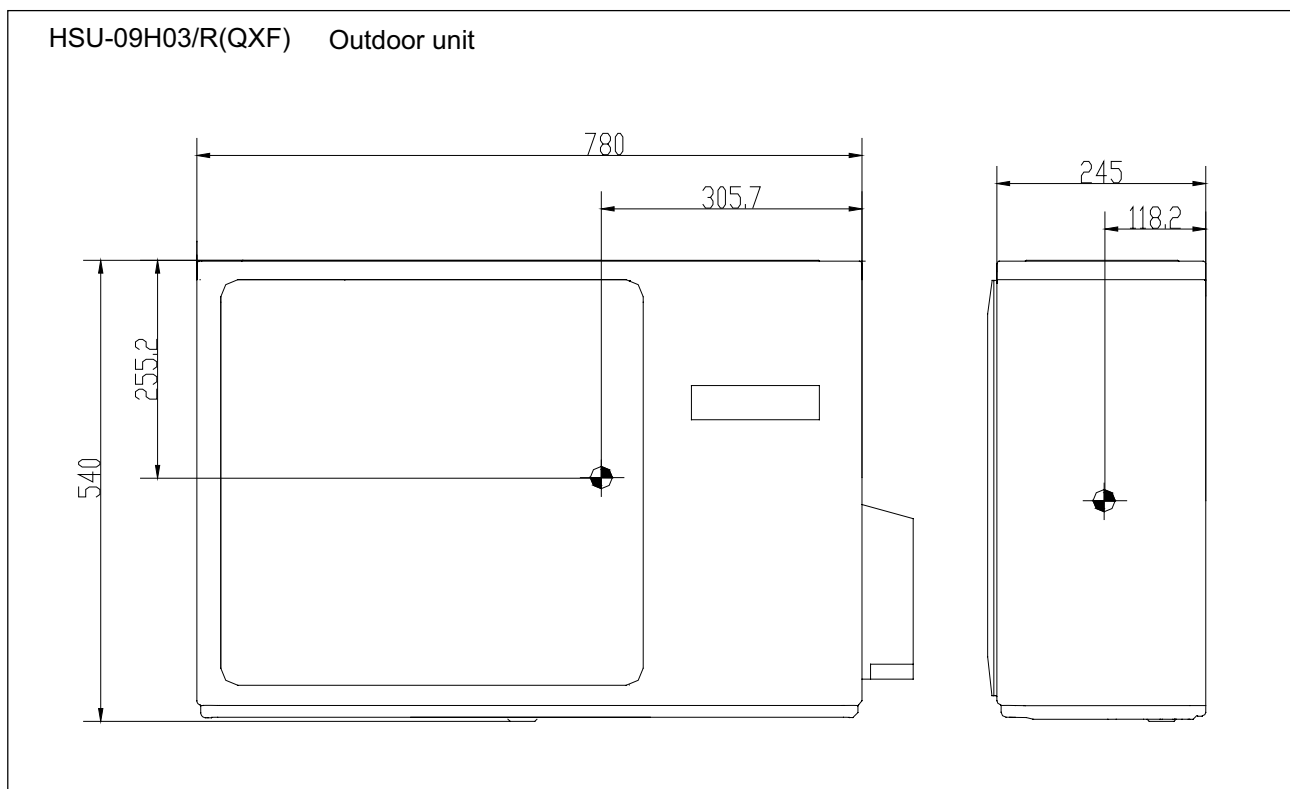
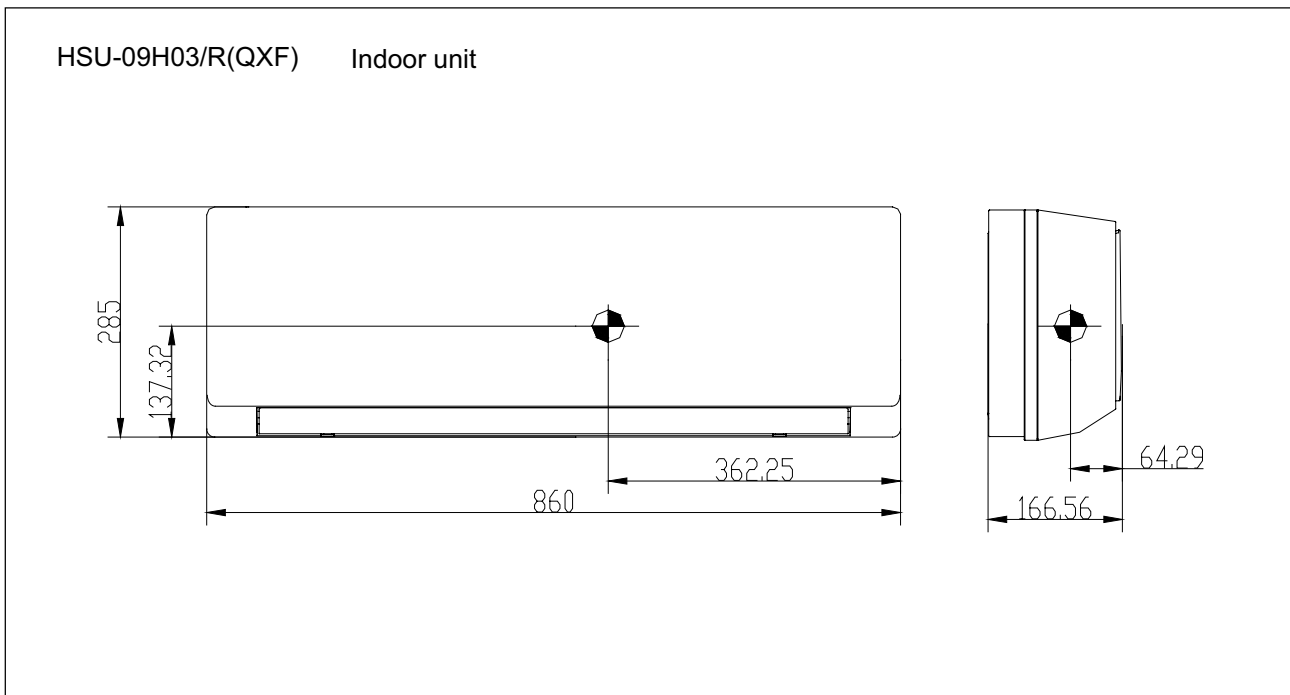

HSU-12H03/R(QXF) Indoor unit

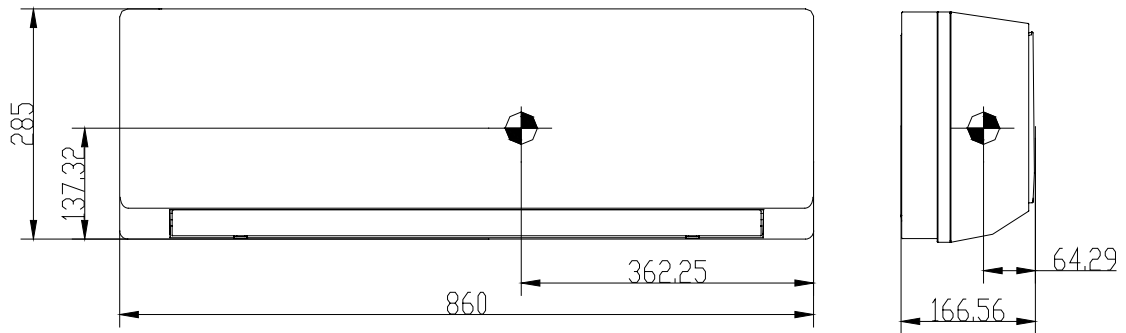

HSU-12H03/R(QXF) Outdoor unit

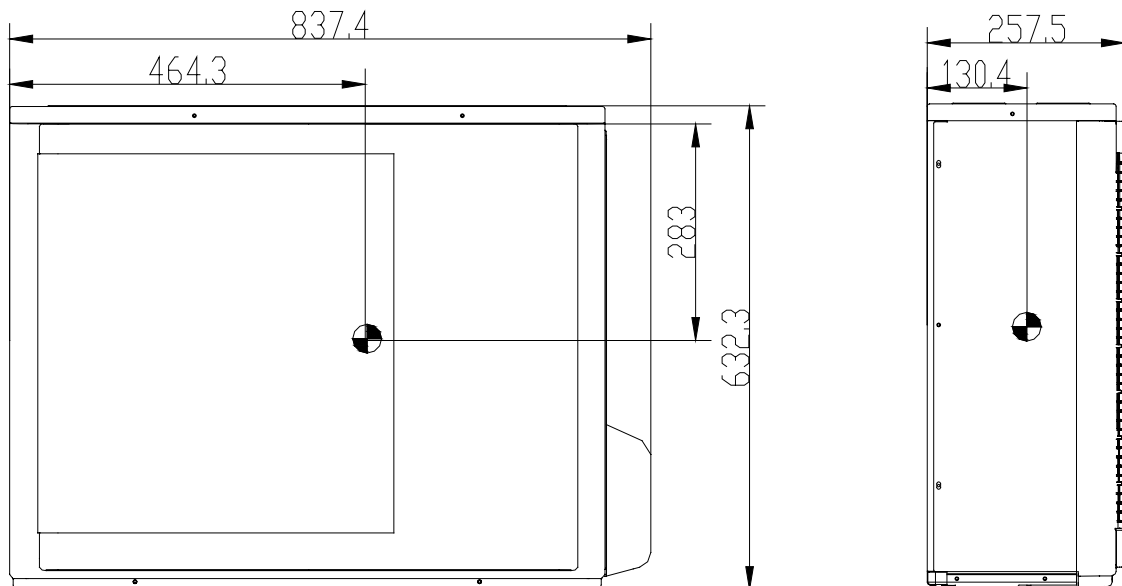

# 14 Installation

**Indoor**

- How to attach the indoor unit.  
Hook the claws of the bottom frame to the mounting plate.  
If the claws are difficult to hook ,remove the front panel.
- How to remove the indoor unit.  
Push up the marked area to release the claws .  
If it is difficult to release ,remove the front panel .

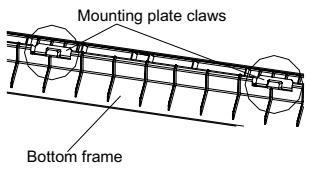

Mounting plate claws  
Bottom frame

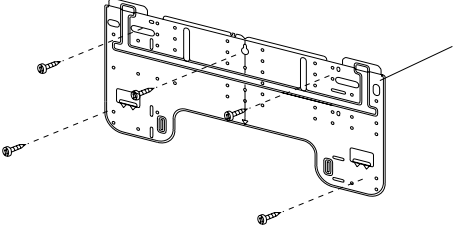

The mounting plate should be installed on a wall which can support the weight of the indoor unit.

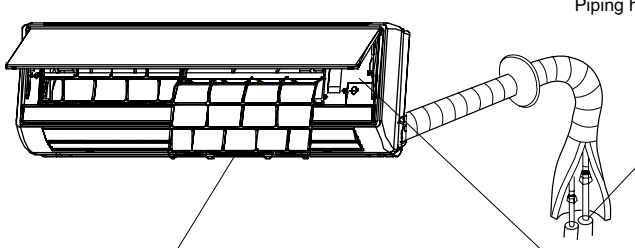

Piping hole pipe

Cut thermal insulation pipe to an appropriate length and wrap it with tape, making sure that no gap is left in the insulation pipe's cut line .

How to remove the air filter  
open the front panel and release the the claws then pull out the air filter.

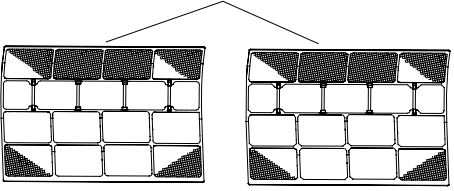

Service lid  
The service lid is an open/close type

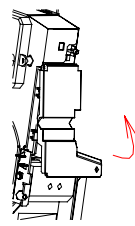

Remove the screws on the service lid.  
Slide the service lid leftward.  
Rotate the service lid upward

## Outdoor

Model	35/40 class
Max.allowable length	20m
Max.allowable height	10m
Additional refrigerant required for refrigerant pipe exceeding 5m in length	16g/m
Gas pipe	O.D. 9.52/12.7
Liquid pipe	O.D. 6.35

\*Be sure to add the proper amount of additional refrigerant. Failure to do so may result in reduced performance.

Arrangement of piping directions

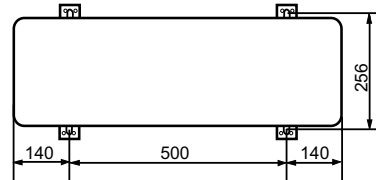
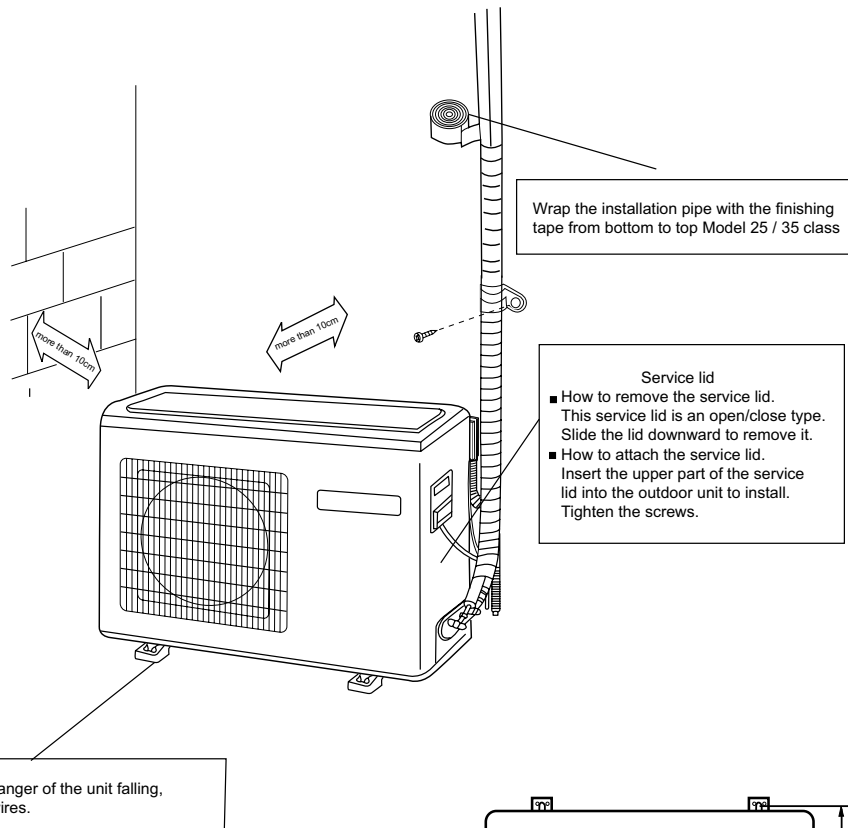
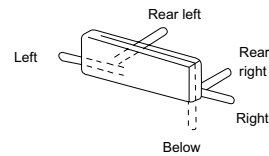

- Fix the unit to concrete or block with bolts( $\varnothing$ 10mm) and nuts firmly and horizontally.
- When fitting the unit to wall surface, roof or rooftop, fix a supporter surely with nails or wires in consideration of earthquake and strong wind. The distance between the indoor unit and the floor should be more than 2m
- If vibration may affect the house, fix the unit by attaching a vibration-proof mat.

# Sincere Forever



Haier Group

---

Haier Industrial Park, No.1, Haier Road

266101, Qingdao, China

E-mail: [hractech@haier.com](mailto:hractech@haier.com)

Tel: +86 532 87636957

[Http://www.haier.com](http://www.haier.com)

Edited by: Guo Xia

Signed by: Zhang Lizhi

Approved by: Zhu Zhenxue