



## Domestic Air conditioner

# ***TECHNICAL DATA***

## **DC Inverter**

### Wall mounted Type R-Series

HSU-09H03/R(DB)  
HSU-12H03/R(DB)

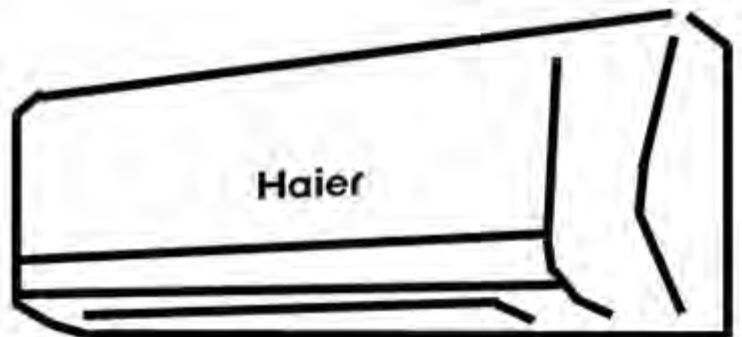

### CAUTION

1. READ THIS MANUAL CAREFULLY TO  
DIAGNOSE TROUBLE CORRECTLY  
BEFORE OFFERING SERVICE.
2. THIS MANUAL IS USED BY QUALIFIED  
APPLIANCE TECHNICIANS ONLY.
3. HAIER DOES NOT ASSUME ANY  
RESPONSIBILITY FOR PROPERTY  
DAMAGE OR PERSONAL INJURY FOR  
IMPROPER  
SERVICE PROCEDURES DONE BY ONE  
UNQUALIFIED PERSON.

# Table of Contents

<b>1. Features</b> .....	2
<b>2. Specifications</b> .....	3
<b>3. Remote controller lists</b> .....	6
<b>4. Sensors lists</b> .....	6
<b>5. Dimensional drawings</b> .....	7
<b>6. Operation range</b> .....	9
<b>7. Piping diagrams</b> .....	10
<b>8. Wiring diagrams</b> .....	11
<b>9. Capacity diagrams and curves diagrams</b> .....	12
<b>10. Sound level</b> .....	16
<b>11. Accessories</b> .....	18
<b>12. Control systems</b> .....	19
<b>13. Center of gravity</b> .....	20
<b>14. Installations</b> .....	21

# 1 Features



Healthy negative ion: make your room full of an abundance natural negative ions



Left&right flow: With specialized motor and flaps,the airflow can be adjusted



DRY function: Make dehumidifying in the room when the unit is working in the "DRY" mode



Child lock: Avoid the child's wrong operation on the remote controller



3D air flow: The 3D airflow is able to deliver the airflow horizontally and vertically



24 Hour timer: Use the timer function to set on,or off,or from on to off,or from off to on



Auto restart: The function permits automatic return to previous peration conditions



Easy clean design: The panel is easy to wash and the airflow vents can be detached without any special tools for quick cleaning of the inside of the air conditioner



Intelligent air: With twin-blade technology ,the airflow can be adjusted not to blow directly to human body,so preventing people from the air conditioner sympton



Anti-mold filter: Catches most small particles and remove unpleasant odors effectively



Sleep mode: The setting temprature and the indoor noise can be adjusted to a more comfortable level when you set the "sleep mode"during night sleep



O<sub>2</sub> refresh: This exclusive technology can bring fresh air in and take unpleasant air out but without temprature and humidity loss



4 Fan setting: Slect the fan speed LO,MED,HI,AUTO



Entire auto mode: You can set a temprature value,with which the unit can be adjusted theoperation mode automatically



## 2.Specifications

This information was not available at the time of publication .

NOMINAL CAPACITY and NOMINAL INPUT					
For indoor units only:					
INDOOR UNITS			HSU-09H03/R(DB)		HSU-12H03/R(DB)
NOMINAL INPUT	Cooling	nominal	kW	0.1	0.1
	Heating	nominal	kW	0.1	0.1

NOMINALCAPACITY and NOMINAL INPUT					
Model			HSU-09H03/R(DB)		HSU-12H03/R(DB)
NORMINAL CAPACITY(3-4)	Cooling(1)	min.~norm.~max.	kw	0.5.~2.8.~3.4.	0.5.~3.5.~4.1.
	Heating(2)	min.~norm.~max.	kw	0.5.~3.6.~4.9	0.5.~4.2.~5.3.
NORMINAL INPUT	Cooling	min.~norm.~max.	kw	0.13.~0.65.~1.1.	0.14.~0.88.~1.3.
	Heating	min.~norm.~max.	kw	0.13.~0.88.~1.4.	0.13.~1.05.~1.5.
EER	Cooling			4.31	3.98
COP	Heating			4.09	4.0
ENERGY LABEL(7-8)	Cooling			-----	-----
	Heating			-----	-----
ANNUAL ENERGY CONSUMPTION(9)	Cooling		kwh	325	440

TECHNICAL SPECIFICATIONS						
INDOOR UNITS				HSU-09H03/R(DB)	HSU-12H03/R(DB)	
DIMENSIONS	Unit	H	mm	285	285	
		W	mm	860	860	
		D	mm	165	165	
WEIGHT	Unit	kg		10.5	10.5	
COLOR	Unit			Golden	Golden	
SOUND LEVEL	Sound pressure (cooling/heating)(5)	high	dB(A)	38/40	38/41	
		medium	dB(A)	25/29	25/39	
		low	dB(A)	22/26	22/26	
	Sound power(cooling/heating)(6)	high	dB(A)	56/58	56/58	
FAN	Air flow rate(cooling/heating)	high	m <sup>3</sup> /min	12.5/11.7	13/12.5	
		low	m <sup>3</sup> /min	6.5/7	6.5/6.5	
		super low	m <sup>3</sup> /min	5.0/5.5	5.0/5.5	
	Speed(cooling/heating)	steps		5steps,silent and auto		
		high	rpm	1400/1350	1450/1400	
		medium	rpm	1175/1150	1200/1175	
		low	rpm	950/950	950/950	
Type	Cross flow fan					
Motor output	W		18	18		
HEAT EXCHANGER	Type	ML fin - Φ 9.52HI - XA tube				
	Row x stage x fin pitch	mm		2 x 12 x1.4		
AIR FILTER	Removable/washable/mildew proof					
REMOTE CONTROLLER	YR-H79					
TEMPERATURE CONTROL	Microcomputer control					
PIPING CONNECTIONS(external diameter)	liquid	mm	6.35	6.35		
	gas	mm	9.52	12.7		
	drain	mm	16	16		
INSULATION MATERIAL	Heat insulation type			both liquid and gas pipes		

TECHNICAL SPECIFICATIONS					
OUTDOOR UNITS				HSU-09H03/R(DB)	HSU-12H03/R(DB)
NET DIMENSIONS (stop valve, and bottom support is not included)	Unit	H	mm	650	650
		W	mm	780	780
		D	mm	250	250
WEIGHT	Unit		kg	43	43
COLOR	Unit			Ivory white	Ivory white
SOUND LEVEL	Sound pressure(cooling/heating)(5)	high	dB(A)	46/47	47/48
	Sound power(cooling/heating)(6)	high	dB(A)	59/59	60/60
FAN	Air flow rate(cooling/heating)	high	m <sup>3</sup> /min	30/30	30/30
		low	m <sup>3</sup> /min	23/23	23/23
	Speed(cooling/heating)	high	rpm	820/820	820/820
		low	rpm	700/700	700/700
	Type			Propeller fan	
	Motor output		W	19	19
REFRIGERANT CIRCUIT	Refrigerant type			R22	R22
	Refrigerant charge		kg	1.37	1.37
	Maximum allowable distance between indoor and outdoor		m	20	20
	Maximum allowable level difference		m	10	10
	Refrigerant control			Electronic expansion valve	
COMPRESSOR	Type			Rotary Compressor	
	Model			SHB 130FFBC	
	Motor output		w	650	650
	Oil type				
	Oil charge volume		L	0.33	0.33
PIPING CONNECTIONS	liquid		mm	6.35	6.35
	gas		mm	9.52	12.7
	drain		mm	18	18
INSULATION MATERIAL	Heat insulation type			both liquid and gas pipes	

ELECTRICAL SPECIFICATIONS					
For combination indoor units+ outdoor units:				HSU-09H03/R(DB)	HSU-12H03/R(DB)
CURRENT	Nominal running current	cooling	A	3.3	4.4
		heating	A	4.4	5.3
	Maximum running current	cooling	A	6.3	6.3
		heating	A	7.6	7.6
	Starting current	cooling	A	1.2	1.2
		heating	A	1.2	1.2

For indoor units only:			HSU-09H03/R(DB)	HSU-12H03/R(DB)
POWER SUPPLY			VM	VM
NOMINAL DISTRIBUTION SYSTEM VOLTAGE	Phase		1PH	1PH
	Frequency	Hz	50	50
	Voltage	V	230	230

## NOTES

- 1 Nominal cooling capacities are based on: indoor temperature 27°CDB/19°CWB \* outdoor temperature 35°CDB/24°CWB \* refrigerant piping length: 5m \* level difference: 0m.
- 2 Nominal heating capacities are based on: indoor temperature 20°CDB \* outdoor temperature 7°CDB/6°CWB \* refrigerant piping length 5m (horizontal) \* level difference 0m.
- 3 Capacities are net, including a deduction for cooling (an addition for heating) for indoor fan motor heat.
- 4 Units should be selected on nominal capacity. Maximum capacity is limited to peak periods.
- 5 The sound pressure level is measured in an anechoic room at 1m distance from the unit. It is a relative value, depending on the distance and acoustic environment. For measuring conditions: please refer to item 8 of this chapter.
- 6 The sound power level is an absolute value indicating the "power" which a sound source generates.
- 7 Energy label: scale from A (most efficient) to G (less efficient).
- 8 The energy label Directive 2002/31/EC will enter into force once the relevant measurement standard will be published in the European official Standard.
- 9 Annual energy consumption: based on average use of 500 running hours per year at full load (= nominal conditions)

### 3 Remote controller lists

Model	HSU-09H03/R(DB)	HSU-12H03/R(DB)
YR-H79	Y	Y

### 4 Sensors lists

INDOOR UNIT		
type	Description	Qty
Room sensor	It's used for detecting room temperature	1
Pipe sensor	It's used for detecting temperature of evaporator	1

OUTDOOR UNIT		
type	Description	Qty
Ambient sensor	It's used for detecting temperature outdoor side	1
Suction sensor	It's used for detecting suction pipe temperature of compressor to adjust gas flowing	1
Defrosting sensor	It's used for controlling outdoor defrosting at heating mode	1
Discharging sensor	It's used for protecting compressor in case of over-heat	1

# 5 Dimensional drawings

## Indoor unit

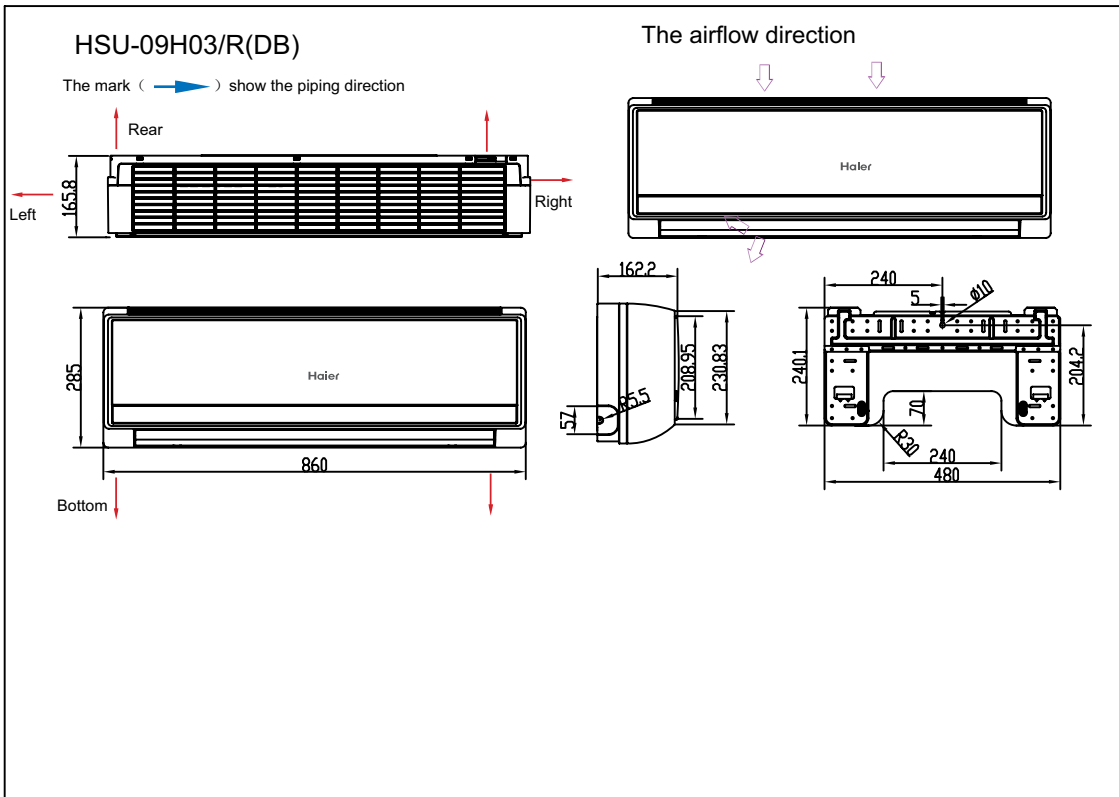

## Outdoor unit

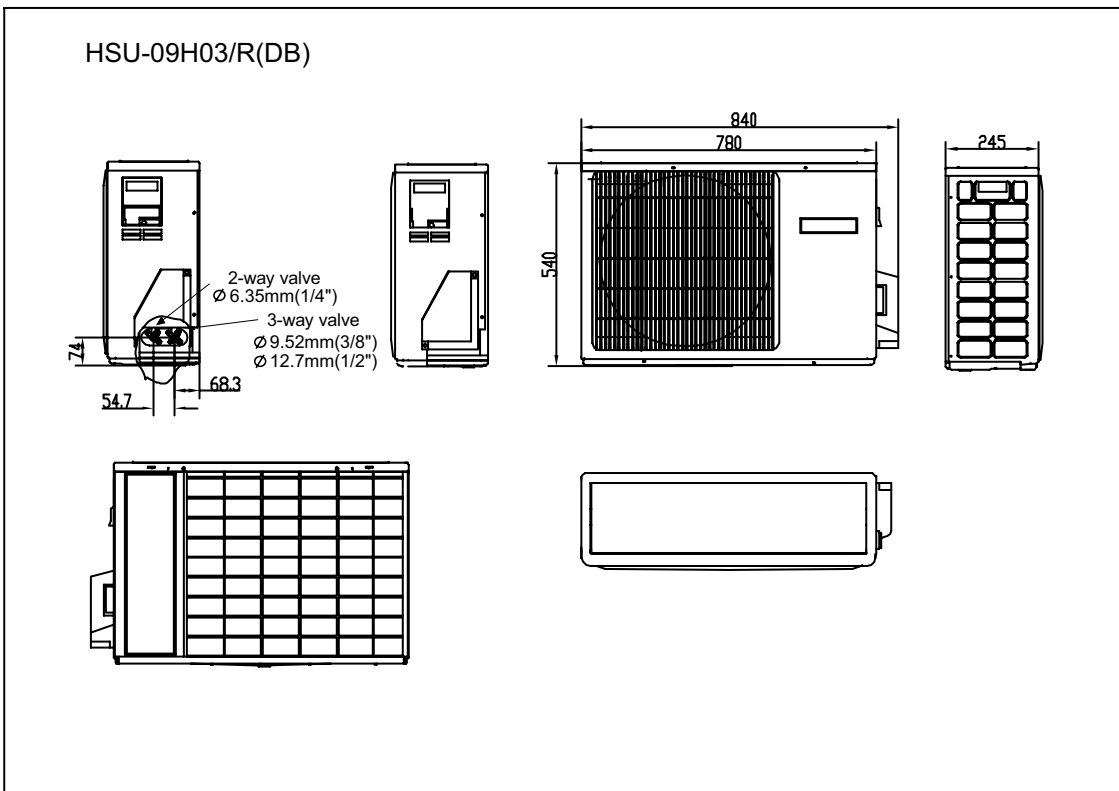





# 6 Operation range

Cooling

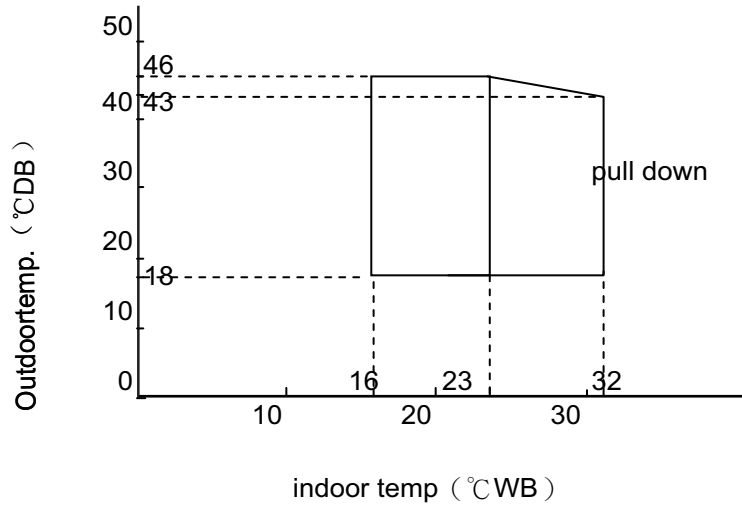

Heating

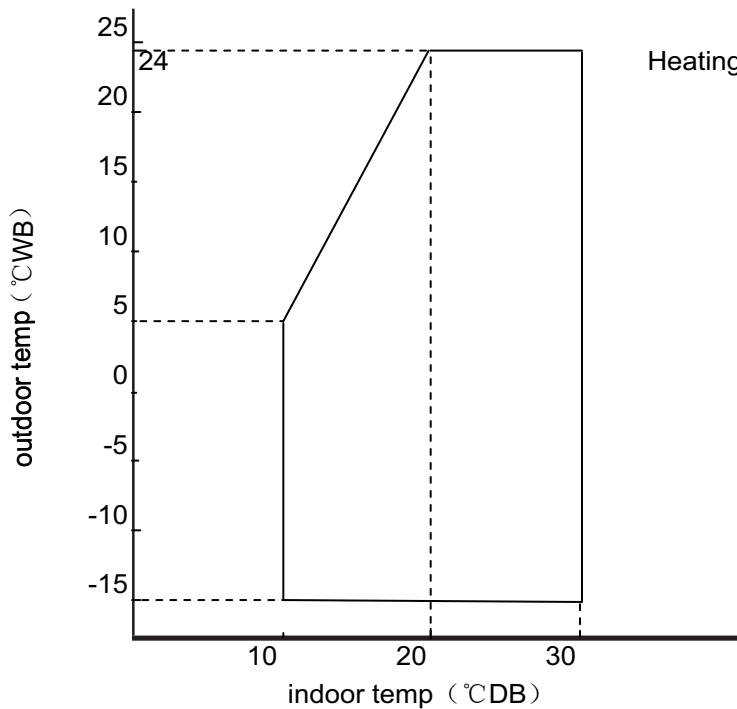

Notes:

- The graphs are based on the following condition:
- Equivalent piping length      7.5m
- Level difference                    0m
- Air flow rate                        high

# 7 Piping diagrams

## Cooling mode

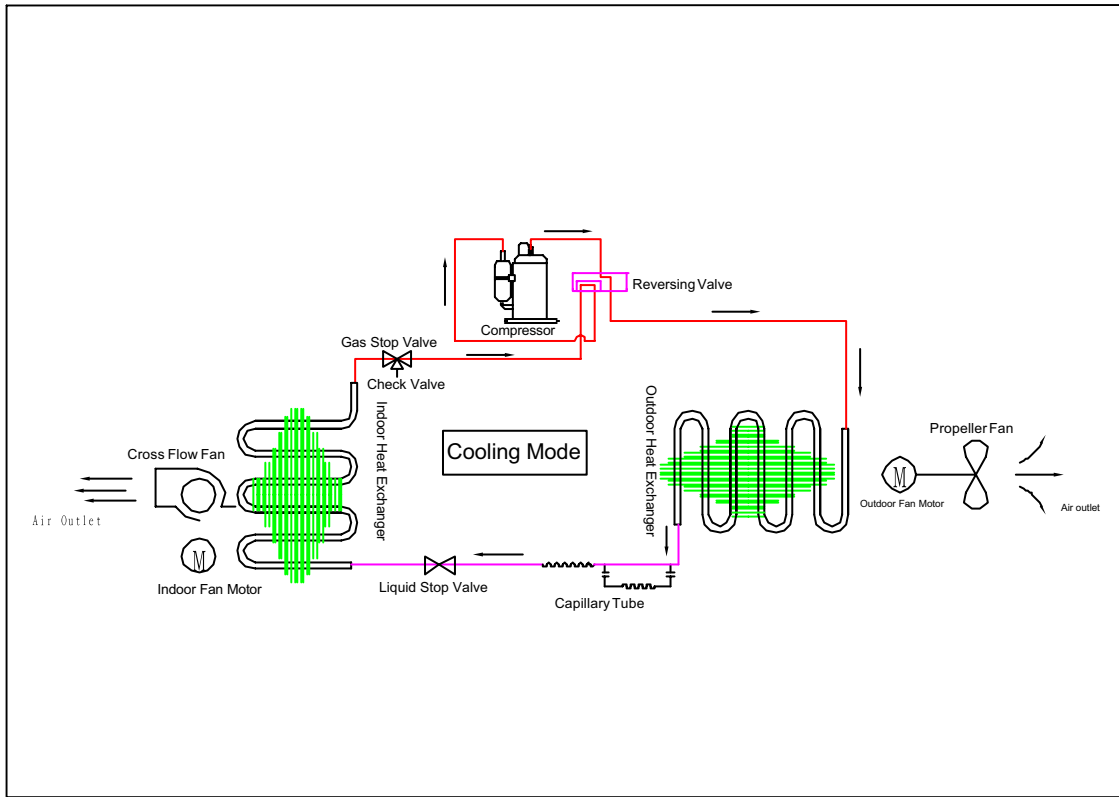

## Heating mode

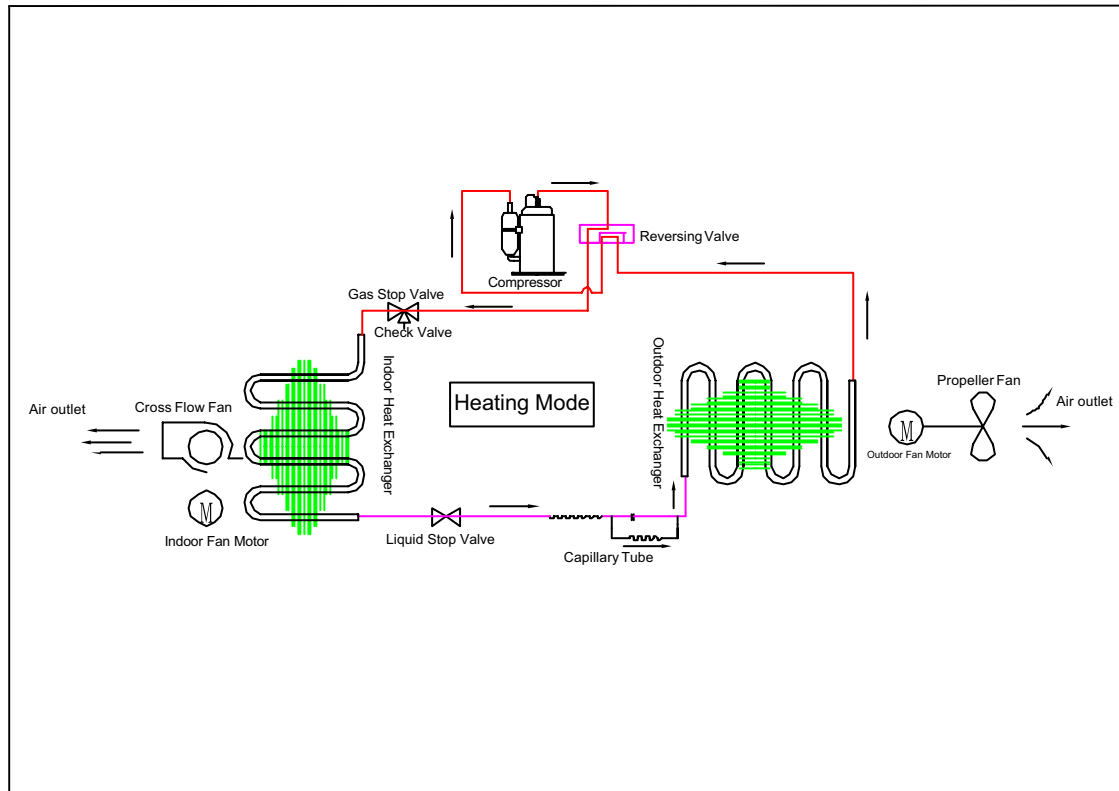

# 8 Wiring diagrams

HSU-09,1203/R(DB)  
Indoor unit

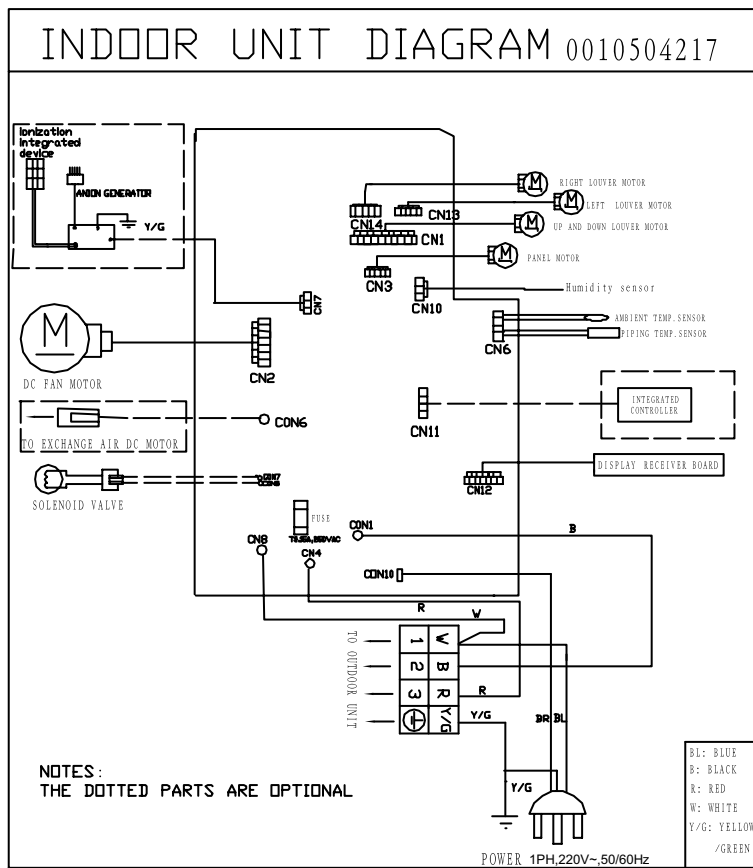

HSU-09,12H03/R(DB)  
Outdoor unit

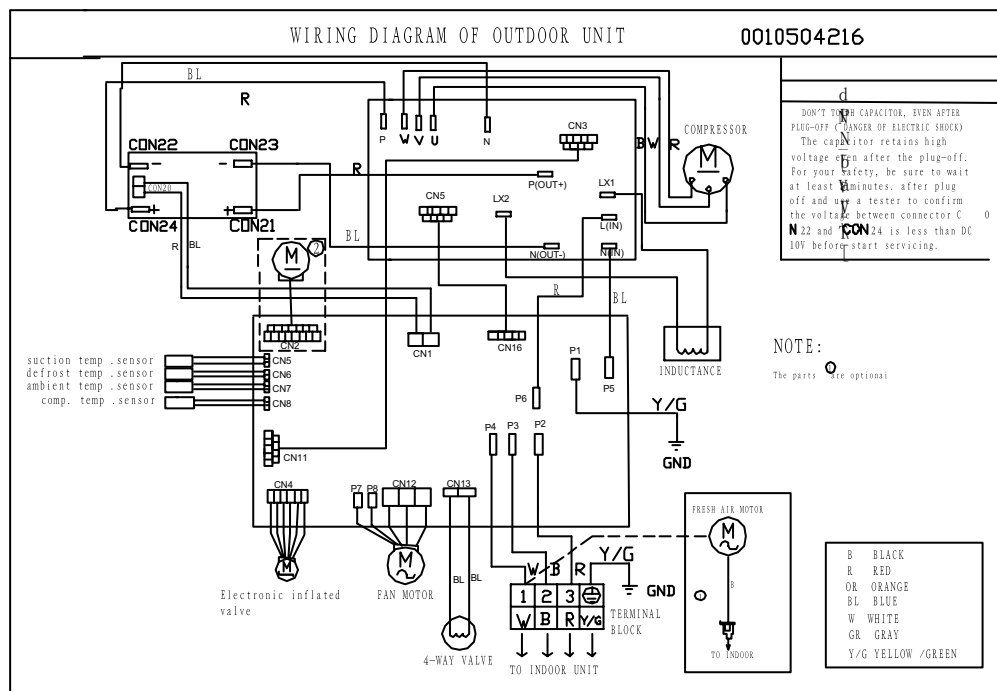

# 9 Capacity tables and curves diagrams

HSU-09H03/R(DB) performance curves								
cooling capacity and indoor/outdoor temp.curves								
indoor temp.	outdoor temp.(humidity 46%)							
DB/WB	16 °C	20 °C	25 °C	32 °C	35 °C	40 °C	43 °C	46 °C
18/12 °C	2391	2368	2298	2251	2041	1921	1643	1573
18/14 °C	2589	2515	2441	2391	2115	2041	1745	1670
20/15 °C	2665	2592	2515	2464	2234	2103	1798	1721
22/16 °C	2807	2680	2635	2548	2309	2137	1858	1735
25/18 °C	2904	2809	2726	2670	2420	2278	1947	1785
27/19 °C	3095	2897	2805	2748	2480	2270	2003	1917
30/22 °C	3300	3124	2978	2917	2643	2488	2126	2034
32/23 °C	3395	3228	3132	3068	2779	2582	2234	2138
32/24 °C	3512	3364	3263	3196	2896	2725	2328	2227

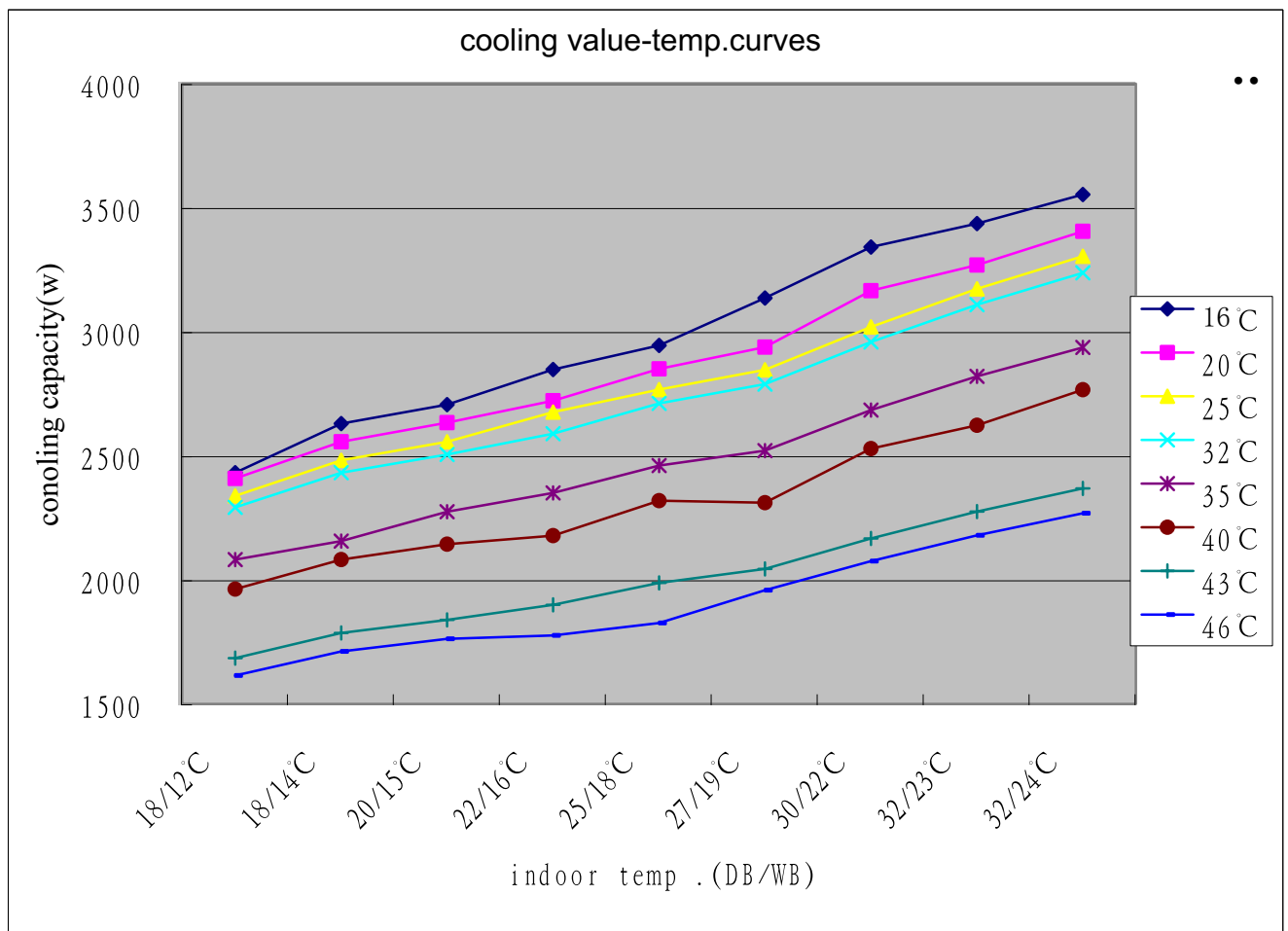

HSU-09H03/R(DB) performance curves			
Heating capacity and indoor/outdoor temp. table			
Outdoor temp. DB/WB(°C)	Indoor temp.(humidity 46%)		
	15	20	25
-10	2146	1662	1431
-5	2343	1973	1719
5	2643	2354	1881
7/6	2874	2712	2308
15	3160	2978	2618
20	3672	3324	2845
25	3866	3762	3027

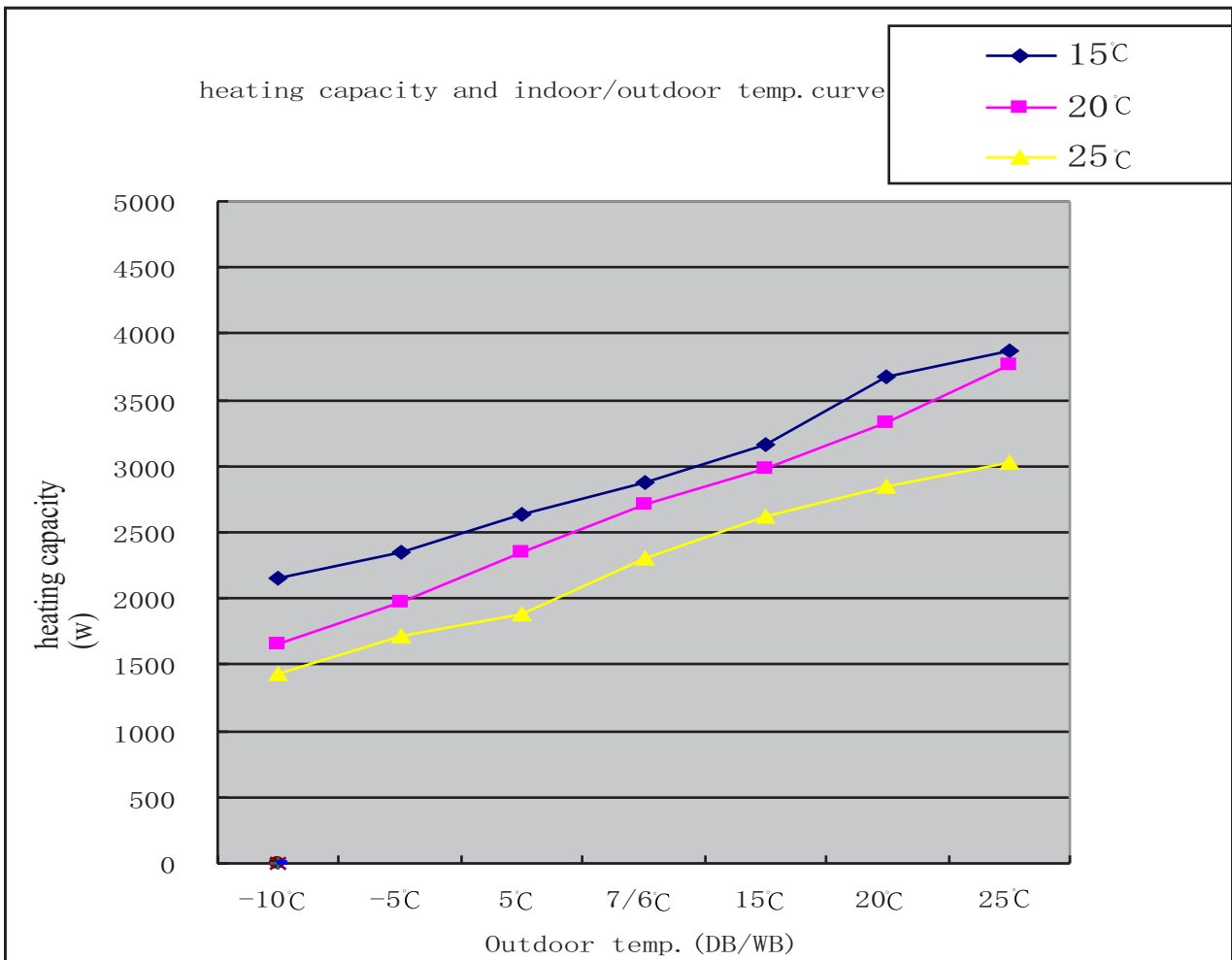

HSU-12H03/R(DB) performance curves								
cooling capacity and indoor/outdoor temp.curves								
indoor temp.	outdoor temp.(humidity 46%)							
DB/WB	18 C	20 C	25 C	32 C	35 C	40 C	43 C	46 C
18/12 C	3180	3149	3056	2994	2714	2556	2186	2093
18/14 C	3443	3345	3246	3180	2813	2714	2321	2221
20/15 C	3544	3448	3346	3277	2971	2797	2391	2289
22/16 C	3600	3565	3505	3389	3071	2842	2472	2308
25/18 C	3862	3736	3625	3551	3218	3029	2589	2374
27/19 C	3983	3853	3731	3655	3298	3019	2664	2550
30/22 C	4123	4083	3961	3880	3516	3309	2827	2706
32/23 C	4382	4293	4165	4080	3696	3434	2972	2844
32/24 C	4518	4474	4340	4251	3851	3625	3096	2962

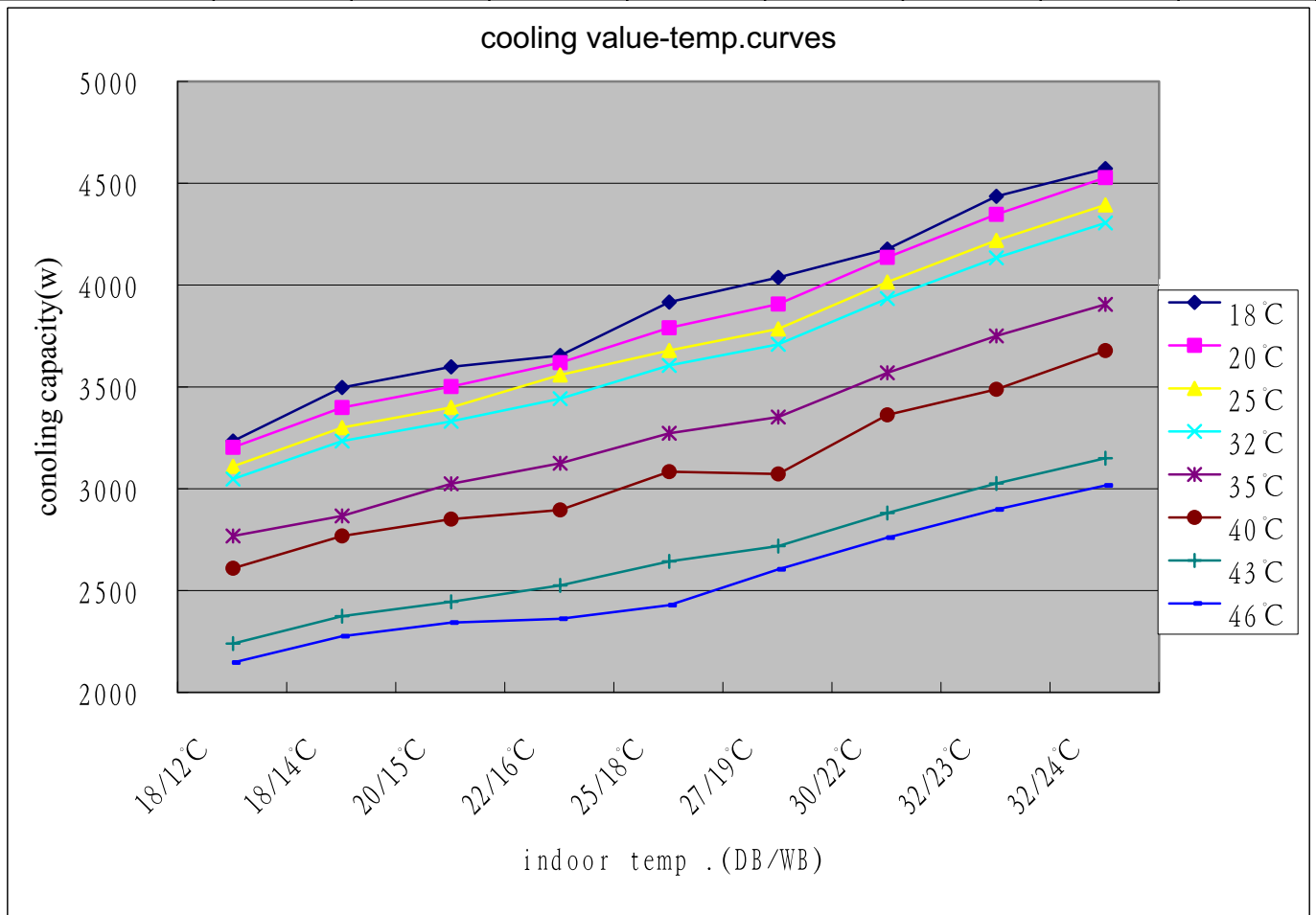

HSU-12H03/R(DB) performance curves				
heating capacity and indoor/outdoor temp.curves				
outdoor temp.	indoor temp.(humidity 46%)			
DB/WB	20/15 °C	20/14.5 °C	20/12 °C	27/18 °C
-5 °C	3937	3875	3690	3304
0 °C	4328	4072	4018	3607
5 °C	4540	4285	4202	3784
7/6 °C	4933	4487	4424	4137
10 °C	5203	4897	4695	4323
15 °C	5255	5033	4917	4366
24 °C	5311	5062	4868	4405

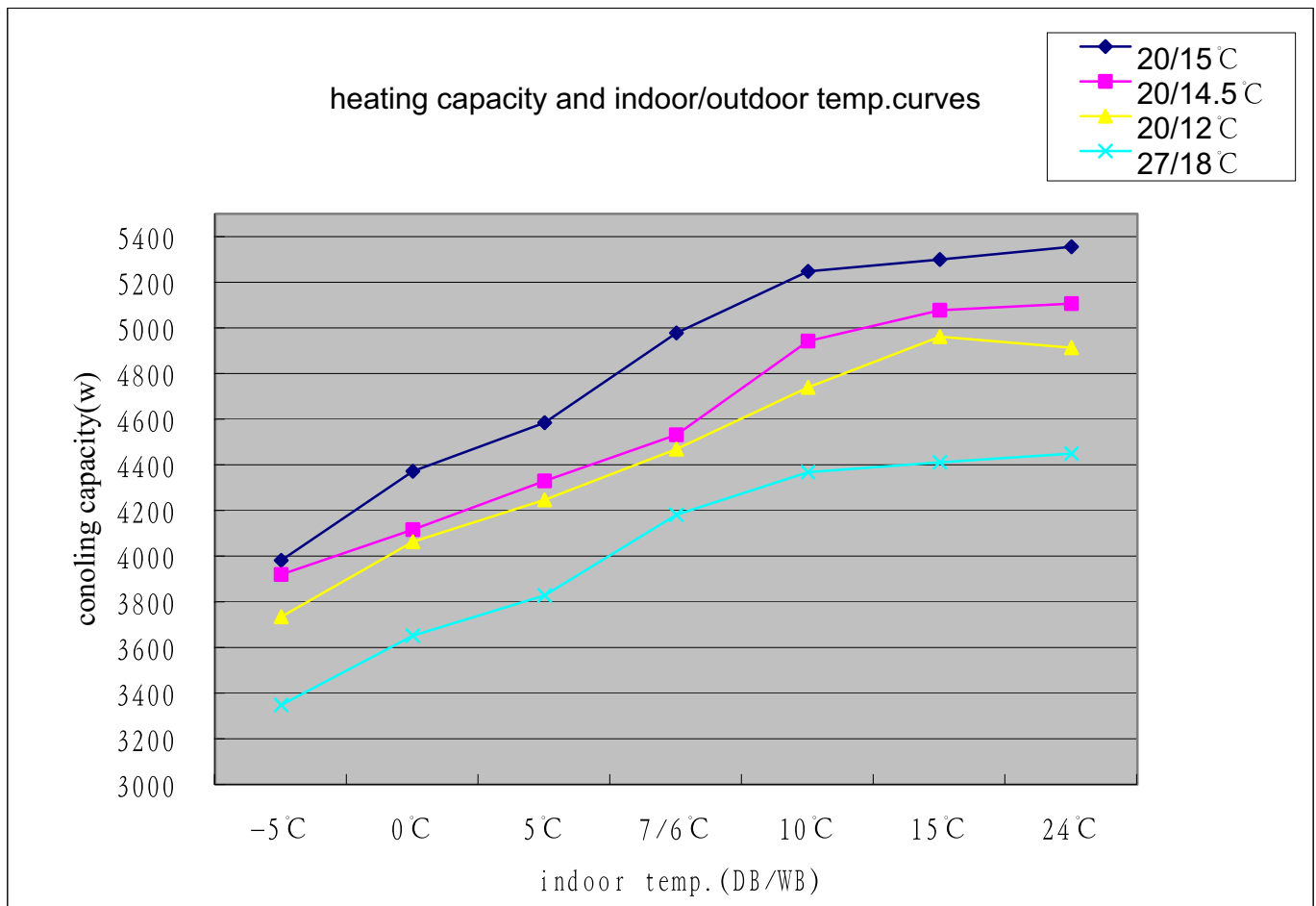

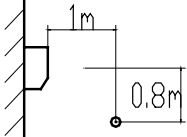

# 10 Sound level

Model	Sound pressure level			Measuring location Location of microphone 	sound power level (cooling/heating)
	220~230V,50Hz				
	Cooling/heating				
	H	L	SL		
HSU-09H03/R(DB)	38/40	25/29	22/26		56/58
HSU-12H03/R(DB)	38/41	36/29	22/26		56/58

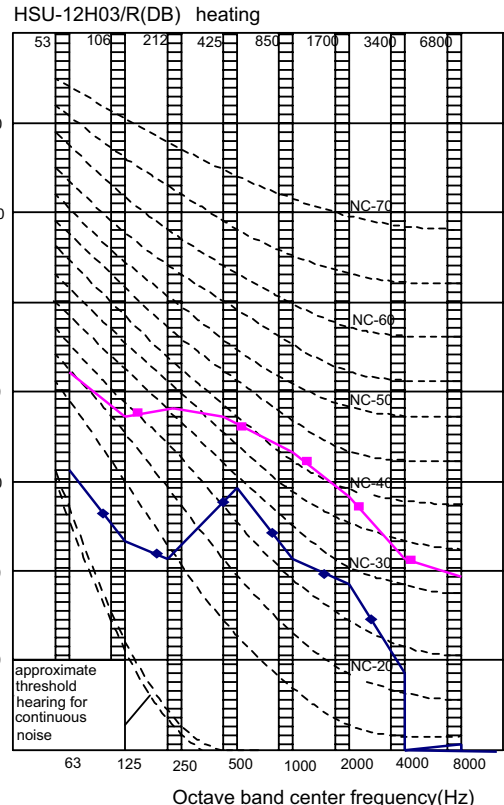
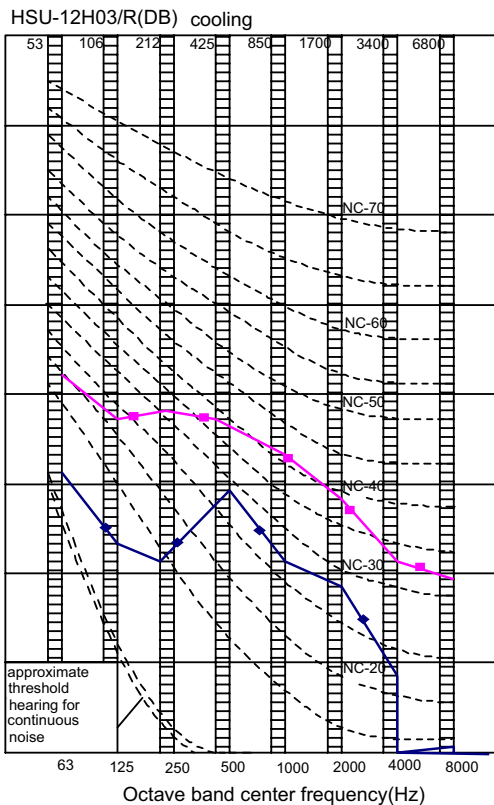
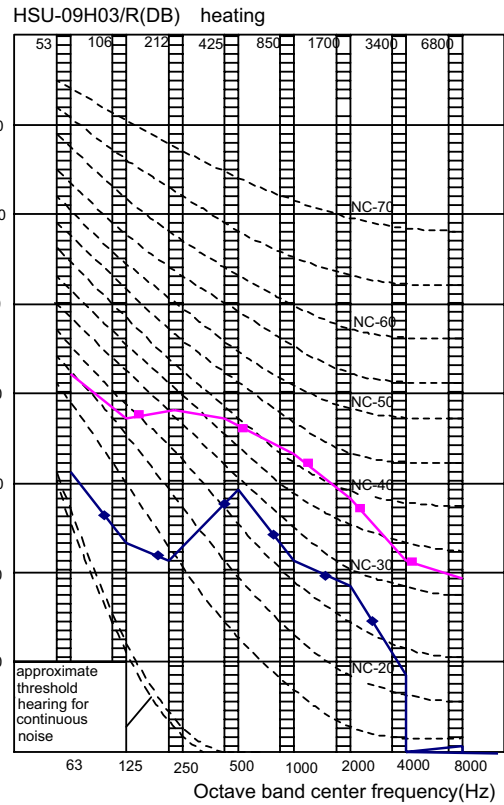
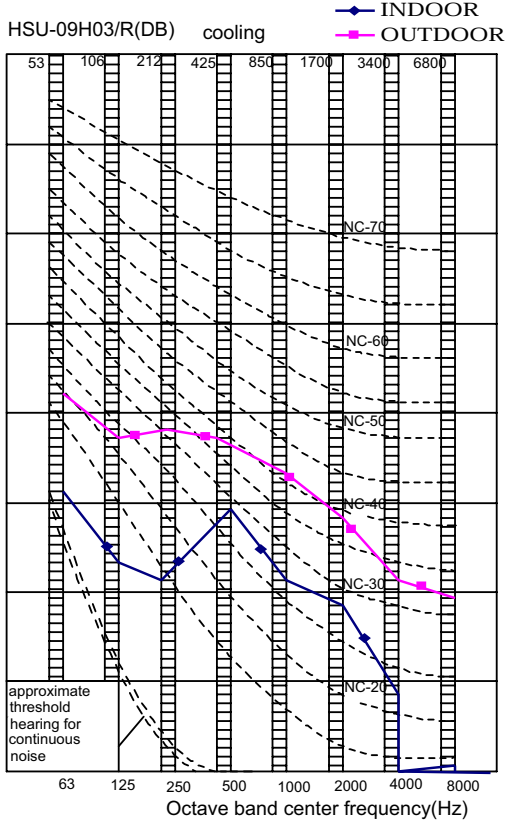

# 11 Accessories

## Standard accessories

Standard name	HSU-09H03/R(DB)	HSU-12H03/R(DB)
Drain hose	1	1
Plastic bag	1	1
screw assembly	1	1
Air purifier	2	2
Battery	2	2
Mounting plate	1	1
Remote controller	1	1
Installation manual	1	1
Operation manual	1	1

# 12 Control systems

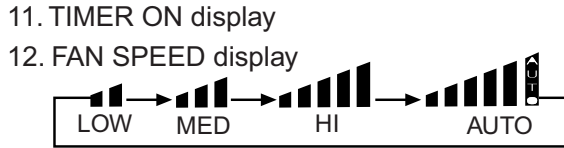
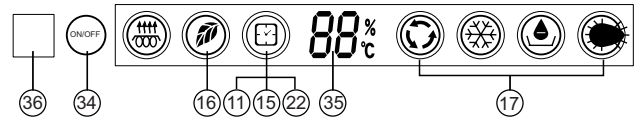
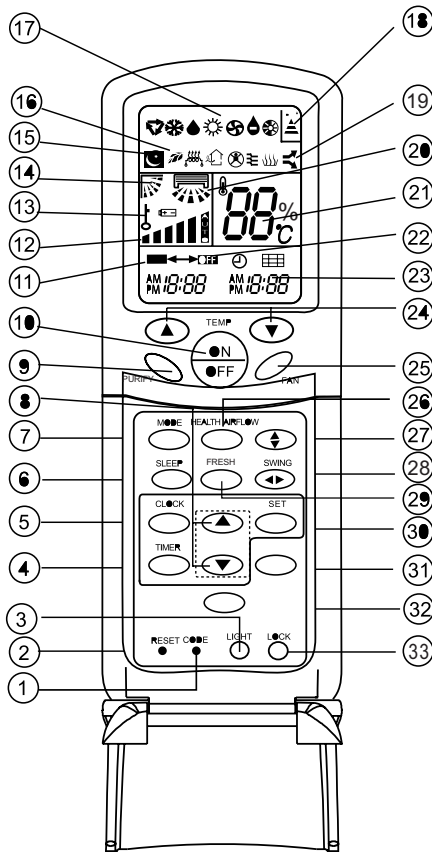

- 11. TIMER ON display
- 12. FAN SPEED display
- 13. LOCK display
- 14. SWING UP/DOWN display
- 15. SLEEP display
- 16. HEALTH display
- 17. Operation mode display

Operation mode	AUTO	COOL	DRY	HEAT	FAN
Remote controller					
Display board					

- 18. Singal sending display
- 19. POWER/SOFT display
- 20. Left/right air flow display
- 21. TEMP display  
Remote controller: to display the TEMP. setting.
- 22. TIMER OFF display
- 23. CLOCK display
- 24. TEMP button  
Used to select your desired temperature.
- 25. FAN button  
Used to select fan speed: LOW, MED, HI, AUTO.
- 26. HEALTH AIRFLOW button  
Used to set the health airflow mode.
- 27. SWING UP/DOWN button  
Used to select up or down air sending direction.
- 28. SWING LEFT/RIGHT button  
Used to select left/right air flow.
- 29. FRESH button  
Use to set fresh air function.
- 30. SET button  
Used to confirm timer and clock settings.
- 31. POWER/SOFT button  
Used to set power/soft function.
- 32. TEMP/HUMIDITY DISPLAY button  
Used for the display panel to choose displaying the actual temperature or the actual humidity at present.
- 33. LOCK  
Used to lock buttons and LCD display. If pressed, the other buttons will be disabled and the lock condition display appears. Press it once again, lock will be canceled and lock condition display disappears.
- 34. ON/OFF button  
Used to set ON/OFF operation and test operation.
- 35. Ambient temp. display  
When receiving the remote control signal, display the set temperature and in the rest time the room temperature is displayed and this room temperature is only for reference.
- 36. Remote signal receiver

- 1. CODE  
Used to select CODE A or B with a press, A or B will be displayed on LCD. Please select A without special explanation.
- 2. RESET  
When the remote controller appears abnormal, use a sharp pointed article to press this button to reset the remote controller normal.
- 3. LIGHT button  
Control the lightening and extinguishing of the indoor LED display board.
- 4. TIMER button  
Used to select TIMER ON, TIMER OFF, TIMER ON-OFF.
- 5. CLOCK button  
Used to set correct time.
- 6. SLEEP button  
Used to select sleep mode.
- 7. MODE button
- 8. HUMIDITY  
Used for adjusting humidity or clock time and timed time.
- 9. Purify button  
Used to set air ionization purify and healthy function.
- 10. ON/OFF button  
Used for unit start and stop.

About temperature/humidity display key:

1. under the constant temperature dehumidification mode, for the first time to enter, then the remote controller displays the set temperature, the display panel displays the actual temperature, press this key, the temperature /humidity won't alternate. After adjusting the set temperature, press this key again, the remote controller will display the set temperature or the set humidity, and the display will display the actual temperature or the actual humidity at the same time.
2. Under the other modes, press this key, the display panel will display the actual humidity at present for a certain time, then the actual humidity will automatically switch back to display temperature. The display of the remote controller won't change.

# 13 Center of gravity

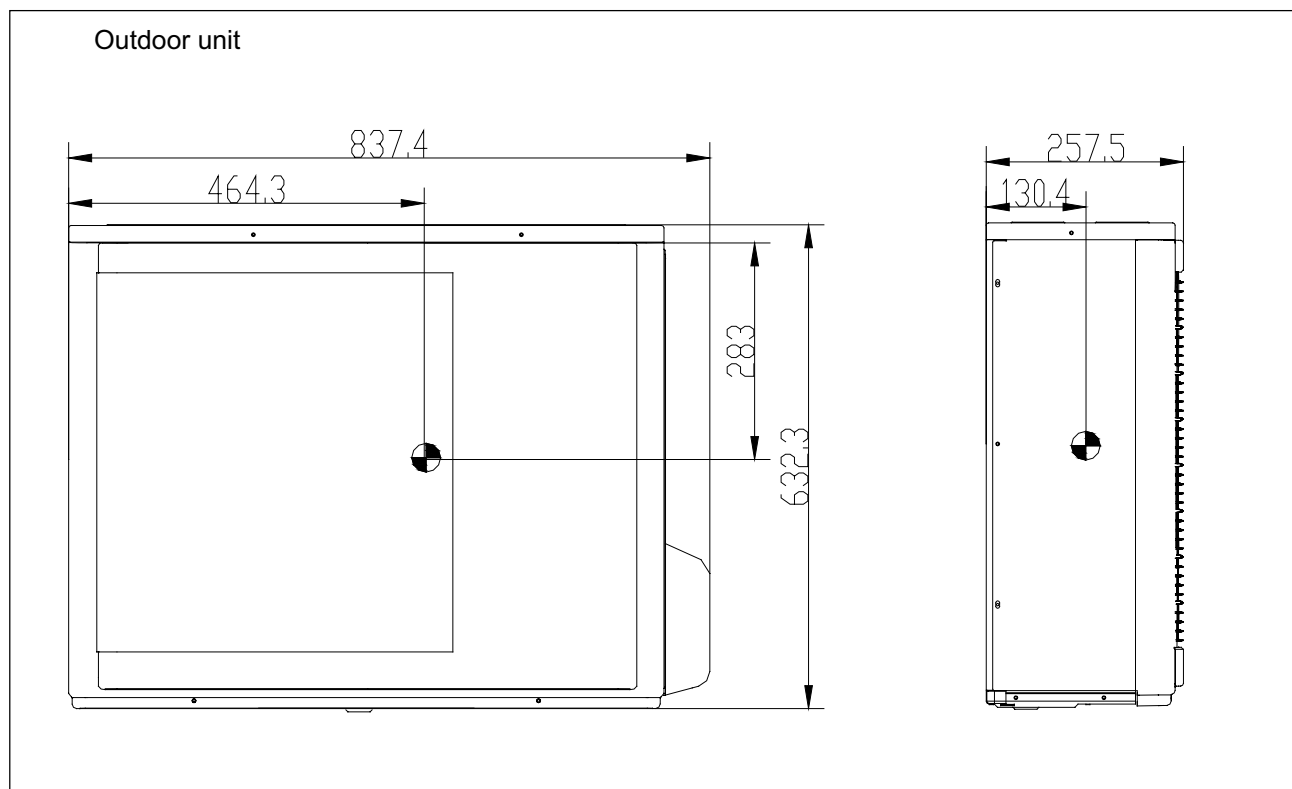
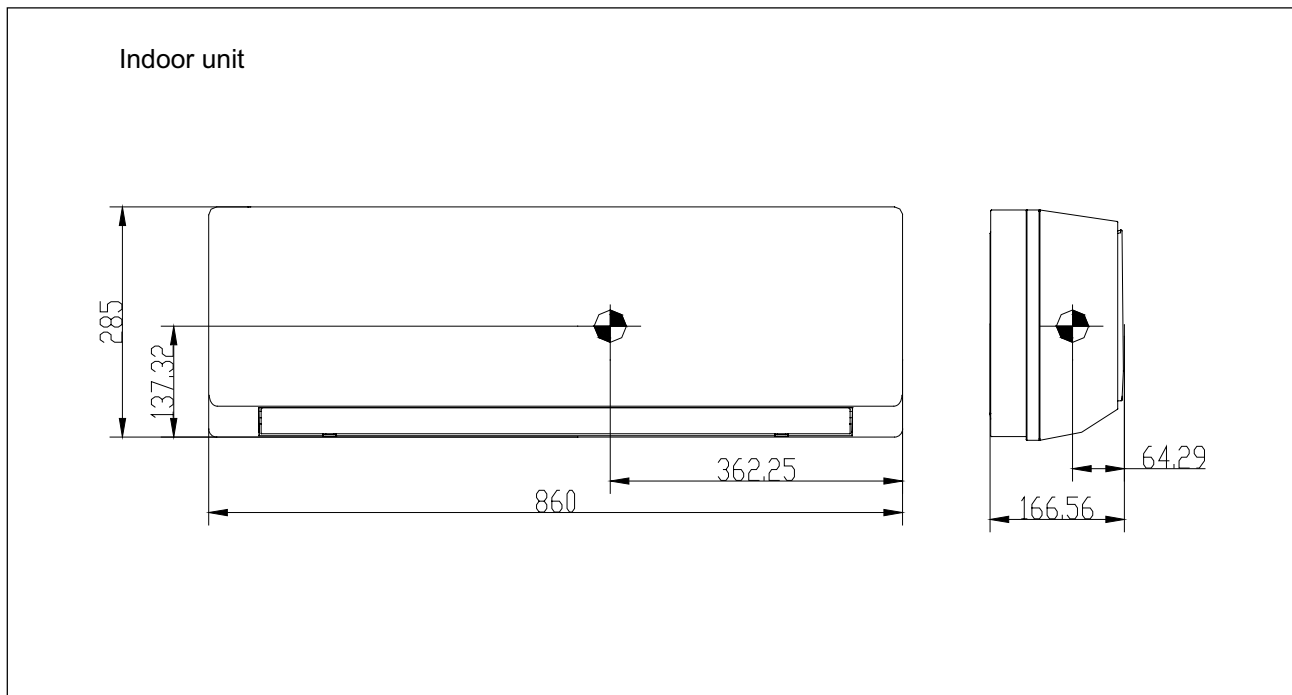

# 14 Installation

## Indoor

- How to attach the indoor unit.  
Hook the claws of the bottom frame to the mounting plate.  
If the claws are difficult to hook ,remove the front panel.
- How to remove the indoor unit.  
Push up the marked area to release the claws .  
If it is difficult to release ,remove the front panel .

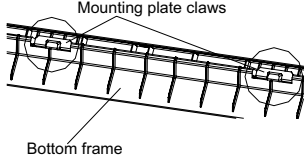

Mounting plate claws

Bottom frame

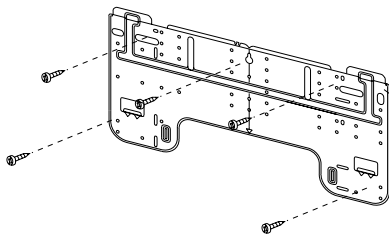

The mounting plate should be installed on a wall which can support the weight of the indoor unit.

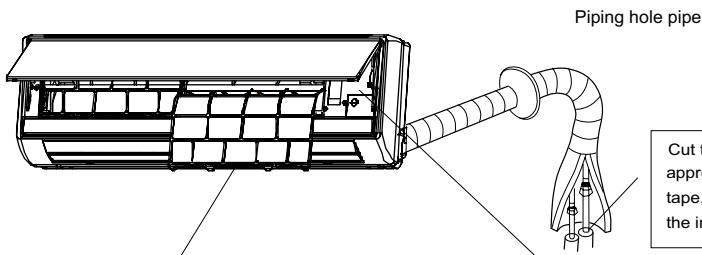

Cut thermal insulation pipe to an appropriate length and wrap it with tape, making sure that no gap is left in the insulation pipe's cut line .

How to remove the air filter  
open the front panel and release the the claws then pull out the air filter.

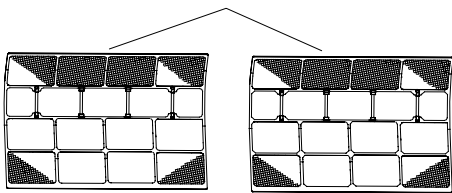

Service lid  
The service lid is an open/close type

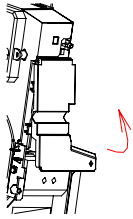

Remove the screws on the service lid.  
Slide the service lid leftward.  
Rotate the service lid upward

### Outdoor

Model	35/40 class
Max.allowable length	20m
Max.allowable height	10m
Additional refrigerant required for refrigerant pipe exceeding 5m in length	16g/m
Gas pipe	O.D. 9.52/12.7
Liquid pipe	O.D. 6.35

\*Be sure to add the proper amount of additional refrigerant. Failure to do so may result in reduced performance.

Arrangement of piping directions

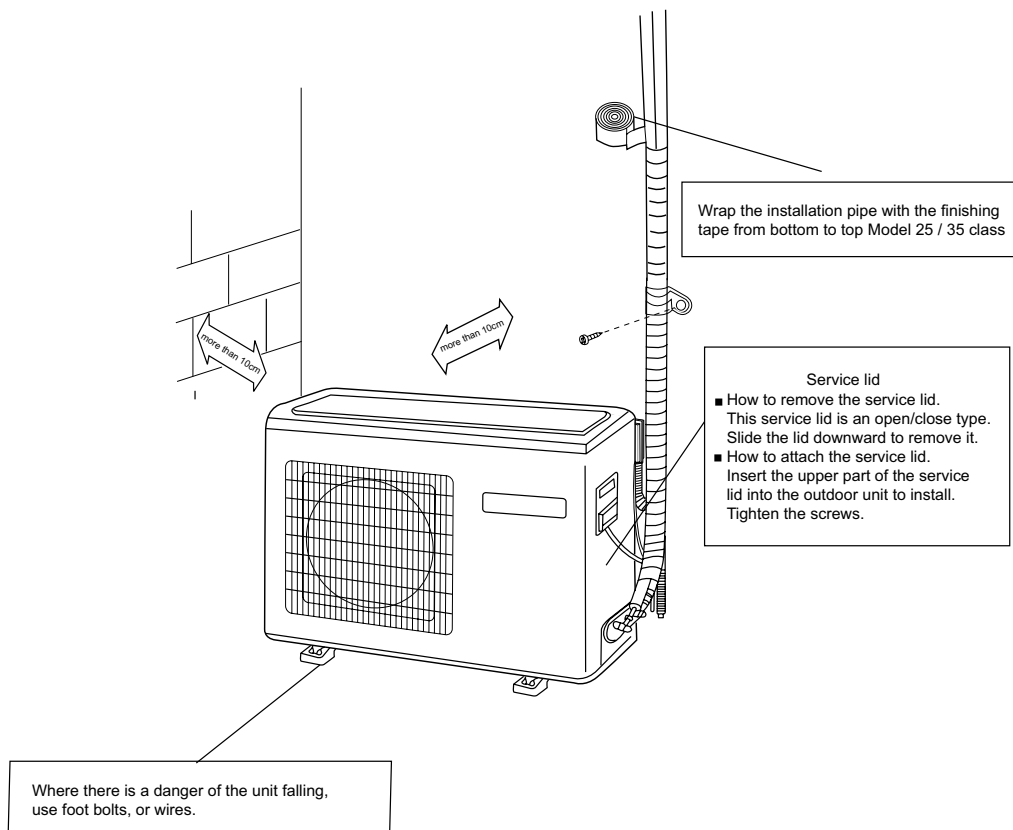
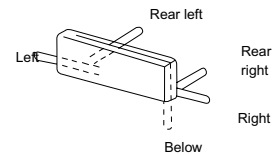

- Fix the unit to concrete or block with bolts( $\varnothing$ 10mm) and nuts firmly and horizontally.
- When fitting the unit to wall surface, roof or rooftop, fix a supporter surely with nails or wires in consideration of earthquake and strong wind. The distance between the indoor unit and the floor should be more than 2m
- If vibration may affect the house, fix the unit by attaching a vibration-proof mat.

# Sincere Forever



## Haier Group

---

Haier Industrial Park, No.1, Haier Road

266101, Qingdao, China

E-mail: [hractech@haier.com](mailto:hractech@haier.com)

Tel: +86 532 87636957

[Http://www.haier.com](http://www.haier.com)

Edited by: Guo Xia

Signed by: Zhang Lizhi

Approved by: Zhu Zhenxue