

Haier

Domestic air conditioner

SERVICE MANUAL



Model

HW-07LN03

HW-09LN03

HW-12LN03

● Feature

- Four side air flowing
- Power Failure Compensation
- Auto Right/Left Swing
- Two cooling/fan/dehumidifying setting
- 24 hours ON/OFF
- Sliding chassis design

1. Product Code Illumination and Series introduction

1). Model code rule description

Model identification:

$$\frac{H}{A} \quad \frac{W}{B} - \frac{\quad}{C} \quad \frac{\quad}{D \quad E} \quad \frac{\quad}{F}$$

A: Abbreviation of Haier

B: Abbreviation of Window

C: Nominal cooling capacity (BTU/h) with the first two numbers based on one thousand unit.

D: Function code

C - Cooling only

H - Heating pump

E - Electric aided heating

E: Developing sequence

F: The type of power supply

Examples:

HW-07/09/12LN03

It represents window air conditioner. Cooling capacity is 7000/9000/12000 BTU/h and the power supply is 220V / 50Hz.

2). Standard situation/conditions

No.	Operating condition	Indoor air state		outdoor air state	
		D.B.	W.B.	D.B.	W.B.
1	Nominal cooling	32	23	43	26
2	Nominal heating	/	/	/	/
3	Nominal electrical Heating	/	/	/	/

3) Brief introduction of window air conditioner series

1. Temperature set knob can adjust the temperature of the air in room
2. Function set knob can control the fan speed as well as the cooling speed.
3. Vent helps you to exhaust any stale unwanted air in the room and draw fresh outside air in the room.

Content

1. Product Code Illumination and Series introduction.....	2
2. Specifications.....	4
3. Main components and accessories' name.....	5
4. Printed Circuit Board Connector Wiring Diagram	7
5. Functions and control.....	11
6. Circuit diagram.....	13
7. Maintenance.....	14
8. Trouble shooting	18
9. Installation and repairing.....	22
10. Compressor performance diagram.....	25

2. Specification

Item		Unit	HW-07LN03	HW-09LN03	HW-12LN03	
Cooling capacity		W	2100	2500	3500	
Heating capacity		W	/	/	/	
Power supply			1, 220, 50	1, 220, 50	1, 220, 50	
Cooling	Power input	W	980	1000	1250	
	Running current	A	4.6	4.8	6.5	
	EER	W/W	2.65	2.5	2.8	
Heating	Power input	W	/	/	/	
	Running current	A	/	/	/	
	COP	W/W	/	/	/	
Sound Level	Indoor side	dB(A)	54/52	54/52	54/52	
	Outdoor side	dB(A)	57/54	57/54	58/56	
Dimension	Net	mm	486x468x352	486x468x352	560x602x380	
	Package	mm	565x568x447	565x568x447	595x685x460	
Weight	Net	Kg	27	27	33	
	Gross	Kg	32	32	38	
Compressor	Manufacture		RUICHI	RUICHI	RUICHI	
	Type		44R193AE-AJSC	44R233CF-AJSC	48R313AK-5JSE	
	Oil Charge	ml	260	260	260	
Pressure	Heating side	MPa	2.65	2.65	2.65	
	Cooling side	MPa	0.65	0.65	0.65	
Refrigerant	Model		R22	R22	R22	
	Charge	g	410	380	385	
Fan	Type	Indoor unit		Centrifugal fan	Centrifugal fan	Centrifugal fan
		Outdoor unit		Axial fan	Axial fan	Axial fan
	Fan Speed	High	r/min	1000	1000	890
		Low	r/min	920	920	820
Air volume		m ³	360	360	450	
Moisture removal		10 ⁻³ m ³ /h	1.2	1.2	1.2	
Exchanging pipe type/diameter		mm	/	/	/	
Fin material			/	/	/	

3. Main components and accessories' name

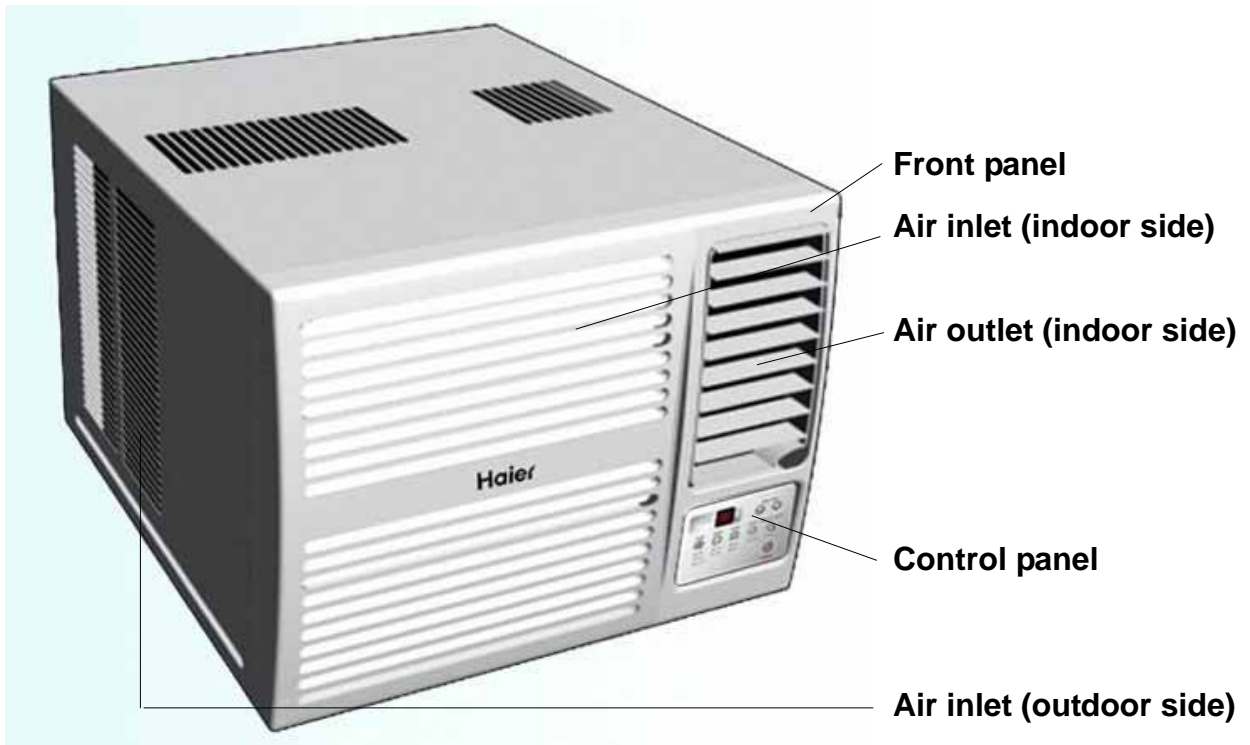

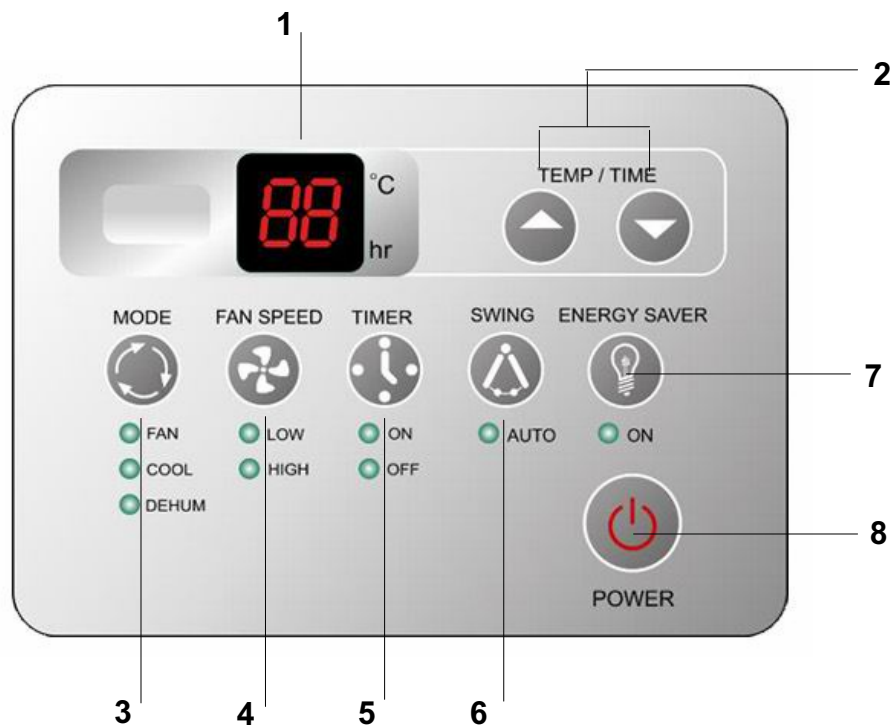

1. TEMP. / TIME display

2. TEMP./TIME set

Used to set TIME or TEMP. setting.

3. MODE

Used to select operation mode: FAN, COOL, DEHUM

4. FAN SPEED

Used to select desired fan speed:LOW or HIGH

5. TIMER

Used for TIMER start or stop.

6. SWING

Used to activate the vertical louver.This will give you an even airflow throughout the room.

7. ENERGY SAVER

This will not only save your electrical and energy costs but also shuts off the unnecessary noise of the fan motor running.

8. POWER

Press it to start unit and press it again to stop.

4. Printed Circuit Board Connector Wiring Diagram

Connectors Indoor PCB

- 1)CN2 connector for room temp. sensor.
- 2)CN3 connector for receiver display.
- 3)CN8 connector for high fan.
- 4)CN10 connector for low fan.
- 5)CN11 connector for fan motor.
- 6)CN12 connector for louver motor.
- 7)CN13 connector for louver motor.
- 8)CN14 connector for power line.

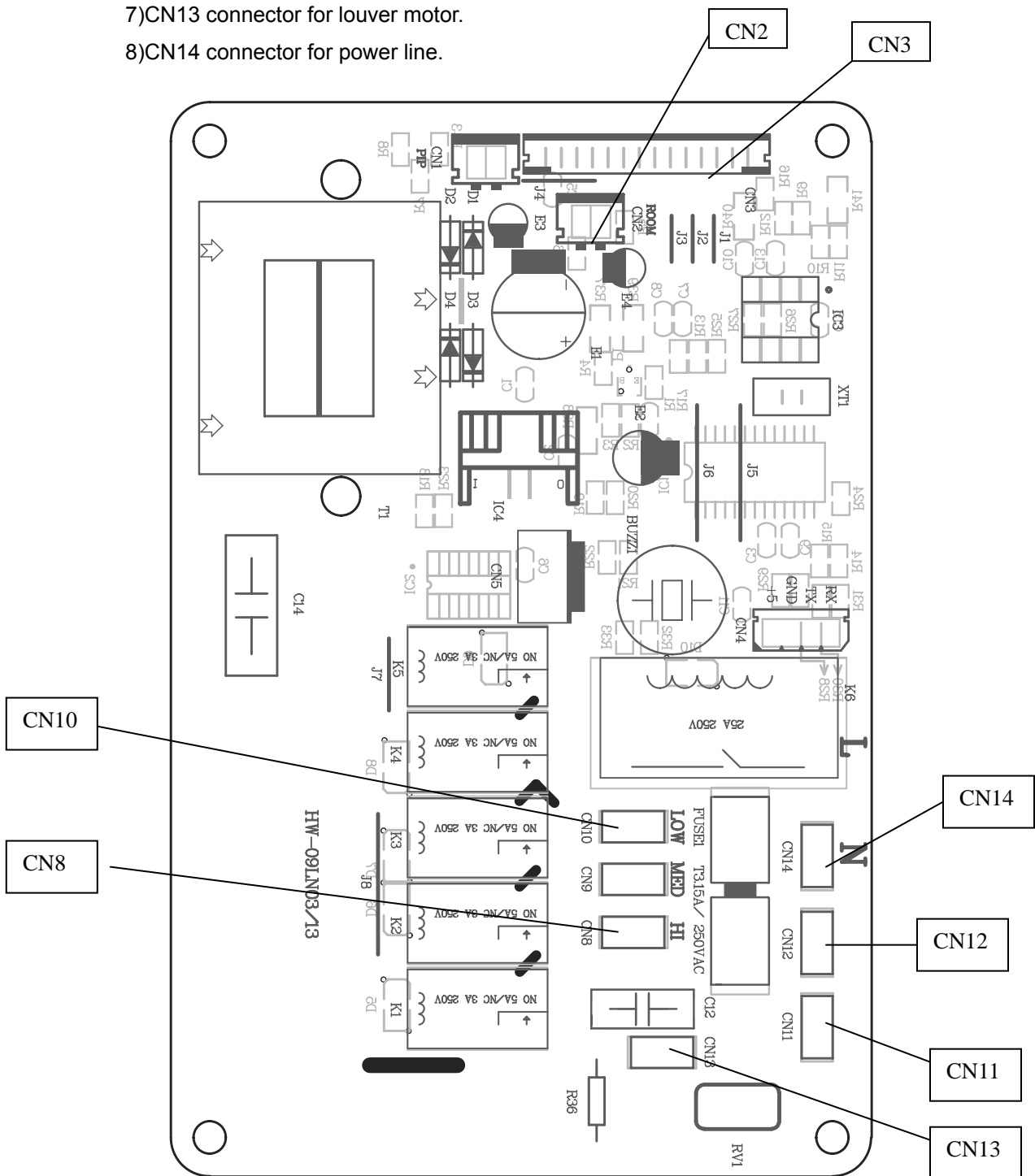

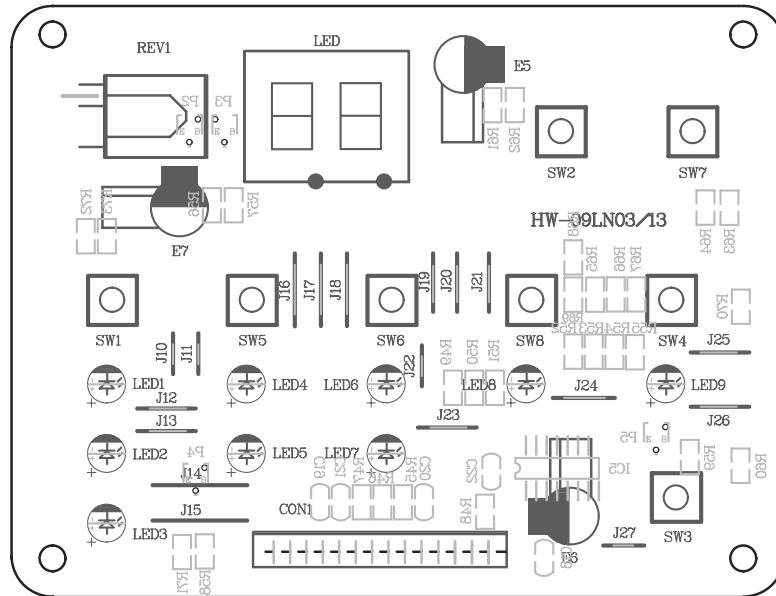

receiver display

5. Functions and control

5.1 Introduction to electrical control functions

Including brief introduction to air conditioners of series models and electric control function.

5.1.1 Cooling run mode:

temperature control range :16 —30

temperature control precision: ± 1

compressor can't be controlled by temperature sensor within 2 minutes after it starts.

control character: when $T_r \geq T_s$, outlet air from compressor is on and indoor fan motor run at fixed wind speed ; When $T_s - 2 \leq T_r < T_s$, outlet air from compressor keep the former state ; When $T_r \leq T_s - 2$, outlet air from compressor is off.

Manual operation: When unit is on, the wind speed can be set to high, low as required (execute instruction 2 seconds later after receiving remote signal)

Compressor control : The compressor can't be controlled by temperature sensor within 2 minutes after start up and can be only restarted at least 3 minutes later after shutdown. There is no 3-minute protection with power on for the first time (over 3 minutes with power off). The compressor must stands by for 3 minutes before it is restarted after shut down.

There is no 2-minute limit when changing the temperature setting or shutting down the machine through the remote controller, and the machine can be shut down immediately.

Timer on, Timer off control are available.

Energy saver : When set the function, fan and swing will shutdown after compressor off 3 minutes later. This will not only save your electrical and energy costs but also shuts off the unnecessary noise of the fan motor running.

5.1.2 Dehumidifying mode :

Temperature control range : 16 —30

Control character :

T_r : temperature inside the room ; T_s : the set temperature.

When $Tr > Ts + 2$, the compressor run continuously with indoor fan motor running in accordance with the wind speed setting.

When $Ts - 1 \leq Tr \leq Ts + 2$, the compressor will cycle for 10 minutes on and 6 minutes off,

When $Tr < Ts - 1$, the compressor will shut off, and the fan motor runs at low speed.

Timer on, Timer off control are available.

5.1.3 Fan mode :

The temperature set unavailable.

Fan motor running in accordance with the speed setting.

The compressor shut off.

Timer on, Timer off control are available.

5.2 Control function:

5.2.1 Self-checking function: All indicators come on and the nixie tube displays no other than "8" at the first power-on. The unit turns to the waiting state 3 seconds later.

5.2.2 Timer function:

You can set 24-hour timer on or timer off as required, and the minum time unit is 1 hour. After setting, the indicator of indoor unit is on , and it is off when timer setting is completed. There are several timer mode as follows.

Timer on: The LED of "timer on" lights up, and unit behaves with halt status. Timer on is completed, and then unit starts running with the LED of "timer on" off. The unit starts with the the last setting receiving timer signals, and sleep setting is not allowed.

Timer off: Unit starts, timer indicator lights up; When reaching time setting, the indicator goes out, unit enters shut down mode, and sleep function can be set. If timer off and sleep are set synchronously, the one which time is short run first. Executing shutdown instruction clear timer and sleep function.

Timer on and timer off can be set only one mode at the same time.

5.2.3 Abnormity Diagnose

1. Sensor diagnose: 2 seconds after the sensors open circuit or short circuit, the unit will turn off automatically and the LED will show E0 until the sensors resume.

2. Keystroke circuit error diagnose: When power on for the first time, the PCB will check the keystroke circuit, if the sampling value is different with the theory value, the LED will show E1, which means failed keystroke circuit. The keyboard is locked and so invalid, but the remote control is working normally.

5.2.4 Power failure resume(please set and apply as necessary)

If sudden power failure occurs, the unit will resume original operation when power is supplied again.

Note:

When sudden power failure happens during unit operation in power failure resume mode, if the air conditioner is not desired for use in a long period, please shut off the power supply in case that the unit automatically resume operation when power is re-supplied, or press POWER to turn off the unit when power resumes.

5.3 Value of Thermistor room temperature sensor

R25 =5KΩ±1%

B25 /50 =3450K±1%

Temp.()	Max.(KΩ)	Normal(KΩ)	Min.(KΩ)	Tolerance()	
-20	38.5398	37.3992	36.2887	-1.78	1.62
-19	36.5922	35.5274	34.4900	-1.76	1.60
-18	34.7549	33.7607	32.7916	-1.74	1.59
-17	33.0211	32.0927	31.1872	-1.72	1.57
-16	31.3843	30.5172	29.6710	-1.70	1.56
-15	29.8385	29.0286	28.2377	-1.68	1.54
-14	28.3782	27.6216	26.8824	-1.66	1.53
-13	26.9981	26.2913	25.6003	-1.64	1.51
-12	25.6934	25.0330	24.3870	-1.62	1.49
-11	24.4595	23.8424	23.2384	-1.60	1.48
-10	23.2922	22.7155	22.1508	-1.58	1.46
-9	22.1875	21.6486	21.1205	-1.56	1.44
-8	21.1417	20.6380	20.1443	-1.53	1.43
-7	20.1513	19.6806	19.2189	-1.51	1.41
-6	19.2131	18.7732	18.3414	-1.49	1.39
-5	18.3241	17.9129	17.5092	-1.47	1.38
-4	17.4813	17.0970	16.7195	-1.45	1.36
-3	16.6822	16.3230	15.9700	-1.43	1.34
-2	15.9242	15.5886	15.2585	-1.40	1.32
-1	15.2050	14.8913	14.5827	-1.38	1.30
0	14.5224	14.2293	13.9408	-1.36	1.29
1	13.8757	13.6017	13.3320	-1.34	1.27
2	13.2617	13.0057	12.7534	-1.31	1.25
3	12.6786	12.4393	12.2035	-1.29	1.23
4	12.1247	11.9011	11.6806	-1.27	1.21
5	11.5983	11.3894	11.1833	-1.24	1.19
6	11.0979	10.9028	10.7102	-1.22	1.17
7	10.6221	10.4399	10.2599	-1.20	1.15
8	10.1696	9.9995	9.8313	-1.17	1.13
9	9.7390	9.5802	9.4231	-1.15	1.11
10	9.3292	9.1810	9.0343	-1.13	1.09
11	8.9391	8.8008	8.6638	-1.10	1.07
12	8.5676	8.4385	8.3107	-1.08	1.04
13	8.2137	8.0934	7.9740	-1.05	1.02

14	7.8765	7.7643	7.6530	-1.03	1.00
15	7.5551	7.4506	7.3468	-1.00	0.98
16	7.2487	7.1513	7.0546	-0.98	0.96
17	6.9565	6.8658	6.7757	-0.95	0.94
18	6.6778	6.5934	6.5095	-0.93	0.91
19	6.4118	6.3333	6.2552	-0.90	0.89
20	6.1579	6.0850	6.0124	-0.88	0.87
21	5.9156	5.8479	5.7803	-0.85	0.84
22	5.6841	5.6213	5.5586	-0.83	0.82
23	5.4631	5.4048	5.3466	-0.80	0.80
24	5.2519	5.1978	5.1439	-0.78	0.77
25	5.0500	5.0000	4.9500	-0.78	0.77
26	4.8608	4.8108	4.7609	-0.78	0.78
27	4.6797	4.6298	4.5800	-0.82	0.81
28	4.5064	4.4566	4.4070	-0.86	0.85
29	4.3404	4.2909	4.2415	-0.89	0.88
30	4.1815	4.1323	4.0832	-0.93	0.92
31	4.0293	3.9804	3.9316	-0.97	0.95
32	3.8835	3.8349	3.7865	-1.00	0.99
33	3.7438	3.6955	3.6475	-1.04	1.02
34	3.6098	3.5620	3.5144	-1.08	1.06
35	3.4814	3.4340	3.3869	-1.12	1.09
36	3.3582	3.3113	3.2647	-1.16	1.13
37	3.2401	3.1937	3.1476	-1.20	1.16
38	3.1267	3.0809	3.0353	-1.23	1.20
39	3.0180	2.9727	2.9276	-1.27	1.24
40	2.9136	2.8688	2.8244	-1.31	1.27
41	2.8134	2.7692	2.7253	-1.35	1.31
42	2.7171	2.6735	2.6302	-1.39	1.34
43	2.6247	2.5816	2.5389	-1.43	1.38
44	2.5359	2.4934	2.4513	-1.48	1.42
45	2.4505	2.4087	2.3672	-1.52	1.45
46	2.3685	2.3273	2.2864	-1.56	1.49
47	2.2897	2.2491	2.2088	-1.60	1.53
48	2.2139	2.1739	2.1342	-1.64	1.57
49	2.1410	2.1016	2.0626	-1.68	1.60
50	2.0709	2.0321	1.9937	-1.73	1.64
51	2.0038	1.9656	1.9278	-1.77	1.68
52	1.9391	1.9015	1.8644	-1.81	1.72
53	1.8769	1.8399	1.8033	-1.85	1.76
54	1.8168	1.7804	1.7445	-1.90	1.79

55	1.7590	1.7232	1.6879	-1.94	1.83
56	1.7032	1.6680	1.6333	-1.99	1.87
57	1.6495	1.6149	1.5808	-2.03	1.91
58	1.5977	1.5636	1.5301	-2.07	1.95
59	1.5477	1.5142	1.4813	-2.12	1.99
60	1.4995	1.4666	1.4343	-2.16	2.03
61	1.4530	1.4206	1.3889	-2.21	2.07
62	1.4081	1.3763	1.3452	-2.25	2.11
63	1.3648	1.3336	1.3030	-2.30	2.15
64	1.3230	1.2923	1.2623	-2.35	2.19
65	1.2827	1.2526	1.2231	-2.39	2.23
66	1.2438	1.2142	1.1852	-2.44	2.27
67	1.2062	1.1771	1.1487	-2.49	2.31
68	1.1699	1.1413	1.1134	-2.53	2.35
69	1.1348	1.1068	1.0794	-2.58	2.39
70	1.1010	1.0734	1.0465	-2.63	2.43
71	1.0682	1.0412	1.0148	-2.68	2.48
72	1.0366	1.0100	0.9842	-2.73	2.52
73	1.0061	0.9800	0.9546	-2.77	2.56
74	0.9765	0.9509	0.9260	-2.82	2.60
75	0.9480	0.9228	0.8984	-2.87	2.64
76	0.9204	0.8957	0.8717	-2.92	2.68
77	0.8937	0.8695	0.8460	-2.97	2.73
78	0.8679	0.8441	0.8211	-3.02	2.77
79	0.8429	0.8196	0.7970	-3.07	2.81
80	0.8188	0.7959	0.7737	-3.12	2.86

6. CIRCUIT DIAGRAM

Circuit diagram 1

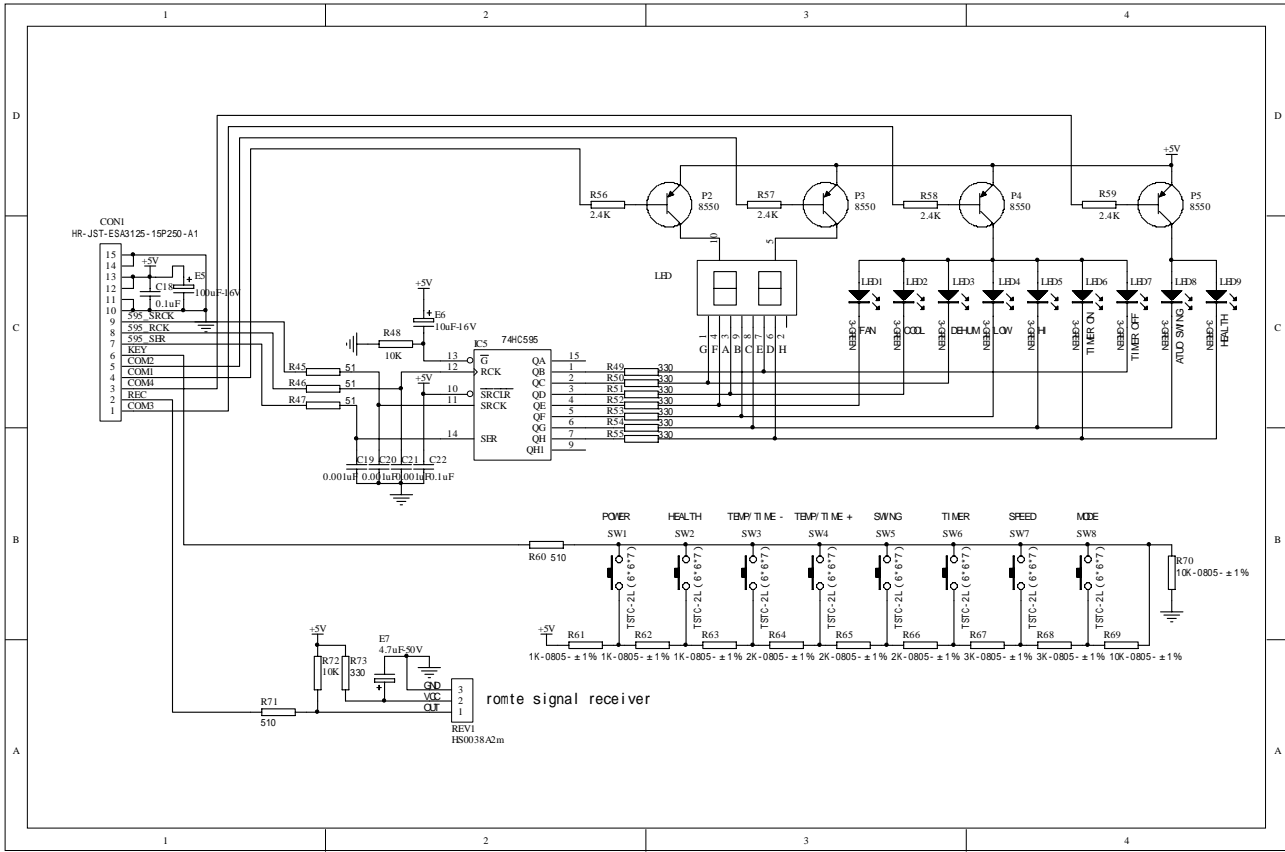

Circuit diagram 2

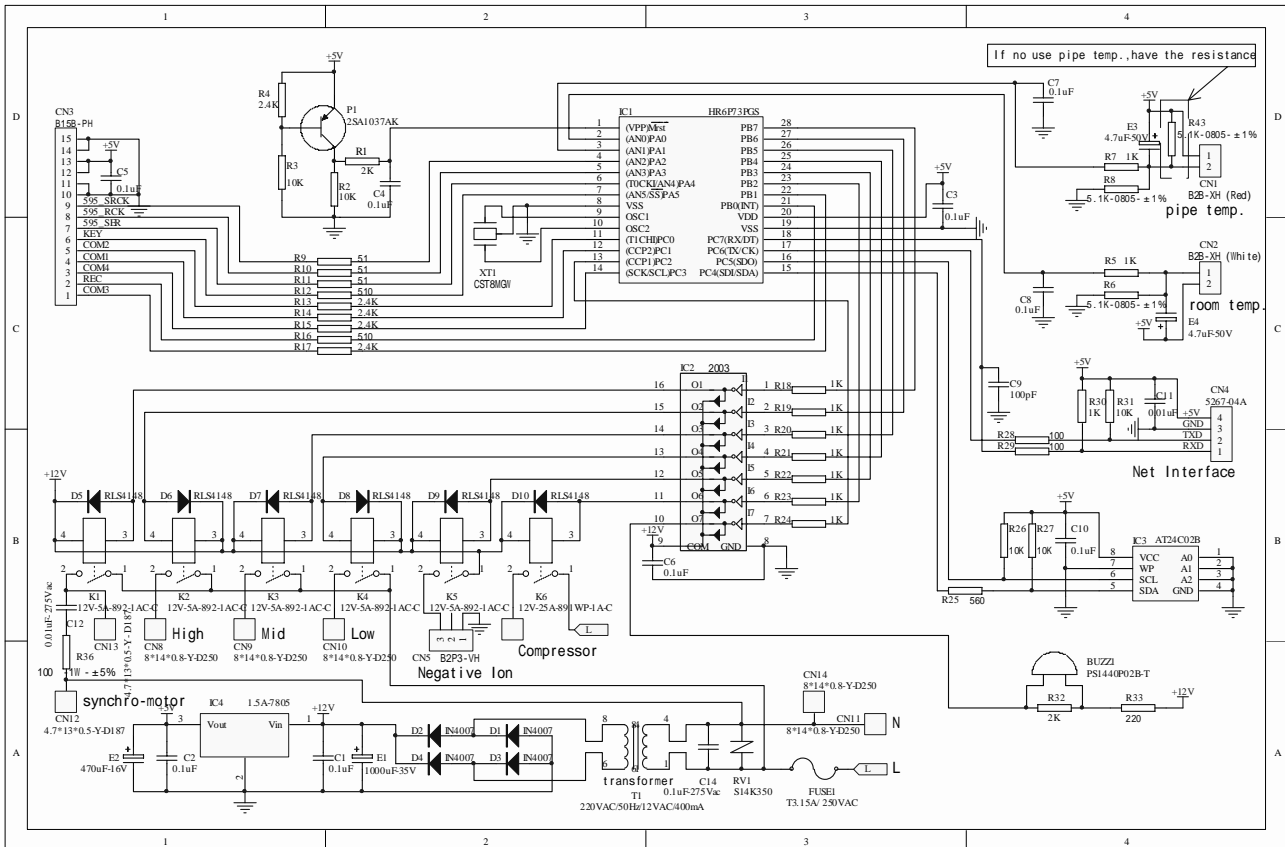

7.Maintenance

NOTE: Always unplug the air conditioner before servicing or moving it.

When dirt accumulates on air filter, air circulation will be blocked, which causes poor cooling. It is advisable to clean air filter every two weeks for longer operation.

Removal of air filter

1. Loosen the air inlet by pushing "PUSH" at both edges as shown.
2. Open the air inlet.
3. Remove the air filter.

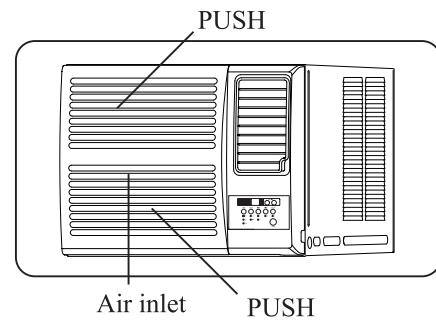

Air filter cleaning

1. Gently flap the dirt off the air filter.
2. Carefully wash air filter in warm water (below 40°C). To obtain better cleaning effect, soap water or neutral detergent may be used.
3. Flush air filter carefully with clean water after removing dirt. Let it dry completely.

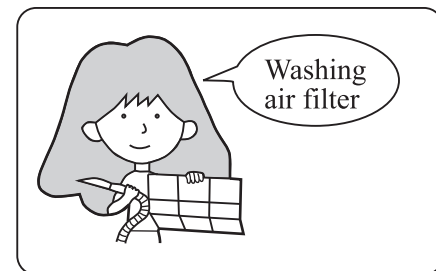

Installation of filter

1. Replacing the air filter.
2. Push the air inlet marked with "PUSH" until you hear a click.

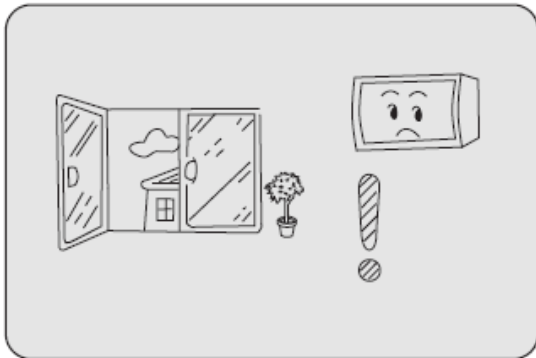

Avoid opening doors and windows unless necessary.



Don't be exposed to cold air for a long time.

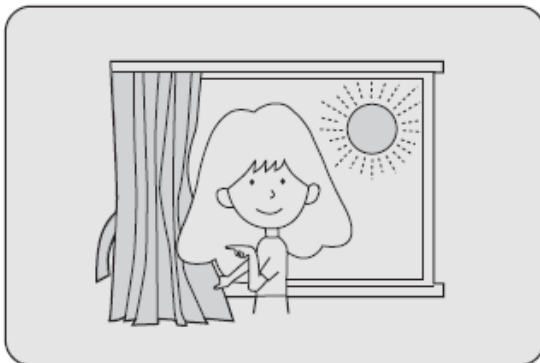

**Use curtain or blind
Direct sunlight may reduce cooling effect, always use window curtain.**

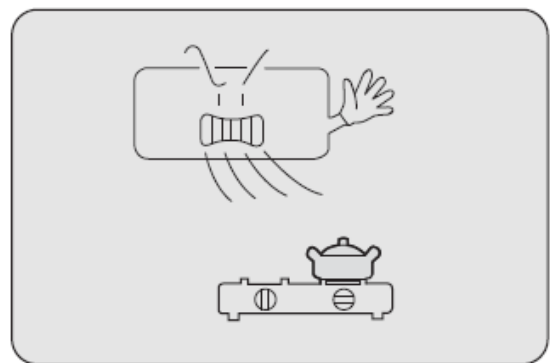

Keep heat source away from air conditioner.

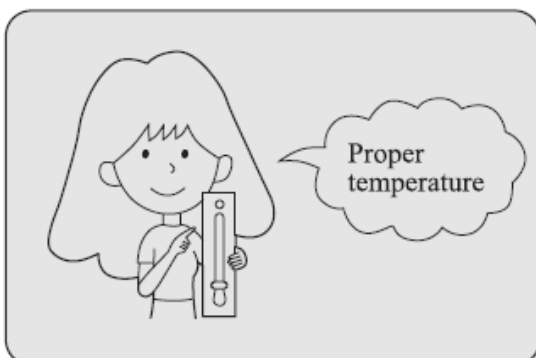

Set temp. a little bit higher before going to bed.



After unit stops, don't restart it until 3 minutes have elapsed.

Disposal of the condensed water

Generally there are two methods available on disposal of the condensed water:

1. Block the bottom plate hole of the conditioner with rubber lid, install drain elbows on the back hole and let the condensing water flow from the back hole of the conditioner. (See Fig.1)

In this method, the accumulated condensed water in the bottom plate is hit by the fan onto the heat exchanger, and evaporated and blown out from the machine. It can cool the heat exchanger radiator more quickly, and improve the energy efficiency of the conditioner. But the hitting noise by the fan at the outdoor side is relatively large.

2. Block the back hole of the conditioner with rubber lid and install drain elbow to the bottom hole, which can make the condensed water flow out from the bottom plate. (See Fig.2)



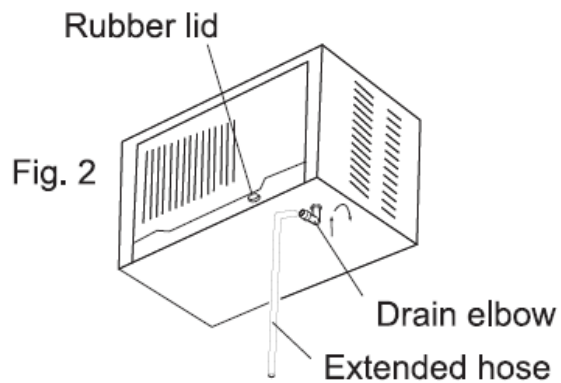
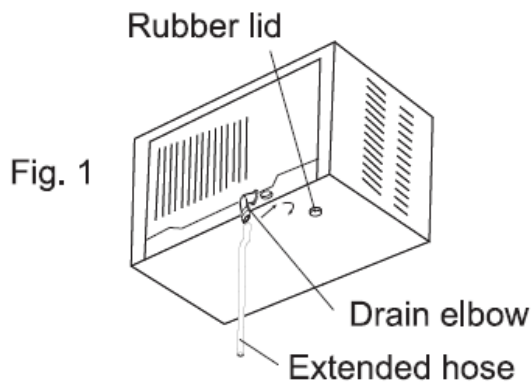

This method can reduce the hitting noise by the fan at the outdoor side.

If necessary the above two methods can both have extra pipe added on the drain elbow (available on the market).



Note:

When install drain elbow, adjust the direction of the drain elbow to make it be in line with the hole in the rear of unit; Insert the drain tube into hole and twist 90°.

<p>Before cleaning please pull of the power plug.</p> 	<p>Do not clean the machine with following material in order to decrease pollution: petrol, detergent.</p> 
<p>Do not pour water on the machine to prevent electric shock or mechanical trouble.</p> 	<p>Hot water above 40 may cause discoloration of the shell or deformation.</p> 

Cleaning of the shell and remote controller

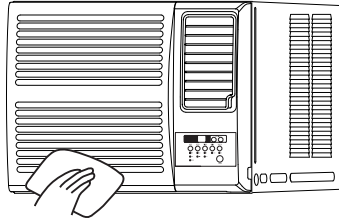

Wipe the shell with soft cloth. If it is very dirty, please use water with diluted neutral detergent. In wiping, first twist out the water in the cloth.

Wipe out the detergent on the machine shell completely.

Adjusting of the air direction

Airflow Direction Vane

- The Vertical Airflow Direction Vane is manually controlled by positioning the vane to discharge the air upward, downward or straight out.
- The horizontal air direction is adjusted by setting the AUTO SWING ON .

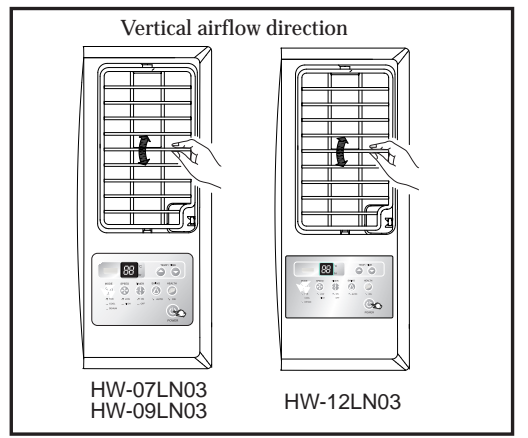

Note:

- It is advisable not to keep vertical flap at downward position for a long time in COOL or FAN mode, otherwise , condensate water might occur.
- Don't move the horizontal flap with hand in order to avoid the vertical flap abnormal, using the remote controller to adjust the move of vertical flap.

8. Trouble shooting

Before sending to repair, please first check the following:

Phenomenon	Reason
Switch on the machine but it does not work immediately.	If the machine is started after stop, it will need about 3 minutes to re-start so as to prevent fuse from break.
Switch on the machine but it does not work.	<ol style="list-style-type: none"> 1. Is the power on? 2. Is the fuse broken? 3. Is plug firmly inserted?
The cooling effect is not good.	<ol style="list-style-type: none"> 1. Is the air inlet or outlet entrance blocked? 2. Is there direct sunlight in cooling? 3. Are the doors and windows closed? 4. In cooling are there too many heating sources? 5. Is the filter too dirty (generally it should be washed every two weeks)?

Error Codes and Description

	Code indication	Description	Reference Page
	indoor		
Indoor Malfunction	E0	Room temperature sensor failure	
	E1	Keystroke circuit error diagnose	

Trouble Shooting

E0: Room temperature sensor failure CN2

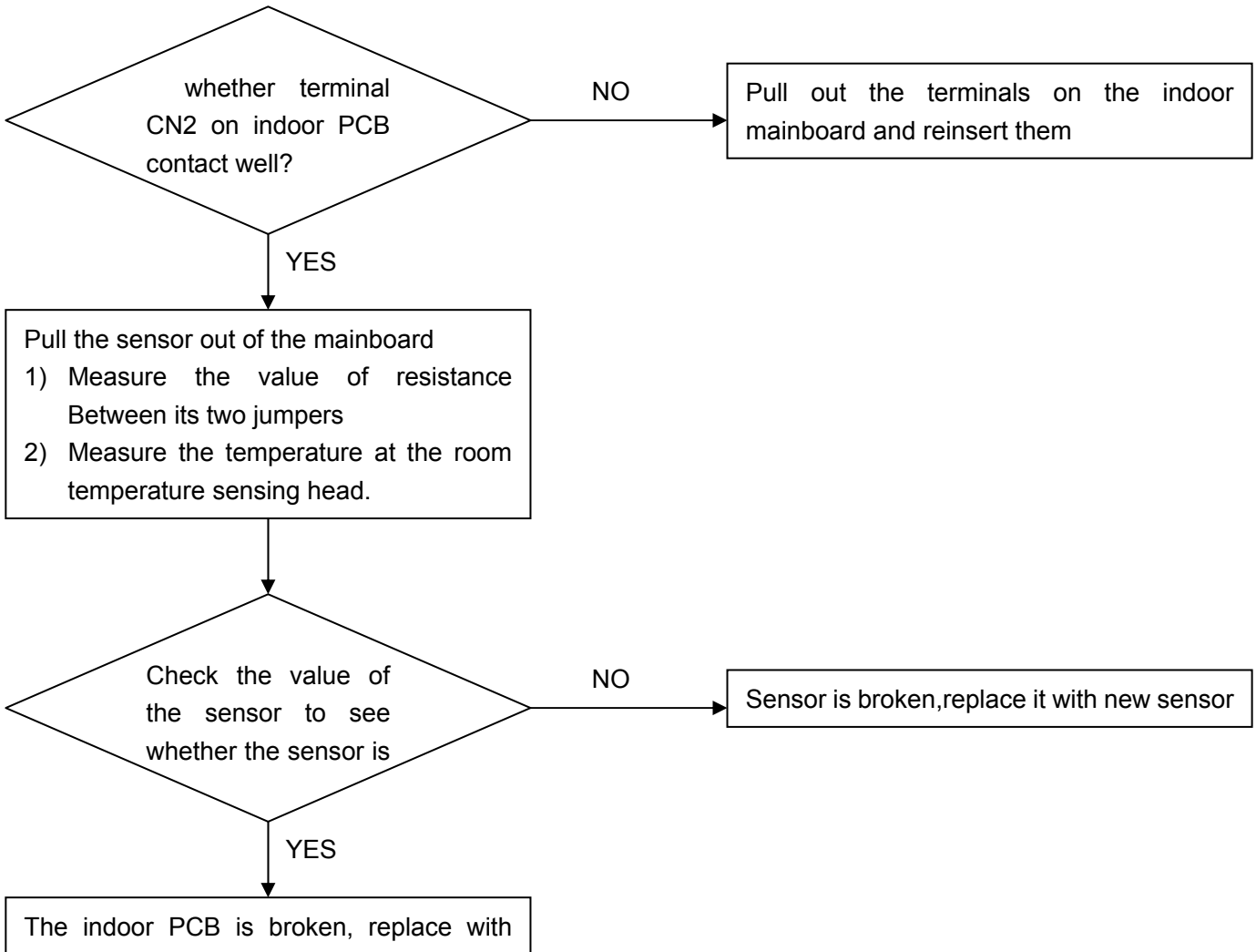

E1: Keystroke circuit error diagnose

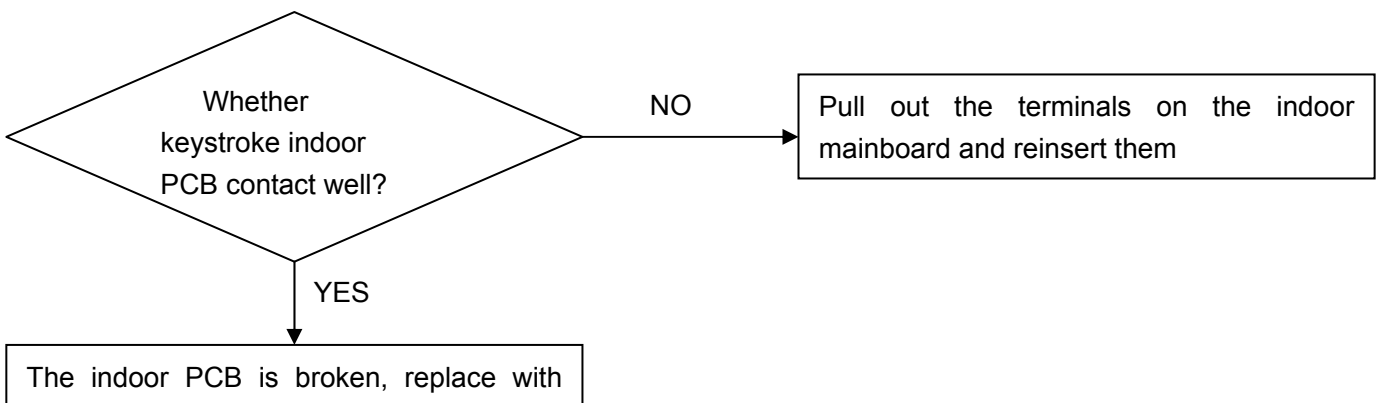

10. System flow chart

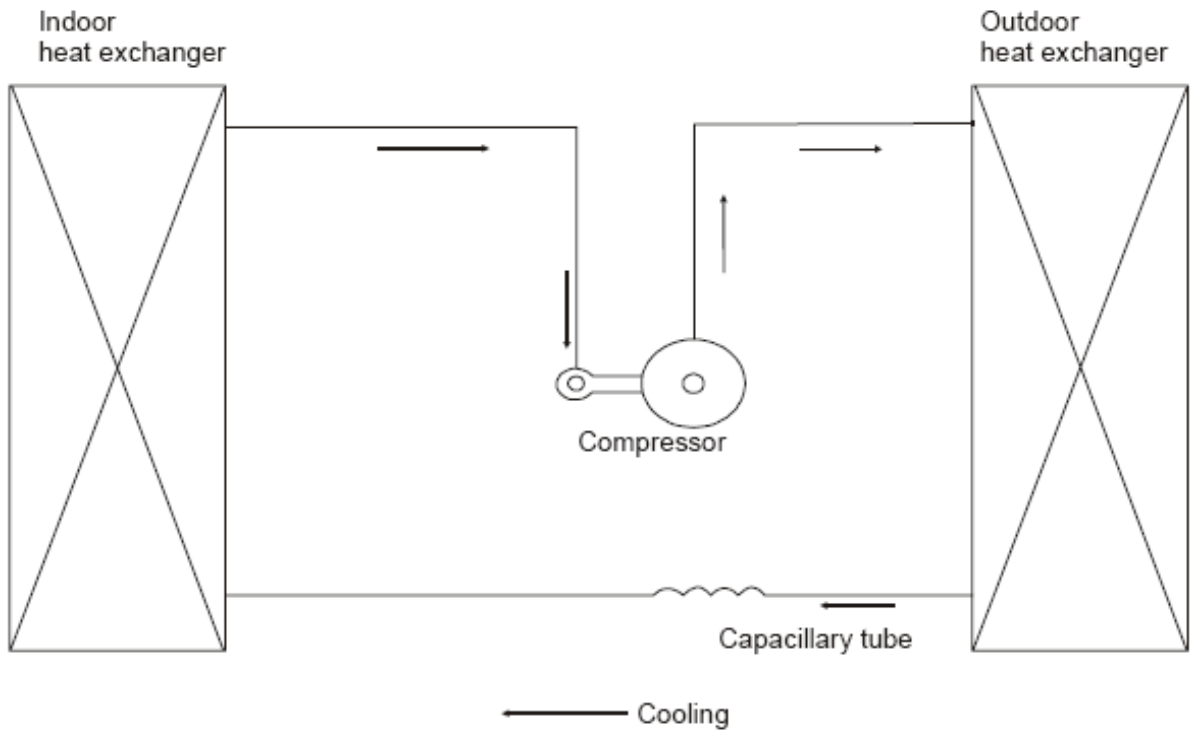

7. Wiring diagram

WIRING DIAGRAM

0010511621

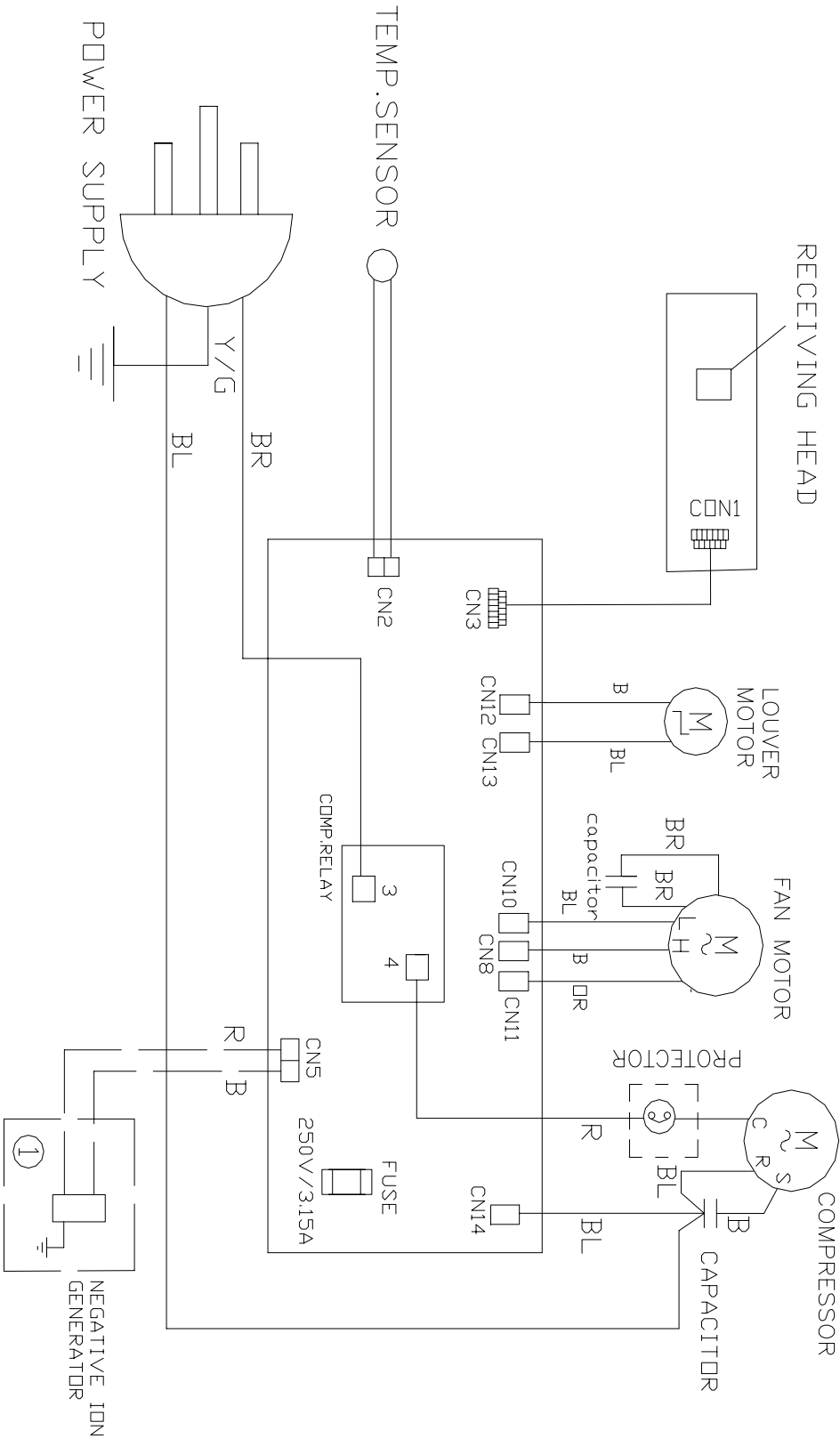

R:RED DR:ORANGE
 B:BLACK BR:BROWN
 BL:BLUE
 Y/G:YELLOW/GREEN

NOTE:1. Because of different compressor, the dotted part may not be used.
2. The parts are optional

9. Installation and repairing

Selection of the installation position

1. The air-conditioner is better installed in shadow or in a place with short period of sunshine. In case the air-conditioner is installed at the point exposed directly to the sunshine, it should be protected from the direct sunlight as possible in order to avoid the long time of direct sunlight otherwise its performance will be lowered. (As illustrated in Fig. 1)
2. For the convenience of operation, it is recommended that air-conditioner be installed at least at the height of 760-1300 mm above the floor and no obstacles before it for a free airflow.
3. The shutters at both sides and the top of air-conditioner should be protruded outdoors free from being blocked by wall, window, etc.
4. The back of air-conditioner should be kept over 500mm from the obstacles (for example, wall, etc.) (As illustrated in Fig. 2)
5. To have an efficient drainage, the back part of the air-conditioner should be inclined downward by 5-10mm (As illustrated in Fig. 3).

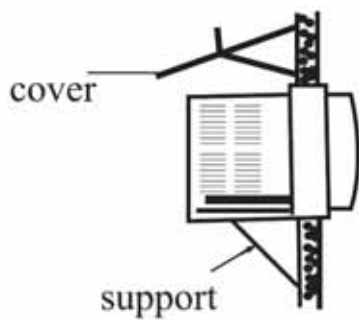

fig.1

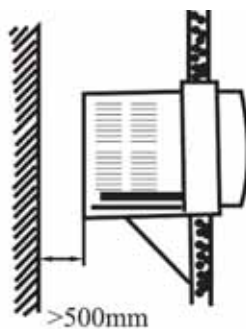

fig.2

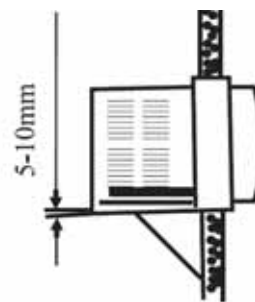

fig.3

The enclosed accessories of the conditioner are:

Name	Manual	Battery (R-03 dry battery)	Outlet pipe fitting	Sealed gasket	Drain pan	Screw	Remote controller
Figure							
Quantity	1	2	1	1	1	2	1

1. Make the wall hole or window hole (see Fig. 4)

MODEL	A	B
HW-09LN03 HW-07LN03	355mm	471mm
HW-12LN03	381mm	600mm

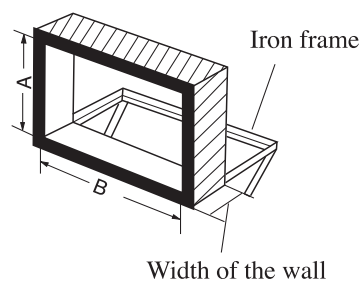

Fig. 4

2. Fix the prefabricated iron frame to stable position by expansible screws.

3. Take out the conditioner and accessories from the package .

4. Lift the back of the machine body slightly. You can see the drain hole at the back of the bottom plate. Plug the black rubber lid of the enclosed accessories into the hole. (see Fig. 5).

5. Plug the drain elbow of the enclosed accessories (with seal ring) into the drain hole on the vertical wall at the back of the bottom plate (see Fig. 6)

6. If you need to lead the condensed water to indicated position, please purchase a piece of plastic pipe with inner diameter of $\Phi 16$, set it on the drain elbow and tie it tightly.

7. After installation of all the accessories, put the whole machine on the iron frame. If there's extra pipe, lead the pipe to needed position (see Fig7).

8. Fill any distance between the wall hole and the machine body with flexible sponge rubber strip to prevent the entering of outer noise and the leaking of the coolness.

9. After installation of the conditioner, insert the power plug into the outlet and perform test-run.

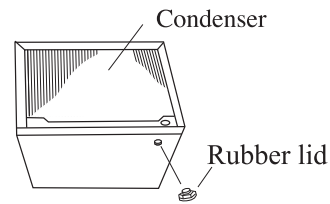

Fig. 5

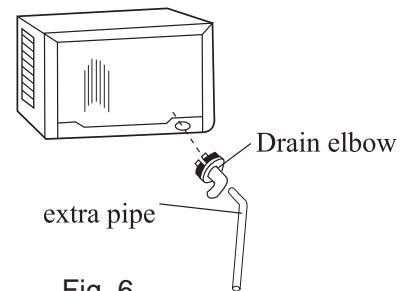

Fig. 6

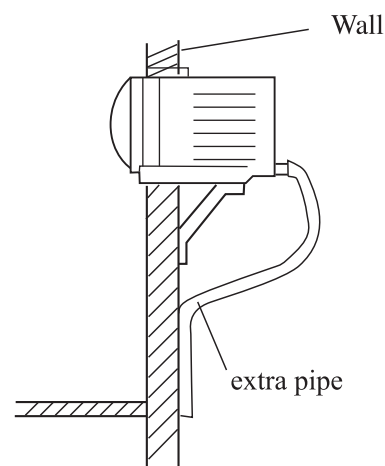
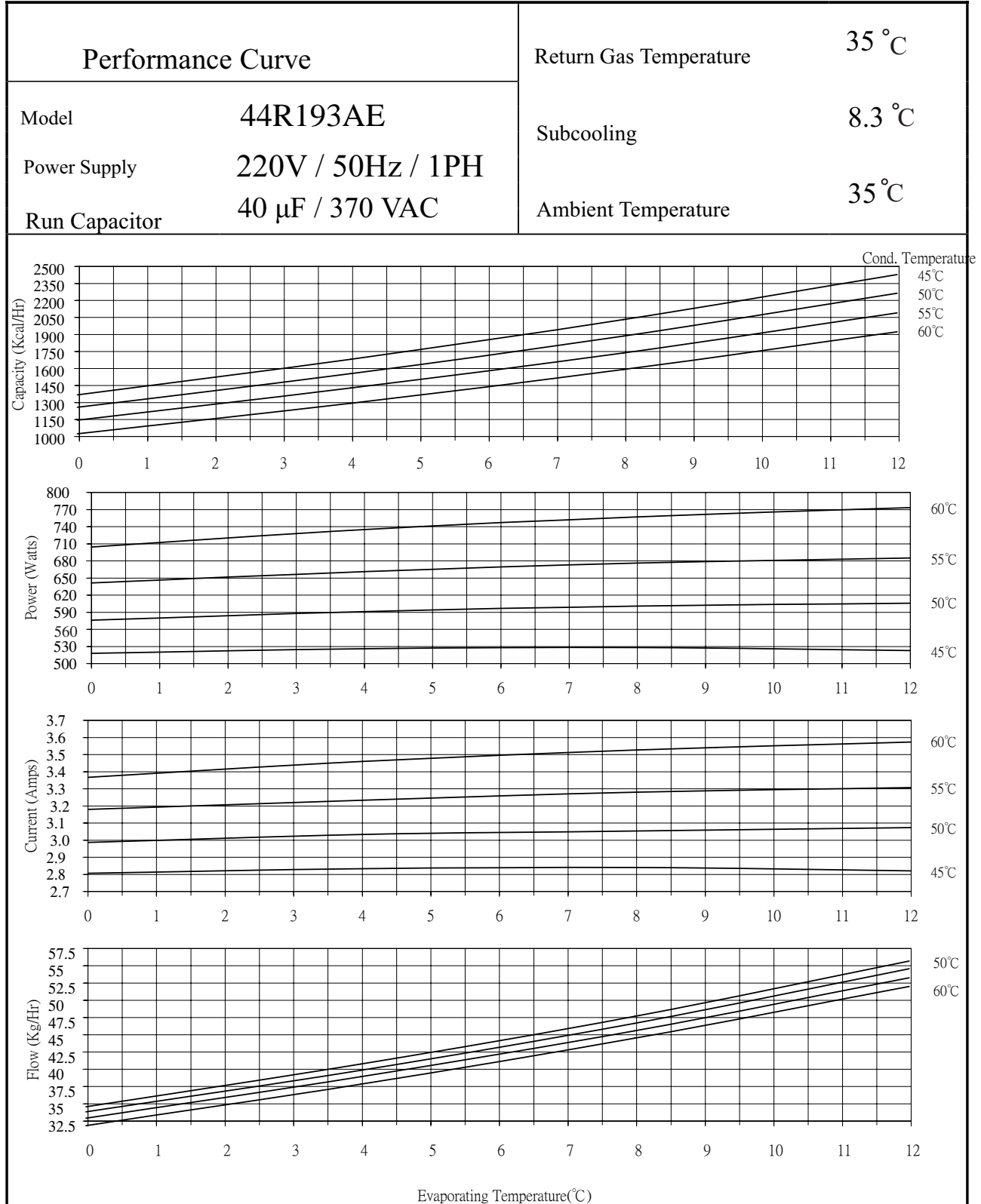

Fig. 7

10. Compressor performance diagram

HW-07LN03



HW-09LN03

Appendix 3. Performance Curve		Return Gas Temperature	35°C
Model	44R233C	Subcooling	8.3°C
Power Supply	220V / 50Hz / 1PH	Ambient Temperature	35°C
Run Capacitor	25 μF / 370 VAC		

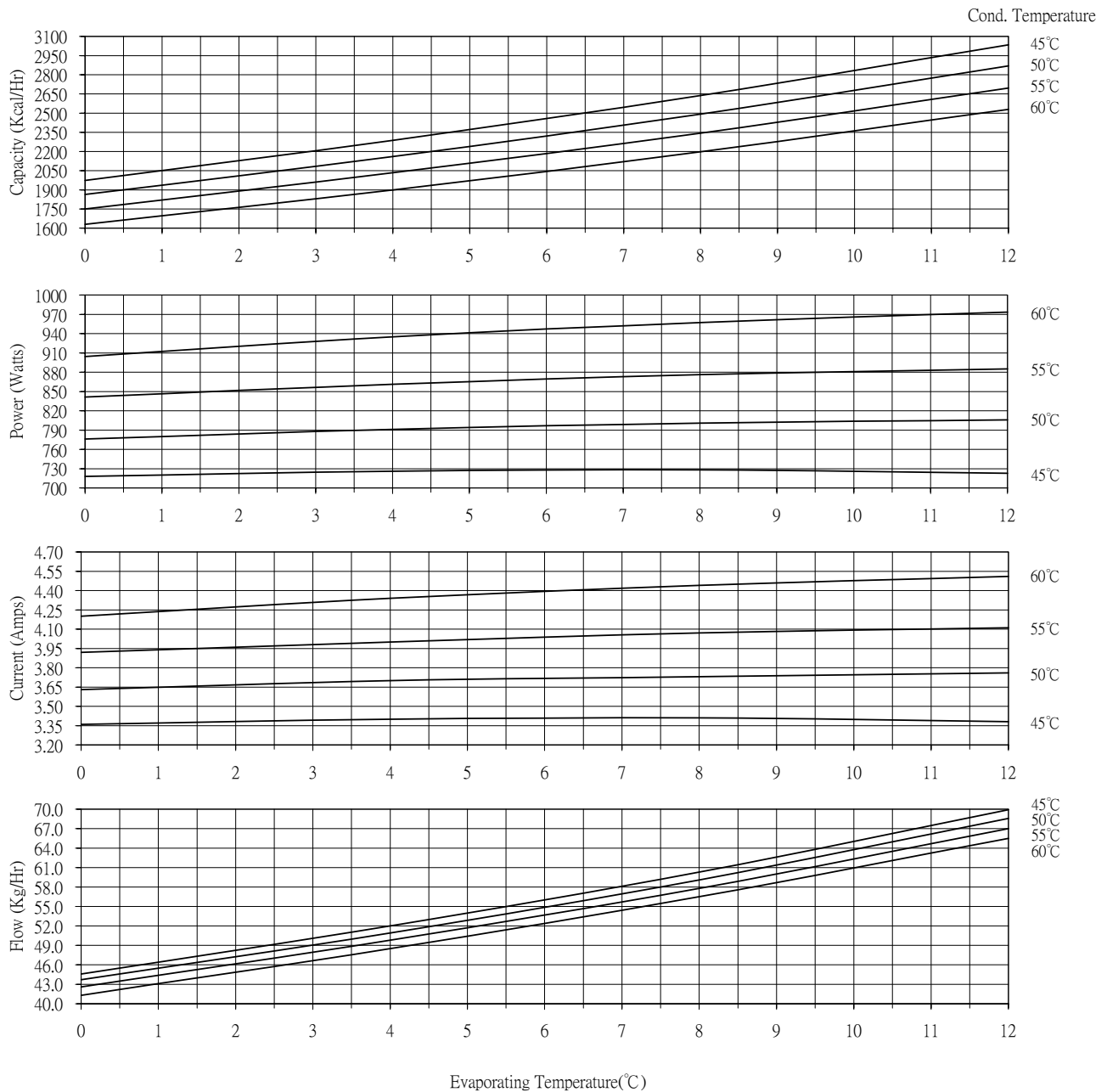

Sincere Forever

Haier Group

Haier Industrial Park, No.1, Haier Road

266101, Qingdao, China

<http://www.haier.com>