

## Horizontal and concealed type Fan Coil Service Manual

---

Models:

FCE-034B**	FCE-051B**	FCE-068B**
FCE-085B**	FCE-102B**	FCE-136B**
FCE-170B**	FCE-204B**	FCE-238B**



### ● Features

- Security and reliability, long life
- High efficiency , sufficient energy
- Large air volume and low noise level
- Universal application

## CONTENTS

Contents.....	2
1. Nomenclature.....	3
2. Important cautions.....	4
3. Features.....	4
4. Specification.....	5
5. Dimension and weight.....	6
6. Installation instructions.....	8
7. Installation inspection and startup.....	9
8. Maintenance.....	10
9. Troubleshooting.....	11
10. Wiring diagram.....	11



### 2. Important cautions

2.1 Fan coil unit is the terminal device of the chiller system. It is professional very much and with perfect technology and requirement, so the installation, debugging, operation and management will be performed by the specified engineer.

2.2 The unit is applicable widely. But please do not use it at the wet place, or on the outside, dirty, or corrosive environment, and at the explosive place.

2.3 Applicable condition

Power source: 1PH, 220V~, 50Hz.

Max. operation pressure  $\leq$  1.6MPa.

### 3. Features

3.1 Fan coil unit is mainly composed of centrifugal fan, motor and evaporator. which is used widely in the field such as the hotel, the restaurant, the hospital, the exhibition hall and the office building or industrial building and domestic building, etc. It will give you a comfortable environment.

3.2 Security and reliability, long life

Each set of fan coil evaporator will be tested leakage by pressure; water inlet/outlet connection pipe adopts brass forging structure, reliable and durable; the drain pan is made from mold and then treated with paint, stainless; motor is equipped with the rolling bearing, no need to add the oil, the life can be up to 60,000 hours; the motor long axis is stainless after the special treatment.

3.3 High efficiency, sufficient energy

The seamless pipe is cross the slit fin aluminum foil, then be enlarged by the mechanical device to make the copper pipe and the aluminum foil together, which will get the higher efficiency and sufficient heating/cooling capacity.

3.4 Large air volume and low noise level

The unit adopts the locked type scroll case, convenient to be taken down; multiple-blade fan. There will be multiple combinations by the fan and the motor to meet the different requirements.

3.5 Universal application

The unit adopts the drawable heat exchanger, convenient to maintain; optional left or right water inlet type, flexible installation; optional static external pressure 0Pa or 30Pa to meet the personalization requirement.

### 4. Specifications (without air return box, standard drainage pan)

model			FCE-034B	FCE-051B	FCE-068B	FCE-085B	FCE-102B	FCE-136B	FCE-170B	FCE-204B	FCE-238B	
data												
air volume	m3/h	H	high	340	510	680	850	1020	1360	1700	2040	2380
		M	med	290	430	580	720	850	1120	1420	1700	1980
		L	low	230	340	460	560	680	880	1110	1320	1580
cooling capacity		H	high	2120	3040	3900	4820	5950	8300	9480	11720	13130
		M	med	1781	2621	3354	4193	5296	7138	8437	10314	11686
		L	low	1484	2215	2886	3519	4463	6059	7110	8790	9848
heating capacity		H	high	3534	4750	6300	7940	9800	12755	15600	18700	21360
		M	med	2969	3990	5418	7067	8624	11735	13416	16269	18583
		L	low	2544	3420	4662	6034	7448	10076	11544	14025	16020
power input	W	H	high	24	32	50	61	81	120	148	178	198
		SH	super high	42	50	65	95	110	135	183	210	260
noise level	DB(A)	SH	super high	37	38	41	44	45	46	48	48	49
		H	high	35	36	37	41	43	43	46	48	48
		M	med	28	29	31	32	35	35	36	36	37
		L	low	22	22	24	25	26	27	28	28	29
water flow	l/min		6	9.1	12.5	14	16.2	23	26	34	38	
water pressure drop	kpa		10	16	18	23	35	35	38	39	46	
net weight	kg		11.9	13	14.8	17.8	18.3	29	29.3	33.4	33.6	
gross weight	kg		15.3	15.5	17.6	21.2	21.7	33.2	33.5	40.7	40.9	
water inlet/outlet connection pipe			3/4"inner grooved									
condensate water connection pipe			3/4"outer grooved									
external dimension(L*W*H)			624*466*220			944*466*220			1374*466*220		1634*466*220	

- 1.Cooling conditions: DB temperature=27℃ WB Temperature=19.5℃ water IN=7℃ water IN/OUT Diff=5℃
- 2.Heating conditions: DB temperature=21℃ water IN=60℃
- 3.The left water outlet type or right water outlet type unit can be changed on site according to the actual requirement
- 4.The static pressure 0 Pa and 30 Pa can be selected freely according to the actual requirement
- 5.The data is subject to change without notice in order to update the design

### 5. Dimension and weight

Horizontal and concealed type, without air return box:

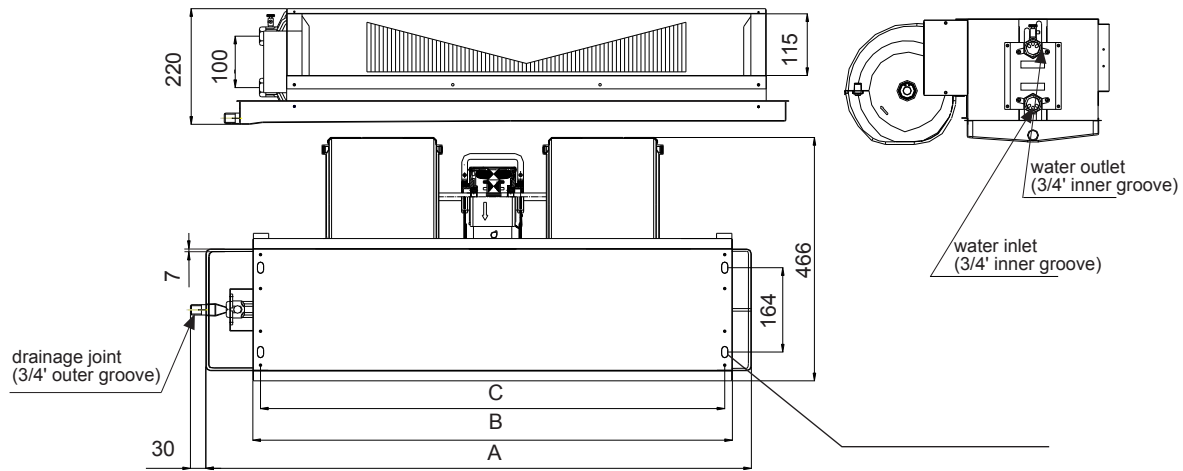

standard drainage pan					extended drainage pan				
model	external dimension(mm)			weight (kg)	model	external dimension(mm)			weight (kg)
	A	B	C			A	B	C	
FCE-034BCN2A	624	508	478	11.9	FCE-034BCN2B	944	508	478	12.4
FCE-051BCN2A	624	508	478	13	FCE-051BCN2B	944	508	478	13.1
FCE-068BCN2A	944	808	778	14.8	FCE-068BCN2B	1084	808	778	15.1
FCE-085BCN2A	944	808	778	17.8	FCE-085BCN2B	1084	808	778	17.9
FCE-102BCN2A	944	808	778	18.3	FCE-102BCN2B	1084	808	778	18.4
FCE-136BCN2A	1374	1238	1208	29	FCE-136BCN2B	1634	1238	1208	29.1
FCE-170BCN2A	1374	1238	1208	29.3	FCE-170BCN2B	1634	1238	1208	29.4
FCE-204BCN2A	1634	1498	1468	33.4	FCE-204BCN2B	1754	1498	1468	33.5
FCE-238BCN2A	1634	1498	1468	33.6	FCE-238BCN2B	1754	1498	1468	33.7

Horizontal and concealed type with back type air return box:

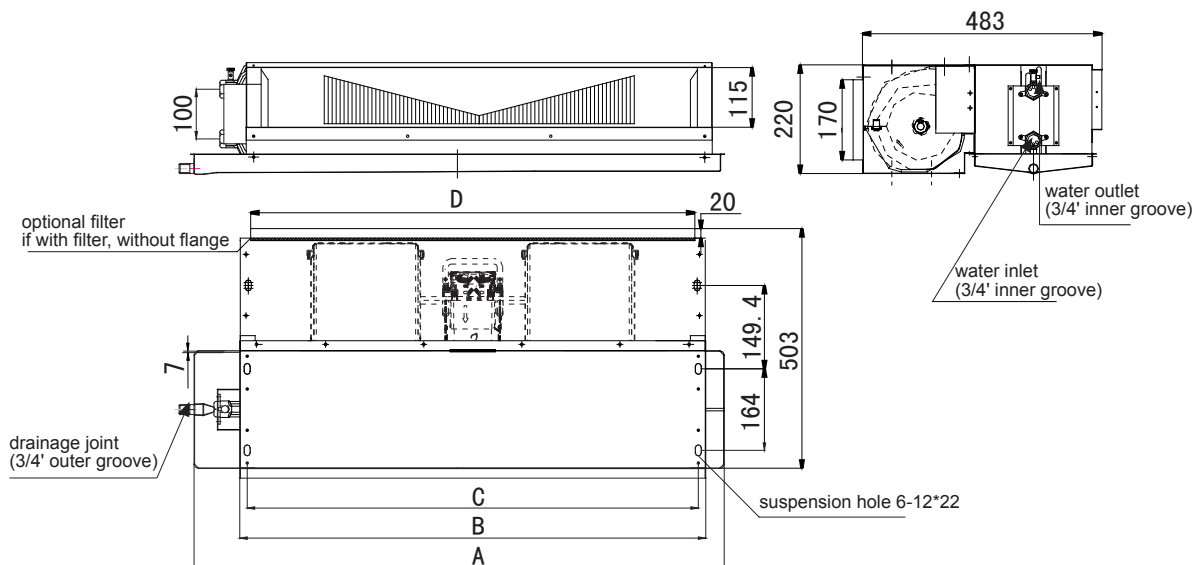

standard drainage pan						extended drainage pan					
model	external dimension(mm)				weight (kg)	model	external dimension(mm)				weight (kg)
	A	B	C	D			A	B	C	D	
FCE-034BCB2A	624	508	478	451	14.4	FCE-034BCB2B	944	508	478	451	15.4
FCE-051BCB2A	624	508	478	451	14.5	FCE-051BCB2B	944	508	478	451	15.5
FCE-068BCB2A	944	808	778	751	18.3	FCE-068BCB2B	1084	808	778	751	18.8
FCE-085BCB2A	944	808	778	751	18.5	FCE-085BCB2B	1084	808	778	751	19
FCE-102BCB2A	944	808	778	751	18.6	FCE-102BCB2B	1084	808	778	751	19.1
FCE-136BCB2A	1374	1238	1208	1183	28.5	FCE-136BCB2B	1634	1238	1208	1183	29.4
FCE-170BCB2A	1374	1238	1208	1183	28.7	FCE-170BCB2B	1634	1238	1208	1183	29.6
FCE-204BCB2A	1634	1498	1468	1443	34.5	FCE-204BCB2B	1754	1498	1468	1443	34.9
FCE-238BCB2A	1634	1498	1468	1443	34.9	FCE-238BCB2B	1754	1498	1468	1443	35.3

### Horizontal and concealed type with down type air return box:

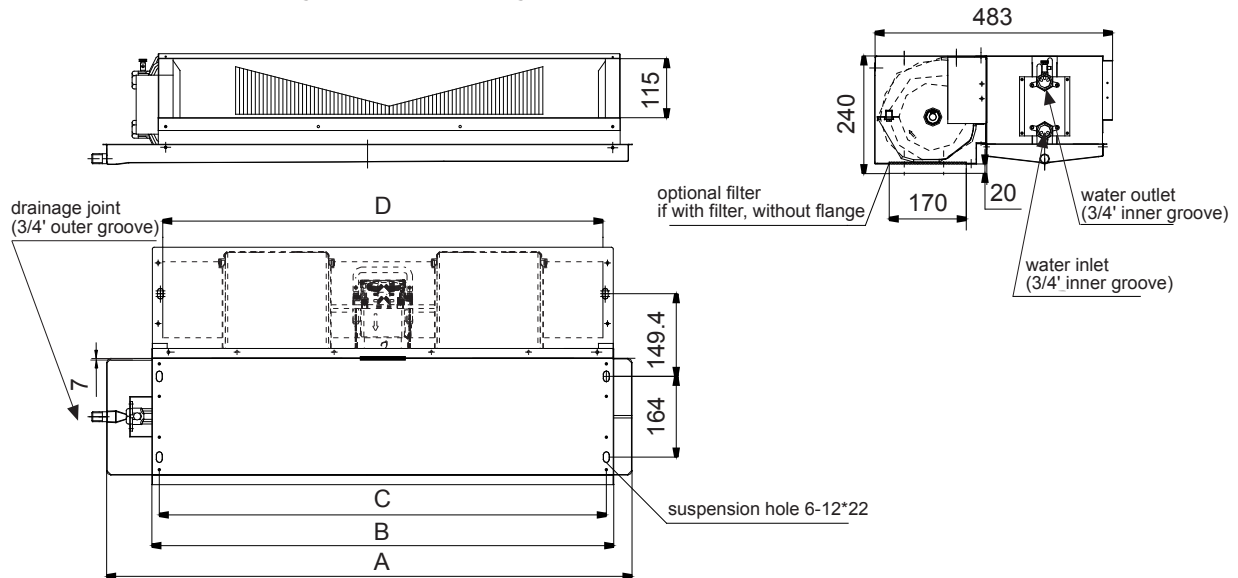

standard drainage pan						extended drainage pan					
model	external dimension(mm)				weight (kg)	model	external dimension(mm)				weight (kg)
	A	B	C	D			A	B	C	D	
FCE-034BCD2A	624	508	478	451	14.4	FCE-034BCD2B	944	508	478	451	15.4
FCE-051BCD2A	624	508	478	451	14.5	FCE-051BCD2B	944	508	478	451	15.5
FCE-068BCD2A	944	808	778	751	18.3	FCE-068BCD2B	1084	808	778	751	18.8
FCE-085BCD2A	944	808	778	751	18.5	FCE-085BCD2B	1084	808	778	751	19
FCE-102BCD2A	944	808	778	751	18.6	FCE-102BCD2B	1084	808	778	751	19.1
FCE-136BCD2A	1374	1238	1208	1183	28.5	FCE-136BCD2B	1634	1238	1208	1183	29.4
FCE-170BCD2A	1374	1238	1208	1183	28.7	FCE-170BCD2B	1634	1238	1208	1183	29.6
FCE-204BCD2A	1634	1498	1468	1443	34.5	FCE-204BCD2B	1754	1498	1468	1443	34.9
FCE-238BCD2A	1634	1498	1468	1443	34.9	FCE-238BCD2B	1754	1498	1468	1443	35.3

### 6 . Installation instruction

#### Inspection when receipt

Each fan coil unit is packed with the carton to prevent being damaged in the transportation or installation.

Please check the following items:

- 1.Before receipt, check if there is abnormal phenomenon, and if the carton is in good condition, or if there is obvious damage.
- 2.If the carton is damaged obviously, please unfold the carton to check the unit and its accessories.
- 3.Check the unit hidden damage.
- 4.If the hidden damage is found, please do not move the unit and the specialist will check if the damage occurs before or after the delivery.
- 5.If damage occurs, please inform the carrier. The carrier and the consignee must have an inspection together.
- 6.Please do not modify the unit before the responsibility is confirmed.

#### Safety precaution

To ensure the installation and the operation favorably, please check the below items before installation:

- 1.The unit should be enough space for installation and maintenance; please refer to the unit exterior dimension figure; there should be movable ceiling or check hole for daily maintenance.
- 2.Before installation, please confirm the pipe and electric wiring position.
- 3.Check if the suspension device is strong enough to support the unit.
- 4.All the units must be installed horizontally to ensure the water drainage smoothly and the normal operation.
- 5.The unit connecting the duct should be in the allowable external static pressure range.
- 6.The freezed water valve and the heat insulation will be supplied by the installer.

#### Installation

The installation can be performed according to the dimension figure and the installation figure. It can be mounted on the ceiling through the suspension pole, please perform as follows:

- 1.Install the suspension pole or other similar devices.
- 2.Tighten the upper screw and the washer, make the unit not move in operation.
- 3.Put the suspension pole into the suspension holder of the unit.
- 4.Tighten the lower screw and the washer to fix the unit, keep the unit horizontal to ensure the condensate water can flow out, and then tighten the upper screw.

#### Freezed water pipe connection

Connect the duct made of galvanized steel plate to the flange on the inlet/outlet frame. Please refer to the dimension figure, inset the duct into the flange and fix them with the screws. If the dimensions of both sides are different, connect them with the changing connector.

Connect the freezed water pipe to the coil with 3/4" outer grooved connector. Water inlet pipe is upper, and water outlet pipe is lower. The dimension is shown in the figure.

#### Condensate water pipe connection

The condensate water pipe can be PVC material or made of steel, connect the pipe to the drain pan with 3/4" inner grooved connector. At the connection, the adhesive tape against water leakage. The gradient of the drainage pipe should be at least 1:50 as suggestion.

Note: The freezed water pipe and the condensate pipe must be heat preserved, and please take especial notice of the end of heat preservation material against the dew in cooling mode.



### Electric wiring

Electric wiring please refers to the wiring diagram.

The earthing point should be in the earthing system of the building.

All the wiring should comply with the local electric regulation.

Note: Before maintenance, please cut off the power source to avoid the person being injured. The wire should be copper conductor, because other conductor will result in over heat and the unit being damaged.

If the unit is in ceiling concealed type, the air return box must be installed, as the figure:

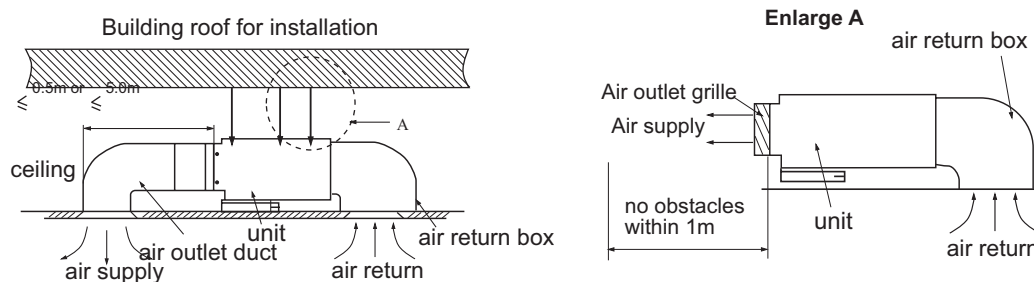

The distance between the duct air outlet and the air conditioner air outlet will depend on the actual duct length and the actual static pressure terminal:

Installation of long/short duct is shown in below figure; when short duct is connected, the motor will use the low static pressure terminal, and the distance should be no more than 0.5m; when long duct is connected, the motor will use the high static pressure terminal, at this time, the distance should be no more than 5m.

Note: When in low static pressure, connect the high/med/low terminal to the 3-speed switch( or fan coil controller); when in high static pressure, connect the super high/high/med terminal to the 3-speed switch ( or fan coil controller); one 3-speed switch( or fan coil controller) only can control one set of fan coil unit.

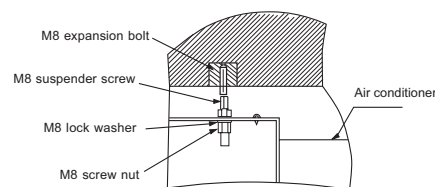
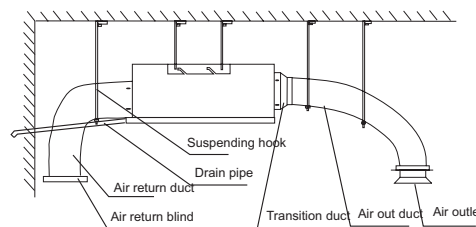

## 7. Installation inspection and startup

### Installation inspection

Before startup, please cut off the power source to avoid injury.

- 1.The unit must be fixed firmly with the suspension pole and the ceiling or roof.
- 2.Air duct should be installed firmly.
- 3.Water pipe should be connected well and there is no leakage.
- 4.Drainage pipe should be connected well and there is no leakage.
- 5.Electric control system is connected completely, and there is no bad connection or leakage.
- 6.Finish reading the operation manual, and familiar with the unit.

### Startup

The fan coil unit can be controlled by the fan speed switch or the thermostat.

The thermostat includes one fan speed switch, one ON/OFF switch and one temperature control element. The element can control the frozen water switch and one temperature setting dialing switch. And the fan speed switch is marked with "OFF/high/med/low", which can control motor speed, further to control the air volume.

### Discharging operation

When the system is filled with water for the first time, there will be some remaining smell in the system, which will concentrate on the top of fan coil. The water outlet connector of fan coil is equipped with the manual discharging valve. When there is remaining smell in the fan coil, the unit will sound abnormal noise. Turning the discharging valve exhausts the air; if the valve is too fast, you can turn it with a plier at counter-clockwise until the steady water is exhausted from the valve, then tighten the valve.

## 8. Maintenance

Before maintenance, please cut off the power source to avoid injury.

Every month Check if the drainage pan is clean and if the condensate water can flow to the drainage pipe smoothly.

- Every year
1. Check if the outer case is dusty, please clean and maintain it.
  2. Check if the fan blade and the scroll case is damaged, turn the fan blade by hand to ensure there is no obstacle to stop it.
  3. Check if the coil fin is too dirty or damaged.
  4. Clean and tighten all the wires.
  5. Exhaust all the frozen water in the system, then move away the dirt.

### Note:

1. The non-treated water will result in the dirt, the corrosion and poor performance; the system debugging and the maintenance should be executed by the specialist.
2. For the limited bracket weight and the dimension, the maintenance should be executed by two persons to ensure safety.
3. If the unit stops running, the water in system should be exhausted to avoid icing in the pipe, which will break the pipe.

### Clean the coil

The blocked or dirty coil will lower the cooling capacity. Please perform as follow:

1. Cut off power source and motor wire, and make the fan stop running.
2. Loosen the screw between the side plate and the drainage pan.
3. Separate the shell and the drainage pan, and loosen the screw between the fixing plate and the side plate.
4. Draw out the evaporator.
5. Clean the coil.
6. Re-assemble the evaporator and the drainage pan, and fix them with the screws.
7. Supply the electricity and the water to the unit, and check the effect.

### Drainage pan

The drainage pan must be cleaned in order to exhaust the condensate water.

### 9. Troubleshooting

Failure description	Reason	Solution
Too low air flow	Too dirty filter	Clean or replace
	Blocked air inlet/outlet	Smooth it
Large noise level	Motor bearing sounds	Modity or replace
Insufficient cooling /heating capacity	Dirty filter	Clean or replace
	Wrong water temperature	Adjust water temperature
	Low water flow	Increase water flow
	Low air flow	Increase air flow
	Blocked water pipe of drainage pan	Smooth it
Water leakage	Bad heat insulation of pipe	Heat preservation
	Unit not horizontal	Make it keep horizontal
	Cracked heat exchanger	Modity or replace

### 10 Wiring diagram

