

AIR-COOLED MODULE CHILLER

Operation and Installation Manual

CA0100AANB

CA0100MANB

No.0010578635

D

- Before using the air conditioner, please read this manual carefully.
- Please keep this manual for future use.



Product Profile & Table of Contents

Product Profile

The advantages of air-cooled module (heat pump) chiller main features are: easy installation and operation; convenient operation by simply connecting to the power supply; saving the complication of a complete set of cooling water system and boiler heating system.

The unit is characterized by its dual functions of supplying cold water in summer and hot water in winter (only available for heat pump model). A large volume of water is saved through the use of air as heat and cold source and water pollution is avoided. The air-cooled module (heat pump) chiller can be installed on the top of building roof or outdoor platform, which dispenses with the construction of chiller room and boiler room.

Table of Contents

Product Profile & Table of Contents.....	1
Basic Cooling Principle.....	2
System Diagram.....	3
Unit Specifications.....	4-6
Exterior Dimension.....	7
Unit Installation.....	8-11
Controller Operation Instruction.....	12-19
Instructions of electric connection.....	20
Maintenance & Service.....	21

Basic Cooling Principle

Basic Cooling Principle

Generally the natural matter exists in three states: gas, liquid and solid. When the state of the matter changes, generally energy transfer accompanies with it. When matter changes from liquid to gas, it needs to absorb energy; changing from gas to liquid needs to release energy; for example in Summer, when applying some water on the skin, and the water volatilizes into gas, it takes energy away from the skin, so that the skin feels cool.

When we invent a kind of equipment, which can make a matter not only change from liquid to gas, but also change from gas to liquid, and cycle repeatedly, thus it can realize continuous cooling and heating. The matter of this kind of cycle is refrigerant, and the unit is the right equipment to realize this kind of energy transformation. It consists of compressor, air side heat exchanger, water side heat exchanger and expansion valve, The refrigerant is R22.

In cooling, the liquid refrigerant is gasified in the water side heat exchanger, absorbing heat from water to make water drop. After being compressed by the compressor, the refrigerant gas of low temperature and pressure becomes high temperature and pressure gas and enters air side heat exchanger; because the refrigerant temperature is higher than the air temperature, the refrigerant transfers heat to the air, and refrigerant condenses from gas to high pressure liquid; throttled by passing through the expansion valve, the high pressure liquid refrigerant flows into water side heat exchanger; then the low pressure liquid refrigerant is gasified again, thus a cycle is finished. In this cycle, with the transformation of the refrigerant, it realizes heat transfer from water side to the air side.

In heating, liquid refrigerant is gasified in the wind side heat exchanger absorbing heat from the air; after being compressed by the compressor, the gas refrigerant of low temperature and pressure becomes high temperature and pressure gas and is delivered to the water side heat exchanger, because the refrigerant temperature is higher than water temperature, the refrigerant is refrigerated from gas to liquid; after being throttled by the expansion valve, the liquid refrigerant enters air side heat exchanger, then the low pressure liquid refrigerant is gasified again, thus a cycle is finished. In this cycle, with the transformation of the refrigerant, it realizes the heat transformation from air side to water side.

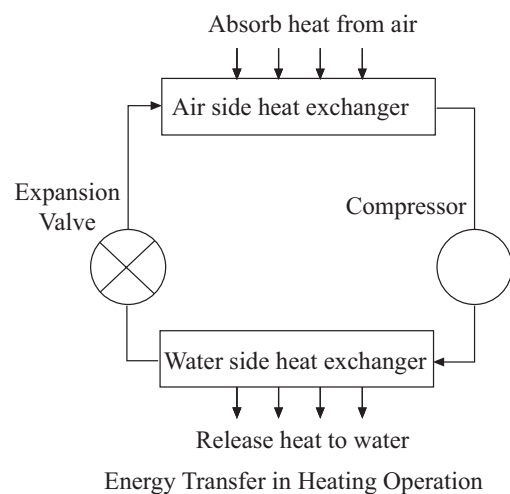
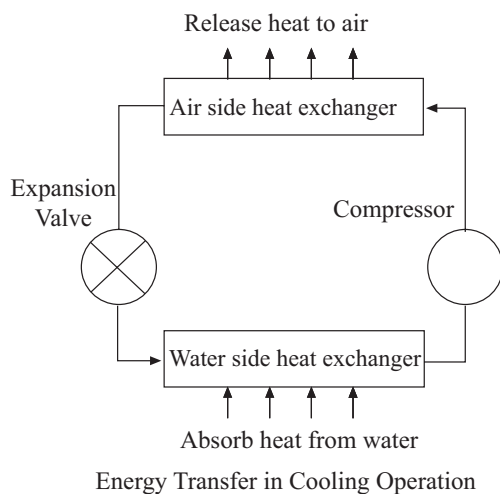

System Diagram

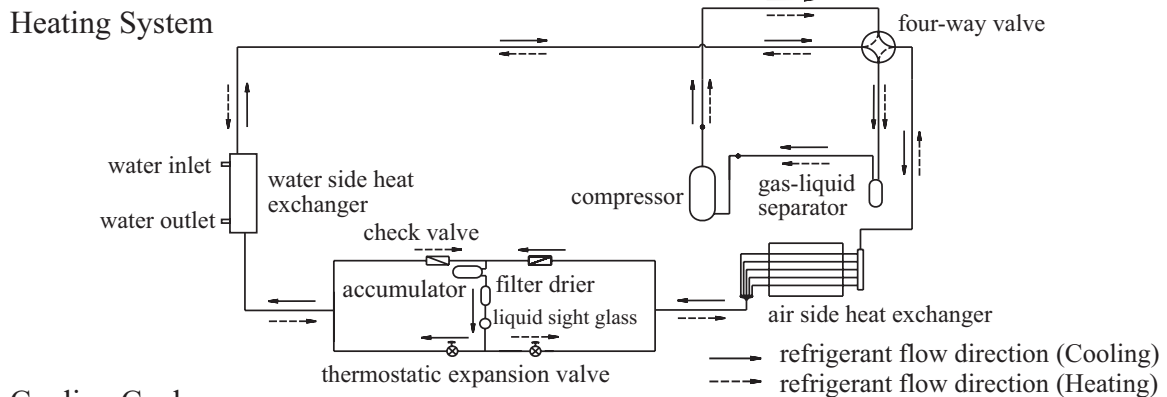
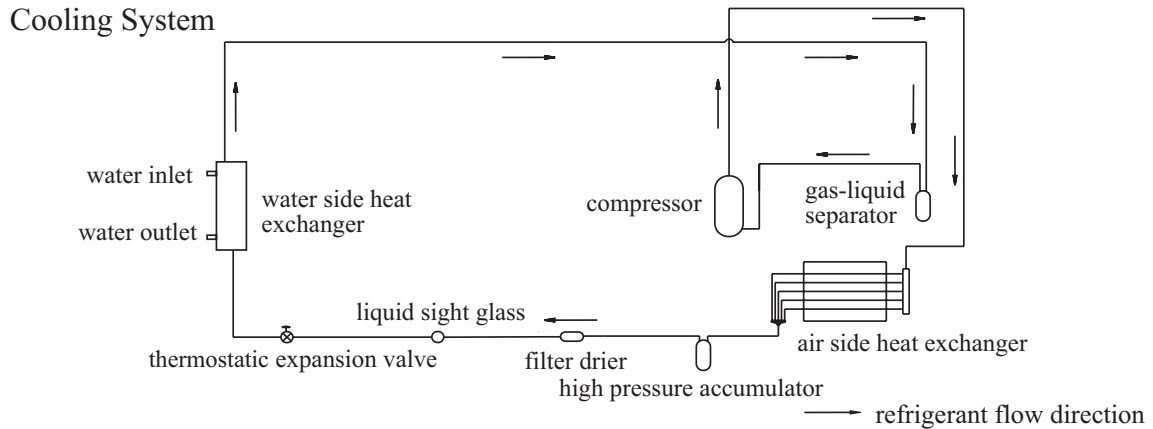

Cooling Cycle

When unit operates in cooling mode, compressor sucks in low-pressure refrigerant gas from gas-liquid separator, compresses it and discharges high pressure gas. The gas goes through four-way valve and arrives at the airside heat exchanger, where air circulation driven by fan takes away heat and cools the gas down to high pressure liquid. Gathering through separator, the gas flows into accumulator through check valve. At this time, uncondensed gas will fill the upper part of accumulator. The liquid, going through the drier filter at the bottom of the accumulator, has water and impurity in it removed. On going through the liquid sight glass, the liquid arrives at the expansion valve, through which high pressure liquid is reduced to low pressure refrigerant by way of expansion valve regulation and then enters water side heat exchanger. Here, refrigerant vaporizes by absorbing heat from heat exchanger copper pipe, while water outside the copper pipe cools down and reaches the temperature required for the operation. The low-pressure gas comes out of the waterside heat exchanger, goes through the four-way valve and enters gas-liquid separator. Then, the gas flows from the gas-liquid separator to compressor suction inlet, which process ensures that fluid returns to compressor is no other than gas. Thus, a cooling cycle is completed.

Heating Cycle

When unit operates in heating mode, compressor sucks in low-pressure refrigerant gas from gas-liquid separator, compresses it and discharges high-pressure gas. The gas goes through four-way valve and arrives at the waterside heat exchanger, where high-pressure gas releases heat and turns into high-pressure liquid, while water outside the copper pipe is heated up and reaches the required temperature for operation. The high-pressure liquid goes through check valve and enters the accumulator. At this time, uncondensed gas will fill the upper part of accumulator. The liquid, going through the drier filter at the bottom of the accumulator, has water and impurity in it removed. On going through the liquid sight glass, the liquid arrives at the expansion valve, through which high pressure liquid is reduced to low pressure refrigerant by way of expansion valve regulation, then it enters airside heat exchanger through check valve and separator. Here, refrigerant liquid circulates in the copper pipe of heat exchanger and serves as a heat source. The low-pressure liquid vaporizes in airside heat exchanger and goes through four-way valve and then enters gas-liquid separator. The gas flows from the gas-liquid separator to compressor suction inlet, which process ensures that fluid returned to compressor is free of other gas. Thus, a heating cycle is completed.

Unit Specifications

● Unit Specifications

Model		CA0100AANB	CA0100MANB
Nominal Cooling Capacity	kW	98	98
Nominal Heating Capacity	kW	105	——
Refrigerant charge (R22)	kg	30	
Max. running Current	A	67.5	
Power Supply	3N~,380V,50Hz		
Operation Control Method	Automatic		
Safety Protection	High/low Pressure Protection, Water Lackage delay Protection, Freeze Protection, Overload & Overheat Protection, Phase Loss, Phase Sequence Protection		
Compressor	Type	Flexible Scroll Type	
	Quantity	3	
	Rated Power	kW	10.1×3
Fan Motor	Type	Specially designed Fan & Motor	
	Quantity	3	
	Rated Power	kW	0.75×3
Dimension	Length	mm	2635
	Width	mm	1350
	Height	mm	2136
Water Side Heat Exchanger	Tube and shell Type Heat Exchanger, Working Pressure 1.0MPa		
Air Side Heat Exchanger	Inner Grooved Copper Tube String Hydrophilic Aluminium Finned coil		
Water Flow	m ³ /h	18	
Water Resistance	kPa	50	
Water Pipe Inner Diameter	DN	65	
Unit Net Weight	kg	1100	
Unit Running Weight	kg	1150	

- Note: 1. Nominal Cooling Working Condition: water inlet temp. 12°C, water outlet temp. 7°C, ambient temp. 35°C.
 2. Nominal Heating Working Condition: water inlet temp. 40°C, water outlet temp. 45°C, ambient temp. : (DB) 7°C, (WB) 6°C.
 3. Unit Operation Range: -7~43°C.
 4. Cycling Water fouling Factor 0.018m²·°C/kW be combined.
 5. Sixteen modules can combine at the maximum.

When multi modules be connected, the total water inlet and outlet pipes dimensions are as :

Module Qty	2	3	4	5	6	7	8	9	10	11	12	13	14	15	16
Pipe dimensions	65	80	100	100	125	125	150	150	150	200	200	200	250	250	250



Unit Specifications

- Variable working condition cooling capacity and input power curves

Ambient Temperature (°C)

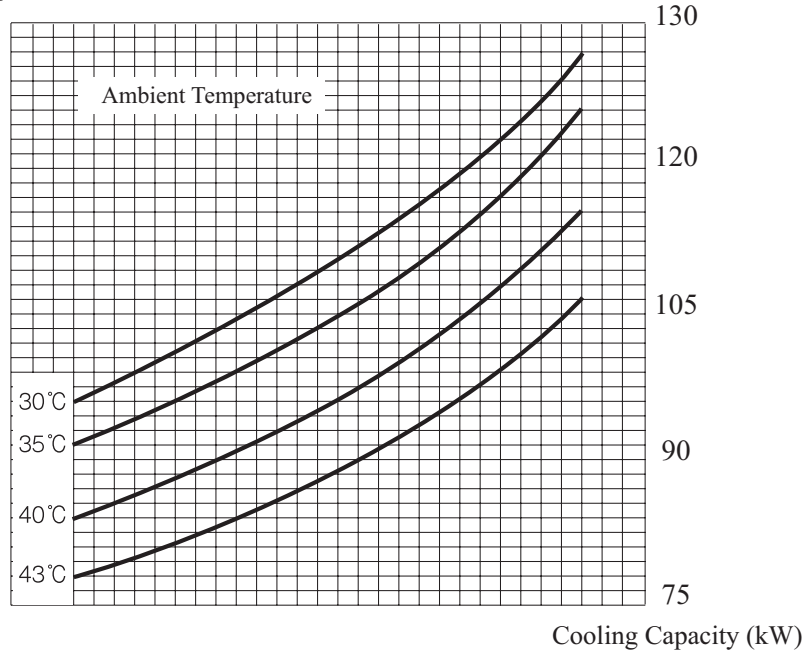

Power Input (kW)

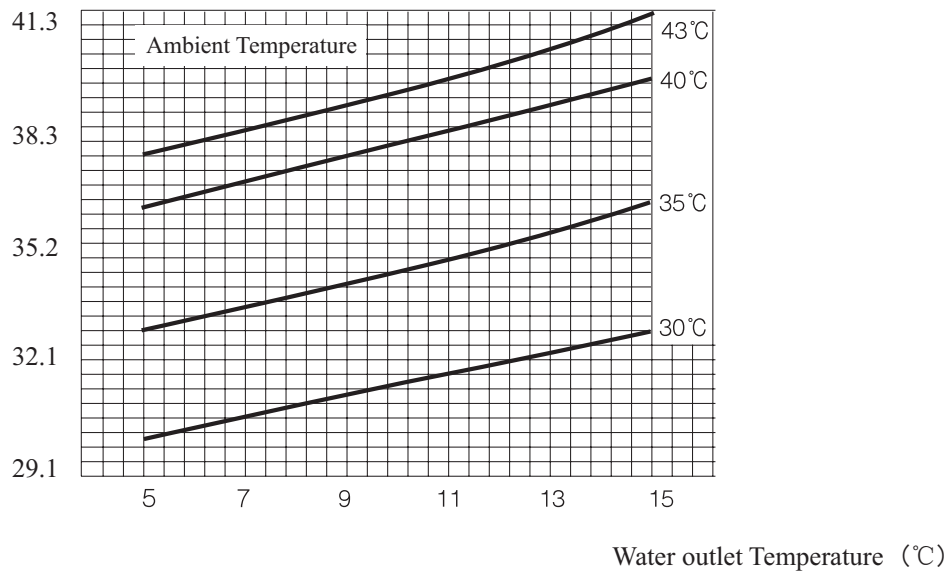



Unit Specifications

- Variable working condition heating capacity and input power curves

Ambient Temperature (°C)

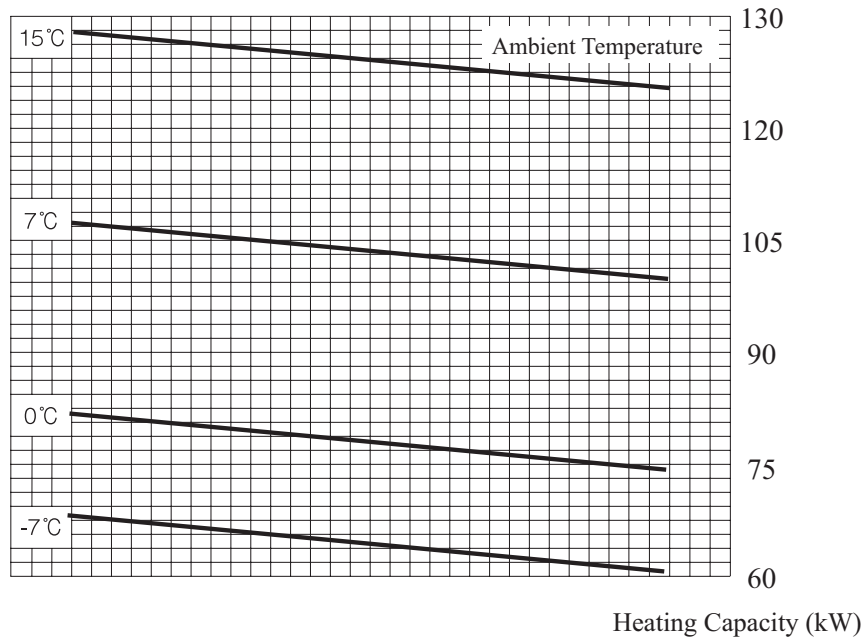

Power Input (kW)

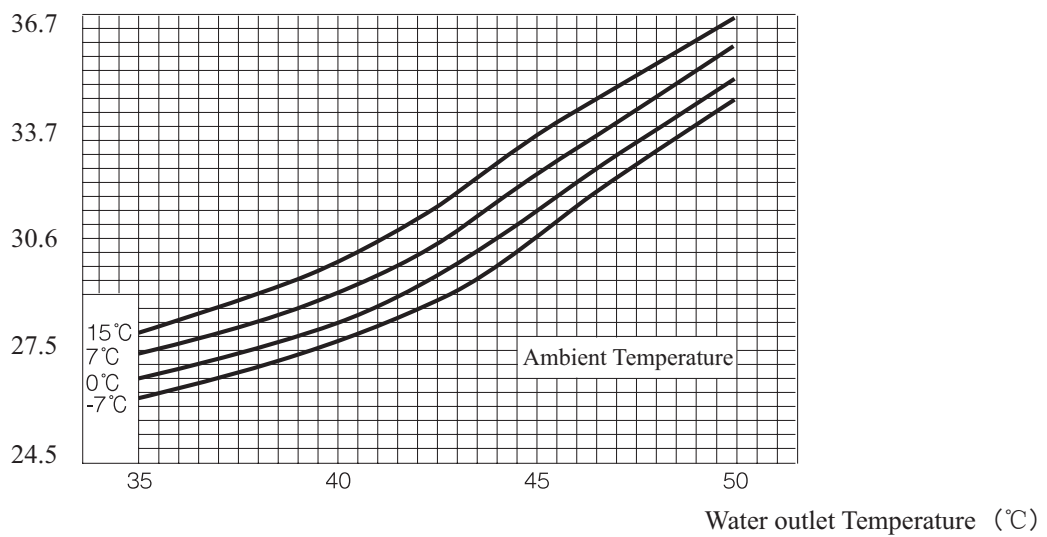

Exterior Dimension

● Exterior Dimension (Unit: mm)

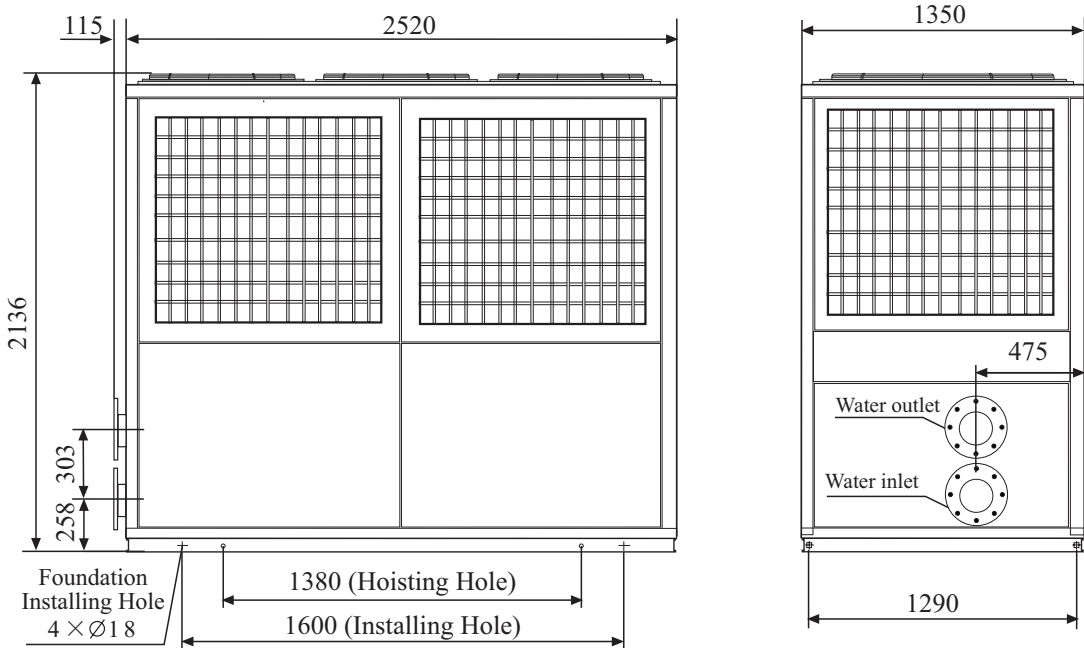

● Recommended Foundation Position

1. Foundation load bearing is calculated based on weight of the unit in operation.
2. The foundation may be constructed with channel bars (users may formulate their own design based on the outer dimension of the unit) or concrete-structured. The surface should be smooth.
3. Add a 10~20mm rubber damping pad between the unit and the foundation.
4. It is appropriate to fix the unit on the foundation with $\varnothing 16$ or $\varnothing 18$ base bolts.

(Unit: mm)

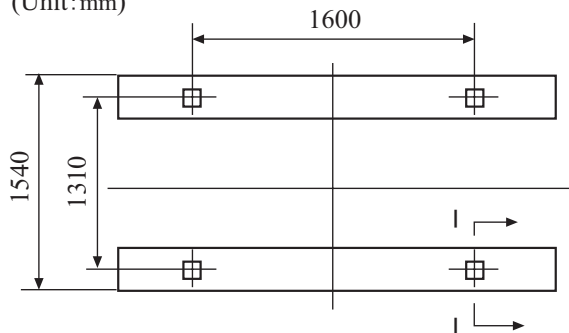

I-I cutaway view

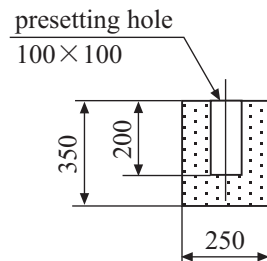

Unit Installation

● Freight Check

All the units are tightly fastened on the wood pallet by the bolts. Before leaving factory, the units are all checked and prefilled with R22 refrigerant and refrigerant oil, both of which are the precise amount the unit operation needs. When user receives the product, he shall check it carefully to confirm if there is product damage in transportation and to confirm all the preordered parts are received.

If there is any damage, he shall immediately inform the delivery man and claim for compensation according to relevant clauses. If there is problem except for surface damage, he shall immediately inform our company.

● Carry the Unit

In order to be convenient to carry the unit, the user shall use forklift or crane. When using crane, there shall be proper partition to protect the top and side panel of the unit (as Figure shown). During carrying, the unit shall be kept level, and the gradient shall not exceed 30° . Try to avoid units damage due to improper operation.

● Dismantle the Unit

After putting the unit in the needed position, cut the packing strap and remove the outer crate. Unscrew the tightening bolt and remove the wood pallet from the bottom of the unit.

● Selection of Installation Place

1. The installation place shall be level, the foundation surface shall be flat, and the supporting surface can bear the operating weight of the unit.
2. The unit shall not be installed in a place where there is too much dust, corrosive gas, high humidity or there easily gathers insects, fallen leaves and other contaminative matters.
3. It is suggested to maintain servicing space more than 400mm between units.
4. There shall leave over 1.5m spaces around the unit to be convenient for ventilation and equipment maintenance.
5. Try to keep the unit away from sunshine and rain, it is recommended to cover the unit with rainproof and sunproof shed, but it shall be guaranteed there is a space over 3m above the air outlet for easy heat release.
6. A 10~20mm rubber anti-vibration cushion shall be equipped between the unit and the foundation, after adjusting level, then fasten the anchor bolt.
7. For the heat pump type unit, there shall be drained around it to drained the defrosting condensed water.
8. The installation and thermal insulation of the water pipes of the air conditioning system shall be designed and instructed by the professionals and shall implement the relevant regulations of the Installation Standard for HV& AC.
9. The external water pipe system must be equipped with anti-vibration hose joint, water filter, electronic cleaner, check valve, drain valve, air release valve, stop valve and expansion tank, etc. The expansion tank shall be installed 1~1.5m higher than the system top, and its capacity is about 1/10 of the total water amount of the system. The air release valve shall be installed between the top of the system and the expansion tank, and the water tank and the pipe shall be thermal insulated.
10. Water pump with adequate flow capacity and lift should be selected to match the water supply system to ensure normal water supply to the unit. Only soft water can be used as circulation water.
11. Before the water pipe of the unit must install a water filter and select 16-40-mesh filter.
12. Water pump and unit, water pump and system water pipe shall use anti-vibration hose joint, while the pipes and the water pump shall have bracket by themselves to prevent unit from receiving force.
13. Wash and thermal insulation of the system water pipes shall be done before connecting the pipe to the unit.

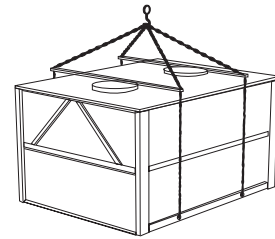

● Safety Precautions

1. The pressure and electric parts of the system will cause danger to the installation and maintenance of the air conditioning equipment, so only the personnel having been trained and with maintenance qualification can perform the installation, operation and maintenance of the air conditioning equipment.
2. Please observe the protection measures and safety warnings marked in the documents, labels and nameplate of the unit.
3. Please observe various safety standards, wearing safety glasses and working gloves, and when welding wear the fireproof clothes.

Warning:

1. Before maintaining the unit, cut off the main power switch of the unit, otherwise electric shock will cause body hurt.
4. When maintaining, only the original parts shall be used and pay attention to correct installation, and the parts must be installed in their previous position.
5. During unit operation, the temperature of some parts of the refrigerant circuit may exceed 70°C , so that the untrained personnel shall not make bold to remove the protection panel of the unit.
6. Unit shall not be installed in the air with explosive gases.
7. If the heat pump type unit operates under the condition below 0°C , it must be installed in a place 300mm higher than the ground, which can not only prevent the chassis of the unit from freezing, but also prevent the accumulated snow is too high to influence the unit's normal operation. The unit shall be installed on a flat surface (the max. deviation of the ground level shall not exceed 2mm/m.)

Unit Installation

● Water System Installation Diagram

Diagram of water pipe connection between three units

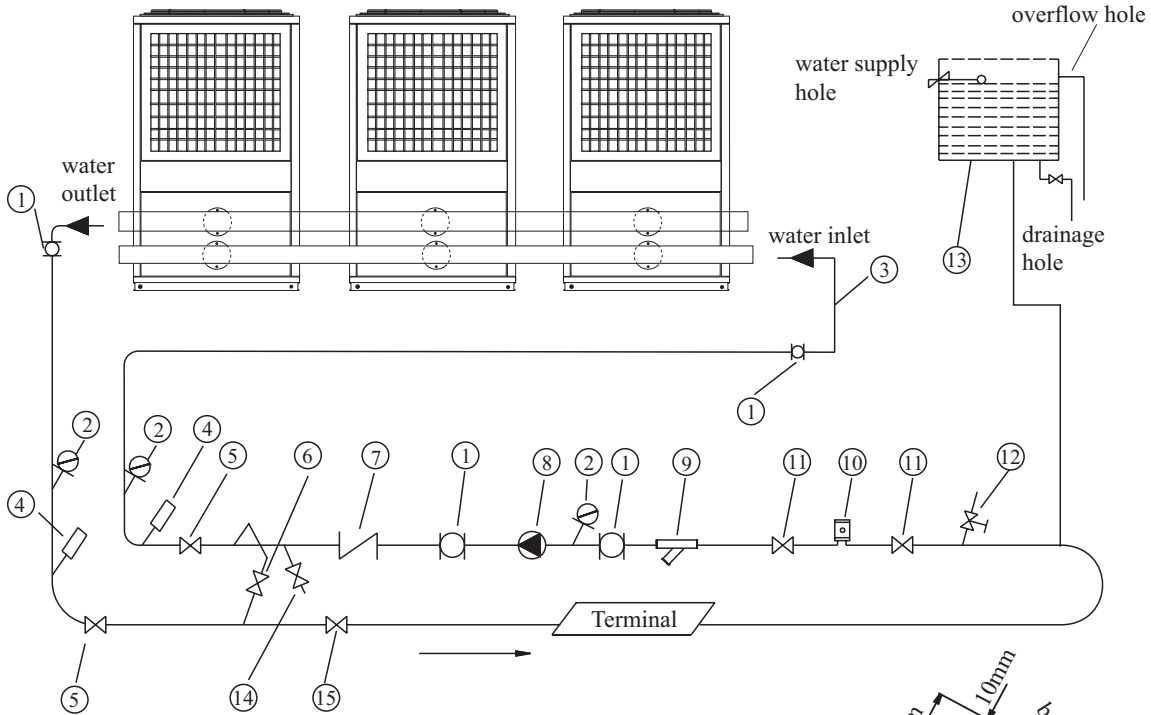

Note:

- | | |
|--|--|
| 1- Flexible hose joint | 2- Pressure gauge |
| 3- Total water return temperature sensor install place
(Ø8, L=60mm, see Diagram A for the structure.) | |
| 4- Thermometer | 5. 11. 15- Stop valve |
| 6- By-pass valve | 7- One-way valve |
| 8- Water Pump | 9- Water strainer |
| 10- electrical water processor | 12- Auto discharging air valve (highest in the water system) |
| 13- Expansion water tank | 14- Drain valve |

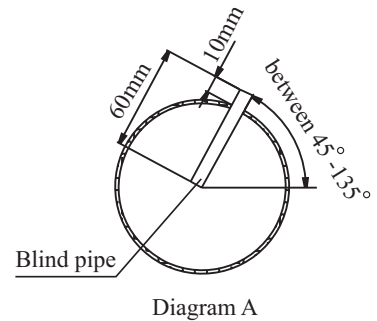

When circulation water runs for the first time, close the inlet and outlet valve (No. 5) and open the by-pass valve (No.6). When water pump works for a while, clean the water filter screen. While ensuring that there is no impurity in the external circulation system, open inlet and outlet valve (No. 5) and close the by-pass valve (No.6). Then, the unit is in normal operation.

Note:

when the installation is over, the total water return temperature sensor in the main module must be fixed on the general water return pipeline. Pay attention that a section of blind pipe (Ø8, L=60mm) be reserved for the installation of temperature sensor during site design and that the insert length of blind pipe is 50mm. When installing the sensor, place the sensor beneath the blind pipe and inject some refrigerant oil into the blind pipe. The level of the refrigeration oil should be at least 10mm over the sensor. To minimize heat transfer error, it is necessary to adopt thermal insulation measures.

Unit Installation

● Typical Wiring and Pipe Connection

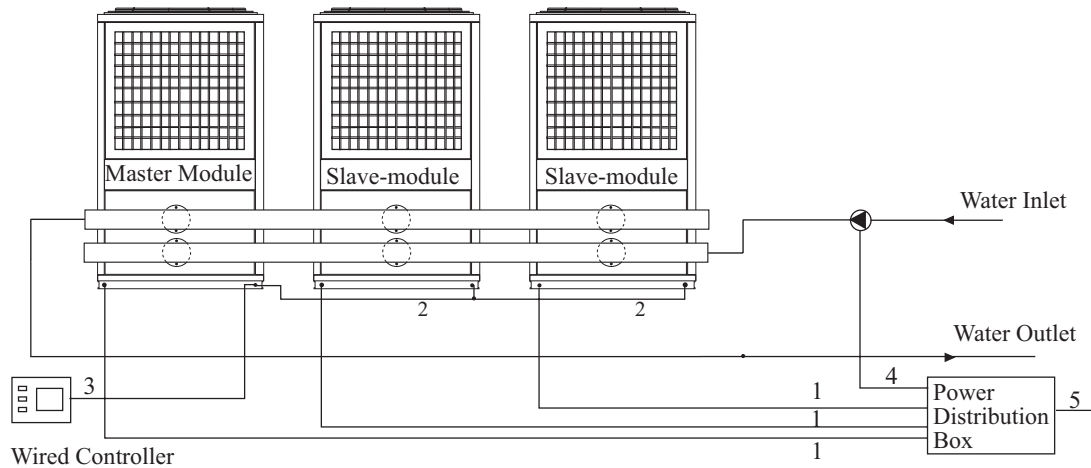

Note:

- | | |
|---|---|
| 1. Unit Power Supply Cord | 4. Water Pump Power Cord |
| 2. Module-based Unit Communication Wire | 5. Cable to Unit Power Distribution Box |
| 3. Unit Operation Controller Wiring | |

Pay attention to the following when in electrical wiring:

1. The unit wiring means the unit power supply cord and communication wire. The control wires in the electrical box for the unit have been connected well in the factory. Users can not be changed.
2. The following table is unit work current. Normal operation of the unit must be ensured during wiring.

Unit Model	Rated Current	Maximum Current	Locked-rotor Current	Reference Cable Sectional Area
CA0100AANB CA0100MANB	52A	67.5A	(130×3)A	5×25mm ²

Unit Installation

Electrical Connection

1. Power Wires Wiring Diagram

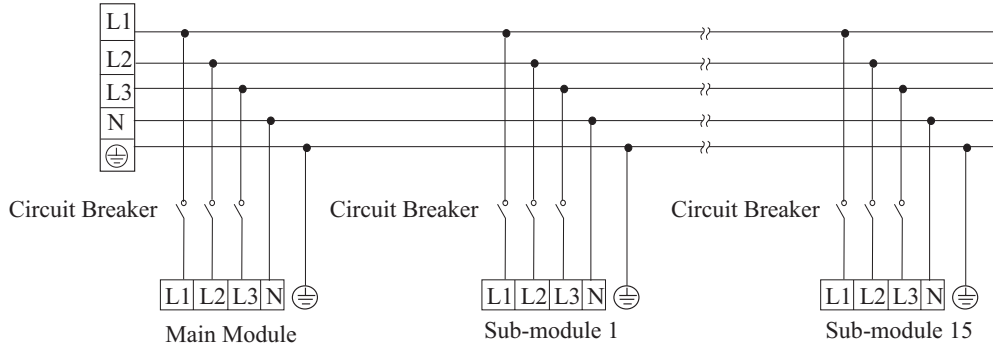

Attention: It should install the fuse between Unit Power and Power Supply when install the module unit.

2. Auxiliary Electrical Heating Control

The electric heater is activated to provide auxiliary heating at lower temperatures. The water inlet and outlet of the auxiliary heater shall be connected in serials with the main outlet pipe of air cooled unit. The electric control box of main module provides a control terminal for auxiliary electric heating (with 200V output signal only). The controls of electric heating should be provided by the user. When the heat pump together with electric heating function is selected, the auxiliary electric heating will be started if the outdoor temperature is lower than that of [SP06] and the selected temperature of heating is 2 degrees above the temperature of return water. When the temperature of return water reaches the selected temperature, the auxiliary electric heating will be turned off.

3. Water Pump Operation Control (effective only when control of water pump and air-conditioner is linked)

Reserve linked control contact for chilling water pump in the electrical control cabinet for air-condition unit. (It only output 220V signal, pump control device is to be supplied by users). The water pump will not start when the unit is in standby mode. When the unit enters work mode from standby mode, the water pump will be started first and will be switched from work mode to standby mode or shut down. After the operation, the water pump will automatically stop after 30 seconds.

Communication connection diagram

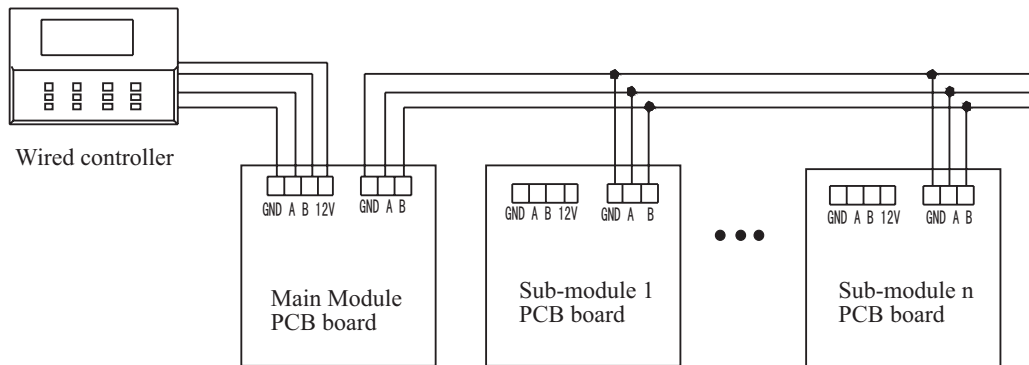



Controller Operation Instruction

● Inspect the air conditioner before it starts.

Necessary inspection and precaution before starting

※Make sure that all electric connection is securely made.

※Make sure that unit is leveled and is supported at the bottom.

※Make sure that water does not leak and valve works well.

※Make sure that flow rate is enough in the water system, connection and installation of pipes are consistent with installation diagram.

※The panel must be installed firmly and safely with screws.

※Make sure that refrigerant does not leak out.

※Make sure that power source is within the range which is specified in the rating plate, circuit diagram and other unit documents as well.

Warning:

The compressor shall be installed on the anti-vibrator, do not loosen or remove the screws of the supporting base.

● Wired controller Operation Instruction

◇ Display screen:
Panel display

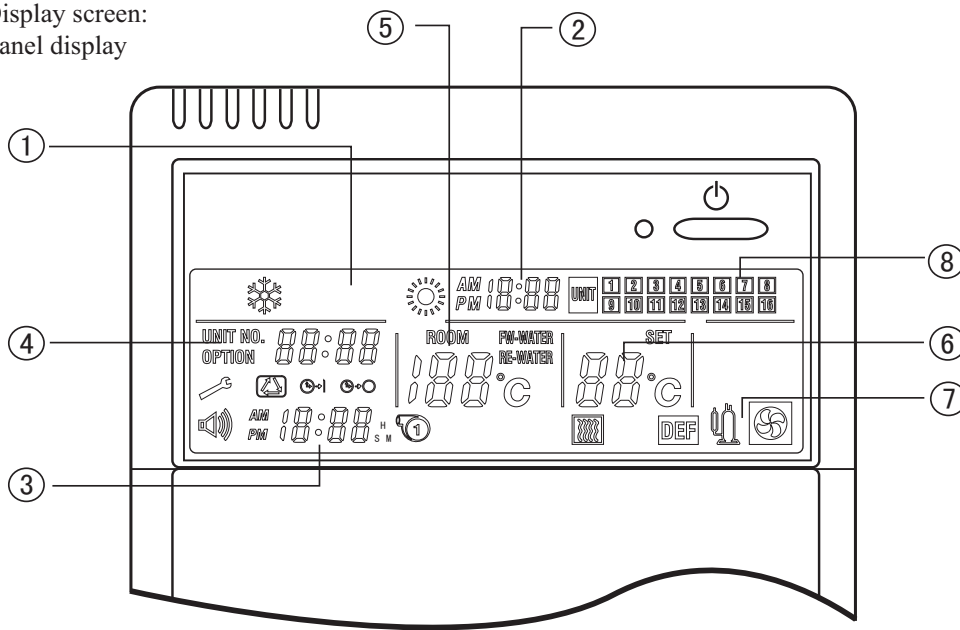

① Mode display

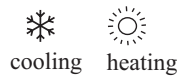

② Clock display

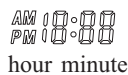

③ Timer setting display

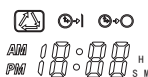

When the appliance is in search or setting mode and time parameter operation, this zone displays mode and time parameter.

④ Code display

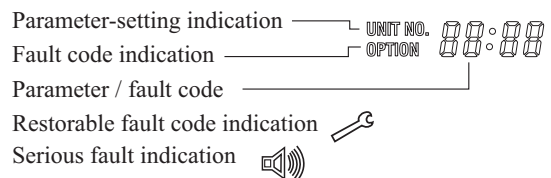

⑤ Temperature display





Controller Operation Instruction

⑥ Temperature setting display

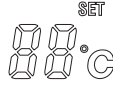

⑦ Output equipment display

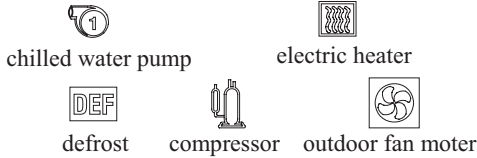

⑧ Unit number displaying zone

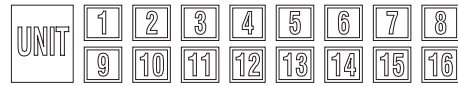

◇ Keypad of wired controller

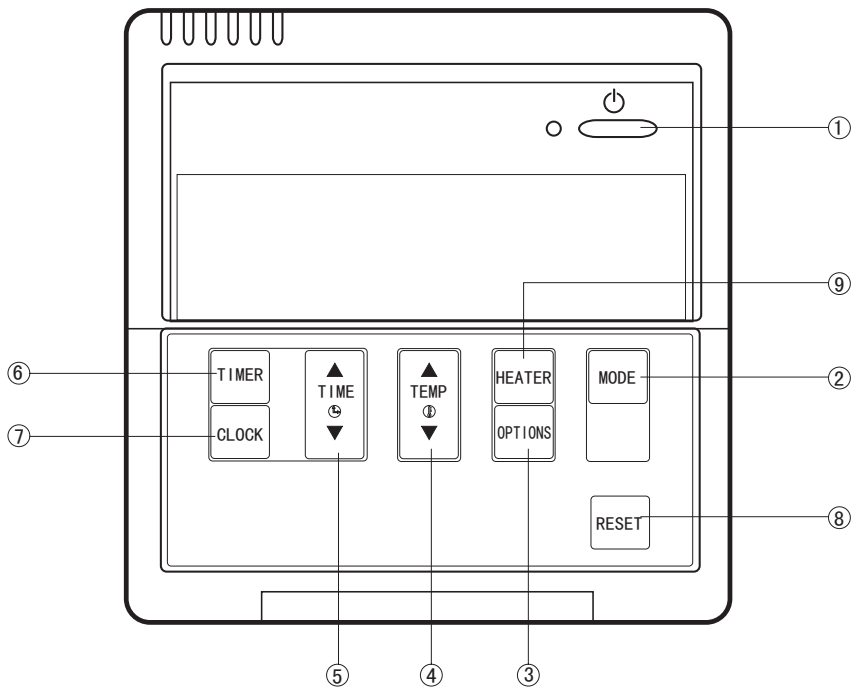

- 1. On/Off key
- 2. mode key
- 3. query key
- 4. temperature “▲▼” key
- 5. time “▲▼” key
- 6. timer key
- 7. clock key
- 8. reset key
- 9. electric heater key

Operation and guidance

There are 11 Touch buttons on the control panel intended for the system parameter input of On/Off operation, mode setting, parameter research, temperature setting, clock setting, time-setting, reset/dark. General layout of all touch buttons is illustrated in the above diagram. Press valid button one time or receive signal from remote control, LCD will display “setting” mode, backlight lightens, the buzzer gives a beep, and backlight is off a 10 seconds later automatically.

Controller Operation Instruction

Control functions

- 1.Working mode: cooling heating
- 2.Working method: return water control style, automatic control work
- 3.Detecting mode: real-time monitoring (restorable fault, serious fault protection): search display (real-time temperature detection)
- 4.Intelligent operation when a sensor fault is present.
- 5.LCD backlight (yellow/green light, blue light, white light)
- 6.Fault alarm
- 7.Remote receiving function (this function must be ordered)
- 8.Restorable fault protection
- 9.Serious fault protection.

Operation instructions of keys

1.Time setting

Press [CLOCK] key into the time setting. Firstly the minute indicator glistens, indicating that you can adjust time by pressing [▲] and [▼] keys. Press time key [▲] one time, the number is increased by 1, press time key [▼] one time, the number is decreased by 1. If pressing time [▲] and [▼] keys for a long time, the number will increase and decrease automatically.

Press [CLOCK] key again in the minute setting mode to enter hour setting mode.

Time adjustment can be cycled by pressing [CLOCK] key. If the controller is not operated within a fixed period of time, it will quit time adjustment automatically.

2.Order of timer setting

Press the [TIMER] key to enter timer setting. The order of timer setting is as follows: on-timer minute-setting, on-timer hour-setting, off-timer minute-setting., off-timer hour-setting, cycling and combination timer setting, cancellation of timer setting.

In the timer setting mode, time [▲] and [▼] keys and can be operated the same as time adjustment.

3.On/Off operation

After the appliance is turned on, red indicator of controller lightens. You can turn it off by pressing [On/Off] key.

After the appliance is turned on, green indicator of controller lightens. You can turn it on by pressing [On/Off] key.

Caution: if the controller is used to set the interlink function of the indoor fan coil and the controller receives no interlink signal, green indicator of controller will lighten when the appliance is working. If serious faults are present, red indicator of controller will lighten.

4.Mode setting.

Press [MODE] key to enter the mode setting. Controller recognizes controller mode automatically. Mode setting cycles between cooling and heating.

5.Temperature-setting

When the appliance is turned on, you can adjust controller to set temperature. Press temperature keys [▲] and [▼], the number of temperature will increase and decrease accordingly. The max and min temperature values are determined by controller.

6.Fault diagnosis

When a fault is present, symbol of “unit” glistens and fault code displays in the fault code displaying zone. Corresponding unit number also glistens at the interval of 2 seconds, press [OPTIONS] key will display fault code in the fault code displaying zone.

If there are several faults, press time key [▲] and [▼], you can see fault codes in turns.



Controller Operation Instruction

7. Temperature search

Press the [OPTIONS] key, you can check temperatures and equipments of all units. Under normal condition, unit number represents the unit that is working. Press the [OPTIONS] key, you can chose unit number that is activated, and the chosen unit number glistens quickly at the intervals of 0.5 second.

When the unit is in search mode, press time key [▲] and [▼], you can see fault code in turn. Press temperature key [▲] and [▼], you can see the temperatures of all units.

When the unit temperature is in search mode, the code of sensor from P01 to P08 is shown on the code displaying zone, temperature displaying zone presents the corresponding temperature. The sensor that is not equipped to the controller will not be displayed.

8. Output equipments status search

When the unit is in search mode, equipment output status will be shown on the controller.

II. Functions descriptions

1. System structure

A. single system

B. Cascade system: integrating an outdoor unit and several indoor units into a centralized controlling system by RS-485 bus. Main-extension cascade system uses one water system; the outdoor unit controls interlinked operation of system pump and other indoor units use the same water system. The outdoor unit harmonizes the work of the system, indoor units working condition is consistent with the outdoor unit. When the working mode of the outdoor unit changes, all indoor units change accordingly. When the outdoor unit is off, all indoor units can't be turned on.

2. Unit number setting

The system is a central air conditioner controlling system consisting of one wired controller and 16 modules numbered from 1 to 16. Every controller panel is assigned with a different address according to the number of system modules used. There is a clip switch which includes 4-digit set on the controlling panel, according to which we can set the module number of unit. After the communication between a module and the wired controller is established, there is one lighting dot representing it on the wired controller.

Diagram of module code number:

Switch 1	Switch 2	Switch 3	Switch 4	Controller No.
OFF	OFF	OFF	OFF	Main Module
OFF	OFF	OFF	ON	Sub-module 1
OFF	OFF	ON	OFF	Sub-module 2
OFF	OFF	ON	ON	Sub-module 3
OFF	ON	OFF	OFF	Sub-module 4
OFF	ON	OFF	ON	Sub-module 5
OFF	ON	ON	OFF	Sub-module 6
OFF	ON	ON	ON	Sub-module 7
ON	OFF	OFF	OFF	Sub-module 8
ON	OFF	OFF	ON	Sub-module 9
ON	OFF	ON	OFF	Sub-module 10
ON	OFF	ON	ON	Sub-module 11
ON	ON	OFF	OFF	Sub-module 12
ON	ON	OFF	ON	Sub-module 13
ON	ON	ON	OFF	Sub-module 14
ON	ON	ON	ON	Sub-module 15

Controller Operation Instruction

3.Type switch

Switch 1	Switch 2	Function name	Function specification
ON	ON	Cooling only	Cooling mode only
OFF	OFF	Heat pump +heater	Cooling, heating, auxiliary heater

Caution: Type must be set according to requirements.

III. Operation modes

Cooling heating (return water control)

IV. Control functions

1.Indoor fan coil interlink function

When setting the indoor fan interlink, control panel detects On/Off mode of the interlink switch at anytime. When one or more indoor fan coils open, interlink switch closes, the system is operates. When all the indoor fan coils close, interlink switch is disconnected for 30s, the system stop working now. When the interlink switch of one indoor fan closes and the indoor fan has been off for at least 3 minutes, the system will restart.

2. Timer On/Off

Timer on, timer off, cycling timer setting and combination timer setting can be chosen through wired controller. Each combination timer setting is valid for within 24 hours and cycling timer setting is valid all the time. The combination timer setting can be selected only when the code [SA09] is set as Off, and the cycling timer setting can be selected only when the code [SA09] is set On.

3. Temperature sensor compensation

In some special cases, if the sensor lead is too long or the installation of indoor fan is limited by installing space, the measured temperature of sensor needs compensation and correction. This function can be achieved by revising code [PC01] and [PC08]. If one code is set as cancelled "---", it means the respective temperature sensor is cancelled. Corresponding function and protection function will be cancelled as well.

4.Unit power-off memory

5.Fault alarm and search

6.Return water temperature, environment temperature and coil pipe temperature display and search.

7.Unit operating code set and reset

8.System clock set and display

9.Compressor operating average energy consumption

The system records the operation time of every compressor separately, those with a shorter operation time will start first when the system starts, and those with a longer time will close first when the system closes.

10.Defrosting options

V. Protection and safety

1.Over-temperature protection for heating operation

When the system is in the process of heating, in order to avoid fault of inner coil pipe due to over-temperature, if the return water temperature is higher than [EP04], over-temperature protection will be activated.

2. Frost-proof in winter

In order to avoid circulated water being frozen in the winter, controller will protect the system according to code [EP07]. Controller has 2-level frost-proof protection, the Level 1 protection starts the circulating pump, auxiliary electric heating at a fixed intervals. The Level 2 protection starts the heating system of compressor to heat the circulated water.

Controller Operation Instruction

3.Flow protection switch

When the flow rate in the pipe is too low, the switch cuts off controlling return route to close the unit, so the unit and compressor are protected.

4.Overload protection of compressor

There is one crankcase-heater and one thermal overload relay equipped to the compressor. Crankcase-heater can preheat the lubrication oil to make sure that the compressor is adequately lubricated. Thermal overload relay can prevent damage of compressor due to overload.

VI. Parameter-setting display and parameter-setting

1. Parameter display

When the appliance is operating or in stand-by mode, press [OPTIONS] key to search the temperatures of outdoor and indoor systems and press “increase” or “decrease” key to select the desired temperatures.

No.	Parameter code	Code number
1	P01	general return water temperature of the system
2	P02	Liquid pipe of 1# system
3	P03	Liquid pipe of 2# system
4	P04	Liquid pipe of 3# system
5	P05	Outdoor temperature
6	P06	1# coil pipe temperature
7	P07	2# coil pipe temperature
8	P08	3# coil pipe temperature

2. Parameter-setting method

When the appliance is off, pressing [OPTIONS] key for 5 seconds until the wired controller gives a beep then let it go to enter code-setting operation.

(1) System function option

Parameter name	Unit number	Original setup	ON	OFF
Defrost option	SA04	OFF	Defrosting during compressor operation	Defrosting at intervals of compressor operation
Mode option	SA07	OFF	Operating mode can be changed when the appliance is in stand-by mode or in operating mode	Operating mode can not be changed when the appliance is in operating mode
Power-failure compensation	SA08	OFF	Controller remains the original mode set after the power supply is restored.	Controller remains off after the power supply is restored.
Combination and cycling timer setting option	SA09	ON	Cycling timer setting (cycling every 24 hours)	Combination timer setting (timer-setting is valid for 24 hours)
Interlink function	SA10	OFF	Terminal interlink is allowed	Terminal interlink is not allowed

(2)Temperature sensor compensation parameter

Parameter name	Unit number	Original setup	min	max	cancellation
General return water temperature	PC01	0 °C	-9 °C	9 °C	
1# liquid pipe temperature	PC02	0 °C	-9 °C	9 °C	--
2# liquid pipe temperature	PC03	0 °C	-9 °C	9 °C	--
3# liquid pipe temperature	PC04	0 °C	-9 °C	9 °C	--
Outside environment temperature	PC05	0 °C	-9 °C	9 °C	--
1# external pipe temperature	PC06	0 °C	-9 °C	9 °C	--
2# external pipe temperature	PC07	0 °C	-9 °C	9 °C	--
3# external pipe temperature	PC08	0 °C	-9 °C	9 °C	--

Controller Operation Instruction

(3) System operating temperature parameter

Parameter name	Unit number	Original setup	Max	Min	cancellation
Loading return difference temperature	SP01	2℃	10℃	1℃	
Unloading return difference temperature	SP02	2℃	10℃	1℃	
Electric-heating initiating return water temperature	SP03	50℃	70℃	20℃	
Cooling external circuit temperature	SP05	15℃	50℃	0℃	
Heating external circuit temperature	SP06	25℃	50℃	0℃	

(4) System operating time parameter

Parameter name	Unit number	Original setup	Max	Min	Cancellation
Interval between temperature detections	SC01	10sec	120sec	1sec	
Interval between start-ups	SC02	30 sec	120sec	5sec	
Interval between stops	SC03	30 sec	120sec	5sec	
Pre-start time of outdoor fan	SC04	10 sec	60sec	1sec	
Delayed stop time of outdoor fan	SC05	5 sec	60sec	1sec	
Backlight illumination time	SC06	10sec	60sec	3sec	--
LCD illumination time during parameter searching	SC07	10sec	30sec	3sec	

(5) Protection temperature parameter

Name	Unit number	Original setup	Max	Min	Cancellation
Cooling and frost-proof protection	EP01	6℃	10℃	-5℃	--
Heating and over-temperature protection	EP04	60℃	80℃	55℃	--
Winter frost-proof protection	EP07	3℃	8℃	-2℃	

(6) Protection time parameter

Name	Unit number	Original setup	Max	Min	Cancellation
Time of compressor startup protection	EC01	3min	10 min	1 min	
Time of compressor operating	EC02	3min	10 min	1 min	
Time of shielded low-side pressure inspection	EC05	30sec	120 sec	0 sec	
Protection duration	EC06	3sec	10 sec	1 sec	
Time of flow switch inspection	EC07	10sec	60 sec	1 sec	

(7) Defrost parameter

Name	Unit number	Original setup	max	min	Cancellation
Defrosting activating external circuit temperature	HF01	8℃	20℃	0℃	
Defrosting activating external and external pipe conditions	HF02	8℃	20℃	1℃	
Defrosting activating external pipe temperature	HF03	-8℃	0℃	-19℃	
Defrosting deactivating external pipe temperature	HF04	10℃	20℃	0℃	
Defrosting activating time condition (cumulative)	HF05	45min	90min	20min	
Defrosting deactivating time condition	HF06	8min	15min	2min	

Caution: The factory settings should not be changed without authorization. The manufacturer will not be responsible for any damages caused thereof.

Controller Operation Instruction

VII. Fault alarm and search

1. Fault parameter display and search

No.	Description	Fault code	Solution	Remarks
1	Transmission error	Eo : 00	Unit stops	Serious fault
2	Open/short circuit of general return water	Eo : 01	Unit stops	Serious fault
3	Main module phase sequence protection	Eo : 03	Unit stops	Serious fault
4	Main module flow protection	Eo : 04	Unit stops	Serious fault
5	1#compressor overload protection	Er: 01	1#compressor stops	Serious fault
6	2#compressor overload protection	Er: 02	2#compressor stops	Serious fault
7	3#compressor overload protection	Er: 03	3#compressor stops	Serious fault
8	1#system high pressure protection	Er: 04	System 1 stops	Serious fault
9	2#system high pressure protection	Er: 05	System 2 stops	Serious fault
10	3#system high pressure protection	Er: 06	System 3 stops	Serious fault
11	Secondary module flow protection	Er: 07	Secondary module stops	Serious fault
12	1#system low pressure protection	Er: 11	System 1 stops	Serious fault
13	2#system low pressure protection	Er: 12	System 2 stops	Serious fault
14	3#system low pressure protection	Er: 13	System 3 stops	Serious fault
15	Open/short circuit of temperature-sensing circuit of liquid pipe 1	Er: 14	System 1 stops	Serious fault
16	Open/short circuit of temperature-sensing circuit of liquid pipe 2	Er: 15	System 2 stops	Serious fault
17	Open/short circuit of temperature-sensing circuit of liquid pipe 3	Er: 16	System 3 stops	Serious fault
18	Outdoor fan overload protection	Er: 17	Unit stops	Serious fault
19	Secondary module phase sequence protection	Er: 18	Secondary module stops	Serious fault
20	Open/short circuit of temperature-sensing circuit of coil pipe 1	Pr: 01	Defrosting without inspection	Restorable
21	Open/short circuit of temperature-sensing circuit of coil pipe 2	Pr: 02	Defrosting without inspection	Restorable
22	Open/short circuit of temperature-sensing circuit of coil pipe 3	Pr: 03	Defrosting without inspection	Restorable
23	Cooling and frost-proof protection of 1 # system	Pr: 04	Protective operating (no maintenance needed)	Restorable
24	Cooling and frost-proof protection of 2 # system	Pr: 05	Protective operating (no maintenance needed)	Restorable
25	Cooling and frost-proof protection of 3 # system	Pr: 06	Protective operating (no maintenance needed)	Restorable
26	Open/short circuit of external circuit temperature-sensing circuit	Po: 01	Defrosting without inspection	Restorable
27	Frost-proof protection in winter	Po: 06	Protective operating (no maintenance needed)	Restorable

(2) When a fault is present, controller gives an alarm and fault module number glitters. Pressing the search key now can show the fault code and the fault can be resolved automatically.

(3) After the fault is resolved, the indication of a serious fault will still display, only after pressing the “reset/dark” key will the system return to operating condition before the fault occurred. As for restorable faults, such as temperature sensor fault, when the fault is resolved, the unit restores automatically.

Instructions of electric connection

● Instructions of electric connection

Before the circuit connection, the following safety rules and measures must be strictly obeyed.

1. When the unit is installed, the electric parts must be installed by professional personnel, the user is not allowed to dismantle and add controlling components. Haier will not be responsible for any unit damages and person injuries caused by not obeying the safety rules.
2. Please refer to circuit diagram when the circuit is connected, circuit diagram is placed in the control box. The cables for communication must be shielded and protected by means of single-end earthing. Wiring of communication cables together with power cables is prohibited.
3. Make sure that the power source for the main power cord is up to the requirement. The voltage must be the same as the requirement on the rating plate.
4. Check if the power source for the main power cord and the wiring before the unit is started. Check if the interlock devices of the water switch and the water pump are securely connected.

● Inspection before operation

1. Voltage is consistent with requirement; phase voltage and phase current are balanced.
2. Inspecting the power source connection, especially section of the power cord, earthing and connecting terminal.
3. Water pipe must keep clean without impurities. At last, flush the pipe 2 or 3 times (bypassing the system), make sure that all the impurities and oxides have been washed out.
4. make sure that water source has been connected properly, if the water pump is not subject to interlock control, start water pump before starting the unit.
5. Check if the water circulating system works well, water system has enough water, and make sure that there is no leakage and air bubbles.

● Inspection of operation status

Please inspect the items as follows:

1. Temperature of water entering into the heat exchanger
2. Temperature of water returning from the heat exchanger
3. Flow rate at the exit of the heat exchanger
4. Operating current of compressor upon start-up or during stable operation
5. Operating current of fan upon start-up or during stable operation

When the appliance is in cooling process, please use a built-in spindle valve to inspect the saturated temperature (related to pressure) in the working mode

Referring to the requirements as follows:

1. High pressure side: saturated temperature is about 15-18°C higher than the temperature at the inlet of condenser.
2. Low pressure side: saturated temperature is about 5-7°C lower than temperature at the outlet of condenser.
3. When the appliance is the heating process, the water temperature should not be high than 50°C.

● Operating range:

Cooling	Min	Max
Outdoor temperature	+25°C	+50°C
Water temperature at outlet	+7°C	+15°C

Heating	Min	Max
Outdoor temperature	-10°C	+25°C
Water temperature at outlet	+25°C	+55°C

Maintenance & Service

Maintenance

Note: Before performing any maintenance and repair to the unit, please cut off power supply. Electricity leakage will cause body injury.

In order to exert the unit's performance fully, must pay attention to the following items:

1. Electrical Connection: Shielded wire should be adopted as communication wire and the single end of shielding layer should be grounded. It is prohibited to do the wiring of commutation wire and power wire together. Power supply should be within the range allowable for compressor. Ensure there is no wrong wiring at wiring terminals and AC contactor mainboard. Ensure that there is loose electrical connection. All the electrical components (AC contactor and relay) are securely connected. Pay special attention to the connection between control components and electrical control box and make sure there is no bent electrical wire and no cracked insulation layer. Check and ensure that start and operation energy consumption are within the permitted range.

2. Water System Connection: confirm the water system does not leak water. If the unit will stop to use for a long period of time, it is necessary to open the drain valve of the water pump to empty the water pump, sleeve pipe or shell pipe type heat exchanger and all the water in the pipes. If the ambient temperature may drop below 0°C, it is more necessary to be done.

If the water in the unit is not emptied, the main switch of the power supply must keep close, and the unit is set in heating mode, thus it can prevent from freezing by the heating temperature sensor. Do be careful when cleaning the filter.

3. Cleaning of tube in tube type (or shell type) heat exchanger: when using the unit, for example, when using hard water, sometimes it will produce scale. In this condition, it is recommended to install the filter to remove scale. The heat exchanger shall use cleaning solution to wash, the solution can be weak acid solution, use pump to drive the cleaning solution in the heat exchanger.

The installation of the liquid container for weak acid solution can be permanent or as an optional device. If there is spare connecting pipe, the portable cleaning device can be installed in the pipes at any time.

In order to fulfill a better cleaning effect, the circulation flow speed of the acid solution shall be 1.5 times of normal water flow, if can use acid solution to wash the pipe in an opposite direction again, the effect will be better. Finally, use a large amount of water to repeatedly wash the acid solution clean.

The unit shall be cleaned periodically, not until the unit is blocked. The cleaning frequency is determined by the water quality being used, but generally, once a year is rather reasonable.

4. Refrigerant Circuit: Confirm the refrigerant and refrigerant oil does not leak from the compressor. Check if the pressure in the high/low pressure side is normal. Check the inside cleanness of the plate type heat exchanger by pressure drop.

5. Control: Check the position of general water return temperature sensor and heat transfer temperature difference and make correction accordingly. Check the operation of all the relays and check high voltage and low voltage protection and control.

Service

1. Before changing any parts of the refrigerant circuit, confirm all the charged refrigerant have been emptied from the high/low pressure side of the unit. The control components' sensitivity of the cooling system is very high, if needing change, it must be very careful, do not make the components overheat when welding, so when welding, use wet cloth to wrap the components, and the flame shall not directly face the components.

2. If needing to replace the refrigerant of the unit, its quantity shall be in accordance with the data on the nameplate. Before replacing, the previous gas must be released as empty as possible.

3. During unit running, all the panels must be installed properly, including the panel on the control box.

4. If it must cut the pipes of the refrigerant circuit, the pipe cutter must be used, do not use the tools that will produce copper scraps. All the pipes of the refrigerant circuit are copper pipes special for cooling.

Final Instruction

The unit you bought had passed strict quality control before it left factory.

The user shall operate all the units strictly according to this manual, for any damages caused by wrong operation, the manufacturer has no responsibility.

