

# CONVERTIBLE CEILING/FLOOR MOUNTING & EXPOSED CEILING/FLOOR MOUNTING AIR CONDITIONER

## Operation & Installation Manual

HCFU-18CF03

HCFU-18HF03

HCFU-28CF03

HCFU-28HF03

No. 0010576835

- Please read this operation manual before using the air conditioner.
- Please keep this manual carefully and safely.

# ■ Contents

---

Cautions .....	1-2
Safety Precautions .....	3
Features and Functions .....	4
Name of Parts .....	5
Cleaning and Care .....	6-7
Trouble Shooting.....	8-9
Operation Tips .....	10
Installation of Indoor Unit .....	11-23

# ■ Cautions

---

## *Disposal of the old air conditioner*

Before disposing an old air conditioner that goes out of use, please make sure it's inoperative and safe. Unplug the air conditioner in order to avoid the risk of child entrapment.

It must be noticed that air conditioner system contains refrigerants, which require specialized waste disposal. The valuable materials contained in a air conditioner can be recycled. Contact your local waste disposal center for proper disposal of an old air conditioner and contact your local authority or your dealer if you have any question. Please ensure that the pipework of your air conditioner does not get damaged prior to being picked up by the relevant waste disposal center, and contribute to environmental awareness by insisting on an appropriate, anti-pollution method of disposal.

## *Disposal of the packaging of your new air conditioner*

All the packaging materials employed in the package of your new air conditioner may be disposed without any danger to the environment.

The cardboard box may be broken or cut into smaller pieces and given to a waste paper disposal service. The wrapping bag made of polyethylene and the polyethylene foam pads contain no fluorochloric hydrocarbon.

All these valuable materials may be taken to a waste collecting center and used again after adequate recycling.

Consult your local authorities for the name and address of the waste materials collecting centers and waste paper disposal services nearest to your house.

## *Safety Instructions and Warnings*

Before starting the air conditioner, read the information given in the User's Guide carefully. The User's Guide contains very important observations relating to the assembly, operation and maintenance of the air conditioner.

The manufacturer does not accept responsibility for any damages that may arise due to non-observation of the following instruction.

- Damaged air conditioners are not to be put into operation. In case of doubt, consult your supplier.
- Use of the air conditioner is to be carried out in strict compliance with the relative instructions set forth in the User's Guide.
- Installation shall be done by professional people, don't install unit by yourself.

# ■ Cautions

---

- For the purpose of safety, the air conditioner must be properly grounded in accordance with specifications.
- Always remember to unplug the air conditioner before opening inlet grill. Never unplug your air conditioner by pulling on the power cord. Always grip plug firmly and pull straight out from the outlet.
- All electrical repairs must be carried out by qualified electricians. Inadequate repairs may result in a major source of danger for the user of the air conditioner.
- Do not damage any parts of the air conditioner that carry refrigerant by piercing or perforating the air conditioner's tubes with sharp or pointed items, crushing or twisting any tubes, or scraping the coatings off the surfaces. If the refrigerant spurts out and gets into eyes, it may result in serious eye injuries.
- Do not obstruct or cover the ventilation grille of the air conditioner. Do not put fingers or any other things into the inlet/outlet and swing louver.
- Do not allow children to play with the air conditioner. In no case should children be allowed to sit on the outdoor unit.

# ■ Safety Precautions

---

## **⚠ WARNING!**

- If the power supply cord of this air conditioner is damaged, it must be replaced by the manufacturer its authorized service personnel only.
- The breaker of the air conditioner should be all-pole switch; and the distance between its two contacts should be no less 3mm. Such means for disconnection must be incorporation in the fixed wiring.
- Use copper wire only. All the cables shall have got the local certificate.
- For series 18, the power supply connects from the indoor side.  
For series 28, the power supply connects from the outdoor side. The power cable and connecting cable are self-provided.
- The parameter of connecting cable:  
HCFU-18CF03:H05RN-F 3G\*2.0mm<sup>2</sup>, HCFU-18HF03: 3G\*2.0mm<sup>2</sup>+2\*0.75mm<sup>2</sup>,  
HCFU-28CF03:H05RN-F 4G\*0.75mm<sup>2</sup>, HCFU-18HF03:6G\*0.75mm<sup>2</sup>,
- The parameter of the power supply cord:  
For series 18, H05RN-F 3G 2.5mm<sup>2</sup> .  
For series 28, H05RN-F 3G 4.0mm<sup>2</sup>.

## **⚠ DANGER!**

- Do not attempt to install this air conditioner by yourself.
- This unit contains no user-serviceable parts. Always consult authorized service personnel for repairs.
- When moving, consult authorized service personnel for disconnection and installation of the unit.
- Do not become excessively chilled by staying for lengthy periods in the direct cooling airflow.
- Do not insert fingers or objects into the outlet port or intake grills.
- Do not start and stop air conditioner operation by connecting and disconnecting the power supply cord and so on.
- Take care not to damage the power supply cord.
- In the event of a malfunction (burning smell, etc.), stop operation immediately, turn off the circuit breaker, and consult authorized service personnel.

## **⚠ CAUTION!**

- Provide occasional ventilation during use.
- Do not direct air flow at fireplaces or heating apparatuses.
- Do not climb on place objects on the air conditioner.
- Do not hang objects from the indoor unit.
- Do not set flower vases or water containers on top of the air conditioner.
- Do not expose the air conditioner directly to water.
- Do not operate the air conditioner with wet hands.
- Do not pull power supply cord.
- Turn off power source when not using the unit for extended periods.
- Check the condition of the installation stand for damage.
- Do not place animals or plants in the direct path of the air flow.
- Do not drink the water drained from the air conditioner.
- Do not use in applications involving the storage of foods, plants or animals, precision equipment, or art works.
- Do not apply any heavy pressure to radiator fins.
- Operate only with air filters installed.
- Do not block or cover the intake grill and outlet port.
- Ensure that any electronic equipment is at least one metre away from either the indoor or outdoor unit.
- Avoid installing the air conditioner near a fireplace or other heating apparatuses.
- When installing the indoor and outdoor unit, take precautions to prevent access to infants.
- Do not use inflammable gases near the air conditioner.

# ■ Features and Functions

---

## AUTOMATIC OPERATION

- **COOLING TYPE**

Merely press the ON/OFF button, and the unit will begin automatic operation in the Cooling or dry modes as appropriate, in accordance with the thermostat setting and the actual temperature of the room.

- **HEAT & COOL TYPE**

Merely press the ON/OFF button, and the unit will begin automatic operation in any of the Heating, Cooling and Blow modes as appropriate, in accordance with the thermostat setting and the actual temperature of the room.

## SLEEP

- **COOLING TYPE**

When the SLEEP button is pressed during Cooling or Dry mode, the thermostat setting gradually rises during the period of operation. When the set time is reached, the unit automatically turns off.

- **HEAT & COOL TYPE**

When the SLEEP button is pressed during Heating mode, the air conditioner's thermostat setting gradually lowers during the period of operation; When the set time is reached, the unit automatically turns off.

## WIRELESS REMOTE CONTROL UNIT

- The WIRELESS REMOTE CONTROL UNIT allows convenient control of air conditioner operation.

# ■ Name of Parts

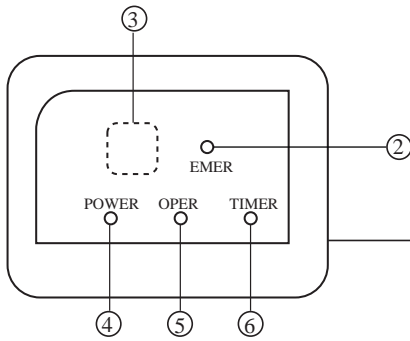
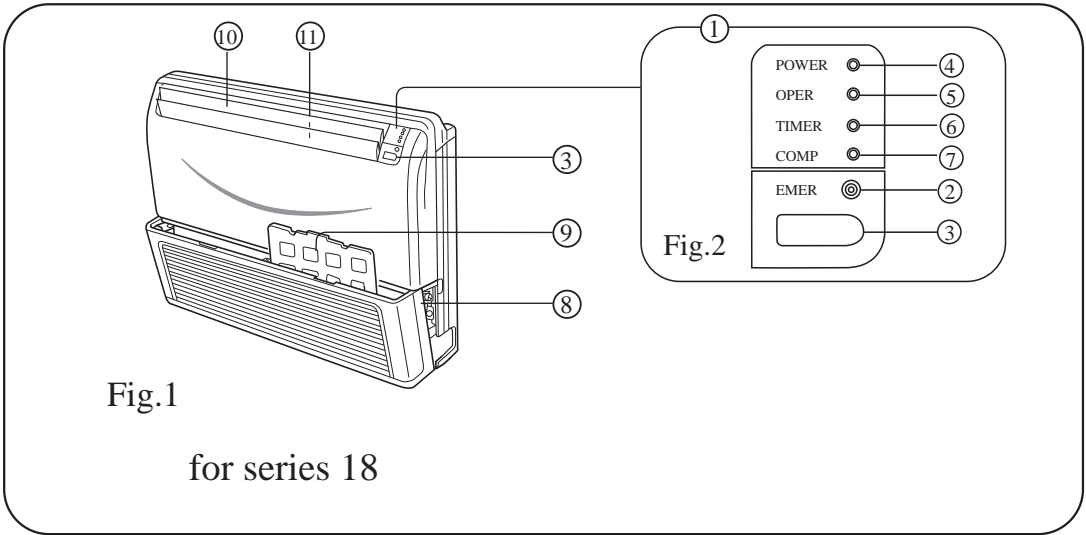
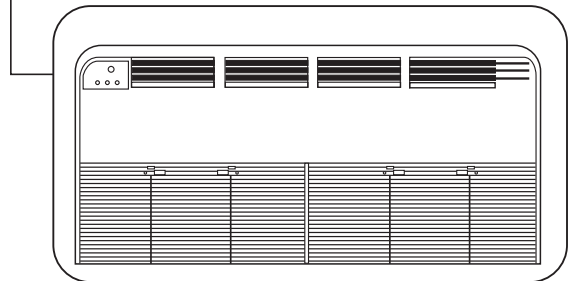

Fig.1 Indoor Unit

- ① Operating Control Panel (Fig.2)
- ② Emergency switch
- ③ Remote Control Signal Receiver
- ④ Power Indicator Lamp
- ⑤ OPERATION Indicator Lamp
- ⑥ TIMER Indicator Lamp
- ⑦ Compressor Run Lamp
- ⑧ Intake Grill (Fig.3)
- ⑨ Air Filter
- ⑩ UP/DOWN Air Direction Flaps
- ⑪ RIGHT/LEFT Air Direction Louvers  
(behind UP/DOWN Air Direction Flaps)



for series 28

# Cleaning and Care

## ⚠ CAUTION!

- Before cleaning the air conditioner, be sure to turn it off and disconnect the Power Supply Cord.
- Be sure the Intake Grill is installed securely.
- When removing and replacing the air filters, be sure not to touch the heat exchanger, as personal injury may result.

### Cleaning the Air Filter

(For Series 18)

#### Open the Intake Grill

1. Pull out both sides and the center of the Intake Grill.

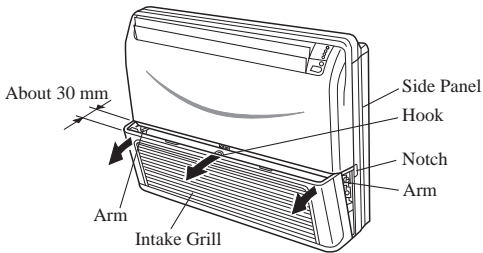

2. Pull the Air Filters upward to remove them.

Push the Air Filter handles away from the Intake Grille in direction as illustrated, then pull out Air Filters.

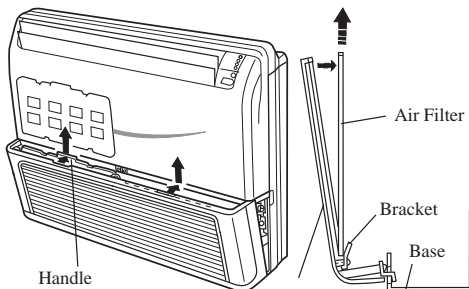

3. Clean the Air Filters.

Remove the dust from the Air Filters by vacuum cleaner or washing them. After washing, allow the Air Filters to dry thoroughly in an area protected from sunlight.

#### 4. Re-attach the Air Filters to the Intake Grill.

- ① The Filters fit onto the inside of the intake Grill. (figure 1)
- ② The bottom edges of the Air Filters should fit into the filter brackets. (figure 1)
- ③ The Air Filters should be pushed down so that their top edges fit under the projections at the top of the Intake Grill. (figure 2)

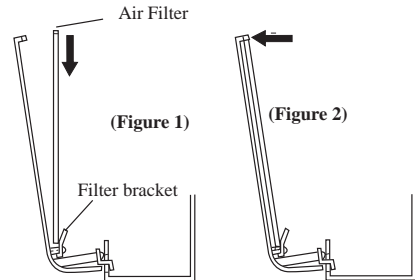

5. Push in both sides and the center of the Intake Grill.

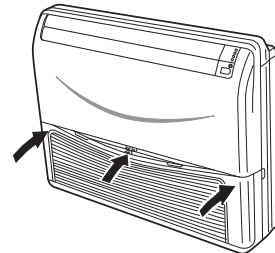

- Dust can be cleaned from the Air Filter either with a vacuum cleaner, or by washing the filter in a solution of mild detergent and warm water. If you wash the filter, be sure to allow it to dry thoroughly in a shady place before reinstalling.
- If dirt is allowed to accumulate on the Air Filter, air flow will be reduced, lowering operating efficiency and increasing noise.
- During periods of normal use, the Air Filters should be cleaned every two weeks.



# ■ Cleaning and Care

## **⚠ CAUTION!**

- Before cleaning the air conditioner, be sure to turn it off and disconnect the Power Supply Cord.
- Be sure the Intake Grill is installed securely.
- When removing and replacing the air filters, be sure not to touch the heat exchanger, as personal injury may result.

The following four procedures are for series 28.

**1. Press the two buttons on the filters, until you hear a sound of click.**

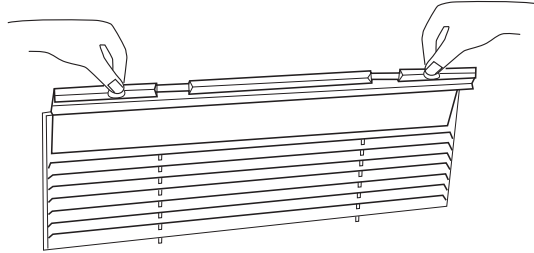

**2. Pull the filters upward to remove them from the Intake Grill.**

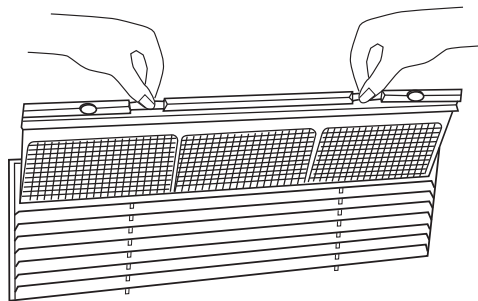





**3. Clean the air filter: Remove the dust from the filters by vacuum cleaner or washing them. After washing, allow the air filters to dry thoroughly in an area protected from sunlight.**

**4. Re-attach the air filters to the Intake Grill, press the two buttons on the filters, until you hear a sound of click.**

- When used for extended periods, the unit may accumulate dirt inside, which reduces its performance. We recommend that the unit is inspected regularly, in addition to your own cleaning and care. For more information, consult authorized service personnel.
- When cleaning the unit's body, do not use water hotter than 40\*, harsh abrasive cleansers, or volatile agents like benzene or thinner.
- Do not expose the unit body to liquid insecticides or hairsprays.
- When shutting down the unit for one month or more, first allow the Fan mode to operate continuously for about half a day to allow internal parts to dry thoroughly.









# ■ Trouble Shooting

## Followings are not problems

<p>Sound of water flowing is not a problem.</p> 	<p>During unit operation or at stop, a swishing or gurgling noise may be heard. This noise is generated by refrigerant flowing in the system.</p>
<p>Sound of cracking is heard.</p>	<p>During unit operation, a cracking noise may be heard. This noise is generated by the casing expanding or shrinking because of temperature changes.</p>
<p>Smell are generated.</p>	<p>This is because the system circulates smells from the interior air such as the smell of cigarettes or the painting on the furniture.</p>
<p>During operation, white fog or steam comes out from the indoor unit.</p>	<p>When unit is running at places like restaurant, etc. where dense edible oil fumes always exist, this will happen.</p>
<p>In cooling operation, unit switches to blowing operation.</p>	<p>To prevent frost from accumulating on indoor heat exchanger, unit will switch to blowing operation for a while then resume cooling operation.</p>
<p>Unit will not restart after stop.</p> <p>Won't start?</p> 	<p>Though ON/OFF button is set to ON, unit won't resume cooling, dry or heating operation in 3 min after it is stopped, this is because of 3-min-delay protection circuit.</p>  <p>Please wait 3 minutes</p>
<p>No outlet air or fan speed can't be changed in dry mode.</p>	<p>Unit will reduce fan speed repeatedly and automatically if room temp. is too low in dry operation.</p>
<p>In heating operation, water or steam are blown out of outdoor unit.</p> 	<p>This occurs when frost accumulated on the outdoor unit is removed. (during defrosting operation)</p> 
<p>In heating operation, indoor fan won't stop even if unit is stopped.</p>	<p>After unit stop, indoor fan will go on running until indoor unit cools down.</p>

# Trouble Shooting

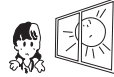
Before ask for services, please first check your unit against the following.

Air conditioner won't start.		
<p>Is power supply switch turned on?</p>  <p>Power supply switch is not set at ON.</p>	<p>Is city power supply normal?</p> 	<p>Is leakage current breaker activated?</p> <p>This is very dangerous, please disconnect power supply immediately and contact your dealer.</p>
Poor cooling or heating		
<p>Are operation control adjusted correctly as specified?</p> 	<p>Is air filter too dirty?</p> 	<p>Are there any obstacles in inlet or outlet grill?</p> 
<p>Are horizontal louvers at up position (in heating mode)?</p>	<p>Any doors or windows left open?</p> 	
Poor cooling		
<p>Is there any direct sunlight in the room?</p> 	<p>If there are unexpected heat sources in the room?</p> 	<p>Too many people in the room?</p> 
<p>Cold air blows out (in heating mode)</p>	<p>If your unit still can't work properly after above mentioned checks, or following problems occur, please stop it immediately and contact your dealer.</p> <ul style="list-style-type: none"> <li>• Fuses or circuit breakers often blow out.</li> <li>• Water comes out in cooling/dry operation.</li> <li>• Operation is abnormal or sound is heard.</li> </ul>	
<p>Is air conditioner in standby condition in heating mode?</p>		

## Error display

Failure description	Flash times of indoor receiver board
Room temp. sensor abnormal	Power LED flashes 1 time
Indoor coil temp. sensor abnormal	Power LED flashes 2 times
Outdoor temp. sensor abnormal	Power LED flashes 3 times
Outdoor coil temp. sensor abnormal	Power LED flashes 4 times
Over-current malfunction	Power LED flashes 5 times
High / Low pressure abnormal	Power LED flashes 16 times
Communication malfunction between indoor and wired controller	Power LED flashes 8 times
Communication malfunction between indoor and outdoor abnormal	Power LED flashes 9 times
Drainage system malfunction	Power LED flashes 10 times
Alarm of exterior annunciator	Power LED flashes 11 times
Coil gas pipe temp. Sensor abnormal	Power LED flashes 12 times
Temperature protection malfunction	Power LED flashes 13 times

# ■ Operation Tips

## Operation and Performance

### \*Heating Performance

- This air conditioner operates on the heat-pump principle, absorbing heat from outdoor air and transferring that heat indoors. As a result, the operating performance is reduced as outdoor air temperature drops. If you feel that insufficient heating performance is being produced, we recommend you use this air conditioner in conjunction with another kind of heating appliance.
- Heat-pump air conditioners heat your entire room by recirculating air throughout the room, with the result that some time may be required after first starting the air conditioner until the room is heated.

Instructions relating to heating (\*) are applicable only to "HEAT & COOL TYPE".

## Temperature and Humidity Range

			Rated	Maximum	Minimum
Cooling	Indoor	DB °C	27	32	18
		WB °C	19	23	14
	outdoor	DB °C	35	43	10
		WB °C	24	26	6
Heating	Indoor	DB °C	20	27	15
		WB °C	14.5	--	--
	outdoor	DB °C	7	24	-7
		WB °C	6	18	--

### \*Microcomputer-controlled Automatic Defrosting

- When using the Heating mode under conditions of low outdoor air temperature high humidity, frost may form on the outdoor unit, resulting in reduced operating performance.
- In order to prevent this kind of reduced performance, this unit is equipped with a Microcomputer-controlled Automatic Defrosting function. If frost forms, the air conditioner will temporarily stop, and the defrosting circuit will operate briefly (for about 7 to 15 minutes).

During Automatic Defrosting operation, the OPERATION Indicator Lamp will flash.

### \*Trouble alarming performance

During operation, when there is any trouble, the power indicator lamp will flash.

- If the air conditioner is used under higher temperature condition than those listed, the built-in protection circuit may operate to prevent internal circuit damage. Also, during Cooling and Dry modes, if the unit is used under conditions of lower temperature than those listed above, the heat-exchanger may freeze, leading to water leakage and other damage.
- Do not use this unit for any other purposes except for the Cooling, (\*) Heating, Dehumidifying, and air-circulation of rooms in ordinary dwellings.
- The wiring method should be in line with the local wiring standard.
- The waste battery should be disposed properly.
- If the fuse on PC board is broken, please change it with the type T 3.15A/250VAC.

# ■ Installation of Indoor Unit

Please ask the dealer or specialist to install, never try by the users themselves. After the installation please be sure of the following conditions.

## WARNING !

- **Please call dealer to install the air-conditioner.**  
Incorrect installation may cause water leaking, shock and fire hazard.

## CAUTION !

- **Air-conditioner can't be installed in the environment with inflammable gases because the inflammable gases near to air-conditioner may cause fire hazard.**
- **Installed electrical-leaking circuit breaker.**  
It easily cause electrical shock without circuit breaker.
- **Connect earthing wire.**  
Earthing wire should not be connected to the gas pipe, water pipe, lightning rod or phone line, incorrect earthing may cause shock.  Earthing
- **Use discharge pipe correctly to ensure efficient discharge.**  
Incorrect pipe use may cause water leaking.

### [Location]

- Air-conditioner should be located in well-vented and easily-accessible place.
- Air-conditioner should not be located in the following places:
  - (a) Places with machine oils or other oil vapours.
  - (b) Seaside with high salt content in the air.
  - (c) Near to hot spring with high content of sulfide gases.
  - (d) Area with frequent fluctuation of voltage e.g. factory, etc.
  - (e) In vehicles or ships.
  - (f) Kitchen with heavy oil vapour or humidity.
  - (g) Near to the machine emitting electric-magnetic waves.
  - (h) Places with acid, alkali vapour.
- TV, radio, acoustic appliances etc are at least 1 m far away to the indoor unit, outdoor unit, power

- supply wire, connecting wire, pipes, otherwise images may be disturbed or noises be created.
- As required, take measures against heavy snow.

### [Wiring]

- Air-conditioner should be equipped with special power supply wire.

### [Operating noise]

- Choose the following locations:
  - (a) Capable of supporting air-conditioner weight, don't increase operating noise and vibration.
  - (b) Hot vapour from outdoor unit outlet and operating noise don't disturb neighbour.
- No obstacles around the outdoor unit outlet.

# ■ Installation of Indoor Unit

For authorized service personnel only

## WARNING

- (1) For the room air conditioner to operate satisfactorily, install it as outlined in this installation manual.
- (2) Connect the indoor unit and outdoor unit with the room air conditioner piping and cords available from our standard parts. This installation manual describes for the correct connections so that the installation set available from our standard parts should be used.
- (3) Installation work must be performed in accordance with national wiring standards by authorized personnel only.
- (4) Never cut the power cord, lengthen or shorten the cord, or change the plug.
- (5) Also, do not use an extension cord.
- (6) Plug in the power cord plug firmly. If the receptacle is loose, repair it before using the room air conditioner.
- (7) Do not turn on the power until all installation work is done.
  - Be careful not to scratch the room air conditioner when handling it.
  - After installation, explain correct operation to the customer, according to the operating manual.
  - Let the customer keep this installation manual because it will be used when the room air conditioner is serviced or moved.

## 1. SELECTING THE MOUNTING POSITION

### WARNING

- Install at a place that can withstand the weight of the indoor units and install positively so that the units will not topple or fall.

### CAUTION

- Do not install where there is the danger of combustible gas leakage.
- Do not install near heat sources.
- If children under 10 years old may approach the unit, take preventive measures so that they cannot reach the unit.

#### **(1) Decide the mounting position with the customer as follows:**

- Install the indoor unit level on a strong wall, floor, ceiling which is not subject to vibration.
- The inlet and outlet ports should not be obstructed: the air should be able to blow all over the room.
- Install the unit near an electric outlet or special branch circuit.
- Do not install the unit where it will be exposed to direct sunlight.
- Install the unit where connection to the outdoor unit is easy.
- Install the unit where the drain pipe can be easily installed.

NOTE: The appearance may be different from models.

# Installation of Indoor Unit

## CONNECTION PIPE REQUIREMENT

Table 1

Model	Diameter		Maximum length	Maximum height (between indoor and outdoor)
	Liquid side	Gas side		
HCFU-18CF03 HCFU-18HF03	6.35 mm	12.7 mm	15 m	5 m
HCFU-28CF03 HCFU-28HF03	9.52 mm	15.88 mm	30 m	20 m

## INSTALLATION PROCEDURE

Install the room air conditioner as follows:

### PREPARING INDOOR UNIT INSTALLATION

#### 1. REMOVE THE INTAKE GRILL

Open the intake grill and remove the three or four or six screws.(Fig. 1)

**Remark: The main unit can be wired before the indoor unit is installed. Select the most appropriate installation order.**

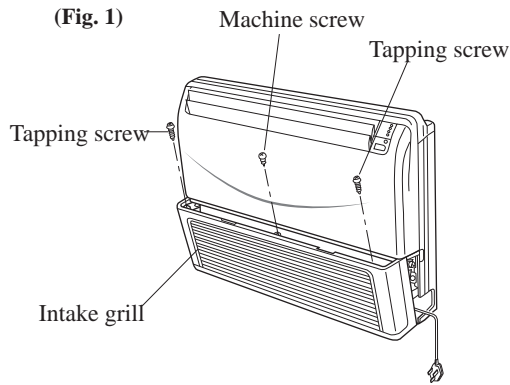

For series 28, there is no power plug.

#### A. FLOOR CONSOLE TYPE

##### 1. DRILLING FOR PIPING

Select piping and drain directions.(Fig.2)

The piping and drain can be made in three directions as shown below.

(Fig. 2)

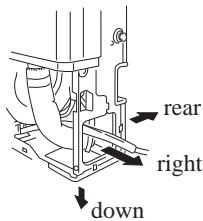

The drain hose can be connected to either the left or right side.(Fig.3) For series 28 only right side.

(Fig.3)

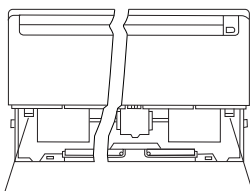

Drain hose (Left side)

Drain hose (Right side)

When the directions are selected, drill a 7 cm dia. hole on the wall so that the hole is tilted downward toward the outdoor for smooth water flow. When the pipe is led out from the rear, make a hole in Fig.6, at the position shown.

# Installation of Indoor Unit

(Fig. 4)

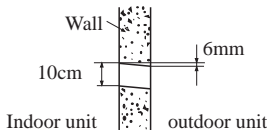

When installing set to wall, install the accessory wall bracket at the position shown in Fig.5, and mount the set to it.

(Fig. 5)

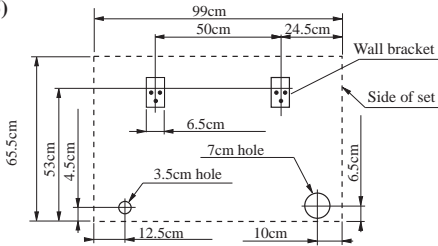

For series 18

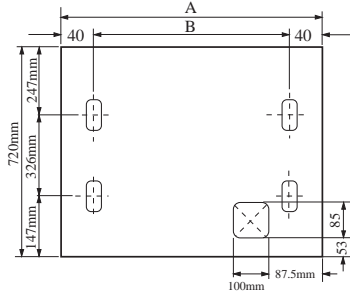

Series	A	B
28	1320	1240

## 2. INSTALLING DRAIN HOSE

Select whether the drain hose will be connected to the left or right side. (for series 28 only the right side). (Fig.3) Insert the drain hose into the drain pan, then secure the drain hose with a nylon fastener. (Fig.6)

(Fig. 6)

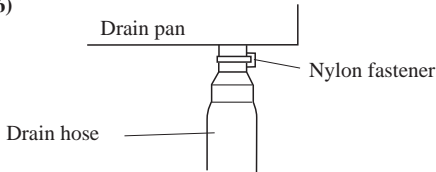

(Fig. 7)

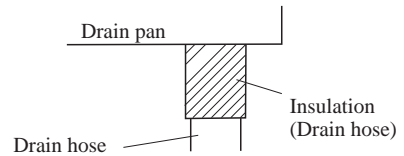

Wrap the insulation (drain hose) around the drain hose connection. (Fig.7)

Be sure to arrange the drain hose correctly so that it is leveled lower than the drain hose connecting port of the indoor unit.

(Fig. 8)

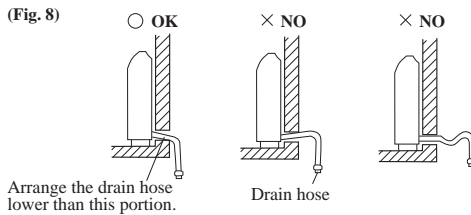

Arrange the drain hose lower than this portion.

Drain hose

### ⚠ CAUTION

Do not install the unit drain hose side is too high. Height A should be less than 5 mm. (Fig.9)

(Fig. 9)

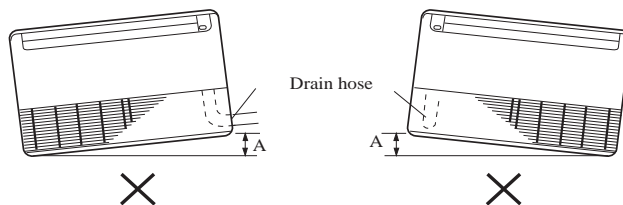



# Installation of Indoor Unit

## B. UNDER CEILING TYPE

Using the installation template, drill holes for piping and anchor bolts(for holes).(Fig.10)

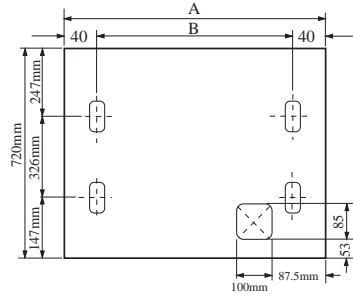
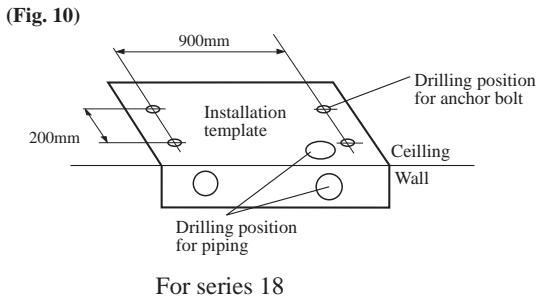

Series	A	B
28	1320	1240

## 1. DRILLING FOR PIPING

Select piping and drain directions. For series 28, only rear side (Fig.11)

(Fig. 11)

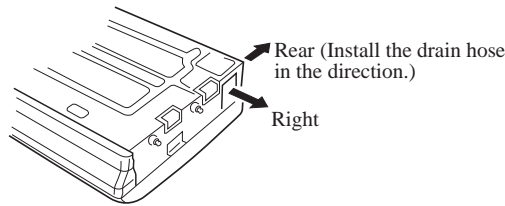

### ⚠ CAUTION

**Install the drain hose at the rear; it should not be installed on the top or right side.**

## 2. DRILLING HOLES FOR ANCHOR BOLTS AND INSTALLING THE ANCHOR BOLTS

When the directions are selected, drill 80mm and 50mm or 150mm dia. hole on the wall so that the hole is tilted downward toward the outdoor for smooth water flow.

(Fig. 12)

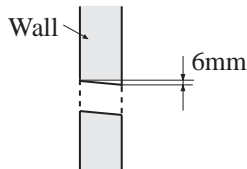

With a concrete drill, drill four 12.7 mm dia. Holes.(Fig.12)

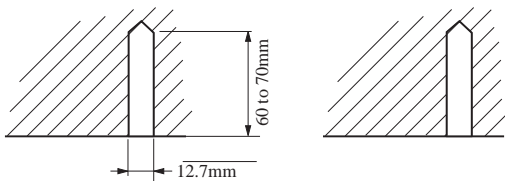

(Fig. 13)

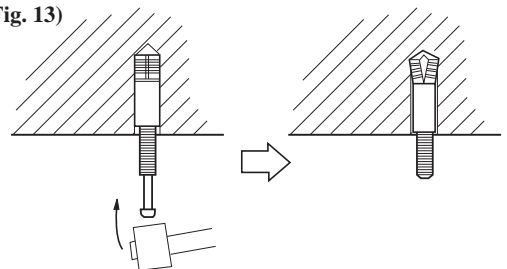

Insert the anchor bolts into the drilled holes, and drive the pins completely into the anchor bolts with a hammer. (Fig. 13)

# Installation of Indoor Unit

## 3. INSTALLING BRACKETS

Install the brackets with nuts, washers and spring washers.(Fig. 14)

(Fig. 14)

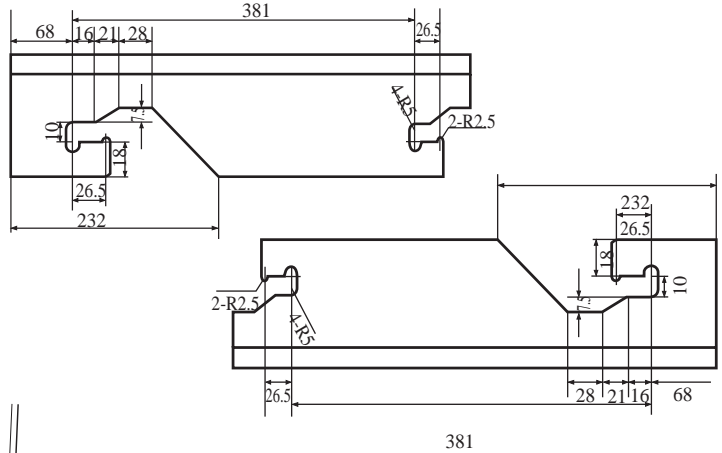
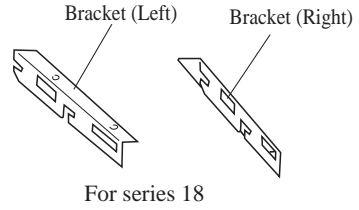
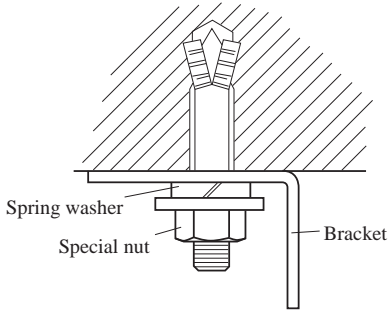

## 4. INSTALLING INDOOR UNIT

Reset the hex bolts as shown in Fig.15.

(Fig. 15)

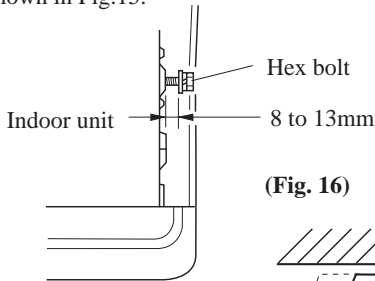

Apply the indoor unit to the brackets.(Fig.16)

(Fig. 16)

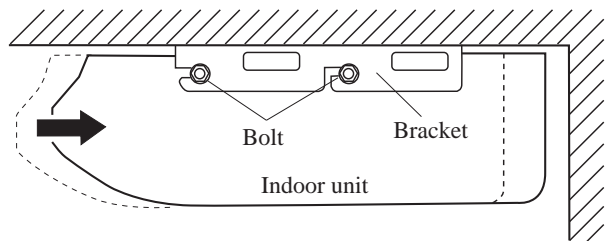

Now, securely tighten the hex bolts in both sides.

## 5. INSTALL THE DRAIN HOSE

Select whether the drain hose will be connected to the left or right side.(Fig.3)

Insert the drain hose into the drain pan, then secure the drain hose with a nylon fastener.(Fig.6)

Wrap the insulation (drain hose)around the drain hose connection.(Fig.7)

Be sure to arrange the drain hose correctly so that it is leveled lower than the drain hose connecting port of the indoor unit.(Fig.8)

# Installation of Indoor Unit

(Fig. 17)

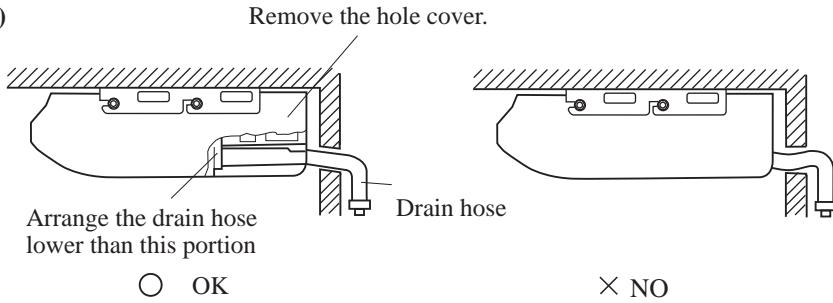

When drain hose is arranged backward. Secure the drain hose with the VT wire. (Fig. 18)

(Fig. 18)

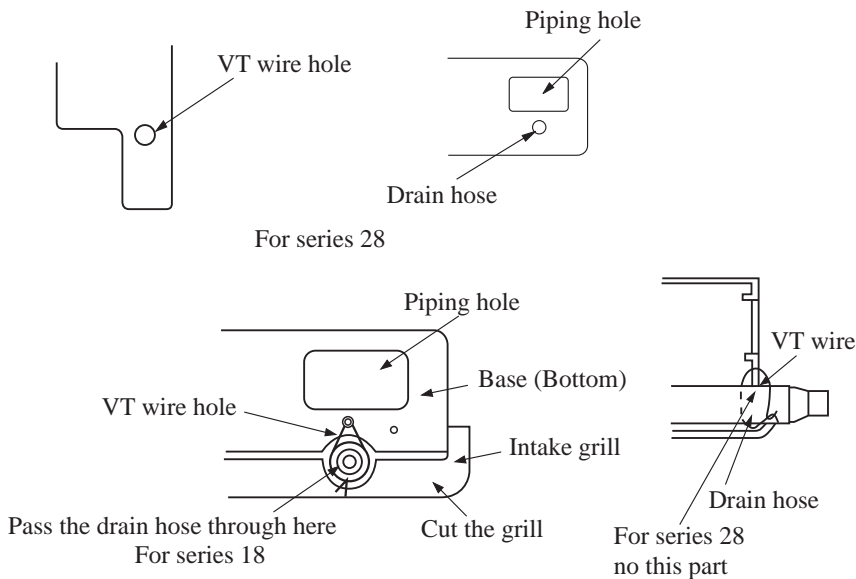

## GAS LEAKAGE INSPECTION

### ⚠ CAUTION

After connecting the piping, check the joints for gas leakage with gas leakage detector.

## HOW TO CONNECT WIRING TO THE TERMINALS

### A. For solid core wiring (or F-cable)(Fig.19A)

- (1) Cut the wire with a wire cutter or wire-cutting pliers, then strip the insulation to about 25mm of the exposed solid wire.
- (2) Using a screwdriver, remove the terminal screw(s) on the terminal board.
- (3) Using pliers, bend the solid wire to form a loop suitable for the terminal screw.
- (4) Shape the loop wire properly, place it on the terminal board and tighten securely with the terminal screw using a screw driver.

# Installation of Indoor Unit

## B. For strand wiring(Fig.19B)

- (1) Cut the wire with a wire cutter or wire-cutting pliers, then strip the insulation to about 10mm of the exposed strand wiring.
- (2) Using a screwdriver, remove the terminal screw(s) on the terminal board.
- (3) Using a round terminal fastener or pliers, securely clamp a round terminal to each stripped wire end.
- (4) Position the round terminal wire, and replace and tighten the terminal screw using a screw driver.

(Fig. 19)

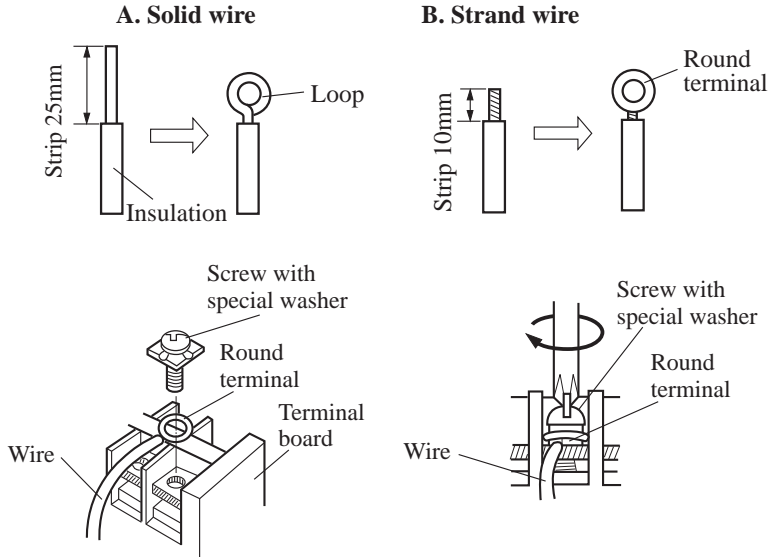

## HOW TO FIXED CONNECTION CORD AND POWER CABLE AT THE CORD CLAMP

After passing the connection cord and power cable through the insulation tube, fasten it with the cord clamp, as shown in Fig.20

(Fig. 20)

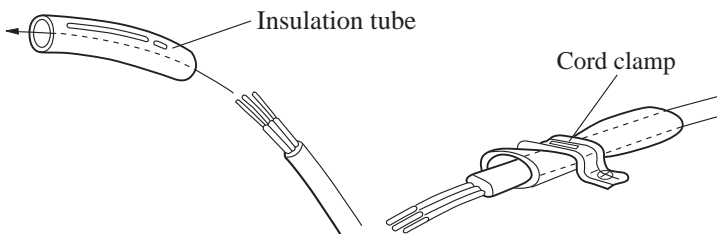

Use VW-1, 0.5 to 1.0 mm thick, PVC tube as the insulation tube.

# ■ Installation of Indoor Unit

## ELECTRICAL WIRING

### ⚠ CAUTION

- (1) Match the terminal block numbers and connection cord colors with those of the outdoor unit.  
Erroneous wiring may cause burning of the electric parts.
- (2) Connect the connection cords firmly to the terminal block. Imperfect installation may cause a fire.
- (3) Always fasten the outside covering of the connection cord with the cord clamp.  
(If the insulator is chafed, electric leakage may occur.)
- (4) Always connect the ground wire.

## 1. INDOOR UNIT SIDE

- (1) Remove the electric component box.

(Fig. 21)

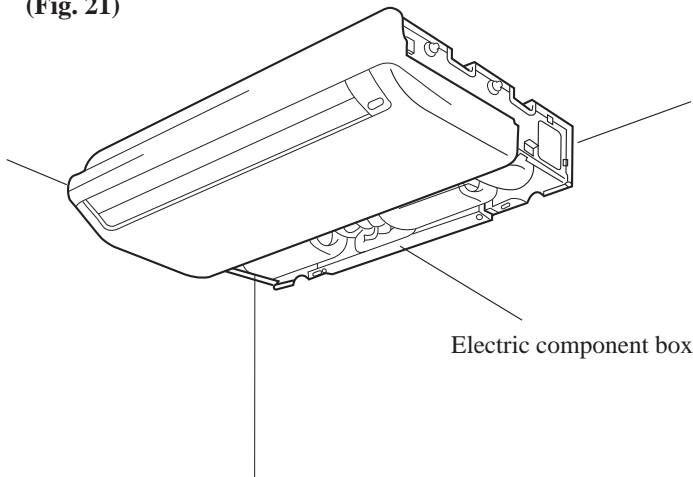

# Installation of Indoor Unit

(Fig. 22)

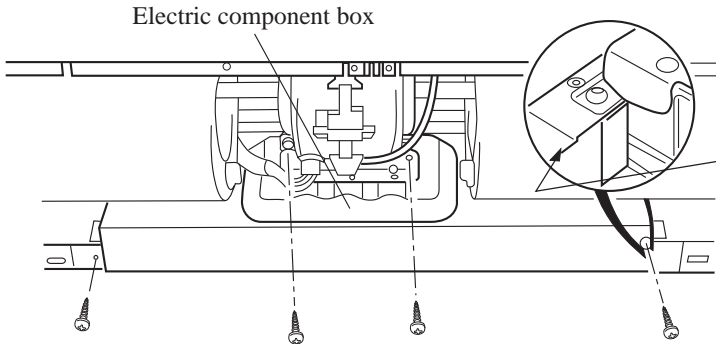

## ⚠ CAUTION

Do not remove the screws. If the screws are removed, the electric component box will fall.

Remove the four tapping screws.

### (2) Pull out the electric component box.

(Fig. 23)

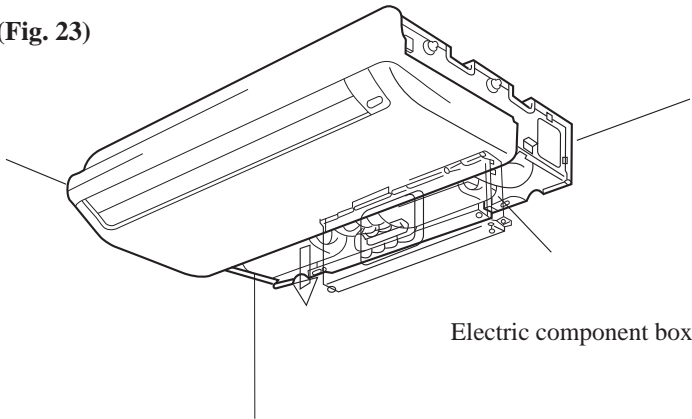

### (3) Remove the electric component box cover.

(Fig. 24)

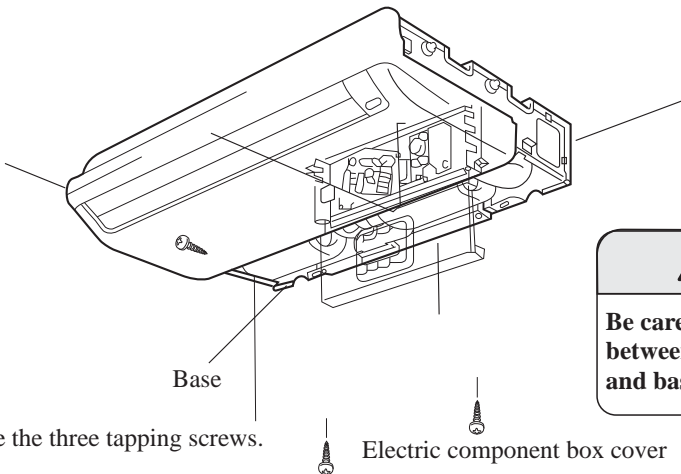

## ⚠ CAUTION

Be careful not to pinch the lead wires between the electric component box and base.

Remove the three tapping screws.

# Installation of Indoor Unit

## (4) Wiring

- (1) Remove the cord clamp.
- (2) Process the end of the connection cords to the dimensions shown in Fig.25.
- (3) Connect the end of the connection cord fully into the terminal block.

(Fig. 25)

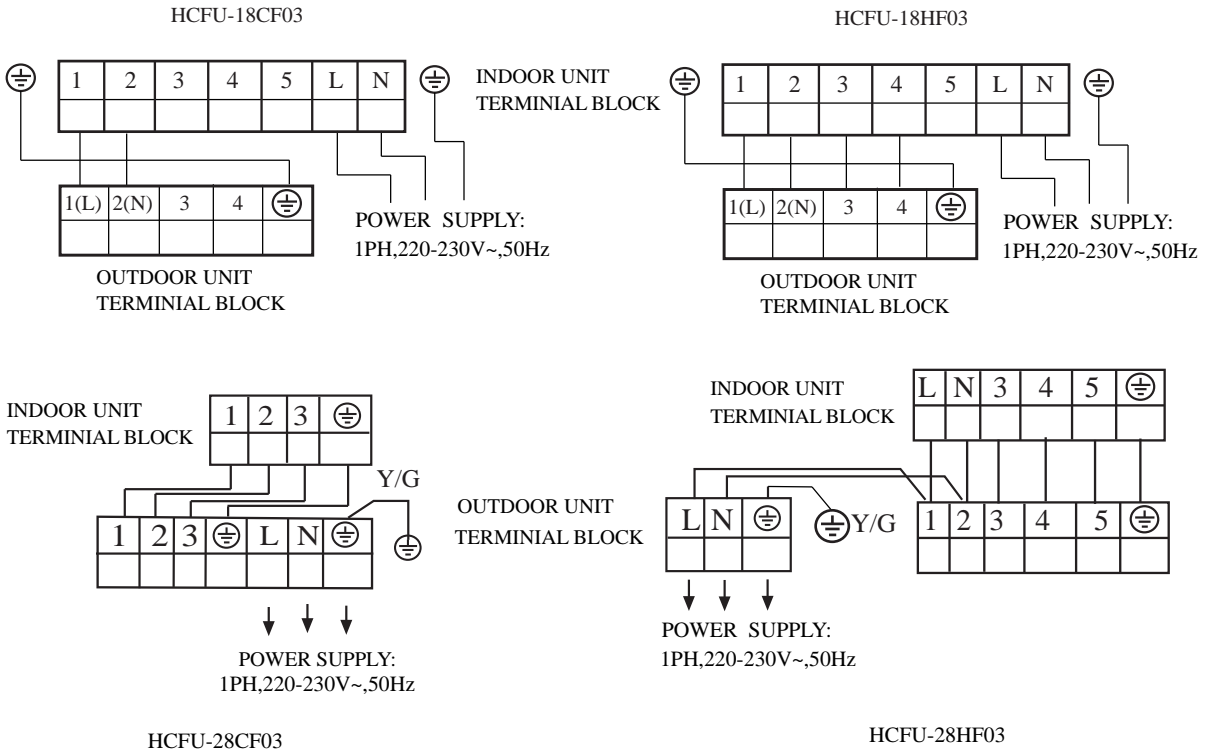

## ELECTRICAL WIRING

### ⚠ WARNING

- (1) Always use a special branch circuit and install a special receptacle to supply power to the room air conditioner.
- (2) Use a circuit breaker and receptacle matched to the capacity of the room air conditioner.
- (3) The circuit breaker is installed in the permanent wiring. Always use a circuit that can trip all the poles of the wiring and has an isolation distance of at least 3mm between the contacts of each pole.
- (4) Perform wiring work in accordance with standards so that the room air conditioner can be operated safely and positively.
- (5) Install a leakage circuit breaker in accordance with the related laws and regulations and electric company standards.

# ■ Installation of Indoor Unit

## ⚠ CAUTION

- (1) The power source capacity must be the sum of the room air conditioner current and the current of other electrical appliances. When the current contracted capacity is insufficient, change the contracted capacity.
- (2) When the voltage is low and the air conditioner is difficult to start, contact the power company the voltage raised.

## TEST RUNNING

### 1. CHECK ITEMS

#### (1) INDOOR UNIT

- (1) Is operation of each button on the remote control unit normal?
- (2) Does each lamp light normally?
- (3) Do not air flow direction louvers operate normally?
- (4) Is the drain normal?

#### (2) OUTDOOR UNIT

- (1) Is there any abnormal noise and vibration during operation?
- (2) Will noise, wind, or drain water from the unit disturb the neighbors?
- (3) Is there any gas leakage?

## CUSTOMER GUIDANCE

Explain the following to the customer in accordance with the operating manual:

- (1) Starting and stopping method, operation switching, temperature adjustment, timer, air flow switching, and other remote control unit operations.
- (2) Air filter removal and cleaning, and how to use air louvers.
- (3) Give the operating and installation manuals to the customer.

## MOUNT THE COVER PLATE AND THE INTAKE GRILL

Note: The following installing procedure only for series 18

### 1. Mount the cover plate. (Right)

- (1) Cut a pipe exit hole in the right plate. This is only when the pipe exits from the right side.  
(This operation is not required when the protrusion is on the top or rear.)

(Fig. 26)

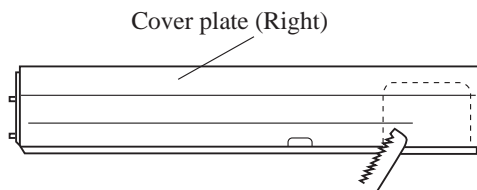



# ■ Installation of Indoor Unit

(2) Join the cover plates (right) and mount with screws.

(Fig. 27)

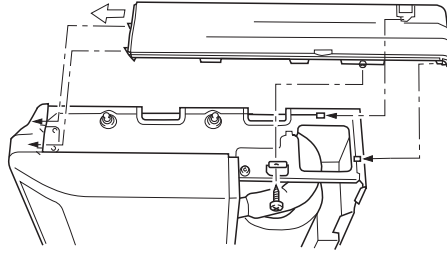

## 2. Mount the cover plate.(Left)

(1) Join the cover plate (left) and mount with screws.

(Fig. 28)

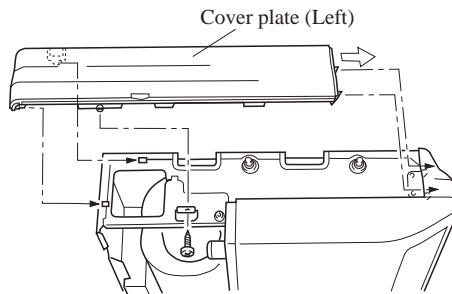

## 3. Mount the intake grill.

(1) Cut the right side of the intake grill. This is only when the pipe exits from the right side

(Fig. 29)

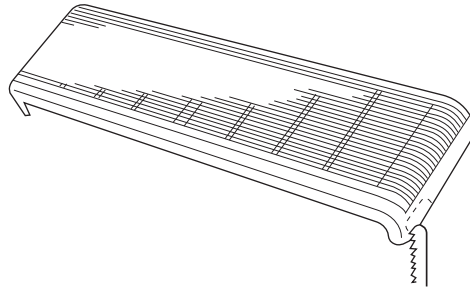

(2) Insert the hinges on the bottom of the intake grill into the holes in the base assembly. Then mount the arms to the three areas on the top of the intake grill.

(Fig.30)

