

## Commercial Air Conditioning

### Duct Type

HDU-24H03/H	(AD242AHAAA+AU242AOAAA)
HDU-28H03/H	(AD282AHAAA+AU282AOAAA)
HDU-42H03/H	(AD142AMBHA+AU142ARBHA)

### Contents

1. Description of Products & Features
2. Specifications
3. Mechanical Data
4. Electrical Data
5. Electrical Control Functions
6. Diagnostic Information
7. Installation Instruction
8. Exploded Views & Part Lists

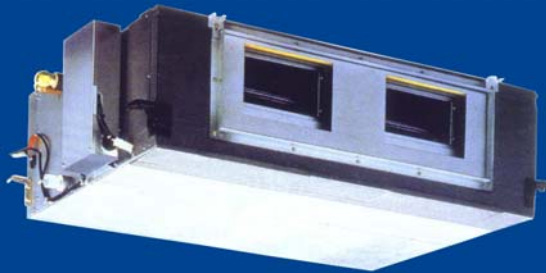

### ● Features

- High static pressure 196Pa
- Flexible setting of the air outlet
- Super-silence design
- Wired Remote Control

# 1. DESCRIPTION OF PRODUCTS & FEATURES

## 1.1 Products coding direction

### Old code

**H DU - 24 H 03/ H**

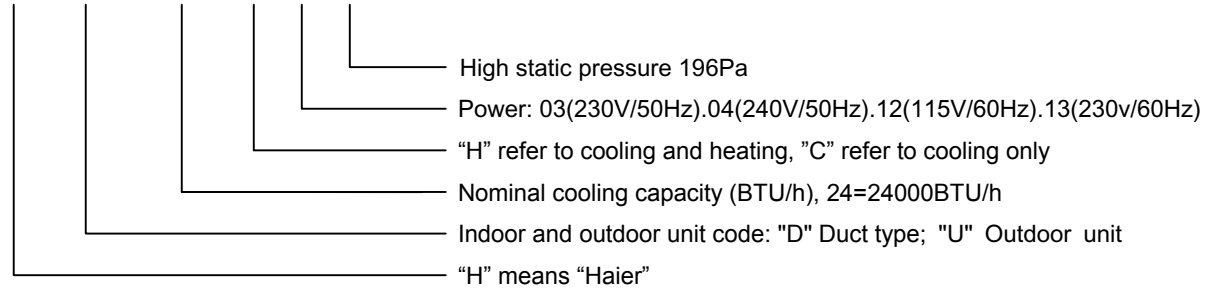

### New code

**A D 24 2 A H A A A**

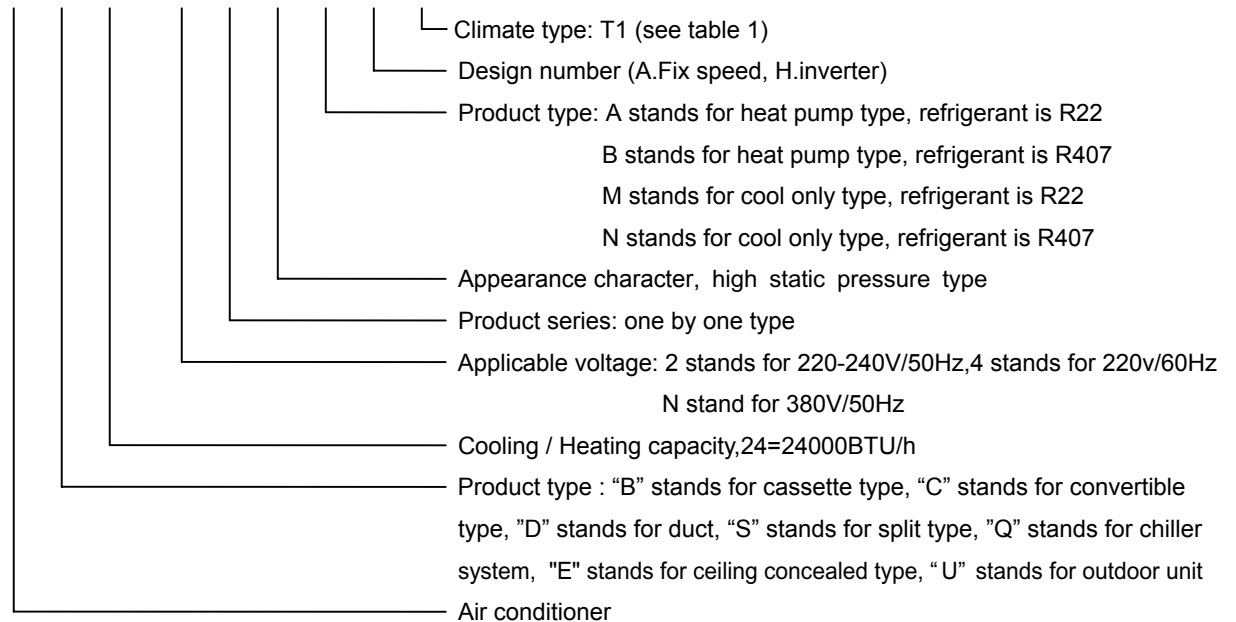

## 1.2 Brief Introduction to T1、T2、T3 working condition

Table 1

Type of Air Conditioner	Climate type		
	T1	T2	T3
Cool only	18°C~43°C	10°C~35°C	21°C~52°C
Heat pump	-7°C~43°C	-7°C~35°C	-7°C~52°C
Electricity heating	~43°C	~35°C	~52°C

## 1.3 Operating Range of air conditioners

### Normal condition

Operation	Operation Range Outside / Inside
Cooling	15 <sup>0</sup> C – 43 <sup>0</sup> C
Drying	15 <sup>0</sup> C – 43 <sup>0</sup> C
Heating	-7 <sup>0</sup> C – 18 <sup>0</sup> C

## 1.4 Brief Introduction to Series of Products

### i) Seriation of products:

The following air duct type air conditioners are now available for export:

HDU-24H03/H HDU-28H03/H HDU-42H03/H

### ii) Features of Products:

#### a. Totally concealed machine body

All the machine body is to be installed inside the ceiling, having no effect on the beauty of the room and without taking any room space.

#### b. Air intake via the rear air intake duct

This new design has changed the former unique pattern of air intake, and a larger distance between air intake and air return cycles as well as better air quality can be achieved.

#### c. Flexible and easier installation

The machine body is to be installed in a totally concealed way, its fan system has a longer distance coverage so as to supply its airflow to several rooms, and the indoor unit may be installed inside the ceiling of a room or corridor. The installation is simple and flexible, and there is no need to have specified personnel for management, thus cutting down the expenses; the machine is lighter and smaller, and convenient for installation, it takes an extremely small building space, thus lower the construction cost; the indoor unit is to be concealed inside the ceiling, and hence the usable space can be saved and the room decoration will not be affected.

## 2. SPECIFICATION

Item		Model	HDU-24H03/H		
Function			Cooling	Heating	
Capacity		BTU/h	24000	26000	
Total power input		W	2800	2700	
EER or COP		BTU/W	8.6	9.6	
Dehumidifying capacity		10 - <sup>3</sup> m <sup>3</sup> /h	3.0		
Power source		PH-V-Hz	1PH,220-230V~,50HZ		
Running current		A	13.0	12.5	
Power cable			/		
Indoor unit	Unit model (color)		AD242AHAAA / WHITE		
	Fan	Type × Number		centrifugal×3	
		Speed	r/min	1230/-/910	
		Air-flow(H-M-L)	m <sup>3</sup> /h	900~1500	
	Heat exchanger	Type / Diameter		TP2M/9.52	
		Flow		6/6	
		Total area	m <sup>2</sup>	0.221	
		Temp. scope	°C	2-7	
		Static pressure	Pa	30	
	Dimension (L×W×H)	External	mm×mm×mm	1410×645×350	
		Package	mm×mm×mm	1557×800×370	
	Drainage pipe (material , I.D./O.D.)			PVC 18/20	
	Control type (wireless/wired)			wired	
	Fresh air hole dimension		mm	/	
	Noise level (H-M-L)		dB(A)	42/36/30	
Weight (net / gross)		kg	48/58		
Outdoor unit	Unit model (color)		AU242AOAAA / WHITE		
	Compressor	Model / Manufacture		ZR34K3-PFJ-522 / COPELAND	
		Type		scroll	
	Fan	Type × Number		Axial ×1	
		Speed	r/min	840/-/640	
		Air-flow(H-M-L)	m <sup>3</sup> /h	3240	
	Heat exchanger	Type / Diameter		TP2M/9.52	
		Flow		10/10	
		Total area	m <sup>2</sup>	0.62	
		Temp. scope	°C	43-60	
	Dimension (L×W×H)	External	mm×mm×mm	948×830×340	
		Package	mm×mm×mm	1050×979×440	
	Drainage pipe (material , I.D./O.D.)			PVC 18/20	
	Refrigerant control method			capillary	
	Defrosting			Auto	
Noise level (H-M-L)		dB(A)	58/-/-		
Four way valve			/		
Weight (net / gross)		kg	74/89		
Piping	Refrigerant	Type	R22		
		Charge	kg	2.4	
	Pipe	Liquid	mm	9.52	
		Gas	mm	15.88	
		Connect method		FLARED	
	Between I.U. & O.U.	Drop	m	MAX :15	
Piping length		m	MAX :30		

Item		Model	HDU-28H03/H	
Function			Cooling	Heating
Capacity		BTU/h	28000	30000
Total power input		W	3450	3200
EER or COP		BTU/W	8.1	9.4
Dehumidifying capacity		10 - <sup>3</sup> m <sup>3</sup> /h	3.0	
Power source		PH-V-Hz	1PH,220-230V~,50HZ	
Running current		A	13.0	12.5
Power cable			/	
Indoor unit	Unit model (color)		AD282AHAAA / WHITE	
	Fan	Type × Number		centrifugal×3
		Speed	r/min	1230/-/910
		Air-flow(H-M-L)	m <sup>3</sup> /h	900~1500
	Heat exchanger	Type / Diameter		TP2M/9.52
		Flow		6/6
		Total area	m <sup>2</sup>	0.24
		Temp. scope	°C	2-7
		Static pressure	Pa	30
	Dimension (L×W×H)	External	mm×mm×mm	1410×645×350
		Package	mm×mm×mm	1557×800×370
	Drainage pipe (material , I.D./O.D.)		PVC 18/20	
	Control type (wireless/wired)		wired	
	Fresh air hole dimension		mm	/
	Noise level (H-M-L)	dB(A)	42/36/30	
Weight (net / gross)	kg	48/58		
Outdoor unit	Unit model (color)		AU282AOAAA / WHITE	
	Compressor	Model / Manufacture		JT95BCBV1L / DAIKIN
		Type	scroll	
	Fan	Type × Number		Axial ×1
		Speed	r/min	840/-/-
		Air-flow(H-M-L)	m <sup>3</sup> /h	3240
	Heat exchanger	Type / Diameter		TP2M/9.52
		Flow		10/10
		Total area	m <sup>2</sup>	0.62
		Temp. scope	°C	43-60
	Dimension (L×W×H)	External	mm×mm×mm	948×830×340
		Package	mm×mm×mm	1050×979×440
	Drainage pipe (material , I.D./O.D.)		PVC 18/20	
	Refrigerant control method		capillary	
	Defrosting		Auto	
Noise level (H-M-L)	dB(A)	58/-/-		
Four way valve		/		
Weight (net / gross)	kg	74/89		
Piping	Refrigerant	Type	R22	
		Charge	kg	2.8
	Pipe	Liquid	mm	9.52
		Gas	mm	15.88
		Connect method	FLARED	
	Between I.U. & O.U.	Drop	m	MAX :15
Piping length		m	MAX :30	

Item		Model	HDU-42H03/H	
Function			Cooling	Heating
Capacity		BTU/h	42000	44000
Total power input		W	4800	4700
EER or COP		BTU/W	8.75	9.46
Dehumidifying capacity		10 - <sup>3</sup> m <sup>3</sup> /h	5.0	
Power source		PH-V-Hz	3N,380-400V~,50HZ	
Running current		A	9.2	9.0
Power cable			/	
Indoor unit	Unit model (color)		AD42NAHAAA / WHITE	
	Fan	Type × Number		centrifugal×3
		Speed	r/min	1090/-/930
		Air-flow(H-M-L)	m <sup>3</sup> /h	1560~2580
	Heat exchanger	Type / Diameter		TP2M/9.52
		Flow		3/3
		Total area	m <sup>2</sup>	0.338
		Temp. scope	°C	2-7
		Static pressure	Pa	30
	Dimension (L×W×H)	External	mm×mm×mm	1410×645×350
		Package	mm×mm×mm	1557×800×370
	Drainage pipe (material , I.D./O.D.)		PVC 18/20	
	Control type (wireless/wired)		wired	
	Fresh air hole dimension		mm	/
	Noise level (H-M-L)	dB(A)	42/36/30	
Weight (net / gross)	kg	62/77		
Outdoor unit	Unit model (color)		AU42NAQAAA / WHITE	
	Compressor	Model / Manufacture		H23A62QDBE / Bristol
		Type	scroll	
	Fan	Type × Number		Axial ×2
		Speed	r/min	840/-/-
		Air-flow(H-M-L)	m <sup>3</sup> /h	6000
	Heat exchanger	Type / Diameter		TP2M/9.52
		Flow		5/5
		Total area	m <sup>2</sup>	0.92
		Temp. scope	°C	43-60
	Dimension (L×W×H)	External	mm×mm×mm	948×1225×340
		Package	mm×mm×mm	1050×1375×440
	Drainage pipe (material , I.D./O.D.)		PVC 18/20	
	Refrigerant control method		capillary	
	Defrosting		Auto	
Noise level (H-M-L)	dB(A)	64/-/-		
Four way valve		/		
Weight (net / gross)	kg	91/111		
Piping	Refrigerant	Type	R22	
		Charge	kg	4.0
	Pipe	Liquid	mm	9.52
		Gas	mm	19.05
		Connect method	FLARED	
	Between I.U. & O.U.	Drop	m	MAX :30
Piping length		m	MAX :50	

3. Mechanical data

Indoor Unit

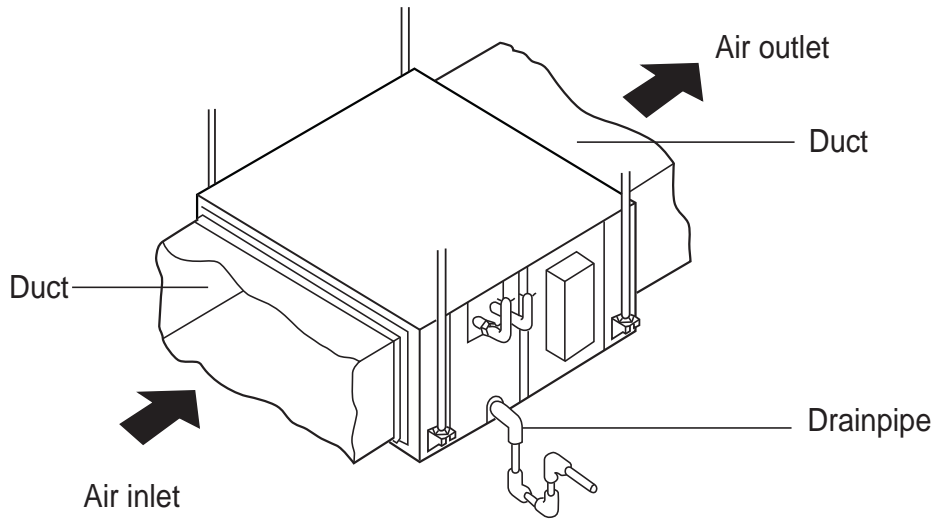

Outdoor Unit

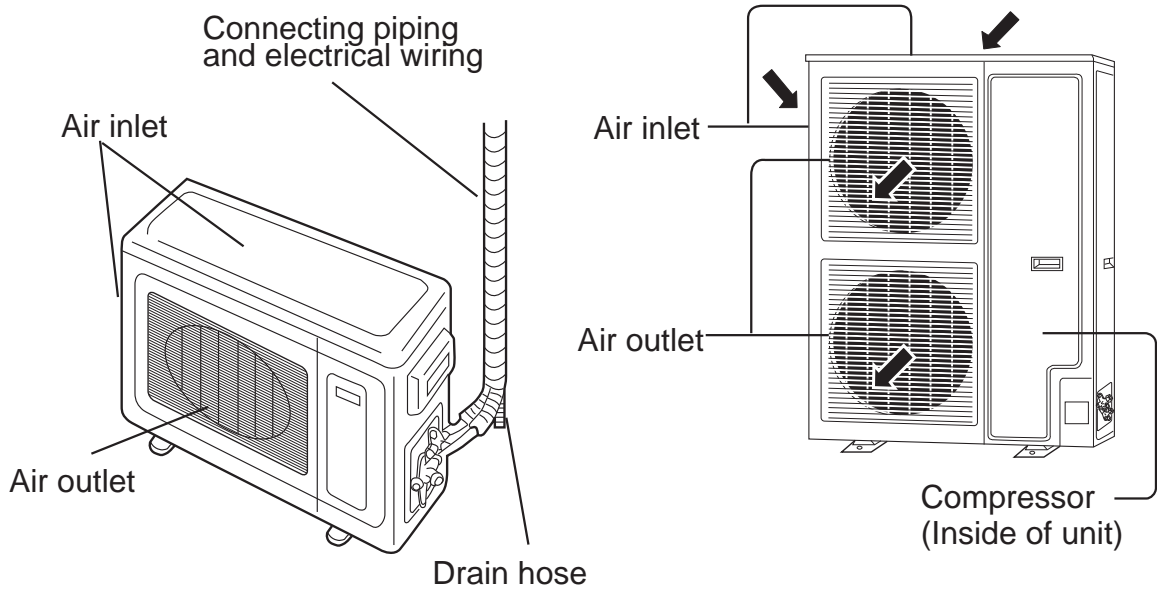

HDU-24H03/H  
HDU-28H03/H

HDU-42H03/H

indoor unit dimensions

HDU-24H03/H HDU-28H03/H

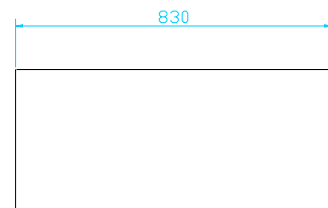
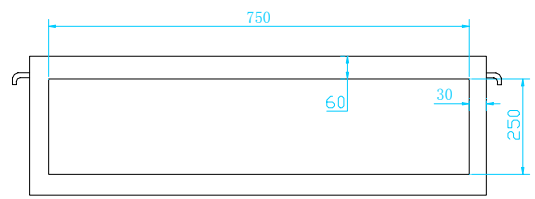
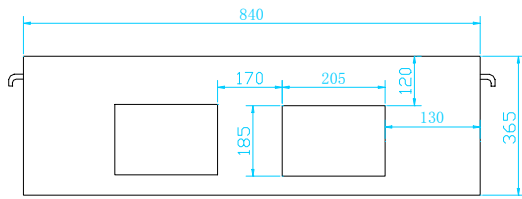

HDU-42H03/H

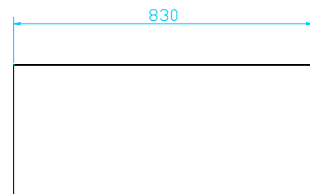
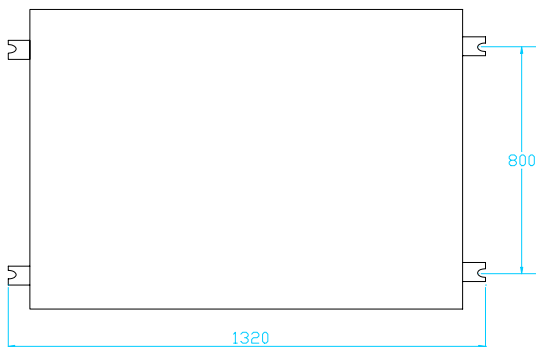
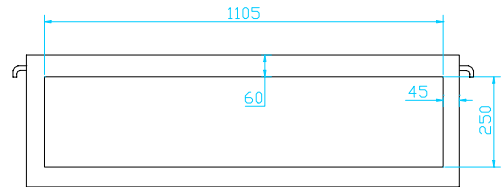
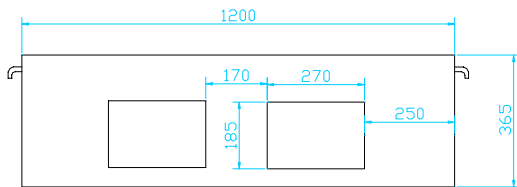



# Operation

Buttons and display of the wire controller.

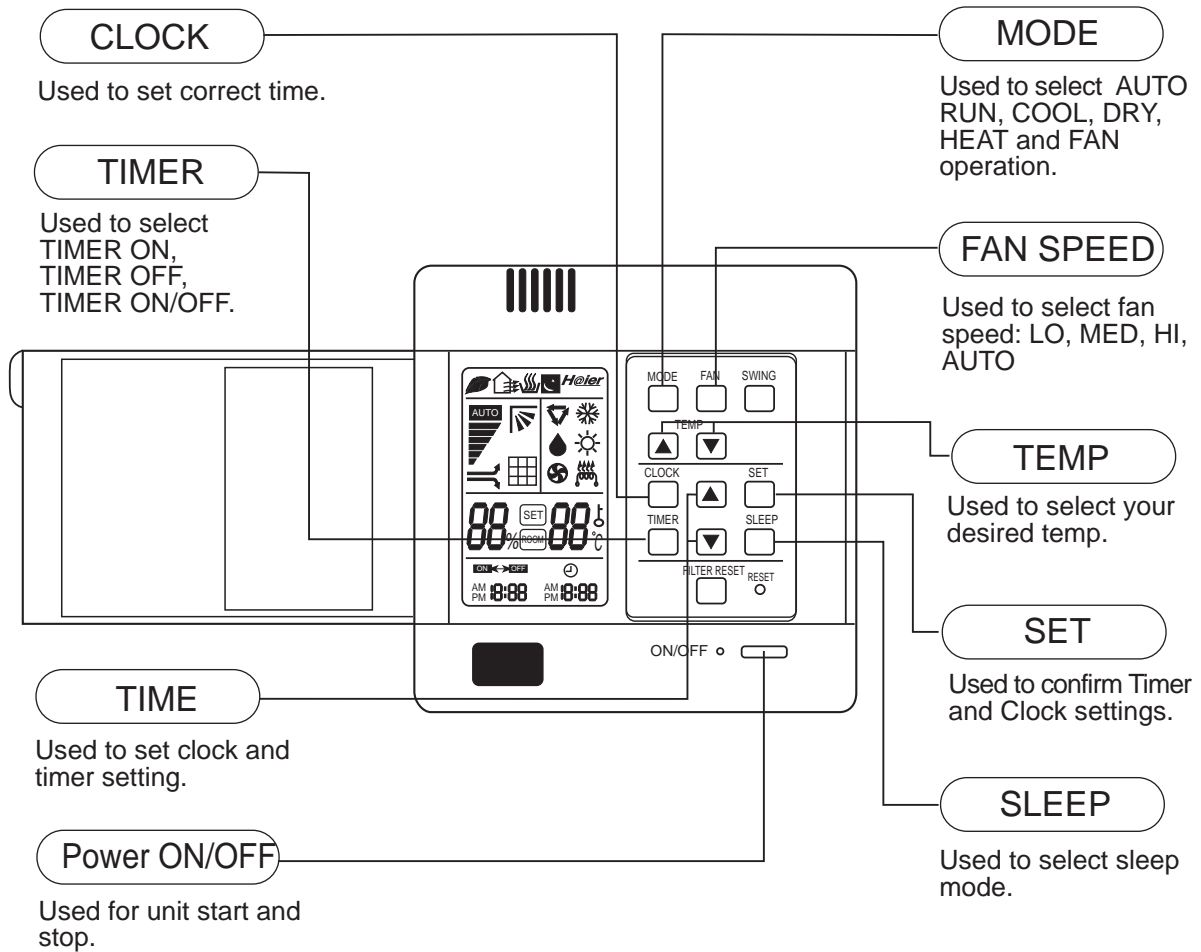

**Cautions:**  
On cooling only unit, heating mode is not available.

**Note:**  
The above information is the explanation of the displayed information therefore varies with those displayed in actual operation.

# Operation

Buttons and display of the wire controller.

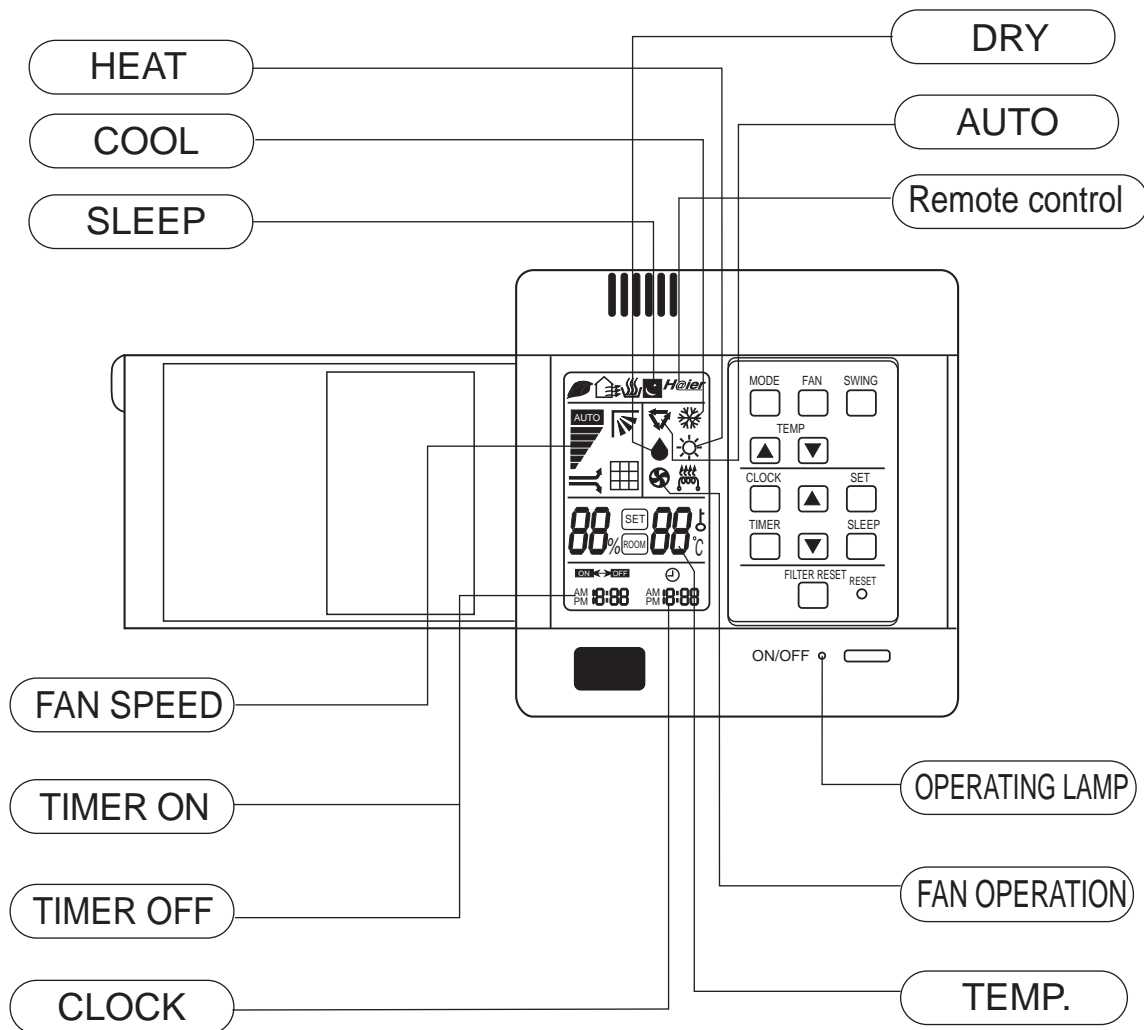

## Clock

When unit is started for the first time, clock should be adjusted as follows:

- Press CLOCK button, "AM" or "PM" flashes.
- Press ▲ or ▼ to set correct time. Each press will increase or decrease 1min. If the button is kept depressed, time will change quickly.
- After time setting is confirmed, press SET, "AM" and "PM" stop flashing, while clock starts working.

# ■ OPERATION

The air conditioner has the function of **POWER FAILURE RESUME**.

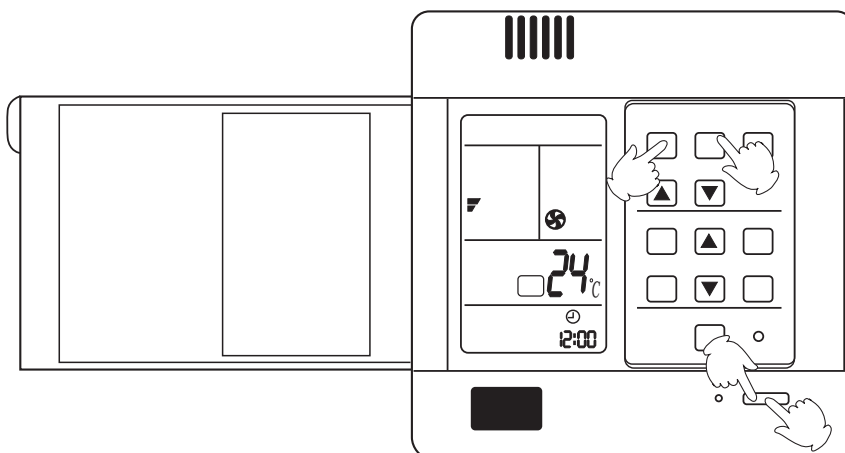

## Fan operation

Enjoy yourself by just a gentle press.

### (1) Unit start

Press ON/OFF button, unit starts.  
Previous operation status appears on display.  
(Not Timer setting)  
Power indicator lights up.

### (2) Select operation mode

Press MODE button. For each press, operation mode changes as follows:



Unit will run in selected mode.  
stop display at " FAN.

For cooling only type no " HEAT " function.

### (3) Fan

Press FAN button. For each press, fan speed changes as follows:



Unit will run at selected fan speed.

### (4) Unit stop

Press ON/OFF button.  
Only time and room temp remains on LCD.  
All indicators go out.  
Vertical flap closed automatically.

## Hints

Wire controller can memorize settings in each operation mode. To run it next time just select the operation mode and it will start with the previous setting.

No reselecting is needed.(TIMER ON/OFF needs reselecting)

In FAN mode, temp. can't be set.

# ■ OPERATION

## AUTO RUN, COOL, HEAT and DRY operation

### Recommendations

- Use COOL in summer.
- Use HEAT in winter.
- Use DRY in spring, autumn and in damp climate.

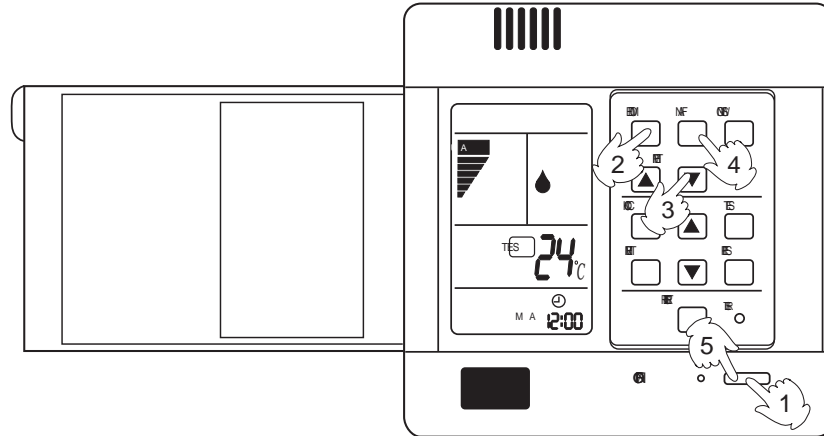

### (1) Unit start

Press ON/OFF button, unit starts.  
Previous operation status appears on display  
(Not Timer setting). Power indicator lights up.

### (2) Select operation mode

Press MODE button. For each press, operation mode changes as follows:



Unit will run in operation mode displayed on LCD.  
Stop display at your desired mode.

### (3) Select temp. setting

Press TEMP button

- ▲ Every time the button is pressed, temp. setting increases 1°C.  
If button is kept depressed, temp. setting will increase quickly.
- ▼ Every time the button is pressed, temp. setting decreases 1°C.  
If button is kept depressed, temp. setting will decrease quickly.

Unit will start running to reach the temp. setting on LCD.

### (4) Fan speed selection

Press FAN button. For each press, fan speed changes as follows:

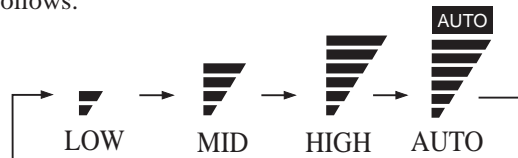

Unit runs at the speed displayed on LCD.

In HEAT mode, warm air will blow out after a short period of time due to cold-draft prevention function.  
In DRY mode, when room temp. becomes 2°C higher than temp. setting, unit will run intermittently at LOW speed regardless of FAN setting.

### (5) Unit stop

Press ON/OFF button.  
Only time and room temp remains on LCD.  
All indicators go out.  
Vertical flap closes automatically.

### Hints

Wire controller can memorize each operation status. When starting it next time, just press ON/OFF button and unit will run in previous status.

# ■ OPERATION

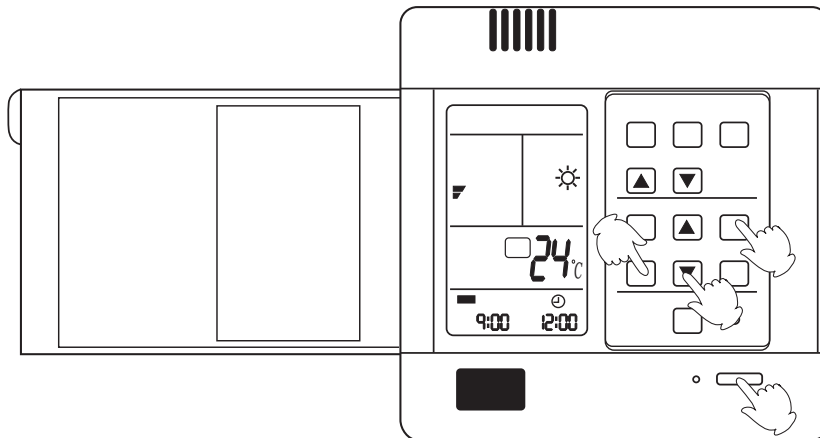

## TIMER operation

Set Clock correctly before starting Timer operation.

You can let unit start or stop automatically at following time: Before you wake up in the morning, or get back from outside or after you fall asleep at night.

### TIMER ON/OFF

(1)After unit start, select your desired operation mode.

Operation mode will be displayed on LCD.  
Power indicator lights up.

(2)TIMER mode selection

Press TIMER button to change TIMER mode.  
Every time the button is pressed, display changes as follows:



Select your desired TIMER mode (ON or OFF)

(3)Timer setting

Press TIME ▲ / ▼ button.

▲ Every time the button is pressed, time increases 10min.  
If button is kept depressed, time will change quickly.

▼ Every time the button is pressed, time decreases 10min.  
If button is kept depressed, time will change quickly.

Time will be shown on LCD. It can be adjusted within 24hours.

(4)Confirming your setting

After setting correct time, press SET button to confirm  
"ON" or "OFF" stops flashing.

Time displayed: Unit starts or stops at x hour x min (ON or OFF).

Timer mode indicator lights up.

## To cancel TIMER mode

Just press TIMER button several times until TIMER mode disappears.

### Hints

Wire controller possesses memory function, when use TIMER mode next time, just press SET button after mode selecting if timer setting is the same as previous one.

# ■ OPERATION

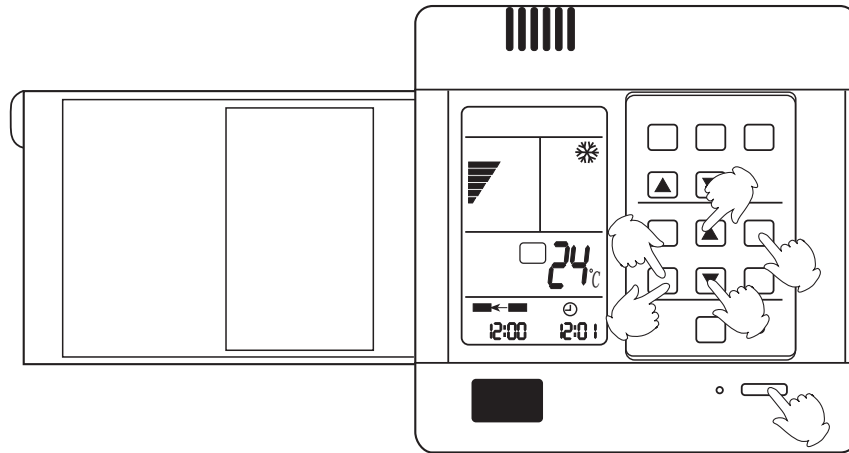

## TIMER ON-OFF

(1) After unit start, select your desired operation mode

Operation mode will be displayed on LCD.  
Power indicator lights up.

(2) Press TIMER button to change TIMER mode

Every time the button is pressed, display changes as follows:



Select  $\begin{matrix} \text{ON} \\ \text{OFF} \end{matrix}$ .

(3) Time setting for TIMER ON

Press TIME button.

- ▲ Every time the button is pressed, time increases 10min.  
If button is kept depressed, time will change quickly.
- ▼ Every time the button is pressed, time decreases 10min.  
If button is kept depressed, time will change quickly.  
Time will be shown on LCD.  
It can be adjusted within 24hours.

AM refers to morning and PM to afternoon.

(4) Time confirming for TIMER ON

After time setting, press TIMER button to confirm.  
"ON" stops blinking, While "OFF" starts blinking.  
Time displayed: Unit starts at Xhour X min.

(5) Time setting for TIMER OFF

Follow the same procedures in "Time setting for TIMER ON".

(6) Time confirming for TIMER OFF

After time setting, press SET button to confirm  
"OFF" stops flashing.  
Time displayed: Unit stops at X hour X min.

## To cancel TIMER mode

- Just press TIMER button several times until TIMER mode disappears.
- According to the Time setting sequence of TIMER ON or TIMER OFF, either Start-Stop or Stop-Start can be achieved.

# ■ OPERATION

## Comfortable Sleep

At night, before going to bed you can press down the SLEEP button on the controller and the air-conditioner will run by the comfortable sleeping mode to make you sleep more comfortable.

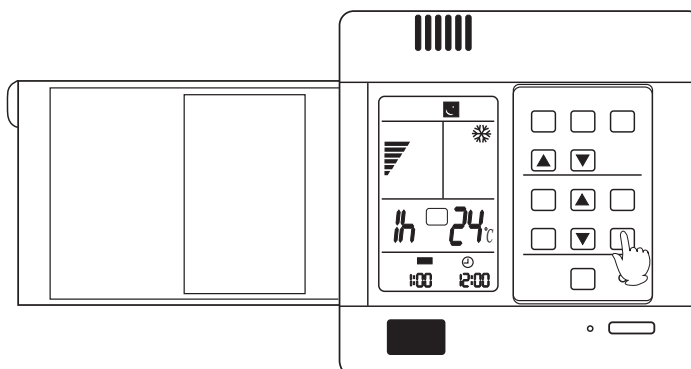

Press SLEEP button once to make the air conditioner have the previous-set sleep time (first power-on is "1h"), the sleep symbol will appear. Press time button ▲/▼, you can choose the time in 1~8 hours. Each press of ▲/▼, the time increases/reduces 1 hour and "xh" appears in the humidity setting part, "OFF" appears in "TIMER OFF" display part and timer-off time; press SLEEP button again to cancel sleep function, the sleep symbol disappears.

## In cooling, dehumidifying mode

One hour after sleeping operation start, the temp. is 1°C higher than the setting one. After another hour the temp. rises 1°C and then run continuously for another 6 hrs' and then close. The actual temp. is higher than the setting one which is to prevent from being too cool to your sleep.

## In heating mode

One hour after start up, the temp. decrease 2°C lower than the setting one. After another hour decrease by more 2°C.

The temperature will automatically rise by 1°C after another 3 hrs' operation, and then automatically close after 3 hrs' continuous operation. The actual temperature is lower than the setting one which is to prevent from being too hot to your sleep.

Note:

- In AUTO mode, unit will run in SLEEP function according to the operation mode.
- After setting SLEEP function, it is forbidden to calibrate clock.
- If the set sleep-time does not reach 8 hours, the unit will stop operation automatically after set time is complete.
- Set "TIMER-OFF" function first, then set SLEEP, and the sleep-set is performance; set TIMER-ON function first, the sleep function can only be set before TIMER-ON; if set the SLEEP function first, the TIMER function can not be set.

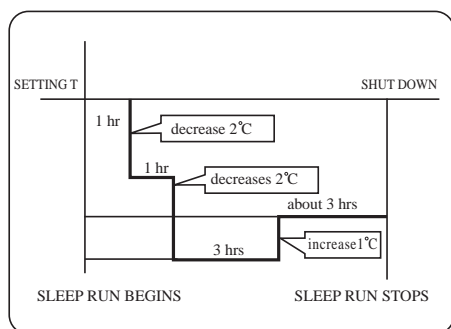

Heat mode

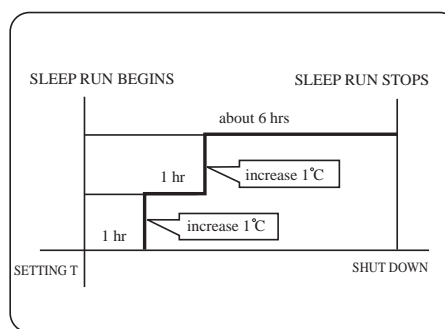

Cooling mode

# ■ INSTALLATION MANUAL FOR WIRE CONTROLLER

## 1. Remove upper part of wire controller

Remove upper part of wire controller by press.

PCB is mounted on lower part of wire controller, be careful not to damage it.

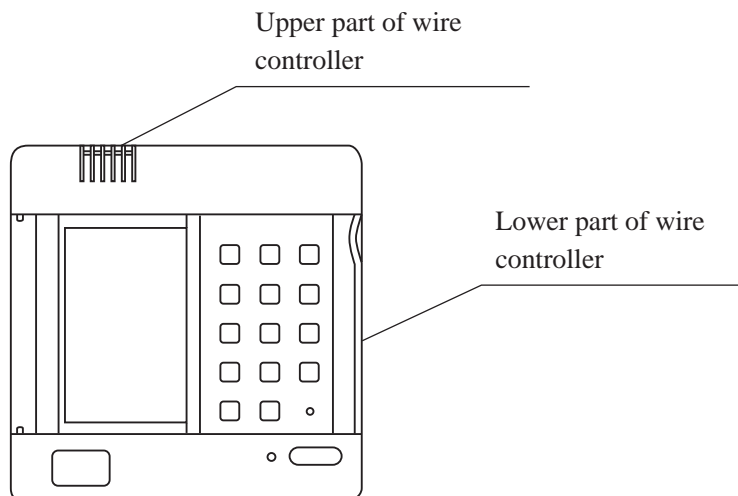

## 2. Install wire controller

- (1) For exposed installation,  
use 2 wood screws (accessory).
- (2) For recessed installation,  
use 2 wood screws (accessory).

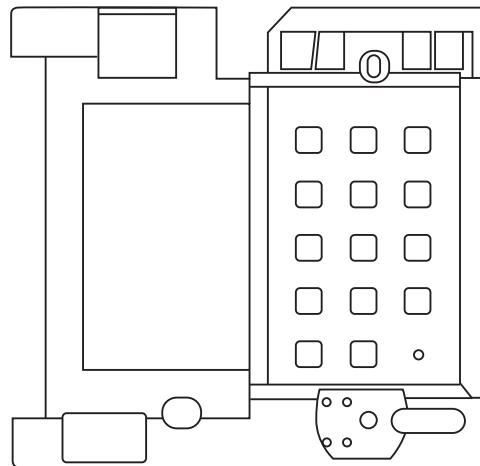

## Note

Try as far as possible a flat surface for installation. Don't use excessive force when tightening screws, or lower part might get deformed.



# ■ INSTALLATION MANUAL FOR WIRE CONTROLLER

## 3. Indoor unit wiring

Connect terminals (A,B,C,D) on lower part of wire controller to terminals (A,B,C,D) on PCB of indoor unit.

### Hint

When make wiring, please keep a distance between wires and power supply cord.

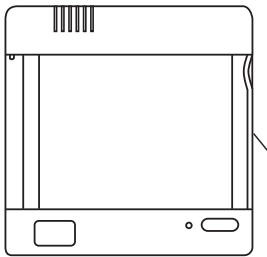
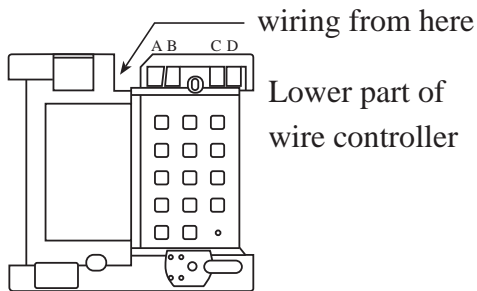

### Wire size

Cord kind	Shield wire (4 core) (refer to Hint 3,4)
Size	0.33mm <sup>2</sup>

- Use shielded wires for telecommunication between wire controller and indoor unit; indoor unit and outdoor unit. Ground the shield on one side. Otherwise misoperation because of noise may occur.
- Signal wire is self-provided.

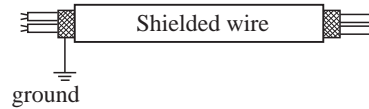

### Hint

Tread surface of the terminal well so that shielding may not contact other part.

## 4. Replace the upper part of wire controller

Be careful not to press the wiring.

### Hint

1. Switch box and cord for wiring are not supplied.
2. Don't touch PCB with hand.



model: HDU-24H03/H HDU-28H03/H

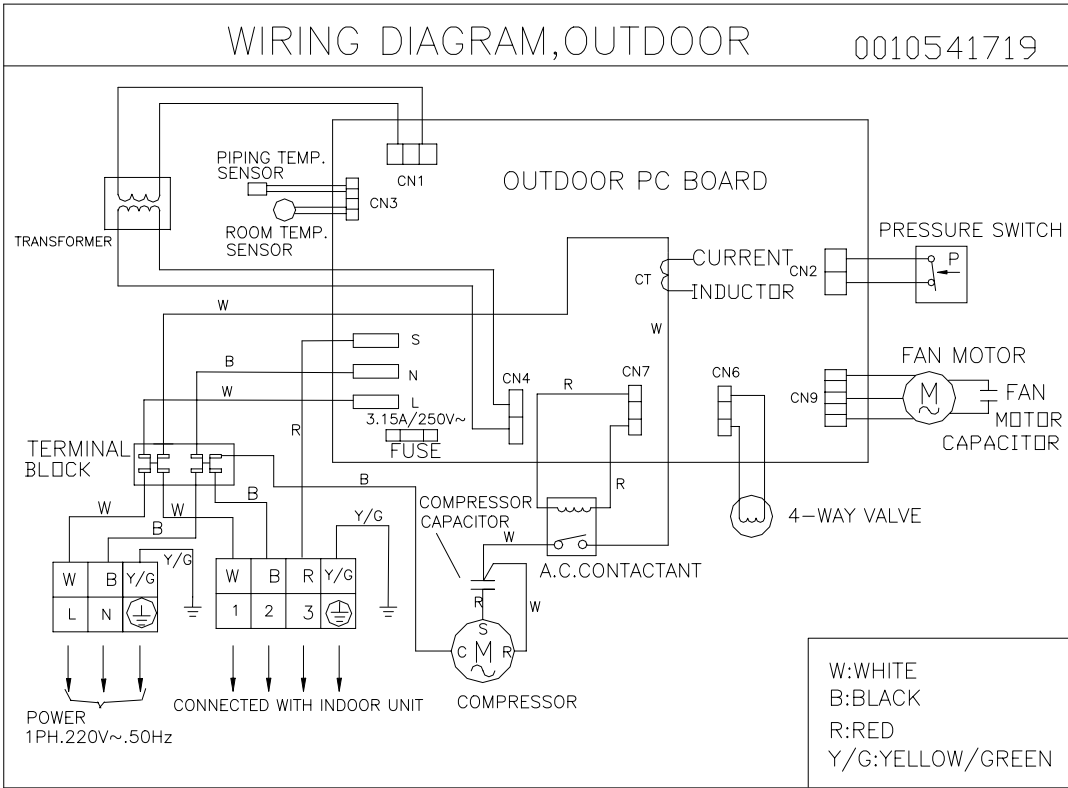

model: HDU-42H03/H

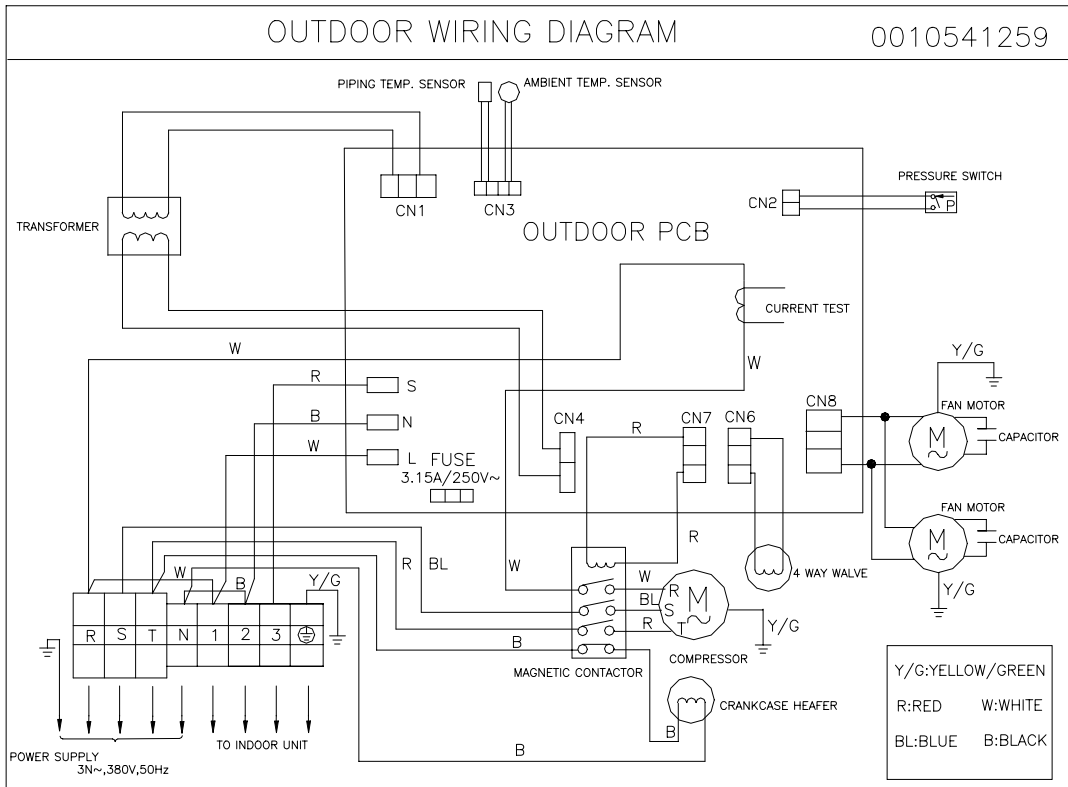

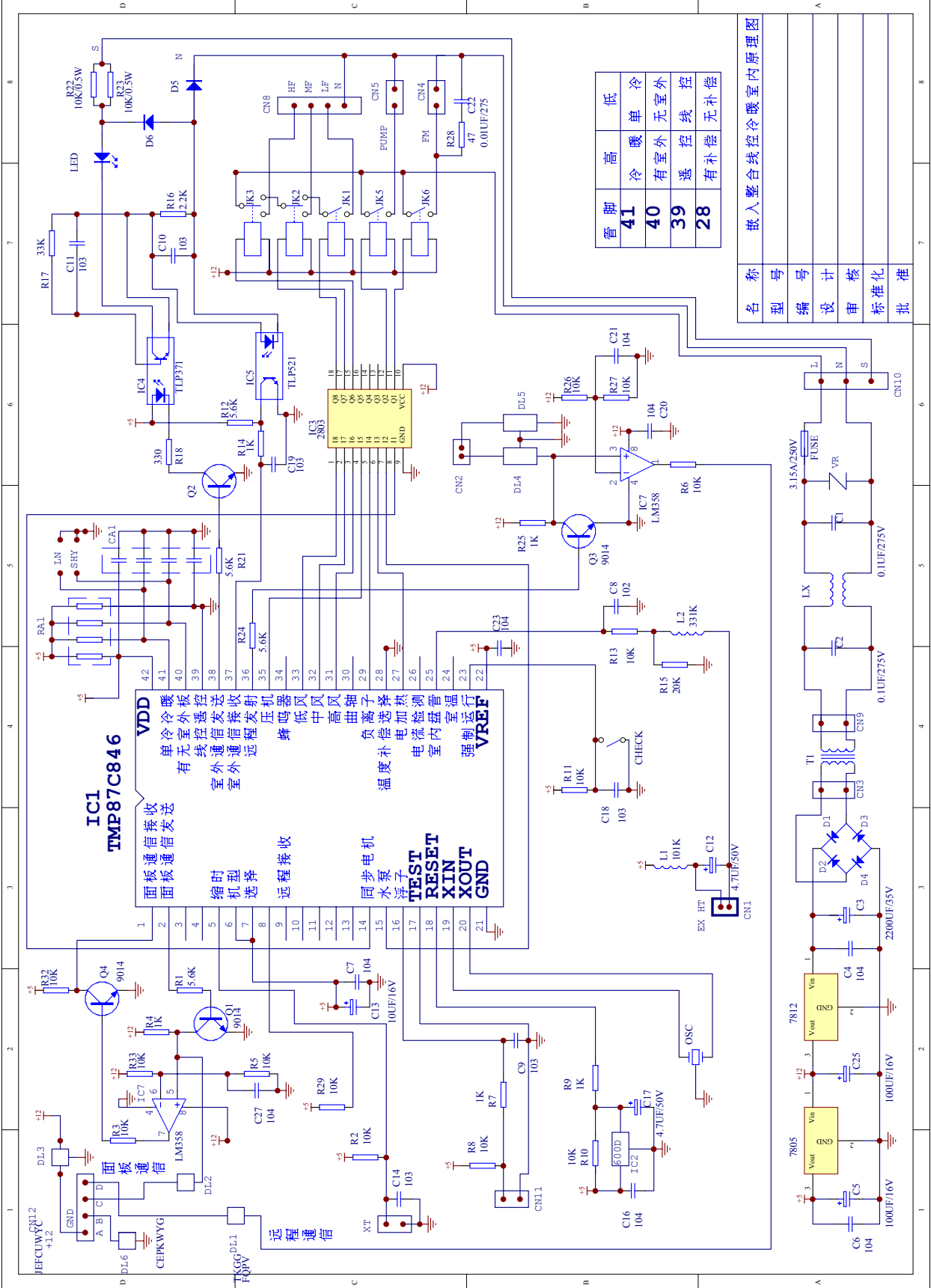

管脚	高	低
41	冷	暖
40	有室外	无室外
39	遥控	线控
28	有补偿	无补偿

名称	嵌入整合线控冷暖室内原理图
型号	
编号	
设计	
审核	
标准化	
批准	

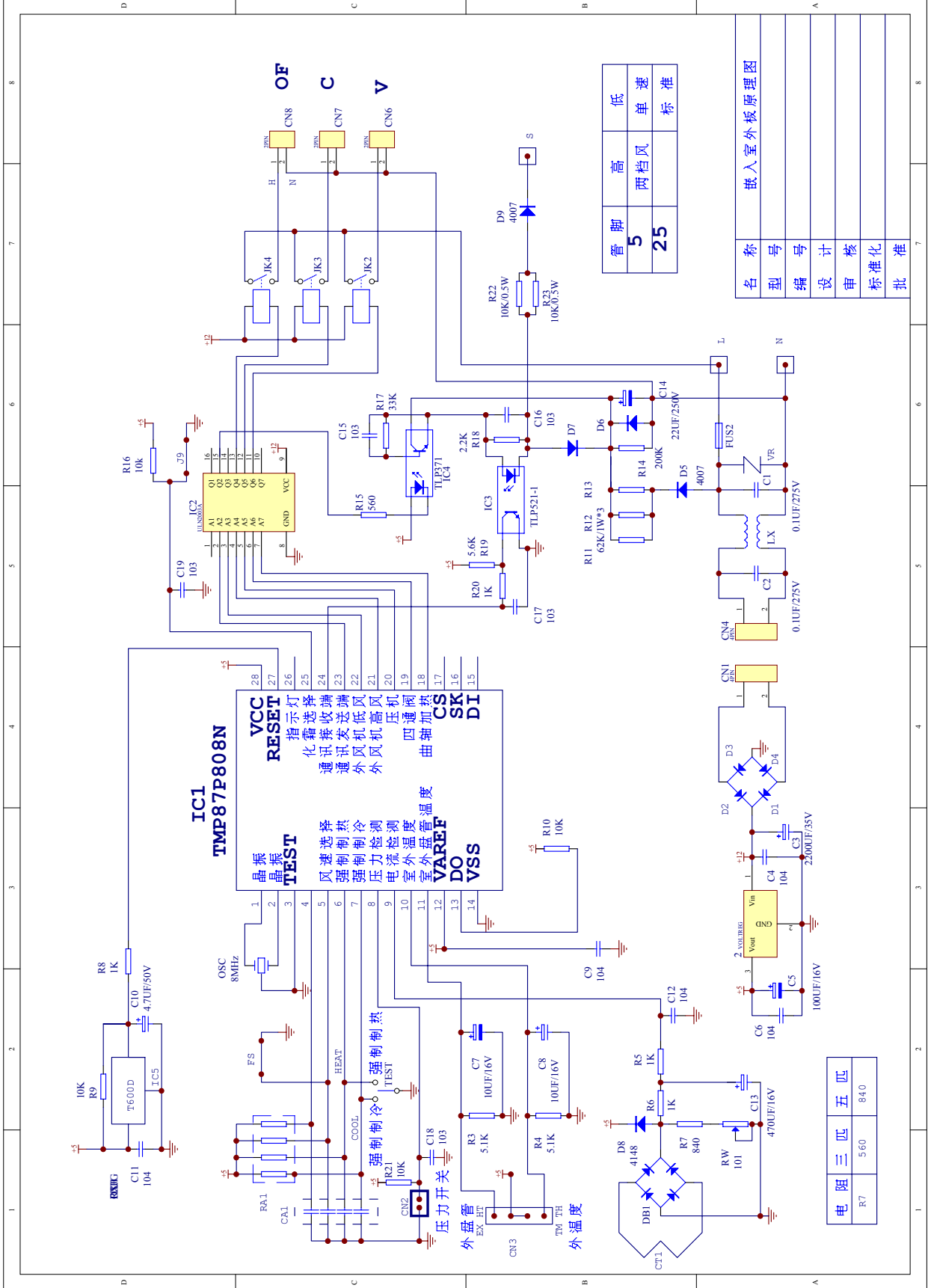

管脚	高	两档风	低
5			
25			
	单速		
	标准		

名称	嵌入室外板原理图			
型号				
编号				
设计				
审核				
标准化				
批准				

电阻	三匹	五匹
R7	560	840



## 5 ELECTRICAL CONTROL FUNCTIONS

This section includes introduction of items and electrical functions of serial machines

### 5.1 Introduction of electrical control functions

#### 5.1.1 Auto-running

After system is on and turned to auto-running mode, the system shall first choose a suitable operation mode according to present indoor temperature. Then it shall operate under the chosen mode.  $T_r$  represents indoor temperature and  $T_s$  represents set temperature in the following choices.

#### a. To both cold and heat producing machine

For the first time when the machine enters auto-running mode, it shall choose operation mode according to the following listed:

$T_r \geq T_s - 3^\circ\text{C}$  choose cold producing mode ( set temperature is  $T_s + 3$  )

$T_r \leq T_s - 3^\circ\text{C}$  choose heat producing mode ( set temperature is  $T_s - 3$  )

After it enters into auto-running, operating mode shall switch between cold producing and heat producing according to changes of indoor and outdoor temperature. The switching mode is as the following chart showing:

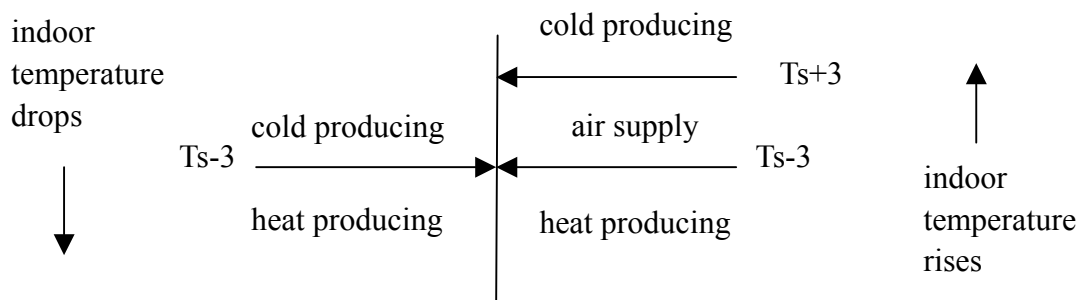

#### b. For only cold-producing machine

For the first time it enters auto-running mode, the system shall choose running mode according to the following listed:

$T_r \geq T_s - 3^\circ\text{C}$  choose cold producing mode ( set temperature is  $T_s + 3^\circ\text{C}$  )

$T_r \leq T_s - 3^\circ\text{C}$  choose ventilation mode

After it enters into auto-running, operation mode shall switch between cold producing and ventilation according to changes of indoor and outdoor temperature. The switching mode is as the following chart shows:

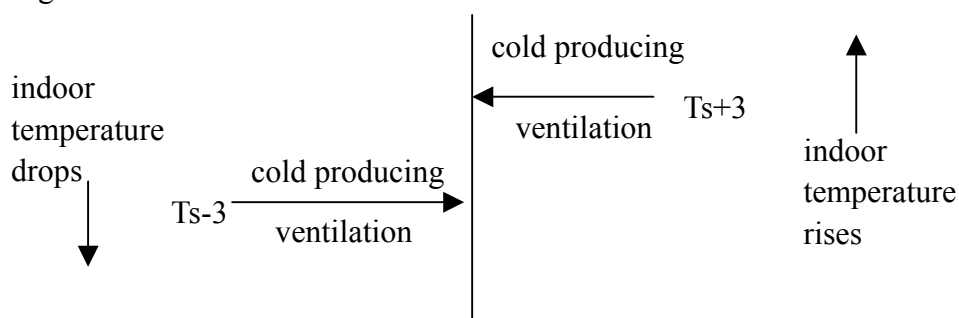

### 5.1.2 Auto wind speed choice

Tr herein after refers to indoor temperature and Ts refers to set temperature.

a. When machine is for cold producing and wind speed is switched from low speed to high speed, switching shall not be enabled until operation under present wind speed exceeds 3 minutes. There is no time lag when switching from high wind speed to low wind speed. Switching shall be as the following chart shows:

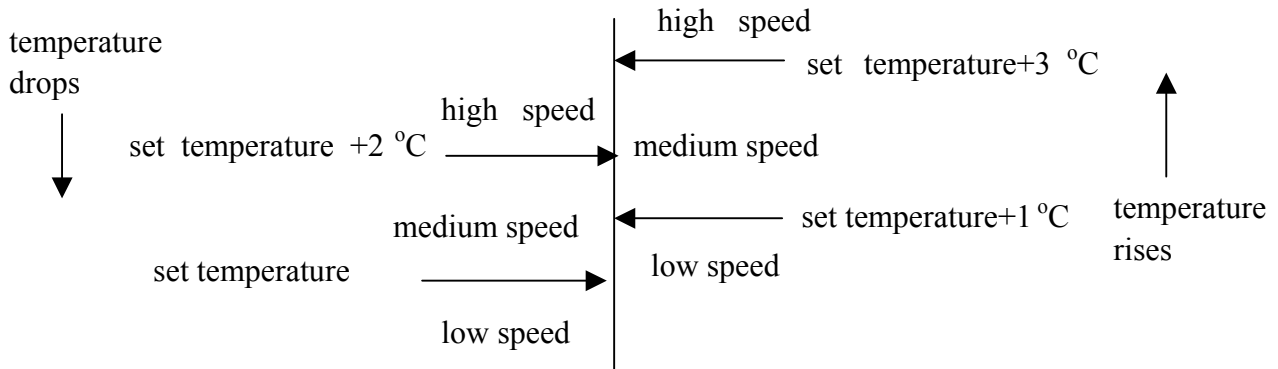

b. During heat producing (suitable for both heat and cold producing machine), when wind speed is switched from low to high, switching shall not be enabled until operation under present wind speed exceeds 3 minutes. There is no time lag when switching from high wind speed to low wind speed.

Switching shall be as the following chart shows:

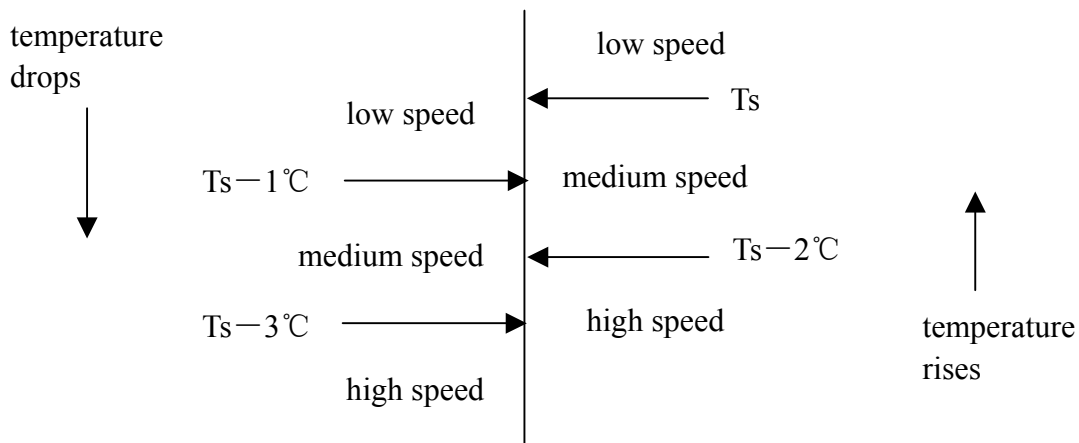

### 5.1.3 Dehumidifying running

When system enters dehumidifying running, air-compressor, outdoor unit and indoor fan shall operate as the following stipulations: (Tr herein after refers to indoor temperature and Ts refers to set temperature)

7.1.3.1  $Tr > Ts + 2\text{ °C}$ , and when air compressor and outdoor fan are continuously running, indoor fan runs in set wind speed. Working section under such status is section A.



5.1.3.2  $T_s \leq T_t \leq T_s + 2 \text{ } ^\circ\text{C}$ , air compressor and outdoor fan runs for 10 minutes with a 6 minutes' break, and indoor fan runs in low speed. Working section under such status is section B.

5.1.3.3  $T_r < T_s$ , air compressor and outdoor fan stops running, indoor air fan runs in low speed. Working section under such status is section C.

After system enters dehumidifying operation mode, it shall switch among section A, B, and C with changes of indoor temperature. Switching of operation mode is as the following chart shows:

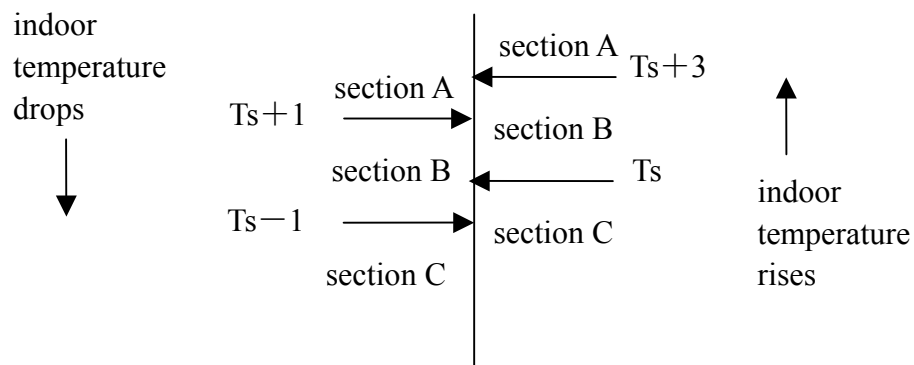

#### 5.1.4 Overloading and overheating cut-off protection (suitable for cold and heat producing machine )

Under heat producing mode, if indoor air fan is on and air compressor has been running for over 2 minutes, whenever temperature of indoor vent pipe is above  $64 \text{ } ^\circ\text{C}$ , outdoor air fan shall stop operating. And whenever temperature of indoor pipe is equal to or below  $54 \text{ } ^\circ\text{C}$ , plus outdoor air fan has stopped for over 45 seconds, outdoor air fan shall get back to operation. If temperature of indoor vent pipe is over  $67 \text{ } ^\circ\text{C}$  for more than 10 seconds, air compressor shall stop running and indoor air fan shall run in set conditions when set temperature is reached. When temperature of indoor air vent pipe is lower than  $58 \text{ } ^\circ\text{C}$  and air compressor has been out of operation for more than 3 minutes, air compressor and outdoor air fan shall get back to normal operation.

#### Heat producing current cut-off protection

After air compressor is on for over 60 seconds, CT current is higher than  $I_1 (13.5\text{A})$  and this situation lasts for 5 seconds, outdoor air fan shall stop running. After more than 45 seconds' stop for outdoor air fan and current in air compressor is lower than  $I_2 (11\text{A})$ , outdoor air fan shall get back to operation. When CT current is higher than  $I_3 (21\text{A})$  and this situation lasts for more than 3 seconds, air compressor, outdoor air fan shall stop running. After air compressor has been out of operation for 3 minutes and CT current is lower than  $18\text{A}$ , air compressor and outdoor air fan shall get back into operation.

---

### **5.1.5 Cold wind preventing in heat producing (suitable for heat and cold producing machine)**

For the first time the machine enters heat-producing mode or when the last defrosting completes, if indoor vent pipe temperature equals to or above 28 °C and lower than 38 °C, indoor air fan shall run in low speed. Whenever indoor vent pipe temperature is higher than 38 °C or air compressor has been operating for more than 4 minutes, indoor air fan shall run in set wind speed.

### **5.1.6 Blowing of left heat during heat producing (suitable for cold and heat producing machine)**

When air compressor is out of operation during heat producing or heat producing is turned off, indoor air compressor shall run in low speed for 50 minutes and then stop running.

### **5.1.7 Auto defrosting control (suitable for cold and heat producing machine)**

#### **5.1.7.1 Conditions for defrosting starts:**

a. Indoor unit enters over-loading protection and outdoor unit stops running, outdoor air fan does not enter over-heating protection after it gets back to operation for 10 minutes, accumulated operation time for air compressor is over 45 minutes, and air compressor has been running for more than 20 minutes, and indoor vent pipe temperature is lower than 43 °C.

b. Air compressor has been running for more than 20 minutes, indoor vent pipe temperature drops 1 °C for every 6 minutes and this situation appears continuously for 3 times, indoor vent pipe temperature is lower than 40 °C, and after air compressor gets back to operation for 5 minutes.

c. Accumulated time for air compressor running is over 3 hours, and air compressor has been running without break for 20 minutes, indoor vent pipe temperature is lower than 40 °C.

d. Temperature difference between indoor vent pipe temperature and indoor temperature is lower than 16 °C. and air compressor has been running without break for more than 20 minutes, accumulated running for 45 minutes.

Whenever one of the above conditions is met, defrosting shall start.

---

### **5.1.7.2 Conditions for defrosting stops**

5.1.7.2.1 Defrosting is over 9 minutes

5.1.7.2.2 CT current value is over I4(12A)

### **5.1.7.3 After defrosting starts, elements shall carry out the following actions:**

Air compressor and outdoor air fan stops running, meanwhile indoor air fan stops running. After 55 seconds, switch valve closes. After another 5 seconds, air compressor starts up.

### **5.1.7.4 Elements shall carry out the following actions after defrosting completes:**

Air compressor stops running and outdoor air fan operates in high speed immediately. After 55 seconds switch valve turns on. And after another 5 second, air compressor gets back to operation. Indoor air fan operates in cold-protection condition.

### **5.1.8 Anti-freezing function**

Indoor vent pipe temperature shall be tested after air compressor has been running for more than 9 minutes. Whenever indoor vent pipe temperature is lower than -1 °C, outdoor air fan, air compressor shall stop operating. After air compressor is stopped, air compressor and outdoor air vent shall not get back to operation only the following listed two conditions are both met.

5.1.8.1 Air compressor has been out of operating for more than 3 minutes

5.1.8.2 Indoor vent pipe temperature rises and is above 7 °C

### **5.1.9 Test of water fill and control of drainage pump**

a. Under cold producing mode (including automatically cold producing operation) and dehumidifying mode, air compressor turns on and water pump starts working. When air compressor is turned off, water pump shall be turned off after 5 minutes.

b. After water tanker is full, floater switch shall break. When controller detects this signal, pump shall get into operating. After floater replaces, water pump shall continue working for 5 minutes.

c. Whenever water full signal is detected continuously for over 5 minutes, pump lamp shall blink for alarming. Air compressor shall stop working and pump shall be on for 5 minutes with every 5 seconds break. After floater replaces, there is a time lag of 5 minutes and then the pump stops running.

---

### 5.1.10 3 minutes' protection for air compressor

After air compressor stops running, it shall not be re-operated until 3 minutes later. Whenever system is out of power during operation for less than 3 minutes, air compressor shall re-operate at least after 3 minutes when power on again.

### 5.1.11 Power cut-off memory function

When power being cut-off, repaired for faults, or operating stopped for fixing occurs during operation, the system shall re-operate under previous conditions after power is on.

P.S:

- a. Function set: press sleeping key continuously for 10 times within 5 seconds, panel beeper rings for 4 times.
- b. Memory items: operation mode, set wind speed, set temperature, wind swing situation, electrical heating situation, and health function situation.
- c. Function cancellation: press the sleeping key for 10 times using the controller and then panel beeper rings for two times.

### 5.1.12 Remote network monitoring and controlling function

Air conditioner is connected to remote controlling detector (manufactured by Haier) for tele-communication through prefabricated orifice on main board by two-core wire, and it shall carry out orders form the computer or centralized controller through remote-control detector. Meanwhile, air conditioner shall send its present operation situation and error information to remote-control detector.

The following drawing is connection of air conditioner with remote-control detector

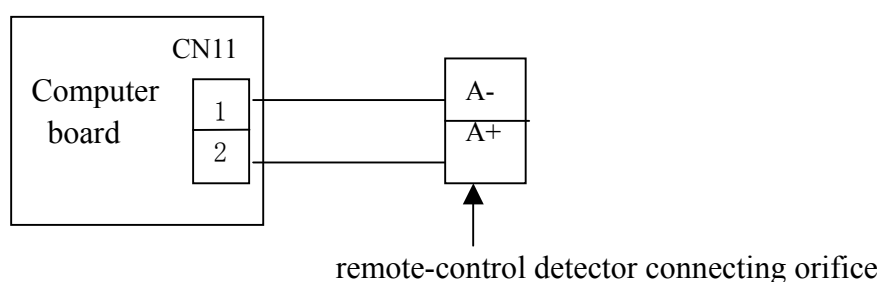

### 5.1.15 Trail run

In turning off situation, press and hold compelling key, the beeper shall ring for once and beep twice after 5 seconds. Loosen the key and enter compelled cold producing, indoor air fan shall run in high speed, and air compressor, outdoor air fan shall operate. Press compelling key again and compelled cold producing shall end.

## 5.2 Defrost operation Flow Chart

5.2.1 Model: HDU-24CA03/M(R1) HDU-28CA03/M(R1) HDU-36CA03/M(R1) HDU-42CA03/M(R1)

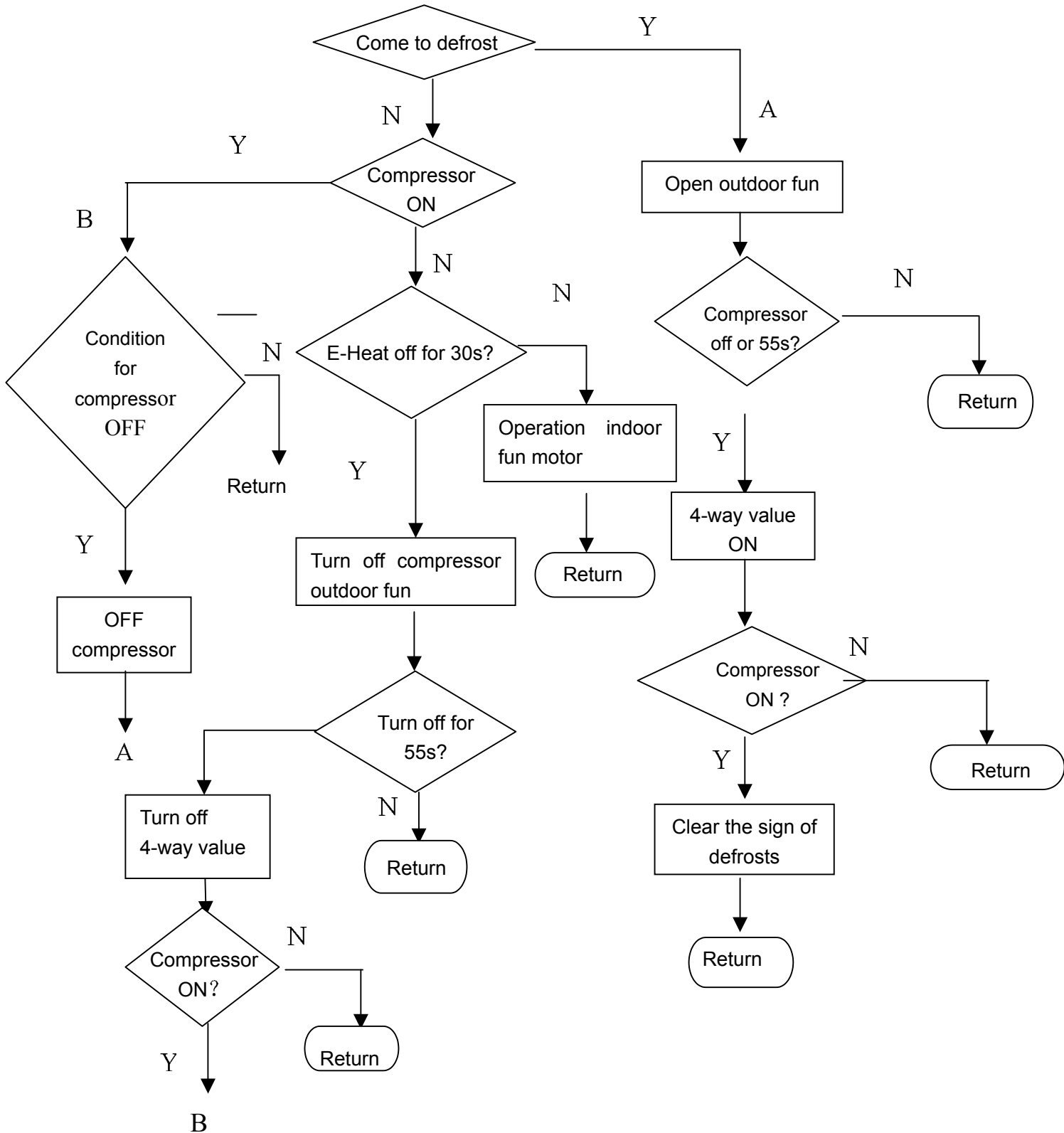

---

## 6 DIAGNOSTIC INFORMATION (TROUBLE SHOOTING)

### 6.1 Fault Codes

HDU-24CA03/M(R1) HDU-28CA03/M(R1) HDU-36CA03/M(R1) HDU-42CA03/M(R1)

No.	Code	Flash time of compressor running indicate lamp	Trouble contents (old)	Trouble contents (new)
1	E0	10	drainage system trouble	drainage system trouble
2	E1	1	indoor temperature sensor broken	indoor temperature sensor broken
3	E2	2	indoor coil temperature sensor broken	indoor coil temperature sensor broken
4	E3	3	outdoor temperature sensor broken	outdoor temperature sensor broken
5	E4	4	outdoor coil temperature sensor broken	outdoor coil temperature sensor broken
6	E5	5	over current protect limit	over current protect limit
7	E6	6	pressure protect	pressure protect
8	E7	7	communication trouble between wired remote controller and indoor unit	three phase protect
9	E8	8	communication trouble between indoor and outdoor unit	Communication trouble between wired remote controller and indoor unit
10	E9	9	three phase protect	communication trouble between indoor and outdoor unit

Indicate lamp of remote control receiver board:

Green----power lamp

Yellow----timer lamp

Red----running of compressor

Red----water pump

The faults are shown by lamp flashing or display on the remote controller

## 6.2 Trouble Shooting - Detailed for engineer

Symptom	Result of examination	Possible reason	Measures
The trouble of the indoor and outdoor board communication	Obstruction in signal S between indoor and outdoor unit	Linking assemblies are not ready	Insert the linking assemblies
	Abnormal power supply of outdoor board	Power line is not linked well	Plug in the power line
		Fuse of outdoor board is damaged	Change a new fuse
		Transformer is not linked well	Plug in the transformer
		Power supply circuit of outdoor board is in trouble	Return it to the manufacturer for service
4-way valve has no output when in heat operation	Communication indicator of indoor board does not flash	Communication circuit is in trouble	Return it to the manufacturer for service
	Leg 13 of 2003 on outdoor board has no output	2003 is damaged	Change a new 2003
	Relay JK3 on outdoor board has no output	Relay JK3 on outdoor board is damaged	Change a new relay JK3
	Relay JK3 on outdoor board has output	Socket CN6 on outdoor board and connection wire are not linked well	Link the connection wire well
		Safety unit is protecting the machine for 3 minute.	After 3 minute the machine automatically start
Compressor does not work in cool mode under the normal temperature condition		Temp. of indoor coil pipe is too low, freeze-proof protection	After the temp. of the indoor coil pipe increasing to 8°C the machine automatically start
	Leg 14 of 2003 on outdoor board has no output	2003 is damaged	Change a new 2003
	Relay JK2 on outdoor board has no output	Relay JK2 on outdoor board is damaged	Change a new relay JK2
	Relay JK2 on outdoor board has output	Socket CN7 on outdoor board and connection wire are not linked well	Link the connection wire well
		Socket CN2 on outdoor board and connection wire are not linked well	Link the connection wire well
Alarm displayed while pipe pressure is normal	Two pins of CN2 on outdoor board are both low voltage	Pressure testing circuit is in trouble	Return it to the manufacturer for service

Symptom	Result of examination	Possible reason	Measures
Compressor does not work in heat mode under the normal temperature condition.		Safety unit is protecting the machine for 3 minute.	After 3 minute the machine automatically start
		Temp. of indoor coil pipe is too high,overheat protection	After the temp. of the indoor coil pipe decreasing to 48℃ the machine automatically start.
	Leg 14 of 2003 on outdoor board has no output	2003 is damaged	Change a new 2003
	Relay JK2 on outdoor board has no output	Relay JK2 on outdoor board is damaged	Change a new relay JK2
	Relay JK2 on outdoor board has output	Socket CN7 on outdoor board and connection wire are not linked well	Link the connection wire well.
In cool mode, compressor works while outdoor fan does not work.		Temp. of indoor coil pipe is too low, freeze-proof protection	After the temp. of the indoor coil pipe increasing to 8℃ the machine automatically start.
	Leg 15 or 16 of 2003 on outdoor board has no output	2003 is damaged	Change a new 2003
	Relay JK1 or JK5 on outdoor board has no output	Relay JK1 or JK5 on outdoor board is damaged	Change new relays
	Relay on outdoor board has output	Socket CN9 on outdoor board and connection wire are not linked well	Link the connection wire well.
		Temp. of indoor coil pipe is too high,overheat protection	After the temp. of the indoor coil pipe decreasing to 48℃ the machine automatically start.
In heat mode, compressor works while outdoor fan does not work.	Leg 15 or 16 of 2003 on outdoor board has no output	2003 is damaged	Change a new 2003
	Relay JK1 or JK5 on outdoor board has no output	Relay JK1 or JK5 on outdoor board is damaged	Change new relays
	Relay on outdoor board has output	Socket CN8 on outdoor board and connection wire are not linked well	Link the connection wire well.



Symptom	Result of examination	Possible reason	Measures
Drainage pump does not discharge water when water is full.	No signal of float rising	Float itself is damaged	Change a new float
		CN11 on indoor board is not linked well	Link CN11 well
		Main chip of indoor board is damaged	Change a new indoor board
	Leg 12 of 2803 has no output	2803 is damaged	Change a new 2803
Alarm when water level is normal	CN5 on indoor board has no output	Relay JK6 is damaged	Change a new relay JK6
		CN11 on indoor board is not linked well	Link CN11 well
		Link wire of float feedback signal is obstructed	Change a new link wire
	2803 on indoor board has no output	2803 is damaged	Change a new 2803
Indoor fan does not work	Outputs of relay JK1, JK2 and JK3 are normal	CN8 on indoor board is not linked well	Link CN8 well
	2803 on indoor board has no output	2803 is damaged	Change a new 2803
Indoor fan has no low speed	Terminal COM of relay JK2 on indoor board has no voltage	Relay JK2 is damaged.	Change a new relay JK2
	Relay JK1 on indoor board has no output	Relay JK1 is damaged.	Change a new relay JK1
	Leg 17 of 2803 on indoor board has no output	2803 is damaged	Change a new 2803
	Terminal COM of relay JK1 on indoor board has no voltage	Relay JK1 is damaged.	Change a new relay JK1
Indoor fan has no mid speed	Relay JK2 on indoor board has no output	Relay JK2 is damaged.	Change a new relay JK2
	Leg 16 of 2803 on indoor board has no output	2803 is damaged	Change a new 2803
Indoor fan has no high speed	Relay JK1 on indoor board has no output	Relay JK1 is damaged	Change a new relay JK1

Symptom	Result of examination	Possible reason	Measures
No response when switch on	Power supply input of circuit board has no voltage	Power line is not linked well	Link power line well
	No voltage after passing fuse	Parts of filter circuit are damaged Fuse is damaged	Change a new computer board Change a new fuse
	The second side of transformer has no output	Transformer is not linked well or it is damaged	Link the transformer well or change a new one
Front controlling board has no response when switch on	Output of 7805 is abnormal	Power supply part of indoor board is damaged	Change a new computer board
	Power supply input of front controlling board has no voltage	Connection parts between front controlling board and indoor board is not linked well	Link the connection parts well
	+5V output is abnormal	Filter capacitor C2,C3 on power supply of display board is damaged 7805 and its input output filter capacitor are damaged	Change a new capacitor
	Reset voltage is low	Short-circuit of other circuits Reset chip T600D is damaged	Change a new computer board Change a new reset chip T600D
Buzzer is not sounded when pressing button	Has no square wave signal in both ends of buzzer	Main chip is damaged	Change a new computer board
	Has square wave signal in both ends of buzzer	Buzzer is damaged	Change a new buzzer
One or two button is blocked		Display panel is improperly installed	Properly loosen installation bolts of four circuit boards
		Joints of connection line are not linked well	Link the joints well
Front board and main board communication malfunction displays E7	Front board and main board communication line is obstructed.	Connection line is malfunction	Change new connection line
		Socket CN2 on indoor board is not linked well	Link CN2 well
		Four triode in the communication circuit may be damaged	Change a new computer board

## 7. Installation instruction

### 7.1 Installation for outdoor unit

#### <Heat Pump model/Cooling Only model >

##### ⚠ WARNING

BE SURE TO READ THESE INSTRUCTIONS CAREFULLY BEFORE BEGINNING INSTALLATION. FAILURE TO FOLLOW THESE INSTRUCTIONS COULD CAUSE SERIOUS INJURY OR DEATH, EQUIPMENT MALFUNCTION AND/OR PROPERTY DAMAGE. BE SURE TO READ INSTALLATION MANUAL FOR INDOOR UNIT WITH THIS MANUAL.

### 1. Accessories

"Edging" for protection of electric wires from an opening edge.

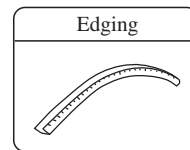

### 2. Selection of the place of installation

Select the place of installation satisfying the following conditions and, at the same time, obtain a consent from the client or user.

- Place where air circulates.
- Place free from heat radiation from other heat sources.
- Place where drain water may be discharged.
- Place where noise and hot air may not disturb the neighborhood.
- Place where there is not heavy snowfall in the winter time.
- Place where obstacles do not exist near the air inlet and air outlet .
- Place where the air outlet may not be exposed to a strong wind.
- Place surrounded at four sides are not suitable for installation. A 1m or more of overhead space is needed for the unit.
- Mount guide-louvers to place where short-circuit is a possibility.
- When installing several units, secure sufficient suction space to avoid short circuiting.

#### (1) Open space requirement around the unit

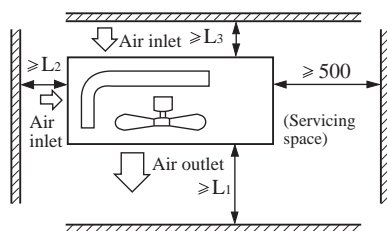

Unit: mm

Case	I	II	III
Distance			
L <sub>1</sub>	open	open	500
L <sub>2</sub>	300	0	open
L <sub>3</sub>	150	300	150

#### (2) Installation where the area with strong winds.

Install the unit so that the air outlet section of the unit must NOT be faced toward wind direction.



### 3. Installation of outdoor unit

#### (1) Installation

Fix the unit in a proper way according to the condition of a place where it is installed by referring to the following .

##### (a) Concrete foundation

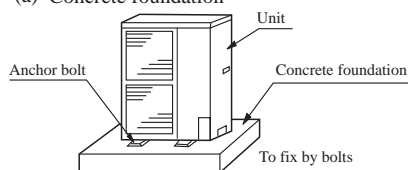

Note (1) Give enough room for the concrete foundation to fix by anchor bolts.

##### Foundation anchor

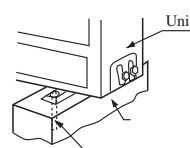

Note (1) Place the concrete foundation deep enough.

- Install the unit so that the angle of inclination must be less than 3 degrees.

## 4. Refrigerant piping

### (1) Outline piping

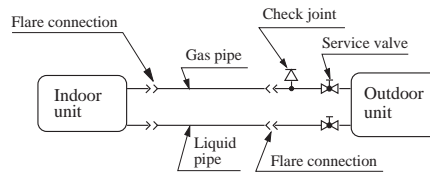

### (2) Piping size

Model	HDU-42H03/H	HDU-24H03/H HDU-28H03/H
Gas piping	Φ 19.05(3/4")x1.0mm	Φ 15.88(5/8")x1.0mm
Liquid piping	Φ 9.52(3/8")x0.8mm	Φ 9.52(3/8")x0.8mm

- Install the removed flared nuts to the pipes to be connected, then flare the pipes.

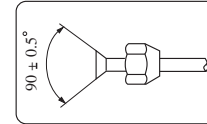

### (3) Limitations for one way piping length and vertical height difference.

- One way piping length: less than 30m (HDU-24H03/H , HDU-28H03/H).  
less than 50m (for HDU-42H03/H).
- Vertical height difference: Less than 15m (for HDU-24H03/H , HDU-28H03/H).  
less than 30m (for HDU-42H03/H).

#### Precautions for refrigerant piping

- Do not twist or crush piping.
- Be sure that no dust is mixed in piping.
- Bend piping with as wide angle as possible.
- Keep insulating both gas and liquid piping.
- Check flare-connected area for gas leakage.

### (4) Air purge

a. For HDU-24H03/H , HDU-28H03/H.

Purge air out of indoor unit and piping as shown in the Fig.

- (1) Remove the valve cap on 2-way valve in outdoor unit.
- (2) Loosen by 1-1.5 turn the flare nut of gas pipe, which is connected to 3-way valve.
- (3) Loosen the valve rod of 2-way valve by 90 degrees (use a hexagon wrench) for about 15 seconds, air will be pushed out from flare nut on gas pipe.
- (4) Open 2-way and 3-way valves using specified torque.
- (5) Tighten the caps on the valves with specified torque.
- (6) Conduct gas leakage using gas leakage detector or soap water.

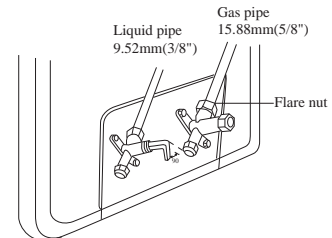

**Note:** When additional refrigerant piping is necessary, first purge air out of connecting pipe by external gas, then drive out the excessive refrigerant by purging method.

Brand new unit is charged 80g more refrigerant than spec. This is only for first installation to purge air in the indoor unit and connecting pipe.

b. For HDU-42H03/H.

Carry out the air purge of the indoor unit and refrigerant piping by vacuuming.

Procedures:

- 1) Tighten all the flare nuts of the piping on the side of indoor and outdoor units so that there is no leakage.
- 2) Carry out vacuuming from the service valve charge port with the service valves (both liquid and gas side) of the outdoor unit fully closed.
- 3) After vacuuming, remove the cap nut for the valve stem, and tighten the cap nuts (cap nuts for valve stem and charge port) with service valve (both liquid and gas) fully opened.

### (5) Method of opening and closing service valve of outdoor unit

- 1) Remove the hexagonal cap nut.
- 2) Operate the valve using a hexagonal wrench to open by left turn and to close by right turn.
- 3) Tighten the hexagonal cap nut after the piping works.

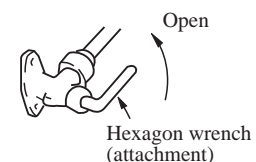

**(6) Additional charge of refrigerant**

Outdoor unit is precharged at a factory for the piping length up to 5m. Additional charge is not required up to 5m.

Model		Item	Basic refrigerant charge amount <sup>(i)</sup>	Factory charge amount of refrigerant		Additional charge amount <sup>(ii)</sup> per meter	Length that additional charge is not required	Maximum piping length
				Outdoor unit	Indoor unit			
Heat pump	HDU-42H03/H		3.44	3.52	0	0.06	5m <sup>(v)</sup> <sub>(viii)</sub>	50m
	HDU-24H03/H HDU-28H03/H		2.32	2.40	0	0.06	5m <sup>(vii)</sup> <sub>(viii)</sub>	30m

Notes (i) Basic refrigerant charge amount means refrigerant amount when refrigerant piping length is 5m.

(ii) When the refrigerant piping length exceeds the length that additional refrigerant charge is not required, charge additional refrigerant based on to the calculated amount of refrigerant per unit piping length.

**Example of additional charge amount calculation**

Calculate the additional charge amount when the piping length is 25 m.

$$(25 - 5) \times 0.06 = 1.2$$

↑                      ↑                      ↑                      ↑  
 Total length of the piping (one way) (m)    Length that additional refrigerant charge is not required (m)    Additional charge amount per 1m (kg/m)    Additional charge amount (kg)

Additional charge amount of refrigerant = 0.70kg (Calculate the amount in any case.)

If air perge with the refrigerant is forbidden at the local, please use the vacuum method (Please see the below figure)

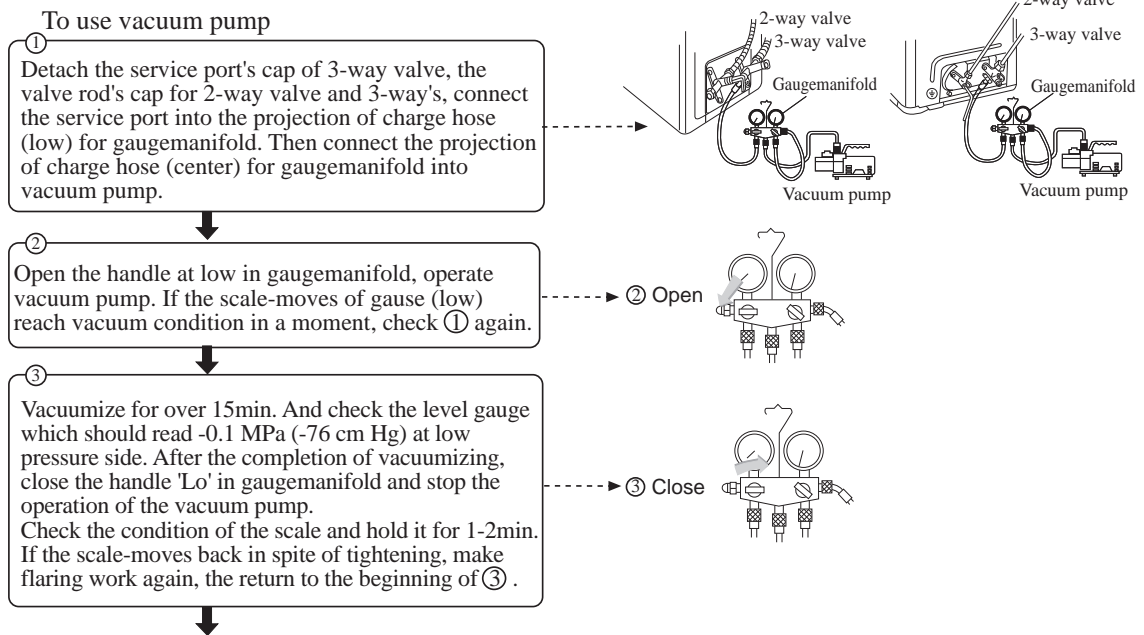

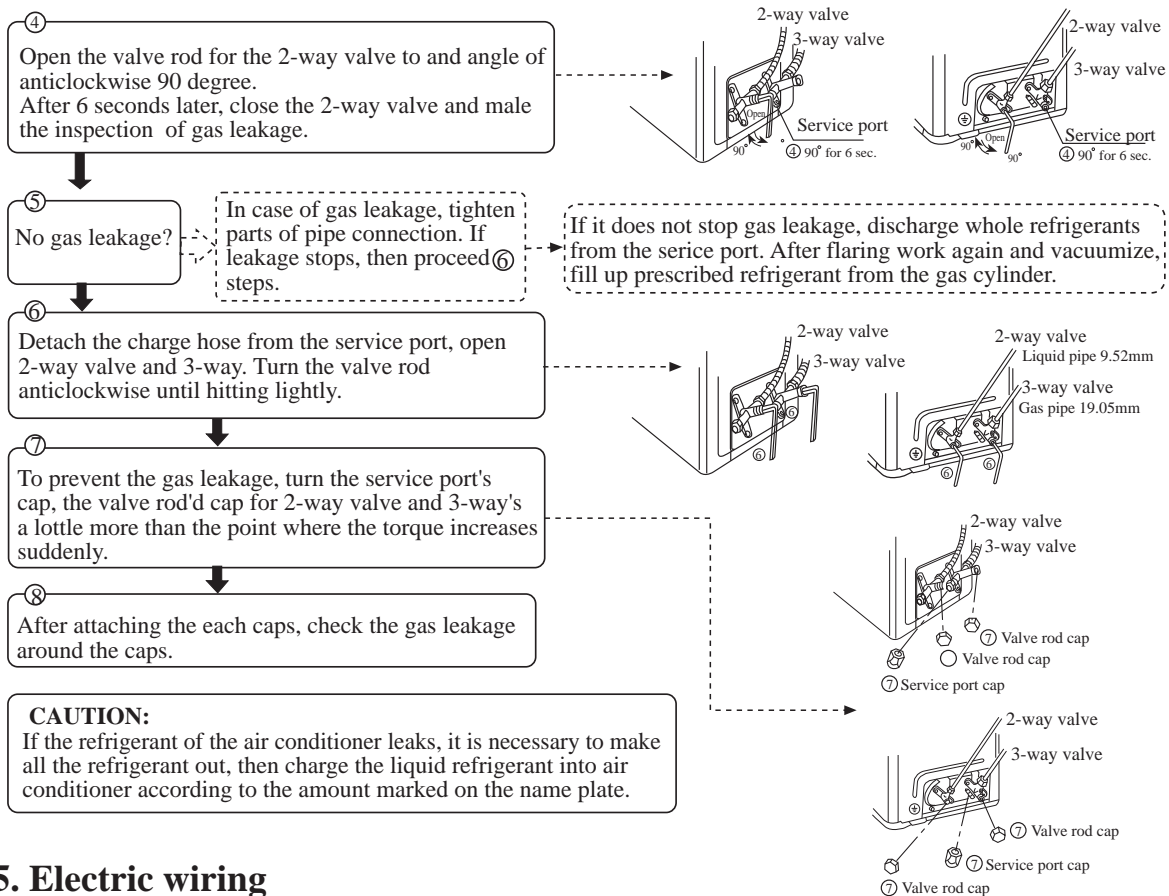

## 5. Electric wiring

### ⚠ WARNING

#### DANGER OF BODILY INJURY OR DEATH

TURN OFF ELECTRIC POWER AT CIRCUIT BREAKER OR POWER SOURCE BEFORE MAKING ANY ELECTRIC CONNECTIONS. GROUND CONNECTIONS MUST BE COMPLETED BEFORE MAKING LINE VOLTAGE CONNECTIONS.

#### (1) Selection of size of power supply and interconnecting wires.

##### Precautions for Electric wiring

- Electric wiring work should be conducted only by authorized personnel.
- Do not connect more than three wires to the terminal block. Always use round type crimped terminal lugs with insulated grip on the ends of the wires.
- Use copper conductor only.

Select wire sizes and circuit protection from table below. (This table shows 20 m length wires with less than 2% voltage drop.)

Item Model	Phase	Circuit breaker		Power source wire size (minimum)	Earth leakage breaker	
		Switch breaker (A)	Overcurrent protector rated capacity (A)		Switch breaker	Leak current
HDU-42H03/H	3	30	20	2.5mm <sup>2</sup>	30	30mA
HDU-24H03/H HDU-28H03/H	1	40	26	4.0mm <sup>2</sup>	40	30mA

## (2) Wiring connection

Make wiring to supply power to the outdoor unit, so that the power for the indoor unit is supplied by  
• and • terminals.

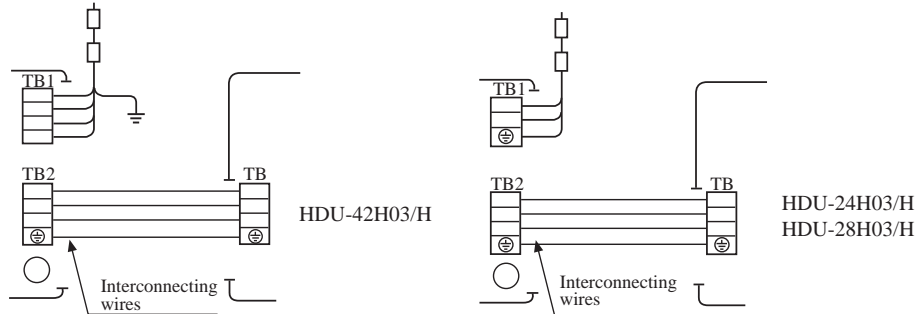

### ⚠ WARNING

DO NOT CONNECT THE NEUTRAL WIRE (N) TO (R), (S) OR (T) PHASE. INTERCONNECTING WIRES MUST BE WIRED WITH SAME SYMBOLS ON THE TERMINALS OF BOTH INDOOR AND OUTDOOR UNIT. INCORRECT WIRING CAUSE EQUIPMENT DAMAGE OR A FIRE.

## (3) Wiring procedure

- 1) Remove set screws on the side before taking off the front panel toward the direction shown in figure.
- 2) Connect wires to the terminal block correctly and fix the wires with a wire clamp equipped near by the terminal block.
- 3) Route the wires in a proper way and penetrate the wires through the opening for electric wiring on the side panel.

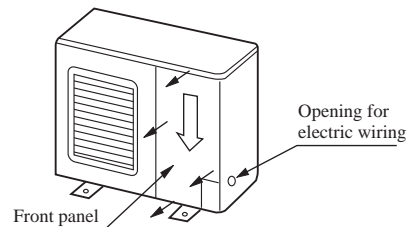

## 6. Test run

### ⚠ CAUTION

THIS UNIT WILL BE STARTED INSTANTLY WITHOUT "ON" OPERATION WHEN ELECTRIC POWER IS SUPPLIED.  
BE SURE TO EXECUTE "OFF" OPERATION BEFORE ELECTRIC POWER IS DISCONNECTED FOR SERVICING.

- This unit has a function of automatic restart system after recovering power stoppage.

### (1) Before starting test run (for all Heat pump models)

Confirm whether the power source breaker (main switch) of the unit has been turned on for over 12 hrs to energize the crankcase heater in advance of operation.

### (2) Test run

Run the unit continuously for about 30 minutes, and check the following.

- Suction pressure at check joint of service valve for gas pipe.
- Discharge pressure at check joint on the compressor discharge pipe.
- Temperature difference between return air and supply air for indoor unit.

## 7.2 Installation for indoor unit

### Safety precautions

- Please read these "Safety Precautions" first then accurately execute the installation work.
- Though the precautionary points indicated herein are divided under two headings, **⚠ WARNING** and **⚠ CAUTION**, those points which are related to the strong possibility of an installation done in error resulting in death or serious injury are listed in the **⚠ WARNING** section. However, there is also a possibility of serious consequences in relationship to the points listed in the **⚠ CAUTION** section as well. In either case, important safety related information is indicated, so by all means, properly observe all that is mentioned.
- After completing the installation, along with confirming that no abnormalities were seen from the operation tests, please explain operating methods as well as maintenance methods to the user (customer) of this equipment, based on the owner's manual.  
Moreover, ask the customer to keep this sheet together with the owner's manual.

#### **⚠ WARNING**

- This system should be applied to places as office, restaurant, residence and the like. Application to inferior environment such as engineering shop could cause equipment malfunction.
- Please entrust installation to either the company which sold you the equipment or to a professional contractor. Defects from improper installations can be the cause of water leakage, electric shocks and fires.
- Execute the installation accurately, based on following the installation manual. Again, improper installations can result in water leakage, electric shocks and fires.
- When a large air-conditioning system is installed to a small room, it is necessary to have a prior planned countermeasure for the rare case of a refrigerant leakage, to prevent the exceeding of threshold concentration. In regards to preparing this countermeasure, consult with the company from which you purchased the equipment, and make the installation accordingly. In the rare event that a refrigerant leakage and exceeding of threshold concentration does occur, there is the danger of a resultant oxygen deficiency accident.
- For installation, confirm that the installation site can sufficiently support heavy weight. When strength is insufficient, injury can result from a falling of the unit.
- Execute the prescribed installation construction to prepare for earthquakes and the strong winds of typhoons and hurricanes, etc. Improper installations can result in accidents due to a violent falling over of the unit.
- For electrical work, please see that a licensed electrician executes the work while following the safety standards related to electrical equipment, and local regulations as well as the installation instructions, and that only exclusive use circuits are used.  
Insufficient power source circuit capacity and defective installation execution can be the cause of electric shocks and fires.
- Accurately connect wiring using the proper cable, and insure that the external force of the cable is not conducted to the terminal connection part, through properly securing it. Improper connection or securing can result in heat generation or fire.
- Take care that wiring does not rise upward, and accurately install the lid/service panel. Its improper installation can also result in heat generation or fire.
- When setting up or moving the location of the air conditioner, do not mix air etc. or anything other than the designated refrigerant (R22) within the refrigeration cycle.  
Rupture and injury caused by abnormal high pressure can result from such mixing.
- Always use accessory parts and authorized parts for installation construction. Using parts not authorized by this company can result in water leakage, electric shock, fire and refrigerant leakage.

#### **⚠ CAUTION**

- Execute proper grounding. Do not connect the ground wire to a gas pipe, water pipe, lightning rod or a telephone ground wire. Improper placement of ground wires can result in electric shock.
- The installation of an earth leakage breaker is necessary depending on the established location of the unit. Not installing an earth leakage breaker may result in electric shock.
- Do not install the unit where there is a concern about leakage of combustible gas.  
The rare event of leaked gas collecting around the unit could result in an outbreak of fire.
- For the drain pipe, follow the installation manual to insure that it allows proper drainage and thermally insulate it to prevent condensation. Inadequate plumbing can result in water leakage and water damage to interior items.



## ⚠ NOTICE

All Wiring of this installation must comply with NATIONAL, STATE AND LOCAL REGULATIONS. These instructions do not cover all variations for every kind of installation circumstance. Should further information be desired or should particular problems occur, the matter should be referred to your local distributor.

## ⚠ WARNING

BE SURE TO READ THESE INSTRUCTIONS CAREFULLY BEFORE BEGINNING INSTALLATION. FAILURE TO FOLLOW THESE INSTRUCTIONS COULD CAUSE SERIOUS INJURY OR DEATH, EQUIPMENT MALFUNCTION AND/OR PROPERTY DAMAGE.

### 1. Before installation [Before finishing installation, do not throw the attached parts installation needs]

- Confirm the way to move the unit to the installation place.
- Before moving the unit to the installation place, do not remove their packages.  
When have to remove the package, use a soft material or protection board with rope to lift the unit assembly to avoid unit damage or bumping a scrape.

### 2. Choose installation place

#### (1) The chosen installation place should meet the following requirements and get the user's consent.

- Place ensures ideal airflow distribution.
- The passage of airflow has no obstacles.
- When importing outside air, it should be imported directly from outdoors. (if the pipe can not be extended, it also can not be imported from top)
- Place ensures enough space for maintenance.
- The pipe length between indoor and outdoor unit is in the permitted limit (referring to outdoor unit installation part).
- The indoor unit, outdoor unit, electric wire and connection wire is at least 1m away from television and radio. This is to avoid the image disturbance and noise caused by the above-mentioned home appliance. (Even if 1m away, if the electromagnetic wave is too strong, it can also cause noise.)

#### (2) The height of ceiling

- The indoor unit can install on the ceiling, which height is no more than 3m.

#### (3) Install and use the hoisting screw. Check if the installation place can bear the weight of unit assembly.

- If not certain, strengthen it before install the unit.

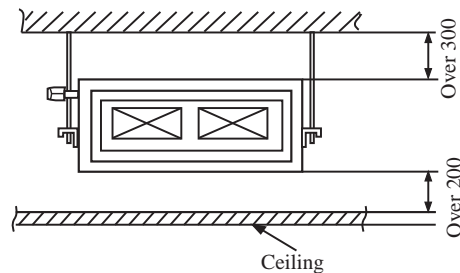
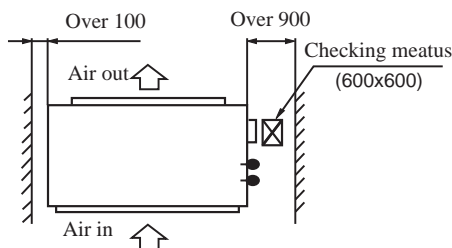

### 3. Preparation before installation

#### (1) The position relation among hoisting screw (unit: mm)

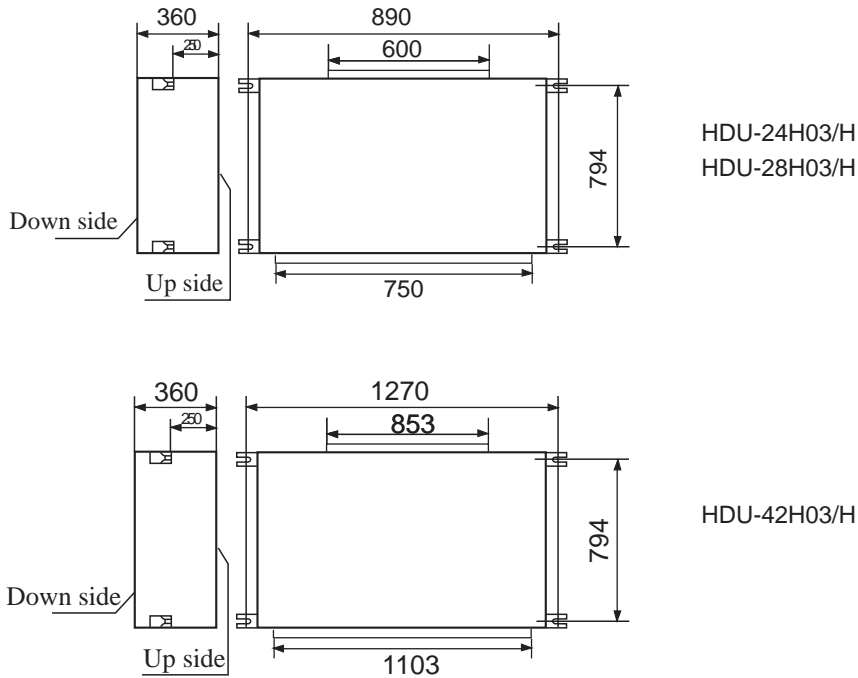

#### (2) If necessary, cut the opening installation and checking needed on the ceiling. (If has ceiling)

- Before installation, finish the preparation work of all the pipes (refrigerant, drainage) and wire (wire controller connection wire, indoor and outdoor unit connection wire) of indoor unit, so that after installation, they can be immediately connected with outdoor unit.
- Cut the opening on the ceiling. Maybe it needs to strengthen the ceiling to keep the ceiling even and flat and prevent the ceiling from vibration. For details, please consult to the builder.

#### (3) Hanger bolts installation

- Use care of the piping direction when the unit is installed.

(Use M10 screw bolt)

In order to bear the weight of the unit, for existed ceiling, using foundation screw bolt, for new ceiling, using burying embedded screw bolt, burying screw bolt or spot supplied other parts.

Before going on installation, adjust the gaps with ceiling.

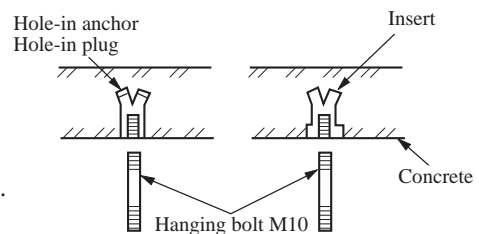

#### 4. Installation of indoor unit

- Fix the indoor unit to the hanger bolts.  
If required, it is possible to suspend the unit to the beam, etc.  
Directly by use of the bolts without using the hanger bolts.

#### Note

When the dimensions of main unit and ceiling holes does not match, it can be adjusted with the slot holes of hanging bracket.

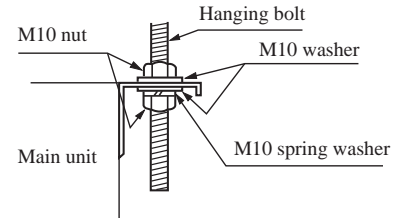

#### Adjusting to the levelness

- Adjust the out-of levelness using a level or by the following method.
  - Make adjustment so that the relation between the lower surface of the unit proper and water level in the hose becomes as given below.

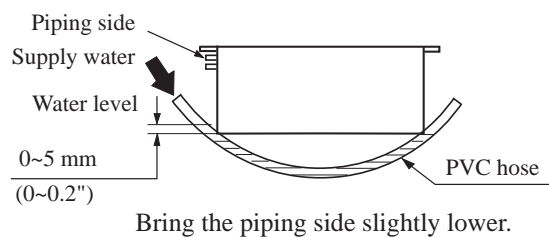

- Unless the adjustment to the levelness is made properly, malfunctioning or failure of the float switch may occur.

#### 5. Drain Piping

- Drain piping should always be in a downhill grade (1/50~1/100) and avoid riding across an elevation or making traps.

##### • Good piping

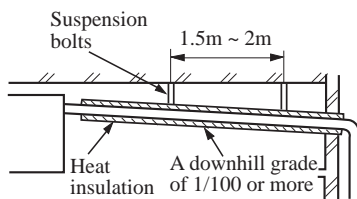

##### • Improper piping

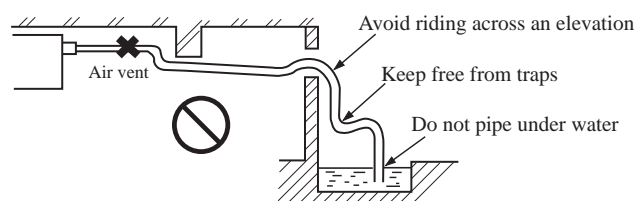

- When connecting the drain pipe to unit, pay sufficient attention not to apply excess force to the piping on the unit side. Also, fix the piping at a point as close as possible to the unit.

- For drain pipe, use hard PVC general purpose pipe VP-25(I.D.1") which can be purchased locally. When connecting, insert a PVC pipe end securely into the drain socket before tightening securely using the attached drain hose and clamp. Adhesive must not be used connection of the drain socket and drain hose (accessory).

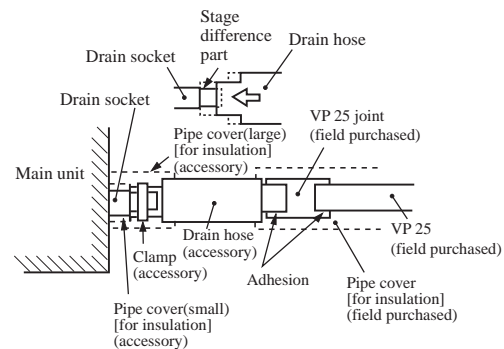

- (d) When constructing drain piping for several units, position the common pipe about 100 mm below the drain outlet of each unit as shown in the sketch. Use VP-30(1 1/4") or thicker pipe for this purpose.

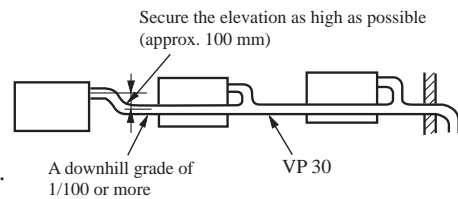

- (e) The stiff PVC pipe put indoor side should be heat insulated.
- (f) Avoid putting the outlet of drain hose in the places with irritant gas generated. Do not insert the drain hose directly into drainage, where the gas with sulfur may be generated.

(g) Backwater bend

Because the drain spout is at the position, which negative pressure may occur. So with the rise of water level in the drain pan, water leakage may occur. In order to prevent water leakage, we designed a backwater bend.

The structure of backwater bend should be able to be cleaned. As the below figure shown, use T type joint. The backwater bend is set near the air conditioner.

- As figure shown, set a backwater bend in the middle of drain hose.

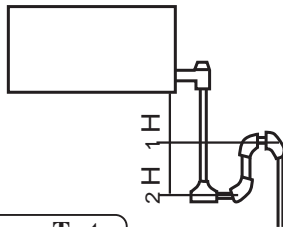

$H1=100\text{mm}$  or the static pressure of air sending motor  
 $H2=1/2H1$  (or between 50~100mm)

**Drainage Test**

- ① Conduct a drainage test after completion of the electrical work.
- ② During the trial, make sure that drain flows properly through the piping and that no water leaks from connections.
- ③ In case of a new building, conduct the test before it is furnished with the ceiling.
- ④ Be sure to conduct this test even when the unit is installed in the heating season.

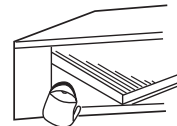

**Procedures**

- ① Supply about 1000 cc of water to the unit through the air outlet using a feed water pump.
- ② Check the drain while cooling operation.

**6. Installation of air suction and discharging duct**

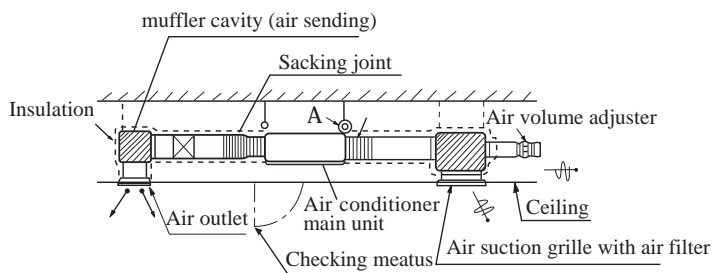

Enlarging chart of profile chart A  
 Vibration resistance hook

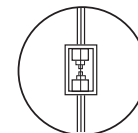

Please consult the after-sales service worker of Haier Air Conditioner for the choosing and installation of suction inlet, suction duct, discharging outlet and discharging duct. Calculating the design drawing and outer static pressure, and choose the discharging duct with proper length and shape.

- The length difference among every duct is limited below 2:1.
- Reduce the length of duct as possible as can.
- Reduce the amount of bend as possible as can.
- Use heat insulation material to bind and seal the part connecting main unit and the flare part of air discharging duct. Perform duct installation work, before the fitment of ceiling.

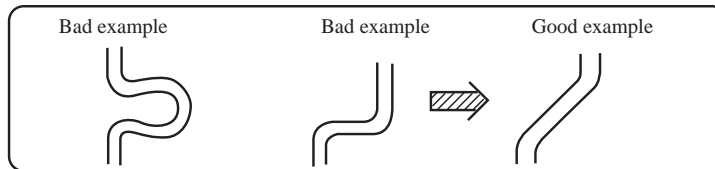

### 7. Calculation method of the dimension of the simple quadrate air duct

Presuming the unit length friction impedance of the duct is 1Pa/m, when the dimension of one side of the air duct is fixed as 250mm, as shown below:

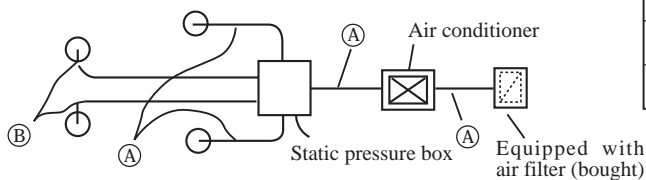

	Air volume	Duct(mmxmm)	Air volume	Duct(mmxmm)
Ⓐ	2400m <sup>3</sup> /h (40m <sup>3</sup> /min)	250x560	1200m <sup>3</sup> /h (20m <sup>3</sup> /min)	250x310
Ⓑ	600m <sup>3</sup> /h (10m <sup>3</sup> /min)	250x190	300m <sup>3</sup> /h (5m <sup>3</sup> /min)	250x120
		HDU-42H03/H		HDU-24H03/H HDU-28H03/H

- The calculation of duct resistance (the simple calculation is as follow table)

Straight part	Calculate as per 1m length 1Pa, 1Pa/m
Bend part	Each bend takes as a3~4m long straight duct
Air out part	Calculate as 25Pa
Static pressure box	Calculate as 50Pa/each
Air inlet grille (with air filter)	Calculate as 40Pa/each

- The chosen chart of simple duct

Note: 1Pa/m=0.1mmAg/m

Air volume m <sup>3</sup> /h(m <sup>3</sup> /n)	Shape	Square duct
	Item	Dimension
		(mmxmm)
100		250 x 60
200		250 x 90
300		250 x 120
400		250 x 140
500		250 x 170
600(10)		250 x 190
800		250 x 230
1,000		250 x 270
1,200(20)		250 x 310
1,400		250 x 350
1,600		250 x 390

Air volume m <sup>3</sup> /h(m <sup>3</sup> /n)	Shape	Square duct
	Item	Dimension
		(mmxmm)
1,800(30)		250 x 430
2000		250 x 470
2400		250 x 560
3,000(50)		250 x 650
3,500		250 x 740
4,000		250 x 830
4,500		250 x 920
5,000		250 x 1000
5,500		250 x 1090
6,000(100)		250 x 1180

## 8. The attentive matters in installation of air suction and discharging duct

- Recommend to use anti-frost and sound-absorbing duct. (locally bought)
- The duct installation work should be finished before the fitment of ceiling.
- The duct must be heat insulated.
- The specific air-discharging outlet should be installed at the place where the airflow can be reasonably distributed.
- The surface should leave a checking meatus for checking and maintenance.

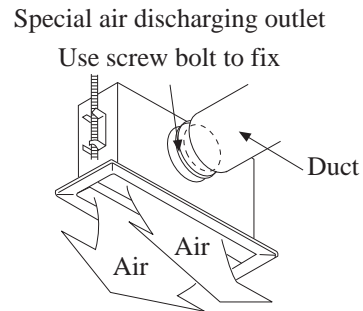

## 9. The examples of improper installation

- Do not use air in duct and take the ceiling inner side instead. The result is because of the irregular outer air mass, strong wind and sunshine, the humidity is increased.
- There may be water drop on the outside of duct. For cement and other new constructions, even if not taking ceiling inner side as duct, the humidity will also be so high. At this time, use glass fiber to perform heat preservation to the whole. (use iron net to bind the glass fiber)
- Maybe exceeding the unit operation limit (for example: when indoor dry bulb temperature is 35 ℃, wet bulb temperature 24 ℃), it may lead to overload of compressor.
- Affected by the capacity of air discharging fan, the strong wind in the outer duct and wind direction, when unit air sending volume exceeds the limit, the discharged water of heat exchanger will overflow, leading to water leakage.

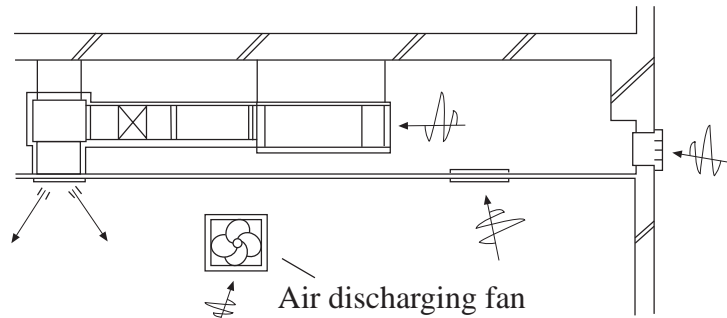

Improper example

## 10. The operation method of fan controller

Through the fan controller switch in the electric box, the air volume of this unit can be continuously adjusted.

It is unnecessary to adjust air volume through the duct side wind level (unit outside static adjustment).

The air volume set should be in the operation air volume range.

Figure I shows the position of fan controller in the electric box and operation method.

After finishing the electric work, perform test run. According to the main points in Figure II making the chosen switch No. accordant. And confirm if it reaches the needed air volume.

### Note:

- 1) When operating the fan controller, it is possible to touch the electric charging part, so do cut off the power supply.
- 2) Do not set the dial at the position less than 1.
- 3) The figure circled in Figure II indicate the capacity number of fan controller. The non-listed capacity number may exceed the permitted operation capacity range, so it is impossible to operate.
- 4) When delivering from factory, the capacity number of fan controller is set at “No.5”.

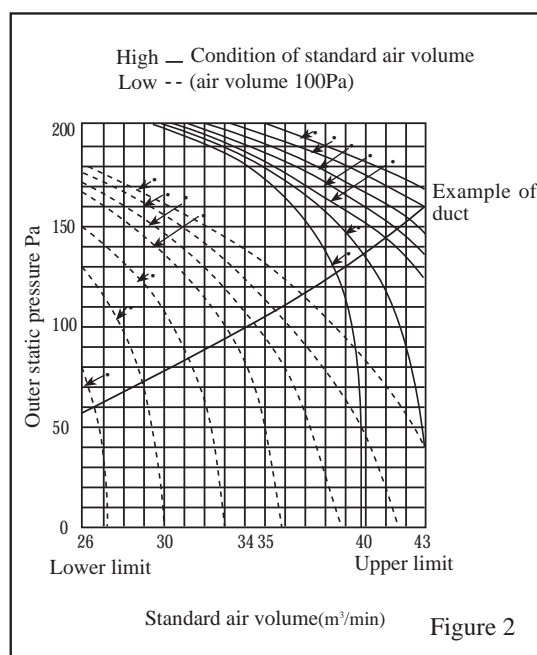
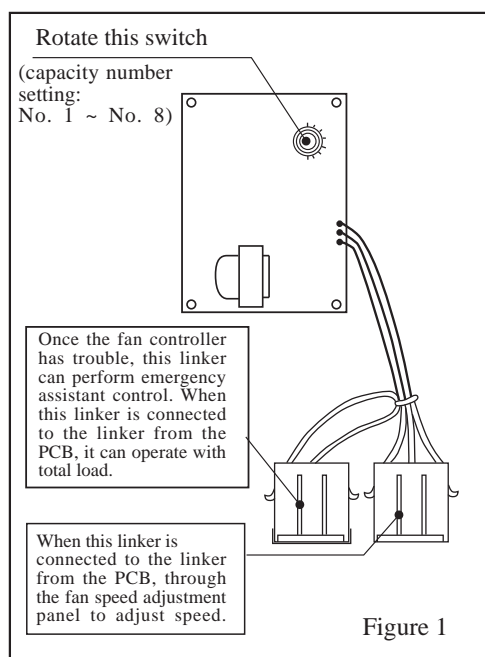

### ● The example of the method of choosing capacity number:

- 1) If the unit is in high-speed operation, needing take outer static pressure is 180Pa in capacity air volume  $34\text{m}^3/\text{min}$  as working condition point, according to Figure II “The characteristic chart of air volume”, the capacity number of fan controller is No. 2.
- 2) If the unit is in low speed operation, needing take outer static pressure is 60Pa in capacity air volume  $32\text{m}^3/\text{min}$  as working condition point, according to Figure II “The characteristic chart of air volume”, the capacity number of fan controller is No. 4.

## 11. Refrigerant pipe

[The air side pipe, liquid side pipe must be faithfully heat insulated, if no heat insulation, it may cause water leakage.]

- The outdoor unit has been charged with refrigerant.
- When connect the pipe to the unit or dismantling the pipe from the unit, please follow the figure shown, use spanner and torque spanner together.
- When connect cone nut, the inner side and outside of cone nut should paste with refrigerant oil. Use hand to twist 3-4 rings, then fasten with spanner.
- Referring to Table I to confirm the fasten torque. (too tight may damage nut leading to leakage)
- Check if the connection pipe leaks, then do heat insulation treatment, as below figure shown.
- Only use seal cushion to bind the joint part of air pipe and heat insulation parts.

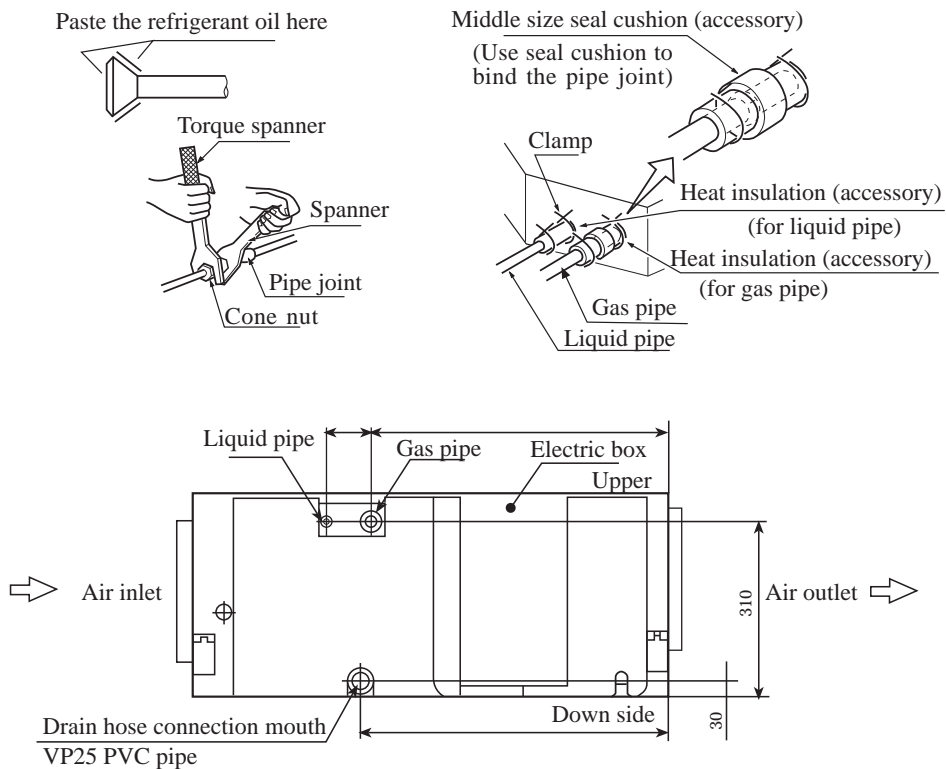

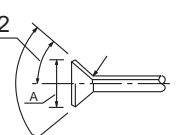
Specification of pipe (mm)	Tighten torque	Cone dimension A (mm)	Cone
Φ 9.52	3270~3990 N·cm (333~407 kgf·cm)	12.0~12.4	$45^\circ \pm 2$ $90^\circ \pm 0.5$ 
Φ 15.88	9720~11860 N·cm (990~1210 kgf·cm)	22.9~23.3	



## Other instruction

### 1. Power supply

- The air conditioner must use a special power circuit. The user should provide by himself with special switch (25A~30A), grounding wire. The wiring should be done by a qualified electrician according to the wiring rules specified by national standard
- An creepage breaker should be installed.
- The grounding wire and null wire of the power cord should be strictly separated. It is incorrect to connect the null wire with grounding wire.

### 2. Cut and flaring method

Use pipe cutter to cut the pipe, the burrs must be removed.  
After inserting the flarer, perform flared nut.

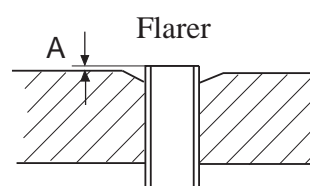

	Pipe diameter	Dimension A (mm)
Liquid pipe	$\phi$ 9.52mm (3/8")	1.0-1.2
Gas pipe	$\phi$ 19.05mm (3/4")	1.4-2.2
Gas pipe	$\phi$ 15.88mm (5/8")	1.4-2.2

Correct	Incorrect				
	Slant	Broken	Burrs	Uncompleted	Too long

### Test run

The following items must be noticed carefully during installation. After finishing installation, performing checking.

After installing the refrigerant pipe, drain hose and electric wire properly, perform test run to ensure the system not have trouble.

#### Test run

- (1) Open the stop valve of gas pipe.
- (2) Open the stop valve of liquid pipe.
- (3) Press ON/OFF button to start operation, use wire controller to set to Cooling operation.
- (4) Confirm the function of the unit according this manual.

## 8. Exploded Views & Part Lists

model: indoor unit of HDU-24H03/H HDU-28H03/H

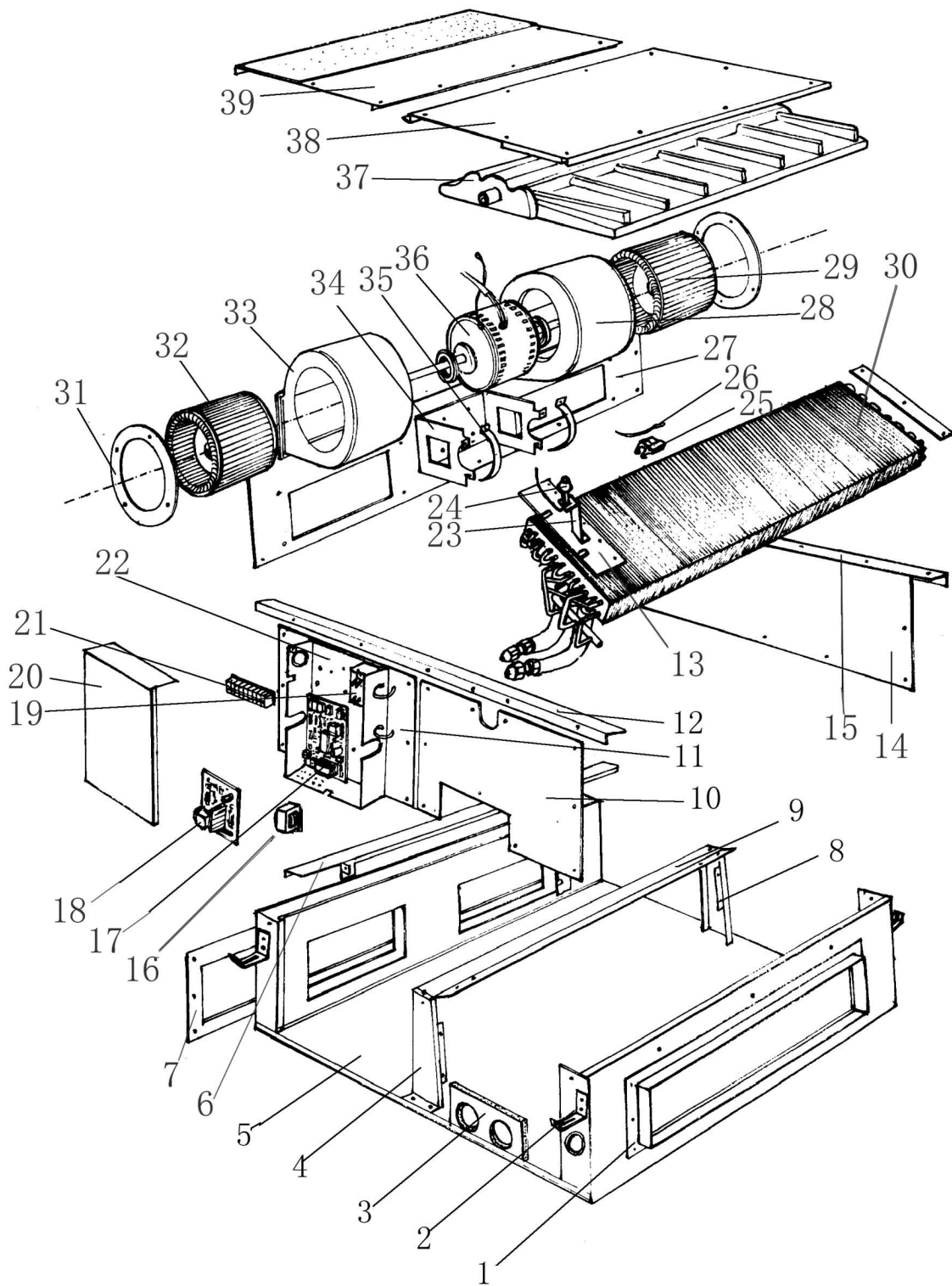

INDOOR UNIT PART LIST OF HDU-24H03/H HDU-28H03/H

No.	Name of parts	Part specialized code	QTY.
1	connection frame of inlet air	0010100506	1
2	hanging	001A13011049	4
3	boarding assy. Of liquid pipe	0010800288	1
4	evaporator brack 1	001A13011068	1
5	bottom plate assy.	0010100502	1
6	fix slot assy.	0010100511	1
7	air discharge framework	0010100503	1
8	evaporator brack 2	001A13011069	1
9	evaporator fixing plate 1	0010100504	1
10	cover board assy. 1	0010800284	1
11	cover board assy. 2	0010800285	1
12	fix tendon assy. 1	0010800282	1
13	evaporator fixing plate 3	0010800290	1
14	cover board assy.3	0010800286	1
15	fix tendon assy. 2	0010800283	1
16	transformer	001A3800141	1
17	PCB	0010400132	1
18	fan speed adjusting board	001A3300352	1
19	fan motor capacitor	001A3600254	1
20	electrical box cover	0010850004	1
21	termianl block	001A4000151	1
22	electrical box assy.	0010800399	1
23	bracket of floater	001A13011050	1
24	float switch	001A3400160	1
25	sensor bracket	001A1436026	1
26	ambient temp. sensor	001A3900006	1
27	supporting plate	001A1101236	1
28	snail shell 2	001A13011043	1
29	fan 2	001A2301105	1
30	evaporator assy.	0010750004	1
31	hermitic circle of snail shell	001A13011044	2
32	fan 1	001A2301104	1
33	snail shell 1	001A13011042	1
34	motor bracket	001A13011039	1
35	motor fixing bolt	001A13011045	2
36	motor	001A3000290	1
37	drain pan assy.	0010201091	1
38	guarding plate assy.2	0010100500	1
39	guarding plate assy.1	0010100498	1

model: outdoor unit for HDU-24H03/H HDU-28H03/H

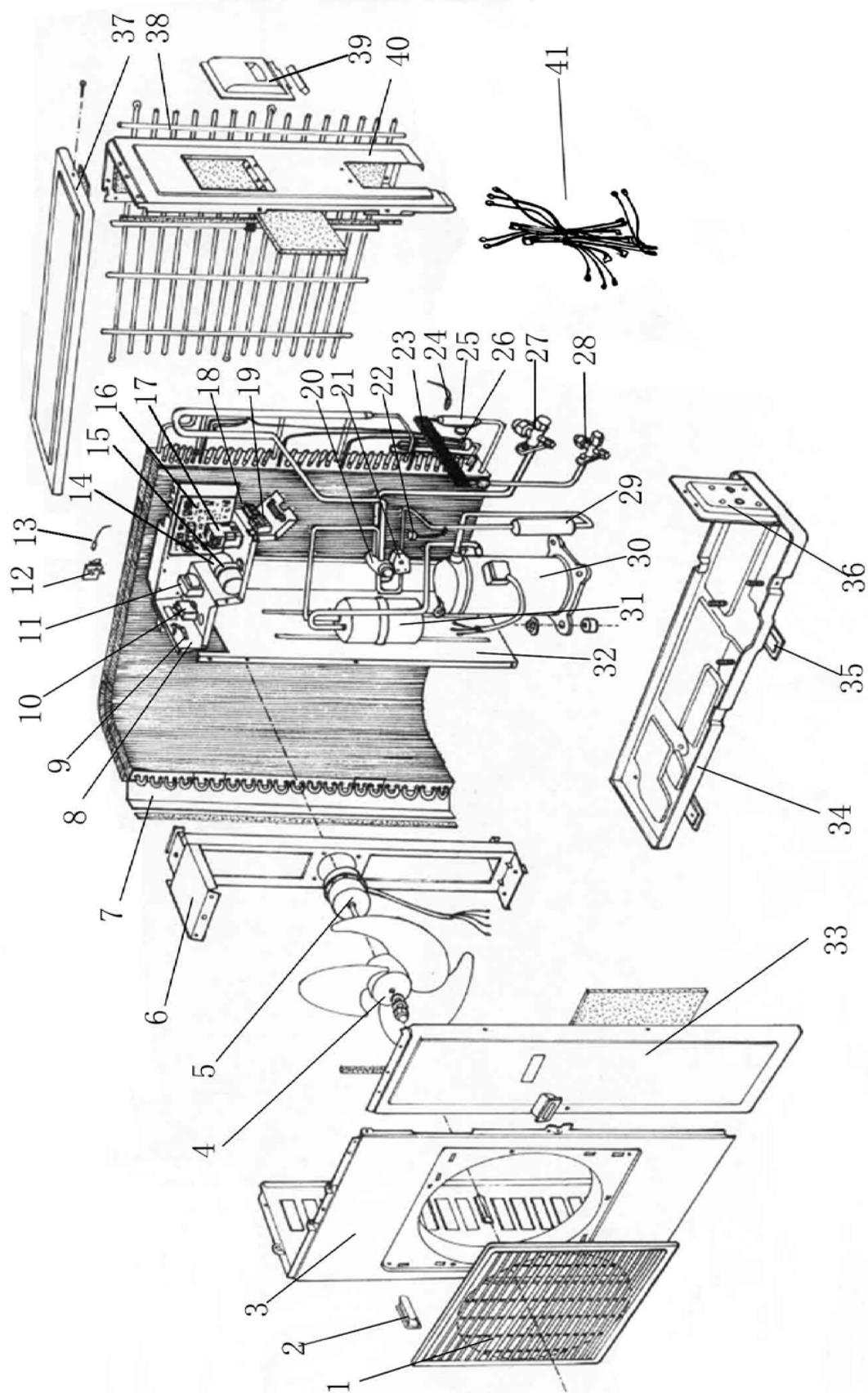

OUTDOOR UNIT PART LIST OF HDU-24H03/H HDU-28H03/H

No.	Name of parts	Part specialized code	QTY.
1	Front grille	001A1236028	1
2	handle	001A1436160	2
3	Front panel	001A0100261	1
4	Axial fan	001A5402022	1
5	Fan motor	001A3000082	1
6	Bracket for fan motor	001A0100266	1
7	Condenser assy.	001A0400119	1
8	Electric box	001A1301453	1
9	cable clamp	001A5745009	1
10	Capacitor for fan motor	001A3600018	1
11	Resumable transformer	001A3800141	1
12	clip for sensor	001A5736055	1
13	temp. Sensor (Pipe & environment)	001A3900153	1
14	Capacitor for compressor	001A3600030	1
15	Capacitor clamp	0010100001	1
16	outdoor PCB	0010400212	1
17	AC contactor	001A3900161	1
18	Terminal block	001A4000151	1
19	electrical source connection block	001A4000110	1
20	4-way valve	001A2500081	
21	coil of 4-way valve	001A2500076	1
22	High pressure switch	001A3400138	1
23	capillary	0010751180	1
25	filter	001A2411024	1
26	Tube assy.	001A0500461	1
27	3-way stop valve	001A2500083	1
28	2-way stop valve	001A2500082	1
29	muffle	001A2111912	1
30	Compressor	0010751129	1
31	Accumulator	0010751125	1
32	Partition plate	001A0100350	1
33	Front panel	001A0100524	1
34	Bottom cover assy.	001A0100351	1
35	branch triby	001A1301117	1
36	Valve pedestal	001A1301506	1
37	Top cover assy.	001A0100264	1
38	Back grille	001A0100109	1
39	Junction box	001A0100394	1
40	Slide plate(right)	001A0100390	1
41	wire assy.	001A4400511	1

model: indoor unit for HDU-42H03/H

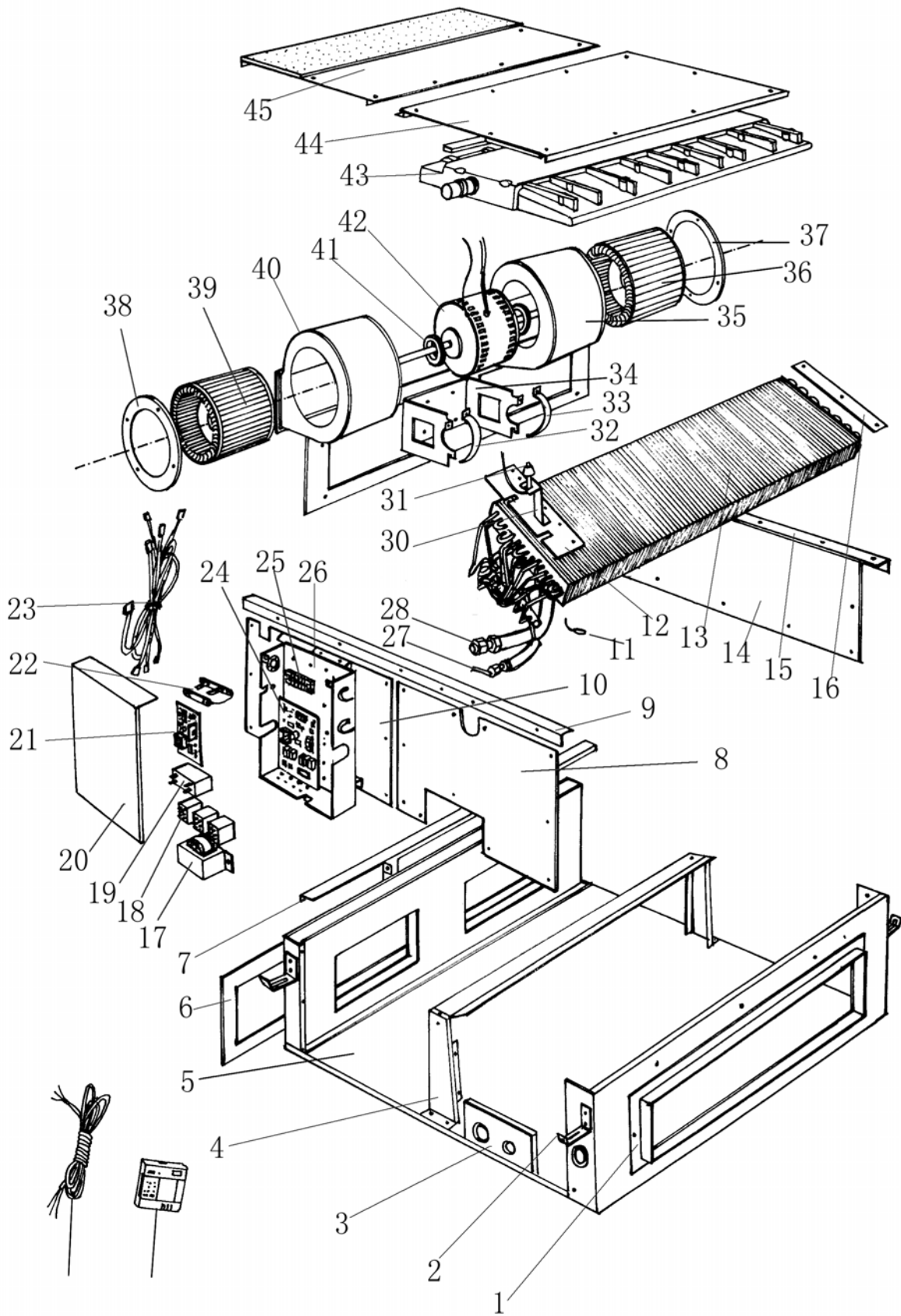

INDOOR UNIT PART LIST OF HDU-42H03/H			
No.	Name of parts	Part specialized code	QTY.
1	air inlet frame assy.	001A01001000	1
2	hanging	001A13011049	4
3	boarding assy. Of liquid pipe	0010800288	1
4	fix slot assy.	001A0100999	1
5	bottom plate assy.	001A01001002	1
6	air discharge framework	001A1301205	1
7	wiring clap		1
8	cover plate assy. 1	0010800284	1
9	fix tendon assy. 1	0010800282	1
10	cover plate assy. 2	0010800285	1
11	float braket	001A13011050	1
12	evaporator fixing plate 3	0010800290	1
13	heat exchanger assy.	0010701072	1
14	cover plate assy. 3	0010800286	1
15	fix tendon assy. 2	0010800283	1
16	evaporator fixing plate 2	0010800289	1
17	transformer	001A3800141	1
18	relay SCL-DPDT-C1	0010400298	3
19	capacitor	001A3600254	1
20	cover of electrical box	001A13011035	1
21	fan speed adjusting board	001A3300352	1
22	press clip	001A5745116	1
23	wiring harness	001A4400755	1
24	indoor PCB	0010400132	1
25	terminal block	001A4000151	1
26	electrical box	001A13011036	1
27	liquid inlet pipe assy.	0010701050	1
28	air return pipe assy.	0010700693	1
30	evaporator fixing plate 3	0010800290	1
31	float switch	001A3400160	1
32	motor hold	001A13011045	1
33	motor hold	001A13011045	1
34	motor bracket	001A13011039	1
35	snail shell 1	001A13011040	1
36	fan 1	001A2301102	1
37	hermitic circle of snail shell	001A13011044	1
38	hermitic circle of snail shell	001A13011044	1
39	fan 2	001A2301103	1
40	snail shell 2	001A13011041	1
41	spring washer M4	001A5401035	1
42	indoor motor	001A3000291	1
43	drain pan assy.	0010800329	1
44	guard plate assy. 1	0010800280	1
45	guard plate assy. 2	0010800281	1

model: outdoor unit for HDU-42H03/H

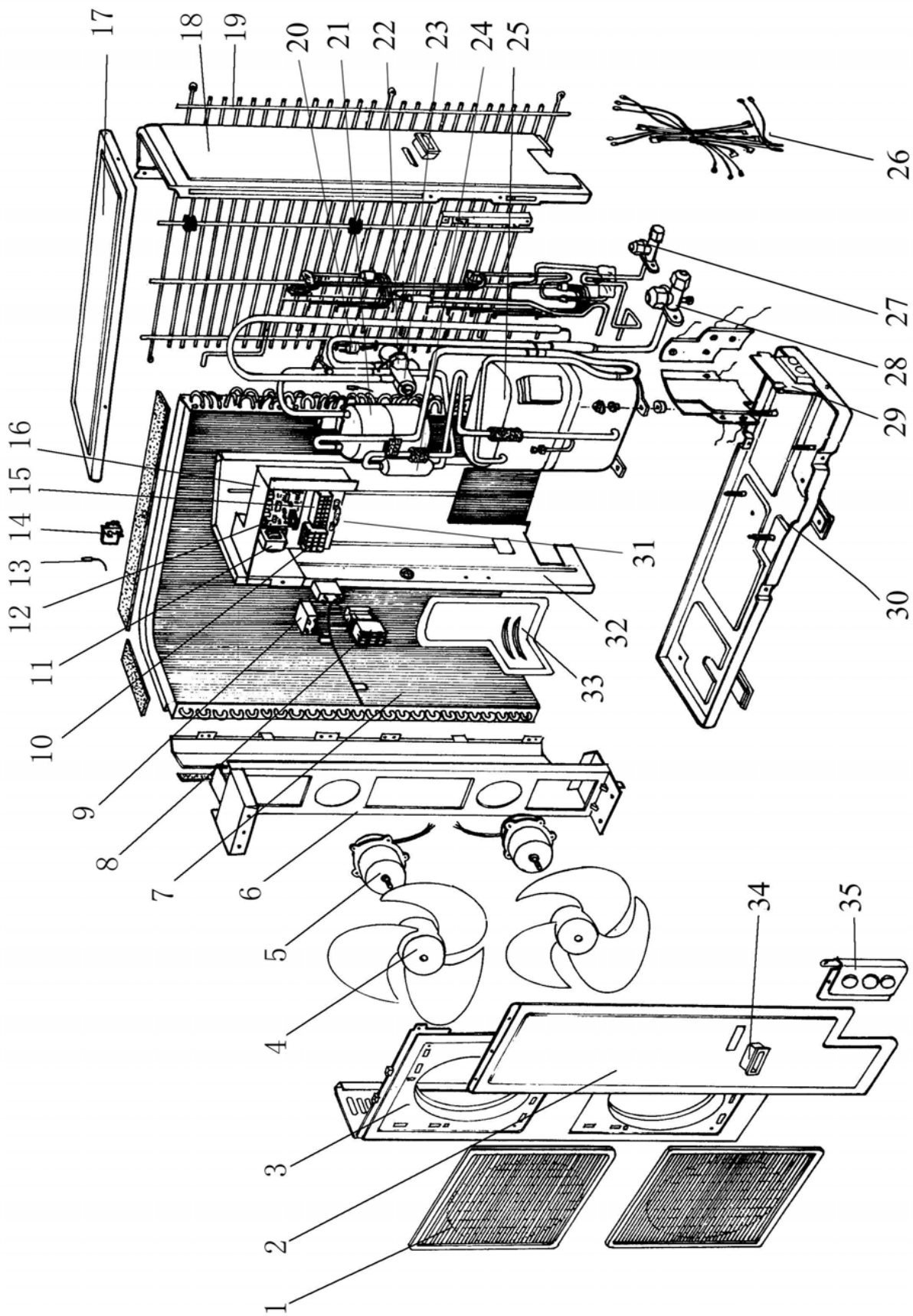



OUTDOOR UNIT PART LIST OF HDU-42H03/H

No.	Name of parts	Part specialized code	QTY.
1	Front grille	001A0100122	2
2	service panel assy	001A1301707	1
3	Front panel	001A1301640	2
4	Axial fan	001A5402022	2
5	Fan motor	001A3000244	2
6	Bracket for fan motor	001A0100740	1
7	Condenser assy.	001A0400173	1
8	AC contactor	001A3900161	1
9	Capacitor for fan motor	002A3600018	2
10	connection block	001A4000011	1
11	Resumable transformer	001A03800141	1
12	outdoor PCB	0010400214	1
13	temp. Sensor (Pipe & environment)	001A3900153	1
14	clip for sensor	001A5736055	1
15	Terminal block	001A4000158	1
16	Electric box	001A1301708	1
17	Top cover assy.	001A0100827	1
18	Slide plate(right)	001A0100733	1
19	Back grille	001A1303642	1
20	High pressure switch	001A3400138	1
21	segregator	001A20000175	1
22	coil of 4-way valve	001A2500121	1
23	4-way valve	001A2500117	1
24	muffle	001A2400128	1
25	Compressor	001A2000195	1
26	wiring harness	0010400044	1
27	2-way stop valve	001A2500115	1
28	3-way stop valve	001A2500116	1
29	Valve pedestal	001A1301762	1
30	Bottom cover assy.	001A0100735	1
31	Power line clip	001A5701062	1
32	Partition plate	001A0100734	1
33	Partition plate tray	001A17561212	1
34	handle	001A1436160	1
35	cover	001A1301763	1