

Service Manual

Heat Recovery Ventilation



VAM 150FAVE
VAM 250FAVE
VAM 350FAVE
VAM 500FAVE
VAM 650FAVE
VAM 800FAVE
VAM1000FAVE
VAM1500FAVE
VAM2000FAVE

Heat Recovery Ventilation



VAM 150FAVE
VAM 250FAVE
VAM 350FAVE
VAM 500FAVE
VAM 650FAVE
VAM 800FAVE
VAM1000FAVE
VAM1500FAVE
VAM2000FAVE

1. Introduction	V
1.1 Safety Cautions	V
Part 1 General Constructions	1
1. General Constructions	2
1.1 Explanation.....	2
Part 2 Product Specification	5
1. Product Specification	6
1.1 Specification	6
Part 3 Operation	9
1. Operation	10
1.1 Explanation for Systems.....	10
1.2 Operation HRV Units with The Remote Control exclusively for Air Conditioning Operation. (BRC301B61).....	11
1.3 Operating The HRV Unit Using The Remote Controller of The VRV-System Air Conditioner.....	13
1.4 Independent Operation of The HRV Unit Using The Centralized Controller (DCS302B61)	14
Part 4 Maintenance	15
1. Maintenance.....	16
1.1 Maintenance for The Air Filter	16
1.2 Maintenance for The Heat Exchange Element.....	18
Part 5 Control Functions	19
1. Control Functions	20
1.1 List of Control Functions.....	20
1.2 Explanation of Individual Functions.....	21
1.3 Layout of switches on Printed Circuit Board.....	27
Part 6 Circuit Operations	29
1. Circuit Operations	30
1.1 Circuit Configuration	30
1.2 Circuit Functions.....	31
Part 7 Troubleshooting	33
1. Troubleshooting	34
1.1 Error Code Indication.....	34
1.2 Overall Alarm.....	35
1.3 Overall Malfunction.....	36
1.4 Indoor Air Thermistor Error.....	37
1.5 Outdoor Air Thermistor Error.....	38
1.6 Damper System Error (Alarm).....	39
1.7 Damper System Error (Alarm).....	40
1.8 Dedicated LCD Remote Controller	41

- 1.9 Data Transmission Error
(Between LCD Remote Controller and Main Unit)..... 42
- 1.10 Data Transmission Error (LCD Remote Controller)..... 43
- 1.11 Data Transmission Error (Between LCD Master Remote Controller
and Slave Remote Controller) 44
- 1.12 Field Setting Error..... 45
- 1.13 Overlapping Central Control Address..... 46
- 1.14 Main Unit PCB Assembly 47
- 1.15 Dedicated LCD Remote Controller 48
- 1.16 How to Check 49
- 1.17 Thermistor 50
- 1.18 Power Transformer..... 51
- 1.19 Damper Motor..... 52

Part 8 Supplementary Explanation.....53

- 1. Supplementary Explanation54
 - 1.1 Field Setting, Service Mode Operation..... 54

Part 9 Appendix.....65

- 1. Appendix66
 - 1.1 Wiring Diagram..... 66







Indexi

Drawings & Flow Chartsv

1. Introduction

1.1 Safety Cautions

Cautions and Warnings

- Be sure to read the following safety cautions before conducting repair work.
- The caution items are classified into “ **Warning**” and “ **Caution**”. The “ **Warning**” items are especially important since they can lead to death or serious injury if they are not followed closely. The “ **Caution**” items can also lead to serious accidents under some conditions if they are not followed. Therefore, be sure to observe all the safety caution items described below.
- About the pictograms
 -  This symbol indicates an item for which caution must be exercised.
The pictogram shows the item to which attention must be paid.
 -  This symbol indicates a prohibited action.
The prohibited item or action is shown inside or near the symbol.
 -  This symbol indicates an action that must be taken, or an instruction.
The instruction is shown inside or near the symbol.
- After the repair work is complete, be sure to conduct a test operation to ensure that the equipment operates normally, and explain the cautions for operating the product to the customer.

1.1.1 Cautions in Operation and Maintenance

! WARNING

! WARNING

Never inspect or service the unit by yourself.
Ask a qualified service person to perform this work.
(The qualified service person)

WARNING: Before obtaining access to terminal devices (**!**), all power supply circuit must be interrupted.

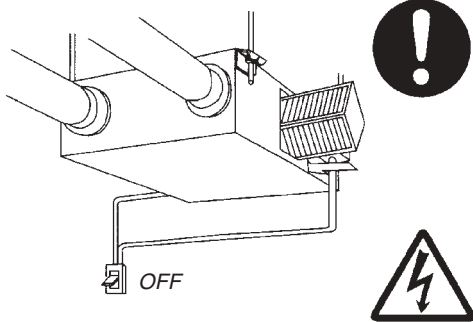

Electric shock may result. Before servicing the unit, always shut off power.



! WARNING

Always use the air filter.
If the air filter is not used, heat exchange elements will be clogged, possibly causing poor performance and subsequent failure.

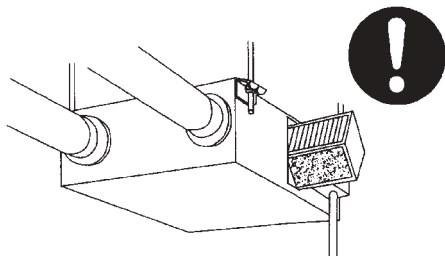

! WARNING

Do not change operations suddenly. It can result not only in malfunction but also failure of switches or relays in the body.

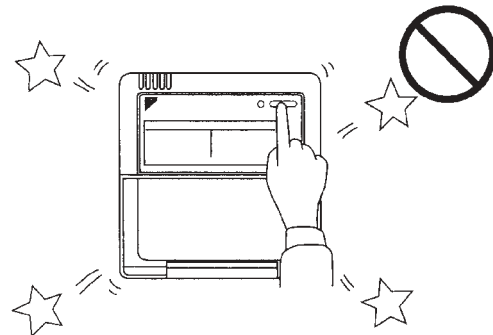

! WARNING

! WARNING Do not use a HRV or an air suction/discharge grille in the following places.

- **Place such as machinery plant and chemical plant where gas, which contains noxious gas or corrosive components of materials such as acid, alkali, organic solvent and paint, is generated. Place where combustible gas leakage is likely.**

Such gas can cause fire.

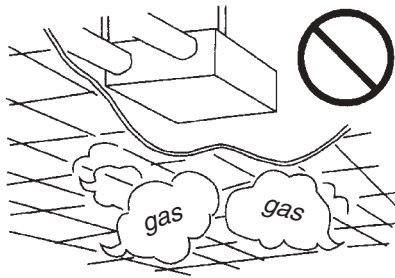

- **Place subjected to high temperature or direct flame.**

Avoid a place where the temperature near the HRV unit and the air suction/discharge air grille exceeds 50°C. If the unit is used at high temperature, deformed air filter and heat exchange element or burned motor result.

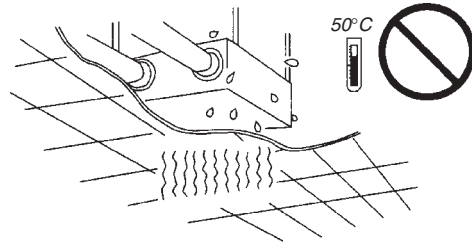

- **Place such as bathroom subjected to moisture.**

Electric leak or electric shock and other failure can be caused.

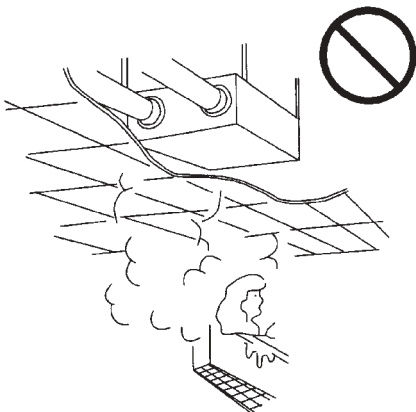

- **Place subjected to much carbon black.**



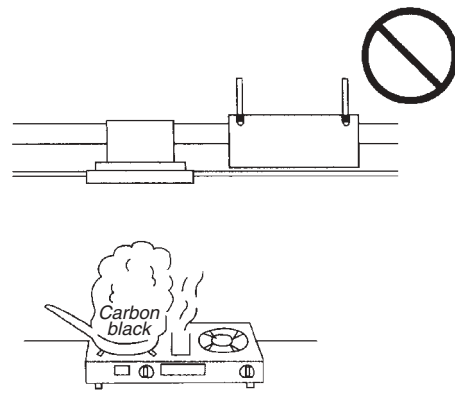

Carbon black attaches to air filter and heat exchange element, marking them unable to use.



1.1.2 Using Icons

Icons are used to attract the attention of the reader to specific information. The meaning of each icon is described in the table below:

1.1.3 Using Icons List

Icon	Type of Information	Description
 Note:	Note	A “note” provides information that is not indispensable, but may nevertheless be valuable to the reader, such as tips and tricks.
 Caution	Caution	A “caution” is used when there is danger that the reader, through incorrect manipulation, may damage equipment, lose data, get an unexpected result or has to restart (part of) a procedure.
 Warning	Warning	A “warning” is used when there is danger of personal injury.
	Reference	A “reference” guides the reader to other places in this binder or in this manual, where he/she will find additional information on a specific topic.

Part 1

General Constructions

1. General Constructions	2
1.1 Explanation.....	2

1. General Constructions

1.1 Explanation

VAM150FAVE
 VAM250FAVE
 VAM350FAVE
 VAM500FAVE
 VAM650FAVE
 VAM800FAVE
 VAM1000FAVE

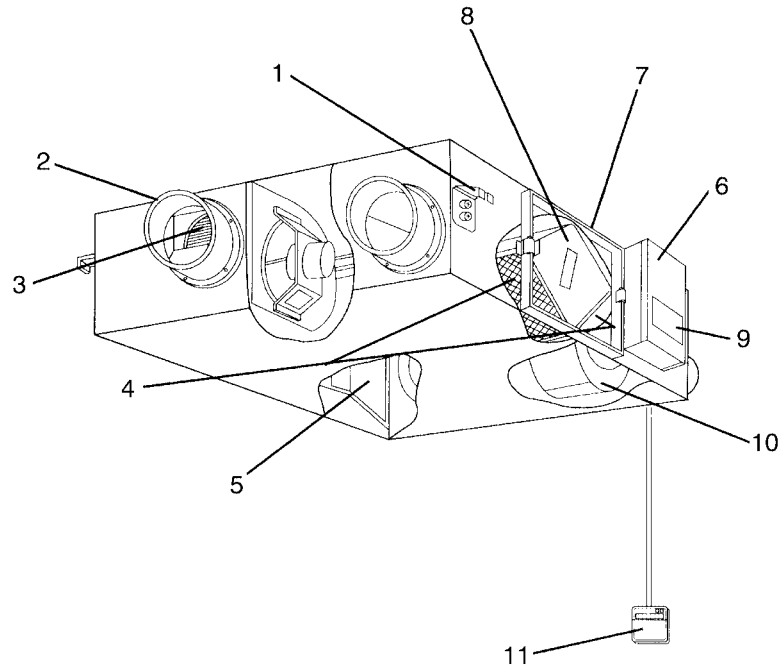

(HL001)

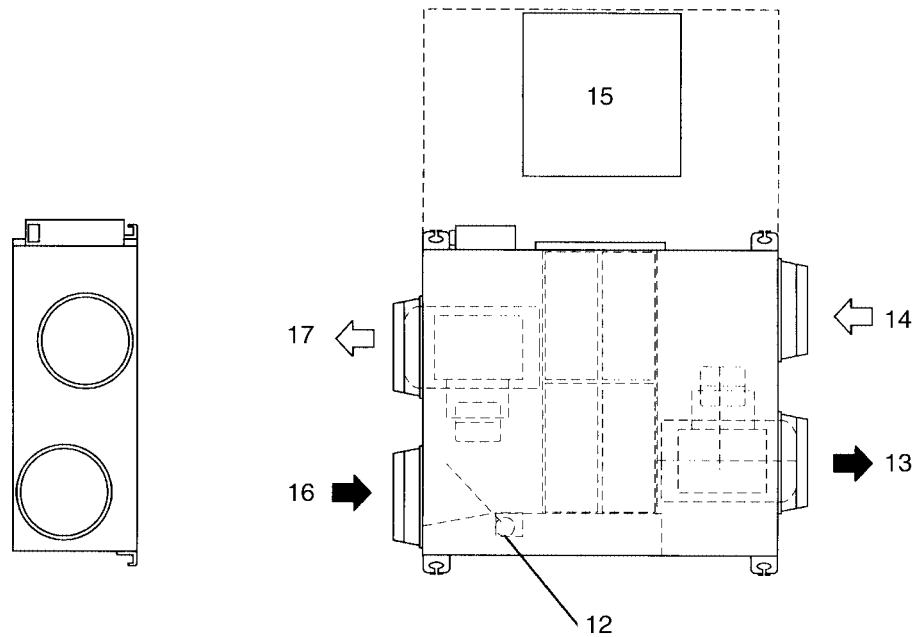

(HL002)

1	Ceiling Hock	2	Duct Connection Flange
3	Exhaust Fan	4	Air Filter (Long Life Filter)
5	Damper	6	Switch Box
7	Maintenance Cover	8	Heat Exchange Elements
9	Name Plate	10	Air Supply Fan
11	Remote Controller (Option Parts)	12	Damper Motor
13	EA (Exhaust Air) [Exhaust Air to Outdoor]	14	OA (Outdoor Air) [Fresh Air from Outdoor]
15	Maintenance Space for The Air Filters, Heat Exchange Elements and Switch Box	16	RA (Return Air) [Exhaust Air from Room]
17	SA (Supply Air) [Feed Air to Room]		

VAM1500FAVE
VAM2000FAVE

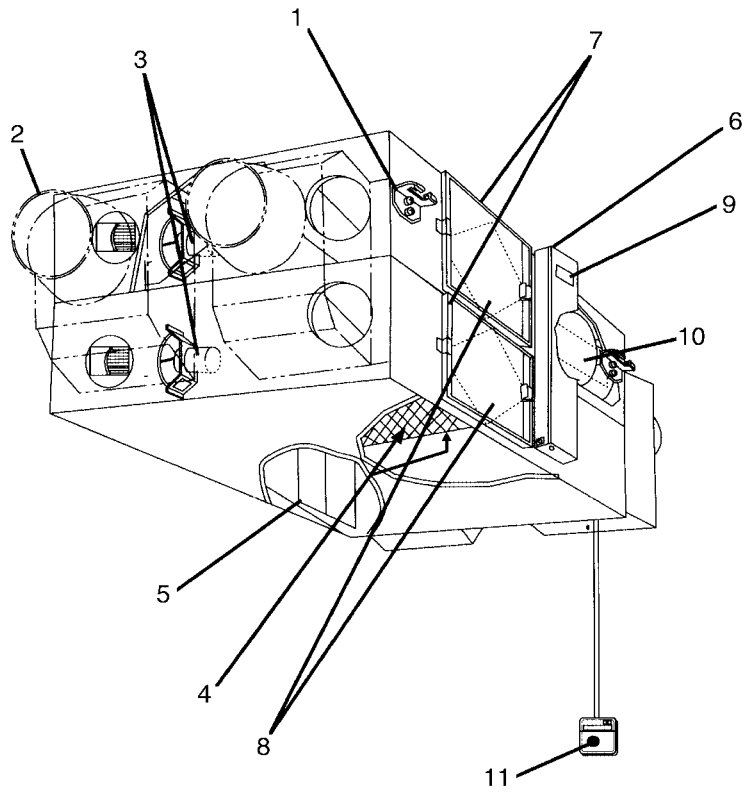

(HL016)

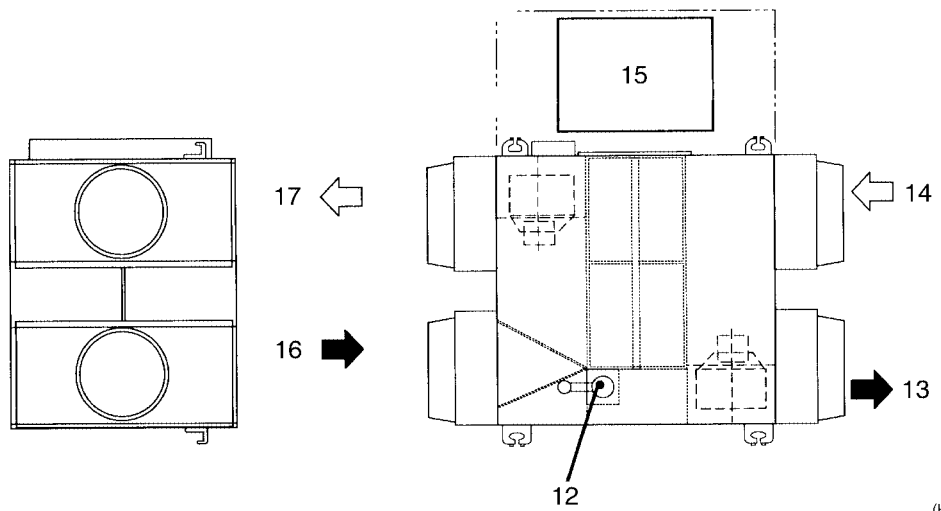

(HL017)

1	Ceiling Hock	2	Duct Connection Flange
3	Exhaust Fan	4	Air Filter (Long Life Filter)
5	Damper	6	Switch Box
7	Maintenance Cover	8	Heat Exchange Elements
9	Name Plate	10	Air Supply Fan
11	Remote Controller (Option Parts)	12	Damper Motor
13	EA (Exhaust Air) [Exhaust Air to Outdoor]	14	OA (Outdoor Air) [Fresh Air from Outdoor]
15	Maintenance Space for The Air Filters, Heat Exchange Elements and Switch Box	16	RA (Return Air) [Exhaust Air from Room]
17	SA (Supply Air) [Feed Air to Room]		

Part 2

Product Specification

1. Product Specification	6
1.1 Specification	6

1. Product Specification

1.1 Specification

(50 / 60Hz)

Model Name				VAM150FAVE	VAM250FAVE	VAM350FAVE	
Power Supply				Single Phase 220 – 240 V / 220 V, 50 / 60 Hz			
Temperature Exchanging Efficiency	Ultra-High	%		74 / 74	72 / 72	75 / 75	
			High	%	74 / 74	72 / 72	75 / 75
			Low	%	79 / 80	77 / 77	80 / 81
Enthalpy Exchange Efficiency	Cooling	Ultra-High	%	58 / 58	58 / 58	61 / 61	
		High	%	58 / 58	58 / 58	61 / 61	
		Low	%	64 / 66	62 / 63	67 / 68	
	Heating	Ultra-High	%	64 / 64	64 / 64	65 / 65	
		High	%	64 / 64	64 / 64	65 / 65	
		Low	%	69 / 71	68 / 69	70 / 71	
Casing				Galvanized Steel Plate			
Insulating Material				Self-extinguishable Urethane Foam			
Dimensions		H × W × D	mm	269 × 760 × 509	269 × 760 × 509	285 × 812 × 800	
Heat Exchanging System				Air to Air Cross Flow Total Heat (Sensible Heat + Latent Heat) Exchange			
Heat Exchanging Element				Specially Processed Nonflammable Paper			
Air Filter				Multidirectional Fibrous Fleeces			
Fan	Type			Sirocco Fan			
	Fan Speed	Ultra-High	m ³ / h	150 / 150	250 / 250	350 / 350	
		High	m ³ / h	150 / 150	250 / 250	350 / 350	
		Low	m ³ / h	110 / 110	155 / 145	230 / 210	
	External Static Pressure	Ultra-High	Pa	69 / 98	64 / 98	98 / 142	
		High	Pa	39 / 54	39 / 54	70 / 85	
		Low	Pa	20 / 24	20 / 20	25 / 15	
Fan Motor				Type Open Type Capacitor Permanent Split-phase Induction Motor, 4 Poles × 2			
Motor Output				kW 0.030 × 2 0.030 × 2 0.090 × 2			
Operating Sound	Heat Exchange Mode	Ultra-High	dBA	27 – 28.5 / 28.52	28 – 29 / 29.5	32 – 34 / 34.5	
		High	dBA	26 – 27.5 / 26.5	26 – 27 / 26	31.5 – 33 / 32	
		Low	dBA	20.5 – 21.5 / 19	21 – 22 / 19.5	23.5 – 26 / 22	
	Bypass Mode	Ultra-High	dBA	27 – 28.5 / 28	28 – 29 / 29	32 – 34 / 34.5	
		High	dBA	26.5 – 27.5 / 27	27 – 28 / 27	31 – 32.5 / 33	
		Low	dBA	20.5 – 21.5 / 20	21 – 22 / 20.5	24.5 – 26.5 / 22	
Operation Range (Ambient)				–15°C to 50°CDB (80% RH or Less)			
Connection Duct Diameter			mm	φ 100	φ 150	φ 150	
Weight			kg	24	24	33	
Drawing Number				4D020371A	4D020372A	4D020373A	

Test conditions are as follows

Condition	Indoor		Outdoor	
	°CDB	R-H (%)	°CDB	R-H (%)
Cooling condition	27	50	35	60
Heating condition	20	40	7	70

Notes:

1. Operation sound is measured at 1.5 m below the center the body.
2. Fan speed can be changed over to Low mode or High mode.
3. Operating sound is measured in an anechoic chamber.
Operating sound level generally become greater than this value depending on the operating conditions, reflected sound, and peripheral noise.
4. The sound level at the air discharge port is about 8 dB higher than the unit's operating sound.

(50 / 60Hz)

Model Name			VAM500FAVE	VAM650FAVE	VAM800FAVE	
Power Supply			Single Phase 220 – 240 V / 220 V, 50 / 60 Hz			
Temperature Exchanging Efficiency	Ultra-High	%	74 / 74	74 / 74	74 / 74	
	High	%	74 / 74	74 / 74	74 / 74	
	Low	%	77 / 78.5	77 / 78	76 / 76	
Enthalpy Exchange Efficiency	Cooling	Ultra-High	58 / 58	58 / 58	60 / 60	
		High	58 / 58	58 / 58	60 / 60	
		Low	63 / 65.5	63 / 65	62 / 63	
	Heating	Ultra-High	62 / 62	63 / 63	65 / 65	
		High	62 / 62	63 / 63	65 / 65	
		Low	67 / 68.5	66 / 68	67 / 68	
Casing			Galvanized Steel Plate			
Insulating Material			Self-extinguishable Urethane Foam			
Dimensions		H × W × D mm	285 × 812 × 800	348 × 988 × 852	348 × 988 × 852	
Heat Exchanging System			Air to Air Cross Flow Total Heat (Sensible Heat + Latent Heat) Exchange			
Heat Exchanging Element			Specially Processed Nonflammable Paper			
Air Filter			Multidirectional Fibrous Fleeces			
Fan	Type		Sirocco Fan			
	Fan Speed	Ultra-High	m ³ / h	500 / 500	650 / 650	800 / 800
		High	m ³ / h	500 / 500	650 / 650	800 / 800
		Low	m ³ / h	350 / 300	500 / 440	670 / 660
	External Static Pressure	Ultra-High	Pa	98 / 147	93 / 162	137 / 225
		High	Pa	54 / 54	39 / 69	98 / 118
Low		Pa	25 / 20	25 / 34	49 / 69	
Fan Motor		Type	Open Type Capacitor Permanent Split-phase Induction Motor, 4 Poles × 2			
Motor Output		kW	0.090 × 2	0.140 × 2	0.230 × 2	
Operating Sound	Heat Exchange Mode	Ultra-High	dBA	33 – 34.5 / 34	34.5 – 35.5 / 36	36 – 37 / 37
		High	dBA	31.5 – 33 / 31	33 – 34 / 33	34.5 – 36 / 35
		Low	dBA	24.5 – 26.5 / 24	27 – 28 / 27	31 – 32 / 30
	Bypass Mode	Ultra-High	dBA	33.5 – 34.5 / 35	34.5 – 35.5 / 35.5	36 – 37 / 37
		High	dBA	32.5 – 33.5 / 33	34 – 35 / 34	34.5 – 36 / 35
		Low	dBA	25.5 – 27.5 / 24	27 – 28.5 / 27	31 – 33 / 31
Operation Range (Ambient)			–15°C to 50°CDB (80% RH or Less)			
Connection Duct Diameter		mm	φ 200	φ 200	φ 250	
Weight		kg	33	48	48	
Drawing Number			4D020374A	4D020375A	4D020376A	

Test conditions are as follows

Condition	Indoor		Outdoor	
	°CDB	R-H (%)	°CDB	R-H (%)
Cooling condition	27	50	35	60
Heating condition	20	40	7	70

Notes:

1. Operation sound is measured at 1.5 m below the center the body.
2. Fan speed can be changed over to Low mode or High mode.
3. Operating sound is measured in an anechoic chamber.
Operating sound level generally become greater than this value depending on the operating conditions, reflected sound, and peripheral noise.
4. The sound level at the air discharge port is about 8 dB higher than the unit's operating sound.

(50 / 60Hz)

Model Name			VAM1000FAVE	VAM1500FAVE	VAM2000FAVE	
Power Supply			Single Phase 220 – 240 V / 220 V, 50 / 60 Hz			
Temperature Exchanging Efficiency	Ultra-High	%	75 / 75	75 / 75	75 / 75	
	High	%	75 / 75	75 / 75	75 / 75	
	Low	%	76.5 / 78	78 / 78	78 / 78	
Enthalpy Exchange Efficiency	Cooling	Ultra-High	61 / 61	61 / 61	61 / 61	
		High	61 / 61	61 / 61	61 / 61	
		Low	63 / 66	64 / 64	66 / 66	
	Heating	Ultra-High	66 / 66	66 / 66	66 / 66	
		High	66 / 66	66 / 66	66 / 66	
		Low	68 / 71	68 / 68	70 / 70	
Casing			Galvanized Steel Plate			
Insulating Material			Self-extinguishable Urethane Foam			
Dimensions		H × W × D mm	348 × 988 × 1140	710 × 1498 × 852	710 × 1498 × 1140	
Heat Exchanging System			Air to Air Cross Flow Total Heat (Sensible Heat + Latent Heat) Exchange			
Heat Exchanging Element			Specially Processed Nonflammable Paper			
Air Filter			Multidirectional Fibrous Fleeces			
Fan	Type		Sirocco Fan			
	Fan Speed	Ultra-High	m ³ / h	1000 / 1000	1500 / 1500	2000 / 2000
		High	m ³ / h	1000 / 1000	1500 / 1500	2000 / 2000
		Low	m ³ / h	870 / 800	1200 / 1200	1400 / 1400
	External Static Pressure	Ultra-High	Pa	157 / 196	137 / 206	137 / 196
		High	Pa	98 / 108	98 / 118	78 / 88
Low		Pa	78 / 69	49 / 69	59 / 69	
Fan Motor		Type	Open Type Capacitor Permanent Split-phase Induction Motor, 4 Poles × 2			
Motor Output		kW	0.230 × 2	0.230 × 4	0.230 × 4	
Operating Sound	Heat Exchange Mode	Ultra-High	dBA	36 – 37 / 37	39.5 – 41.5 / 40.5	40 – 42.5 / 41
		High	dBA	35 – 36 / 35	38 – 39 / 38	38 – 41 / 38
		Low	dBA	31 – 32 / 30	34 – 36 / 33	35 – 37 / 35
	Bypass Mode	Ultra-High	dBA	36 – 37 / 37	40.5 – 41.5 / 40.5	40 – 42.5 / 41
		High	dBA	35.5 – 36 / 35	38 – 39 / 38	38 – 41 / 38
		Low	dBA	31 – 32 / 31	33.5 – 36 / 33	35 – 37 / 35
Operation Range (Ambient)			–15°C to 50°CDB (80% RH or Less)			
Connection Duct Diameter		mm	φ 250	φ 350	φ 350	
Weight		kg	61	132	158	
Drawing Number			4D020377A	4D020526A	4D020527A	

Test conditions are as follows

Condition	Indoor unit		Outdoor unit	
	°CDB	R-H (%)	°CDB	R-H (%)
Cooling condition	27	50	35	60
Heating condition	20	40	7	70

Notes:

1. Operation sound is measured at 1.5 m below the center the body.
2. Fan speed can be changed over to Low mode or High mode.
3. Operating sound is measured in an anechoic chamber.
Operating sound level generally become greater than this value depending on the operating conditions, reflected sound, and peripheral noise.
4. The sound level at the air discharge port is about 8 dB higher than the unit's operating sound.

Part 3 Operation

1. Operation	10
1.1 Explanation for Systems.....	10
1.2 Operation HRV Units with The Remote Control exclusively for Air Conditioning Operation. (BRC301B61).....	11
1.3 Operating The HRV Unit Using The Remote Controller of The VRV-System Air Conditioner.....	13
1.4 Independent Operation of The HRV Unit Using The Centralized Controller (DCS302B61)	14

1. Operation

1.1 Explanation for Systems

This product is operated differently depending on the system configuration.

For the operation of the remote controller for indoor unit and centralized controller, refer to the instruction manual provided with each unit.

■ Operation for Each System

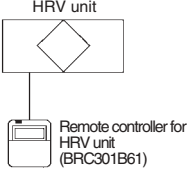
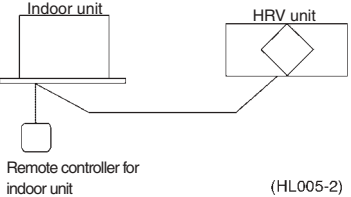
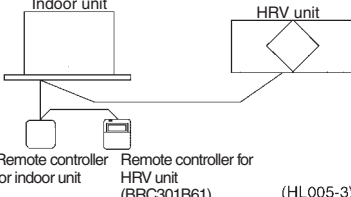
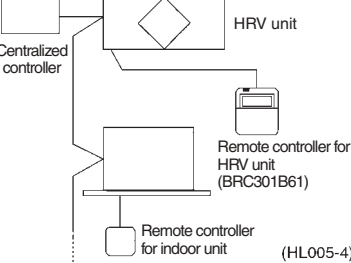
System Example	Operation Method
<p>Independent System</p>  <p>(HL005-1)</p>	<p>The remote controller turns on and off the air conditioner and HRV unit.</p>
<p>Combined Operation System with VRV Systems and Skyair Series</p>  <p>(HL005-2)</p>	<p>The remote controller for VRV turns on and off the air conditioner and HRV unit. If only the HRV unit is used without operating the air conditioner, set the unit in the "VENTILATION" mode.</p>
 <p>(HL005-3)</p>	<p>The ON/OFF and timer operation can not be performed using the HRV remote controllers. (The indication of centralized control " " appears on the display.) Other operations can be performed using the HRV remote controllers. Starting and stopping operations of the indoor unit and the HRV unit can be performed using the indoor remote controllers.</p>
<p>Centralized System</p>  <p>(HL005-4)</p>	<p>When the HRV remote controllers is not connected, the Centralized controller controls the operation of the HRV unit.</p> <p>When the HRV remote controllers is connected, operation can be started and stopped using the Centralized controller or the indoor and the HRV remote controllers. During the indication of centralized control " " appears on the display, the ON/OFF and timer operation may not be possible with the HRV remote controllers. Other operations can be performed using the HRV remote controllers.</p>

1.2 Operation HRV Units with The Remote Control exclusively for Air Conditioning Operation. (BRC301B61)

For non-independent systems, starting/stopping operation and timer operation may not be possible. Use the air conditioner remote control or the Centralized controller in such cases.

Remote Controller for HRV BRC301B61

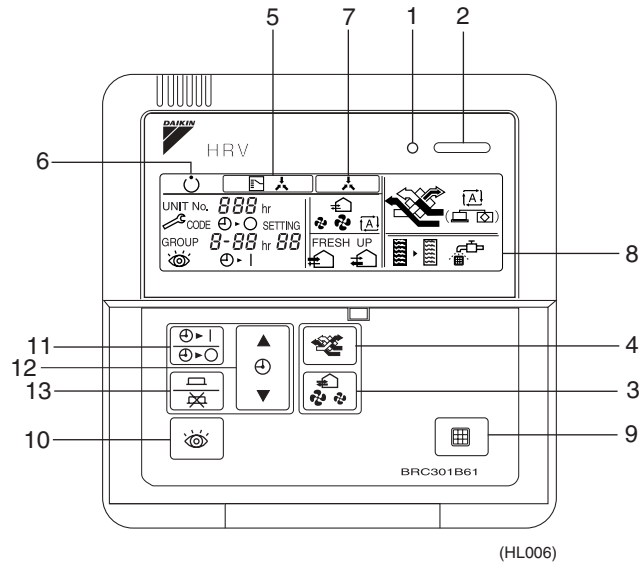

(HL006)

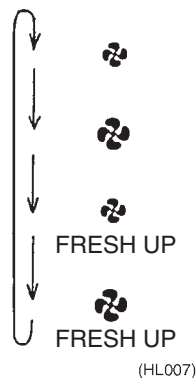

(HL007)

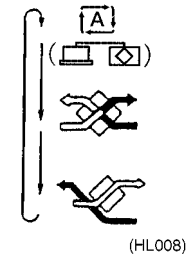

(HL008)

Operation for INDIVIDUAL SYSTEM

1. Operation lamp
This pilot lamp (red) light up while the unit is in Operation.
2. Operation/Stop button
When pushed once, the unit starts operating.
When pushed twice, the unit stops.
3. Air flow rate changeover button
Air flow rate can be changed over to “” [Low] mode or “” [High] mode, “ FRESH UP” [Low FRESH UP] mode, “ FRESH UP” [High FRESH UP] mode.

For “Freshup” operation

When this indication does not show: The volume of outdoor air supplied into the room and that of the room air exhausted outdoors is equivalent.

For “Freshup” operation,

- If it is set to “Fresh up air supply”: The volume of outdoor air supplied into the room is larger than that of room air exhausted outdoors.
(This operation prevents the odor and moisture from kitchens and toilets from flowing into the rooms.)
- If it is set to “Fresh up air exhaust”: The volume of room air exhausted outdoors is larger than that of outdoor air supplied into the room.
(This operation prevents the hospital odor and floating bacteria from flowing out to the corridors.)

4. Ventilation mode changeover: button

"" (Automatic) mode The temperature sensor of the unit automatically changes the ventilation of the unit in [Bypass] mode and [Heat Exchange] mode.

"" (Heat Exchange) mode In this mode, the air passes through the heat exchange element to effect [Total Heat Exchanging] ventilation.

"" (Bypass) mode In this mode, the air does not pass through the heat exchange element but bypasses it to effect [Bypass] ventilation.

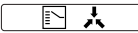
5. Indication of operation control method: 

When the operation of HRVs are linked with the air conditioners, this indication may be shown. While the indication is shown, the ON/OFF of HRVs cannot be operated by the HRV remote controller.

6. Indication of operation standby: 

It indicates the precooling/preheating operation. This unit is at stop and will start operation after the precooling/preheating operation is over.

Precooling/preheating operation means the operation of HRVs is delayed during the startup operation of linked air conditioners such as before the office hours. During this period the cooling or heating load is reduced to bring the room temperature to the set temperature in a short time.

7. Indication of centralized control: 

When a remote controller for air conditioners or devices for centralized control are connected to the HRVs, this indication may show.

During this indication appears on the display, the ON/OFF and timer operation may not be possible with the HRV remote controllers.

8. Indication of air filter cleaning



When the indication "" appears on the display, clean the filter.

9. Filter signal reset button

10. Inspection button

This button is to be used only for service. It is not to be used normally.

HOW TO OPERATE WITH TIMER

11. Push the button "" and select either one of "" or "".

Each time the button is pushed, the indication changes as shown below.

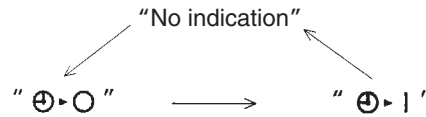

(HL009)



12. Push the button "" and set the time.

Each time when "" is pushed, the time advances one hour.

Each time when "" is pushed, the time goes back one hour.

13. Push the button "".

Then, the reservation is finished.

Either "" or "" changes from flashing to lighting.

After the reservation is finished, the remaining time is indicated in the display.



For cancelling the timer operation, push the button "" once again.

The indication disappears.



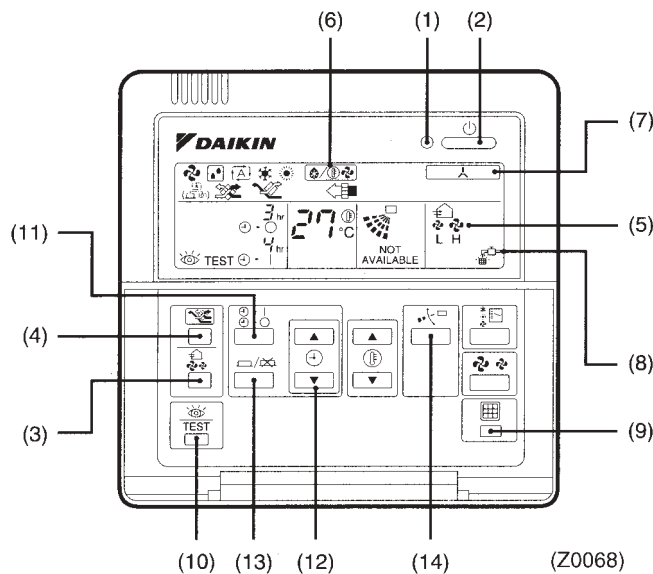

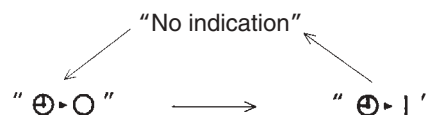

1.3 Operating The HRV Unit Using The Remote Controller of The VRV-System Air Conditioner

Remote Controller
for VRV
BRC1C51-61



1. Operation lamp
2. Operation/stop button
3. Air flow rate changeover button
4. Ventilation mode changeover button
5. Indication of air flow rate
6. Indication of operation control method
7. Indication of centralized control
8. indication of air filter cleaning
9. Filter signal reset button
10. Inspection button
11. Push the button “” and select either one of “” or “”.
Each time the button is pushed, the indication changes as shown below.



12. Push the button “” and set the time.
Each time when “” is pushed, the time advances one hour.
Each time when “” is pushed, the time goes back one hour.
13. Push the button “”
Then, the reservation is finished.
Either “” or “” changes from flashing to lighting.
After the reservation is finished, the remaining time is indicated in the display.
For cancelling the timer operation, push the button “” once again.
The indication disappears.
14. If you press these buttons when using independent operation of the HRV unit, the message “Not Available” will appear on the display for a few seconds.
 - When the VRV-system air conditioner is connected with the HRV unit with a direct duct, the remote controller of the air conditioner cannot be used to select the VENTILATION mode. To use the HRV unit without operating the air conditioner, set the air conditioner in the FAN VENTILATION mode and select the low fan speed.

Remote Controller for VRV BRC1A51

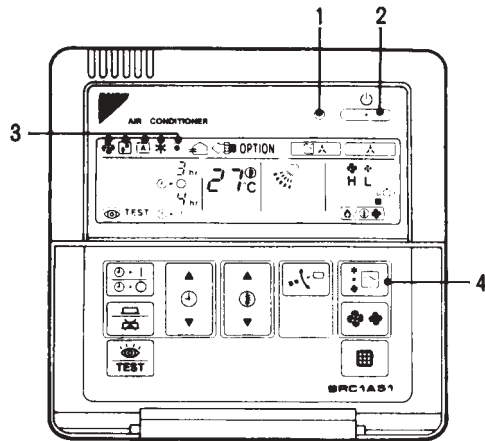

(HL010)

1. Operation lamp
2. Operation/stop button
3. Operation mode display
4. Operation mode selector

■ When the VRV-system air conditioner is connected with the HRV unit with a direct duct, the remote controller of the air conditioner cannot be used to select the VENTILATION mode. To use the HRV unit without operating the air conditioner, set the air conditioner in the FAN VENTILATION mode and select the low fan speed.

■ Every time the operation mode selector is pressed, the operation mode display changes as shown below.

(example)

When air conditioner and HRV unit are not connected by duct	When air conditioner and HRV unit are connected by duct
<p>(HL011)</p>	<p>(HL012)</p>

■ When the "FILTER" indication appears on the display, clean the filter of the HRV unit.

1.4 Independent Operation of The HRV Unit Using The Centralized Controller (DCS302B61)

- After selecting the zone where the only the HRV unit operation is desired, press the operation mode selector and select " " VENTILATION. The HRV unit can then be operated independently from the air conditioner.
- When the "FILTER" indication appears on the display, clean the filter of the HRV unit.

Part 4

Maintenance

1. Maintenance.....	16
1.1 Maintenance for The Air Filter	16
1.2 Maintenance for The Heat Exchange Element.....	18

1. Maintenance

1.1 Maintenance for The Air Filter



Caution

During operation, never check or clean the HRV. It may cause electrical shock and it is very dangerous to touch the rotating part. Be sure to turn off the OPERATION switch and disconnect the power.

■ **CLEANING FREQUENCY**

AT LEAST ONCE EVERY TWO YEARS (FOR GENERAL OFFICE USE)
(CLEAN THE ELEMENT MORE FREQUENTLY IF NECESSARY.)

1. Go into ceiling through the inspection hole, remove the hanging metals of maintenance cover and take it off.

VAM150~1000FAVE

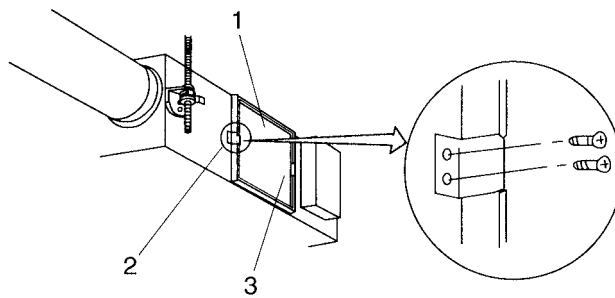

(HL003)

1	Maintenance Cover	2	Binding Metal
3	Hanging Metal		

VAM1500~2000FAVE

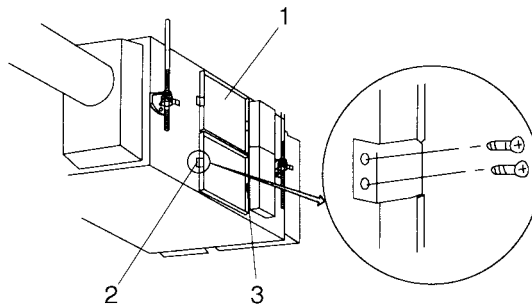

(HL004)

1	Maintenance Cover	2	Binding Metal
3	Hanging Metal		

2. Take out the heat exchange elements from the unit body.

VAM150~1000FAVE

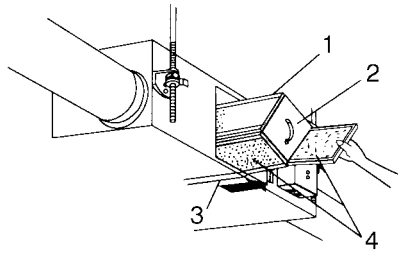

(HL013)

1	Heat Exchange Element (X2)	2	Handle
3	Rail	4	Filter × 2

VAM1500~2000FAVE

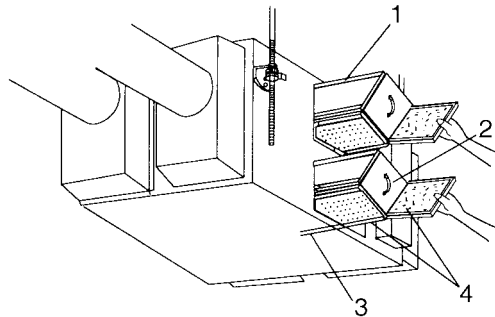

(HL014)

1	Heat Exchange Element (X4)	2	Handle
3	Rail	4	Filter × 4

3. To clean the air filter, lightly pat it with hand or remove dust with a vacuum cleaner. If excessively dirty, wash it in water.

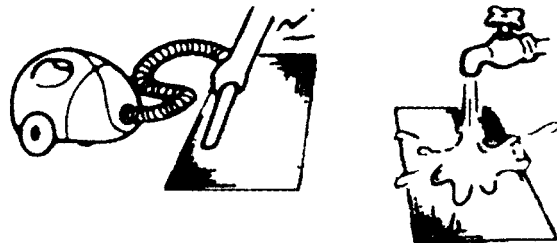

(HL015)

4. If the air filter is washed, remove water completely and allow to dry Air filter for 20 to 30 minutes in the shade. When dried completely, install the air filter back in place.

5. Install the maintenance cover securely in place.

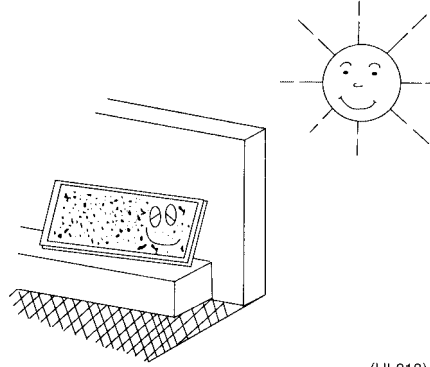

(HL018)

**Caution**

1. Do not wash the air filter in hot water.
2. Do not dry the air filter over a fire.
3. Do not expose the air filter to direct sunlight.
4. Do not use organic solvent such as gasoline and thinner on the air filter.
5. Be sure to install the air filter after servicing.
(Missing air filter causes clogged heat exchange element.)
The air filter is an optional item and the replacement is available.

1.2 Maintenance for The Heat Exchange Element

■ CLEANING FREQUENCY

AT LEAST ONCE EVERY TWO YEARS (FOR GENERAL OFFICE USE)
(CLEAN THE ELEMENT MORE FREQUENTLY IF NECESSARY.)

1. Use a vacuum cleaner to remove dust and foreign objects on the surface of the heat exchange element.
 - Use the vacuum cleaner equipped with a brush on the tip of the suction nozzle.
 - Lightly contact the brush on the surface of the heat exchanging element when cleaning. (Do not crush the heat exchange element while cleaning.)
2. Install the air filter securely in place.
3. Put the heat exchange element on the rail and insert it securely in place.
4. Install the maintenance cover securely in place.

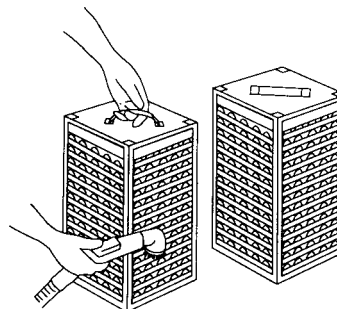

(HL060)

**Caution**

Never wash the heat exchanger element with water.

Part 5

Control Functions

1. Control Functions	20
1.1 List of Control Functions.....	20
1.2 Explanation of Individual Functions.....	21
1.3 Layout of switches on Printed Circuit Board.....	27

1. Control Functions

1.1 List of Control Functions

Classification	Function name	Outline of function
1. Basic functions (functions related to basic performance)	1.1 Ventilation operation control function	Controls supply air fan motor, exhaust air fan motor and damper motor.
	1.2 Abnormality control function	Detects abnormalities in thermistor, damper motor and data transmission to prevent errors.
2. Additional functions	2.1 Ventilation mode changeover function	Operates equipment in selected ventilation mode (total heat exchange, normal, automatic).
	2.2 Automatic ventilation operation function	Selects the most suitable ventilation mode by controlling damper motor according to temperature controller mode, temperature setting and thermistor data.
	2.3 Ventilation capacity changeover function	Operates equipment at set airflow rate.
	2.4 Humidifier operation control function	Controls humidifier output based on temperature controller judgment. Note 1
	2.5 Pre-cool/pre-heat function	Prevents equipment operation for a preset time (set time) after air conditioner is turned on.
	2.6 Freshup function	Sets motor tap so that supply air fan airflow rate is larger than exhaust air fan airflow rate.
	2.7 Filter sign function	Stores cumulative operation hour data and turns on air filter cleaning indicator.
3. System control functions	3.1 Remote controller function	Operates equipment according to instructions from remote controller.
	3.2 Group function	Operates two or more units based on instructions from single remote controller.
	3.3 Air conditioner link function	Follows air conditioner ON/OFF instructions.
	3.4 Power ON operation function	Operates equipment when power is turned on.
	3.5 External link operation function	Turns equipment on and off according to external link terminal signal (no-voltage contact a).
	3.6 Centralized control function	Allows remote control operation by centralized control equipment.
	3.7 Timer function	Turns equipment on and off at set time.
4. Other support functions	4.1 Troubleshooting function	Displays error codes to indicate locations of error.
	4.2 Field setting function	Allows initial setting from LCD remote controller.



Note:

Note 1

Requires optional humidifier and optional printed circuit board (KRP50-2 : Wiring adapter for remote contact).

1.2 Explanation of Individual Functions

1.2.1 Ventilation Operation Control

Controls ventilation fan motors (supply and exhaust air fans) and damper motor.

1) Normal operation

Operation chart

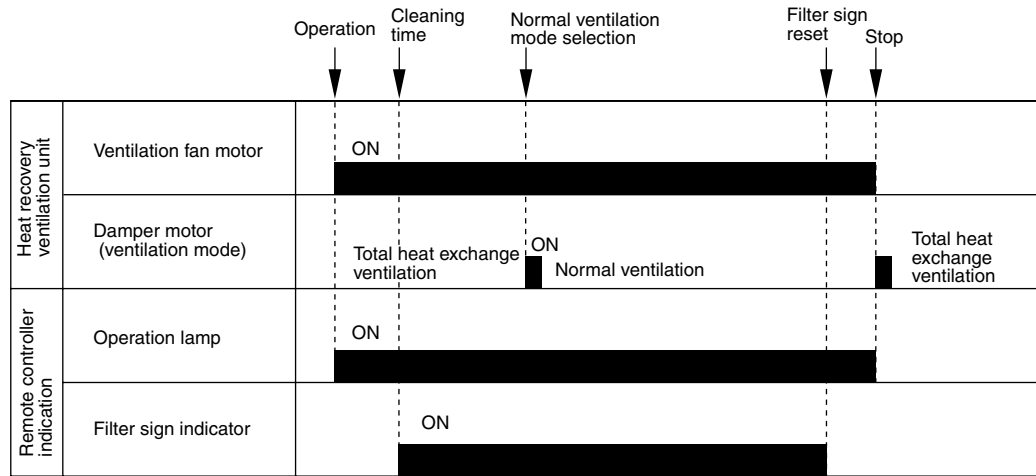

(HL020)

2) Direct duct connection with air conditioner

Operation chart

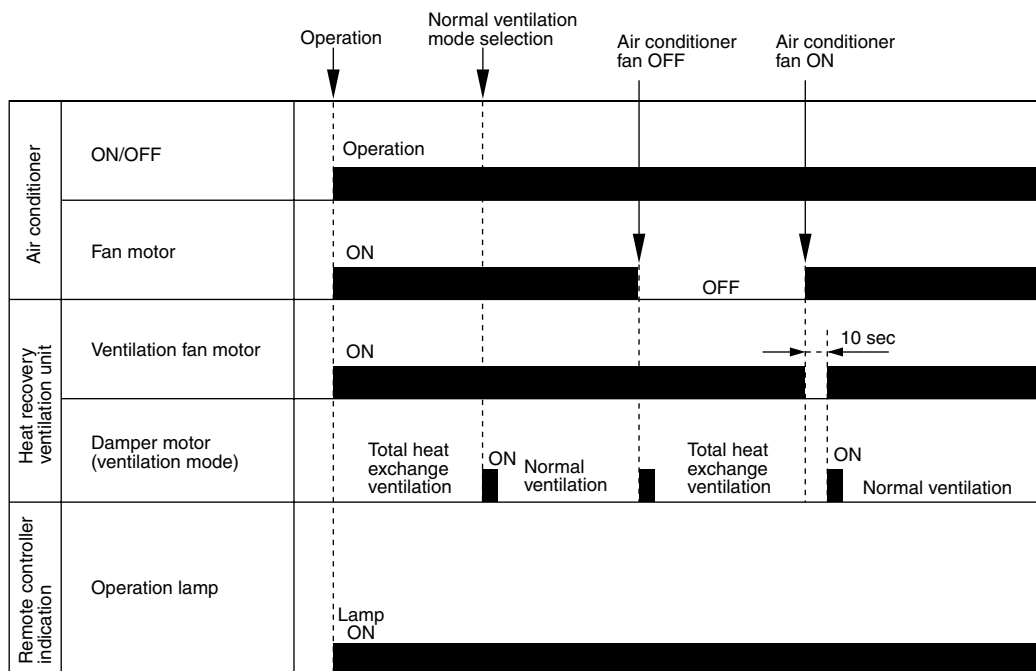

(HL021)



Note: Direct duct connection setting can be made in VRV system or using field setting mode of HRV LCD remote controller.

1.2.2 Pre-cool/Pre-heat

Pre-cool/pre-heat operations require the following conditions.

1. System
Pre-heat operation is possible only in air conditioner linked system (1 group, 2-group link). Check the system first.
2. Heat recovery ventilation setting
Set Preheat ON/OFF to ON.
Pre-cool/pre-heat On/OFF setting can be made in air conditioner or using field setting mode of LCD remote controller of heat recovery ventilation unit. (Pre-cool time can be set between 30 and 60 min, and pre-heat time can be set between 30 and 150 min.)
3. Others
 - a) Heat recovery ventilation unit must be in non-operating condition for two consecutive hours or more prior to pre-cool/pre-heat operation.
 - b) Temperature control mode of the air conditioner must be set to Cool, Heat or Dry.

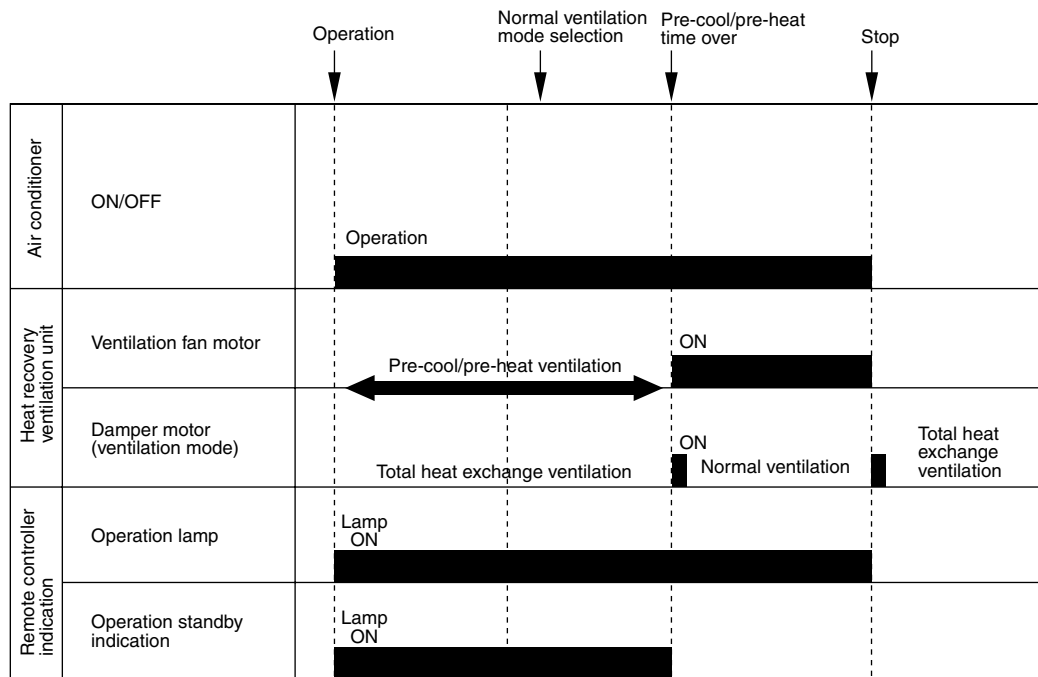

(HL022)

i Note: Operation standby indication is displayed only on LCD remote controller of heat recovery ventilation unit.

1.2.3 Cold Area Mode

Stops or lowers ventilation airflow during defrosting operation and compressor non-operating condition when equipment in heating mode, thus reducing heating load and cold air draft.

Operation chart (in heating operation only)

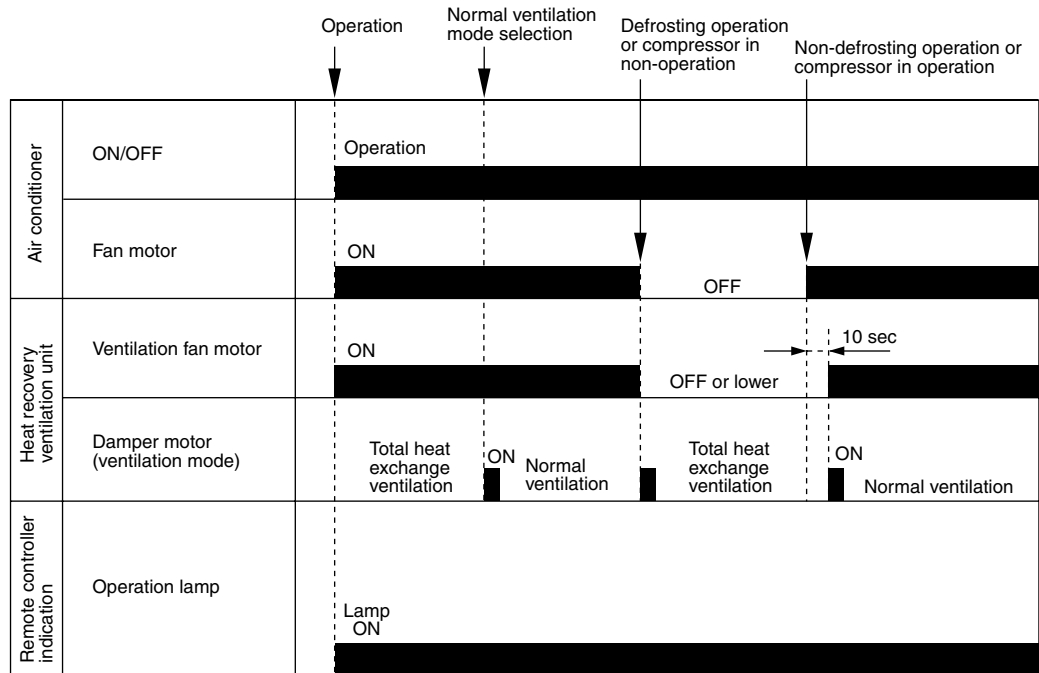

(HL023)



Note: Cold area mode can set using remote controller for air conditioner or field setting mode of LCD remoter controller of heat recovery ventilation unit.

1.2.4 Air Conditioner Link Operation

Link system enables simultaneous ON/OFF operation of heat recovery ventilation unit and air conditioner (VRV system, Skyair).

1) 1 group link control

- Allows simultaneous ON/OFF from remote controller for air conditioner.
- Allows independent operation of heat recovery ventilation unit from VRV-system remote controller during interim periods (not possible when direct duct connection is used).
- ON/OFF operation is not possible from LCD remote controller of heat recovery ventilation unit.

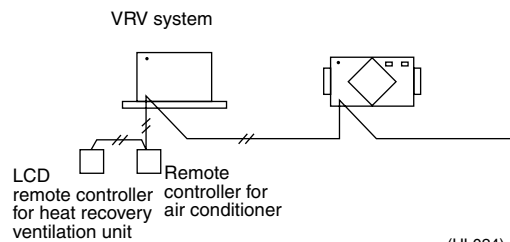

(HL024)

2) Link control of 2 or more groups (zone link)

- Heat recovery ventilation unit can be operated when one or more air conditioners are operating.
- Allows independent operation of heat recovery ventilation unit from VRV-system remote controller during interim periods (direct duct connection is not allowed in this system).
- ON/OFF operation is not possible from LCD remote controller of heat recovery ventilation unit.

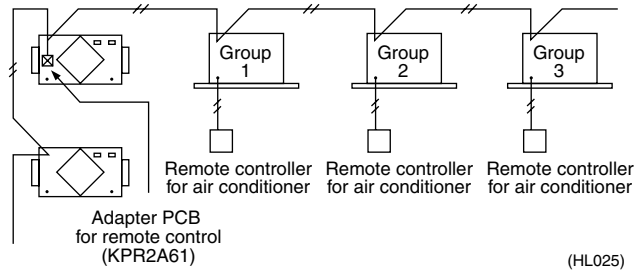

(HL025)







Note: With Super Wiring, units of different outdoor systems can be linked in operation.

1.2.5 Field Setting, Service Mode

1. Field setting
Used for initial setting of heat recovery ventilation unit.
2. Service mode
Used for confirmation of unit Nos. in the group and reallocation of unit Nos.

List of Field Setting and Service Mode

Details of setting	Mode	Setting mode	Setting switch No.	Setting position						Operation method		
				01	02	03	04	05	06			
Group No. setting for centralized controller (individual)	Field setting	00(30)									Refer to P55	
Filter cleaning time setting		17(27)	0	Approx. 2500 hr.	Approx. 1250 hr.	No counting	—	—	—		Refer to P54	
Pre-cool/pre-heat On/Off setting			2	Off	On	—	—	—	—			
Pre-cool/pre-heat time (min.) setting			3	30 min.	45 min.	60 min.	—	—	—			
Fan speed initial setting			4	Normal	Ultra-High	—	—	—	—			
Yes / No setting for direct duct Connection with VRV system			5	No duct (Air flow setting)	With duct (fan off)	—	—	—	—			
Setting for cold areas (Fan operation selection for heater thermostat OFF)				—	—	No duct		With duct				
Centralized / individual setting			7	Centralized	Individual	—	—	—	—			
Centralized zone interlock setting			8	No	Yes	Priority on Operation	—	—	—			
Pre-heat time extension setting			9	0	30 min.	60 min.	90 min.	—	—			
External signal setting JC / J2		18(28)	0	Last command	Priority on external input	—	—	—	—			
Setting for direct power-on			1	Off	On	—	—	—	—			
Auto restart setting			2	Off	On	—	—	—	—			
External damper operation	3		—	—	On	—	—	—				

Details of setting	Mode	Setting mode	Setting switch No.	Setting position						Operation method
				01	02	03	04	05	06	
Indication of ventilation mode / Not indication	Field setting	18(28)	4	Indication	No Indication	—	—	—	—	 Refer to P54
Fresh up air supply / exhaust setting			7	No Indication	No Indication	Indication	Indication	—	—	
				Supply	Exhaust	Supply	Exhaust	—	—	
External input terminal function selection (between J1 and JC)			8	Fresh up	Overall alarm	Overall malfunction	Forced off	Fan forced off	Air flow increase	
KRP50-2 output switching selection (between 1 and 3)		9	Humidify	Abnormal	Fan on / off	—	—	—		
Air flow setting		19(29)	0	Low	Low	Low	Low	High	High	
Ventilation mode setting			2	Automatic	Total heat exchange	Normal	—	—	—	
Fresh up operation			3	OFF	ON	—	—	—	—	
Electric heater setting	8		No delay	No delay	ON / OFF Delay	ON / OFF Delay	—	—	 Refer to E/D "INSTALLATION MANUAL"	
Error record display	Service	40							 Refer to operation manual for remote controller of air conditioner	
Forced ventilation fan On		43							 Refer to P56	
Unit No. allocation		45							 Refer to P57	

**Note:**

- All the setting can be made by the remote controller for VRV and HRV unit.
The setting of mode No. 19 (29) and 40 can be made only by the remote controller for VRV unit. The mode No. 30 is used for the individual setting such as the calculation of power bill, etc.
- The mode No. in () is used for making individual setting of each unit.
- Group number setting for centralized controller**
 - Mode no. 00: Group controller
 - Mode no. 30: Individual controller

* Regarding the setting procedure, refer to the section "Group number setting for centralized control" in the operating manual of either the on / off controller or the central controller.

**Caution**

- The setting positions are set at "01" at the factory.
The ventilation air flow, however, is set at "05" (medium) in the HRV unit. When lower or higher setting is desired, change the setting after installation.

1.2.6 External Damper Operation (FIELD SUPPLY)

Explanation of Functions

Intake of outdoor air can be prevented when HRV is switched OFF if this damper is incorporated in the system.

1. The total heat exchanger's main unit print board supplies power for external damper.

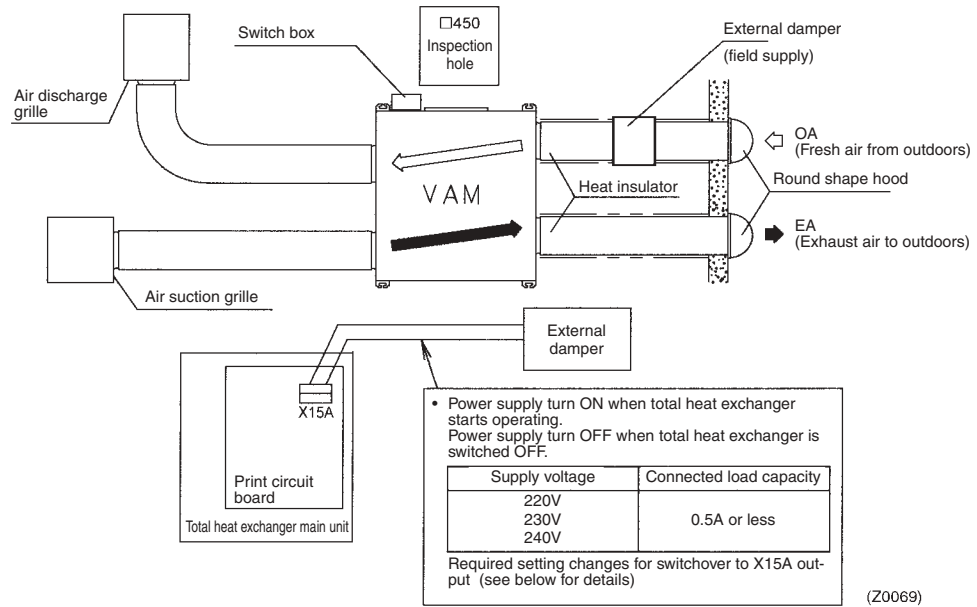

Essential Wiring

1. Connect one end of the harness to the X15A on the print board and the other end to the harness leading to the damper via a closed connector.

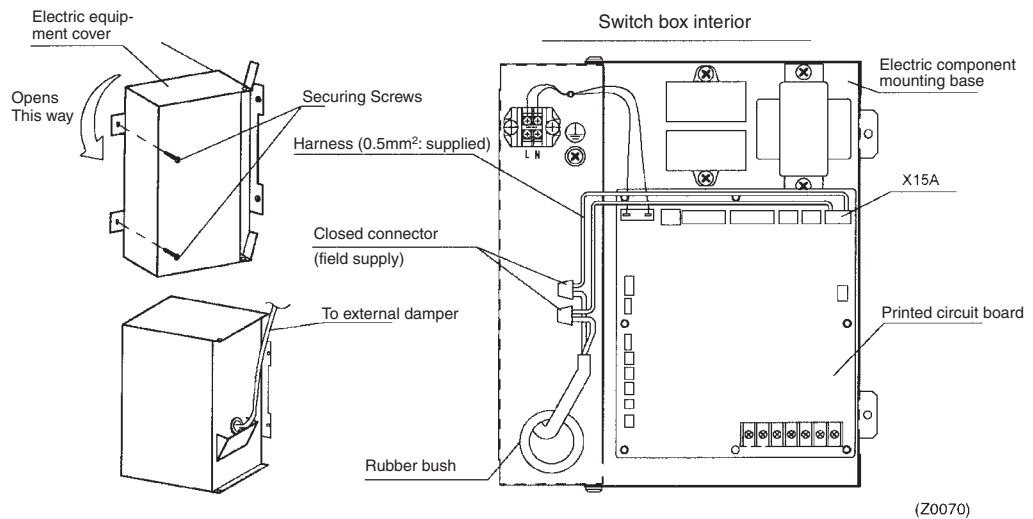

With regard to closed connector, select one that suits wire diameter.

Essential Setting Changes

The X15A output is at the default setting and is not in operation, so the output setting should be changed at the LCD of the remote controller.

- Setting changes should be made in the following way.
 - Mode No.: 18 (group tie up) or 28 (per each unit)
 - Setting switch No.: 3
 - Setting position No.: 03

1.3 Layout of switches on Printed Circuit Board

1.3.1 Printed Circuit Board

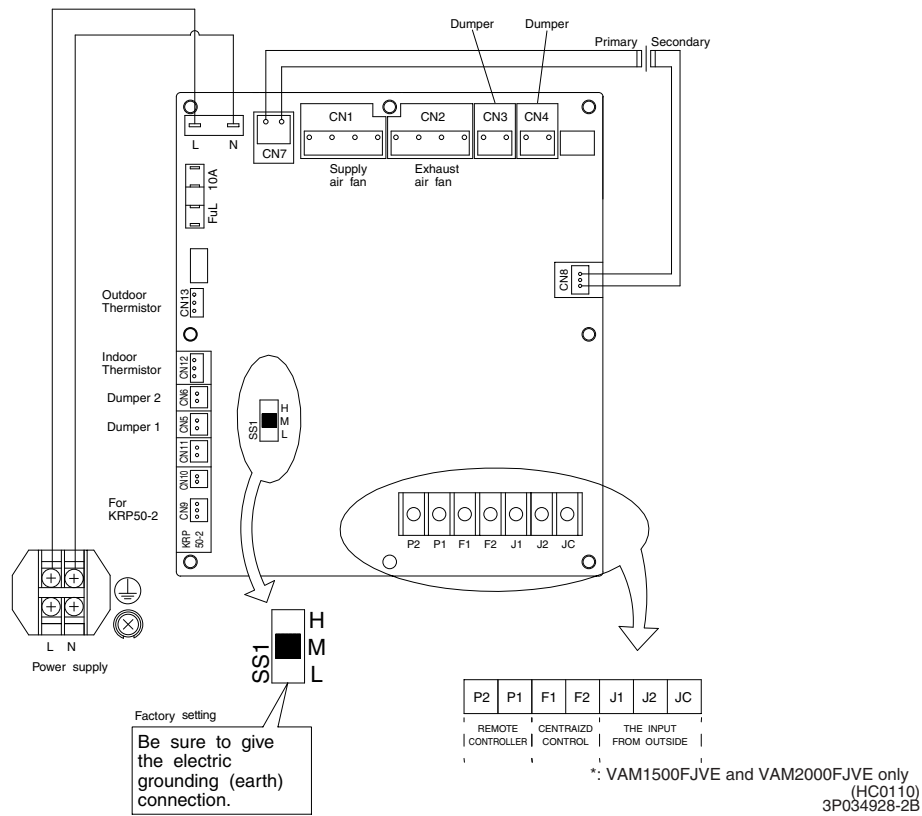

1.3.2 Function of main connection terminal

Terminal No.	Contents of function
Power supply L N TeS1	Single phase 220 – 240 V 50Hz Single phase 220 – 220 V 60Hz Power supply and earth terminal
Remote controller P1 P2	Connection terminal for remote controller for HRV unit. This terminal is used to receive information of the indoor unit for interlocked operation.
Centralized control F1 F2	This terminal is used to receive information when centralized controller is connected.
Input from outside J1 J2 JC	Between terminal no. (J1) ~ (JC) Used for “fresh up operation” by external input. Between terminal no. (J2) ~ (JC) Used for Operation / Stop by external input.

(HC0043)

Part 6

Circuit Operations

1. Circuit Operations	30
1.1 Circuit Configuration	30
1.2 Circuit Functions.....	31

1. Circuit Operations

1.1 Circuit Configuration

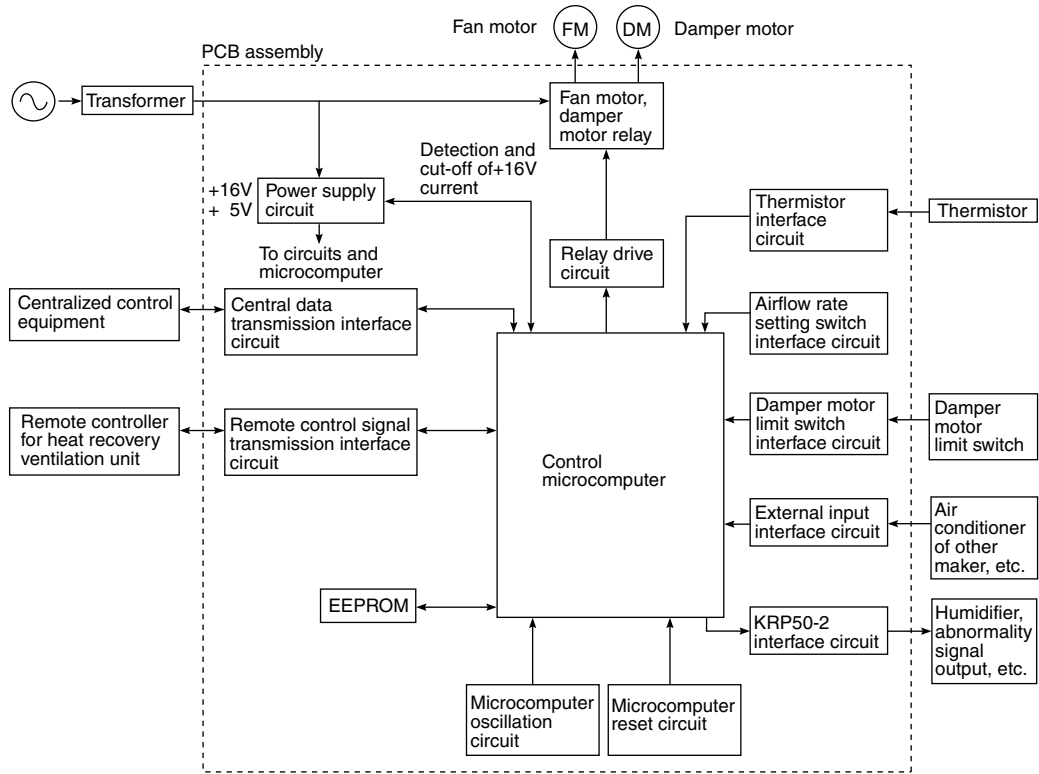

(HL026)

1.2 Circuit Functions

Classification	Circuit	Function
Input/output	Central data transmission interface	Used by centralized control equipment for operation control. Allows control of up to 64 groups of air conditioners and heat recovery ventilation units. Use of KRP2A61 allows zone link operation.
	Remote control data transmission interface	Use of dedicated LCD remote controller allows control of up to 16 heat recovery ventilation units. Also used for linked operation of air conditioners of 2 groups.
	Air conditioner link operation	Connects to remote control line of air conditioner for linked operation.
Output	KRP50-2 interface	Can be used to output signals of operating condition and abnormalities to external equipment or to connect humidifier via KRP50-2.
	Relay drive circuit	Supplies drive voltage to relay coils.
	Fan motor, damper motor relay	Power supply relay for fan motor and damper motor.
Input	Thermistor interface	Uses thermistor (temperature sensor) to detect inside and outside temperatures.
	Airflow rate setting switch interface	Used to set airflow rate of main unit when dedicated remote controller is not used.
	External input interface	Used to control main unit with external contact point. (Freshup, external link operation, etc.)
	Damper limit switch interface	Sends signal of limit switch condition to microcomputer for damper motor cam positioning.
Peripheral Parts	Control microcomputer	Controls entire equipment by varying output according to input condition.
	EEPROM	Stores operating condition and address data.
Microcomputer	Microcomputer reset circuit	Resets microcomputer when power is turned on.
	Microcomputer oscillation circuit	Generates clock frequency for microcomputer operation.
Power Supply	Power transformer	Produces power supply of approx. 26 VAC from 220-240 VAC.
	Power supply circuit	Supplies direct currents (16 VDC, 5 VDC) to control circuits.

Part 7

Troubleshooting

1. Troubleshooting	34
1.1 Error Code Indication.....	34
1.2 Overall Alarm.....	35
1.3 Overall Malfunction.....	36
1.4 Indoor Air Thermistor Error.....	37
1.5 Outdoor Air Thermistor Error.....	38
1.6 Damper System Error (Alarm).....	39
1.7 Damper System Error (Alarm).....	40
1.8 Dedicated LCD Remote Controller.....	41
1.9 Data Transmission Error (Between LCD Remote Controller and Main Unit).....	42
1.10 Data Transmission Error (LCD Remote Controller).....	43
1.11 Data Transmission Error (Between LCD Master Remote Controller and Slave Remote Controller).....	44
1.12 Field Setting Error.....	45
1.13 Overlapping Central Control Address.....	46
1.14 Main Unit PCB Assembly	47
1.15 Dedicated LCD Remote Controller.....	48
1.16 How to Check.....	49
1.17 Thermistor	50
1.18 Power Transformer.....	51
1.19 Damper Motor.....	52

1. Troubleshooting

1.1 Error Code Indication

When an abnormality is generated, take necessary measures by referring to displayed error code. After the cause of abnormality is removed, operate equipment and check proper functioning.

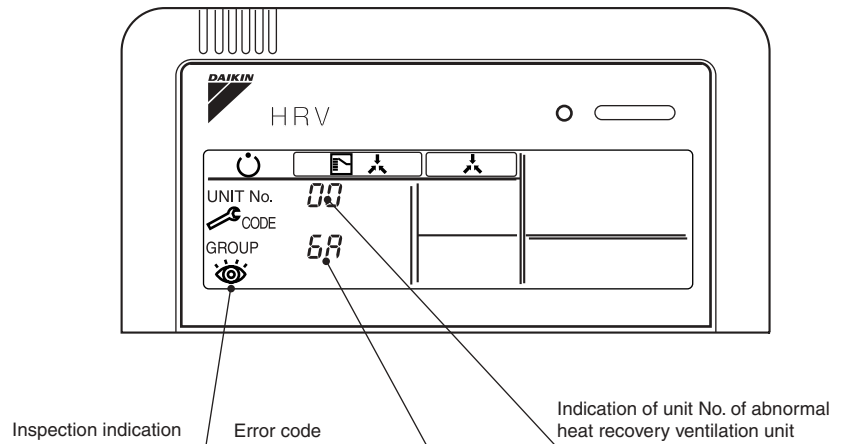

(HL027)

List of malfunction codes displayed by LCD remote controller

LCD Remote Controller Display				Description of Abnormality	Page
Error Code	Operation Lamp	Inspection Indication	Unit No.		
60	ON	OFF	Blinking	Overall alarm	P35
	Blinking	Blinking	Blinking	Overall malfunction	P36
64	ON	OFF	Blinking	Inside air thermistor error	P37
65	ON	OFF	Blinking	Outside air thermistor error	P38
6R	ON	OFF	Blinking	Damper system alarm	P39
6R	Blinking	Blinking	Blinking	Damper system + thermistor error	P40
U5	Blinking	Blinking	Blinking	Data transmission error between LCD remote controller and main unit	P42
U5	OFF	Blinking	OFF	LCD remote controller connection error	P43
U8	OFF	Blinking	OFF	Data transmission error between master-slave LCD remote controllers	P44
UR	OFF	Blinking	OFF	LCD remote controller connection error (no remote controller for air conditioner in air conditioner group)	P45
UC	ON	ON	ON	Overlapping central control address	P46
UE	Blinking	Blinking	Blinking	Transmission error between the unit and centralized controller	—



In case of the malfunction with the shaded error code, the unit still operates. However, be sure to have it inspected and repaired and as soon as possible.

1.2 Overall Alarm

Remote Controller LCD Display

Error Code **60** Inspection — Unit No. 

LED Indication

Remote Controller  Main Unit 

Error Detection Method

Abnormalities are detected based on open circuit in external input terminals (J1-JC).

Error Generating Conditions

When external input terminal (J1-JC) short-circuit during operation (“Overall Alarm” must be set in field setting mode).

Possible Causes

- Faulty external device
- Broken wire
- Faulty control PCB

Troubleshooting

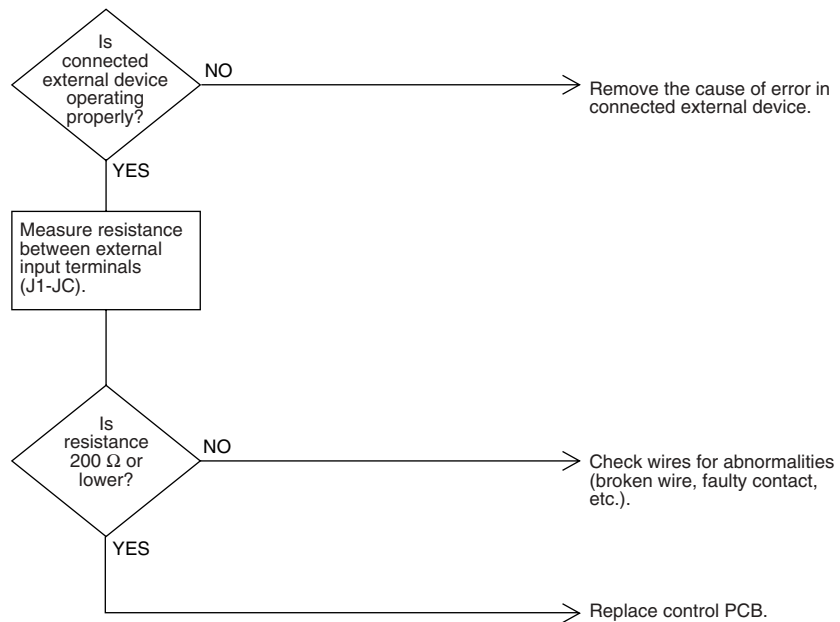



(HF001)

1.3 Overall Malfunction

Remote Controller LCD Display

Error Code **60** Inspection  Unit No. 

LED Indication

Remote Controller  Main Unit 

Error Detection Method

Errors are detected based on open circuit in external input terminals (J1-JC).

Error Generating Conditions

When external input terminal (J1-JC) short-circuit during operation (“Overall Alarm” must be set in field setting mode).

Possible Causes

- Faulty external device
- Broken wire
- Faulty control PCB

Troubleshooting

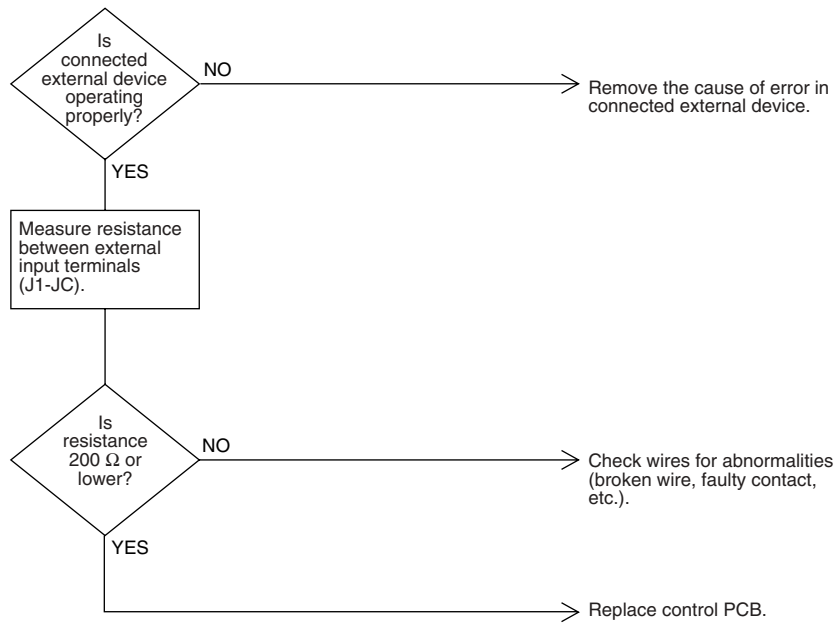

(HF002)

1.4 Indoor Air Thermistor Error

Remote Controller LCD Display	Error Code E4 Inspection — Unit No.
LED Indication	Remote Controller Main Unit
Error Detection Method	Temperature detected by inside air temperature sensor is used to detect errors.
Error Generating Conditions	When value detected by inside air temperature sensor is -40°C or below (open circuit) or 70°C or higher (short-circuit).
Possible Causes	<ul style="list-style-type: none"> ■ Faulty sensor ■ Broken wire ■ Faulty control PCB ■ Faulty contact in connector

Troubleshooting

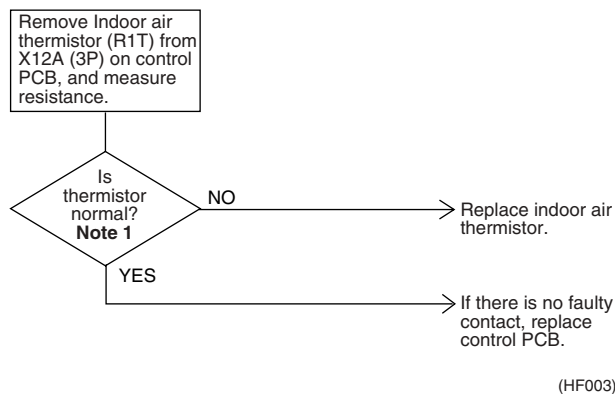

Note:

Note 1:

Refer to the thermistor temperature - resistance conversion table when measuring resistance.

Thermistor temperature - resistance conversion table

Thermistor temperature	Sensor resistance	Thermistor temperature	Sensor resistance
-10°C or less	108kΩ or more	22°C	Approx. 23kΩ
-5°C	Approx. 85kΩ	24°C	Approx. 21kΩ
0°C	Approx. 66kΩ	26°C	Approx. 19kΩ
5°C	Approx. 51kΩ	28°C	Approx. 18kΩ
10°C	Approx. 40kΩ	30°C	Approx. 16kΩ
14°C	Approx. 33kΩ	35°C	Approx. 13kΩ
16°C	Approx. 30kΩ	40°C	Approx. 11kΩ
18°C	Approx. 27kΩ	50°C or more	7kΩ or less
20°C	Approx. 25kΩ		

If measured value deviates significantly from above values, thermistor is faulty.

Use tester to check resistance

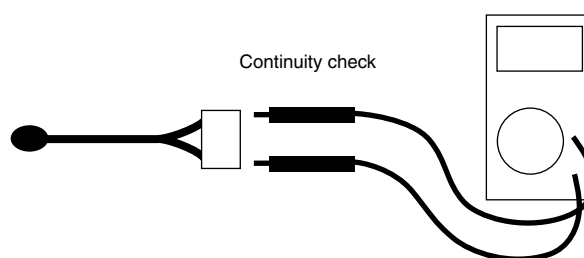



1.5 Outdoor Air Thermistor Error

Remote Controller LCD Display

Error Code **65** Inspection — Unit No. 

LED Indication

Remote Controller  Main Unit 

Error Detection Method

Temperature detected by outside air temperature sensor is used to detect errors.

Error Generating Conditions

When value detected by outside air temperature sensor is -40°C or below (open circuit) or 70°C or higher (short-circuit).

Possible Causes

- Faulty sensor
- Broken wire
- Faulty control PCB
- Faulty contact in connector

Troubleshooting

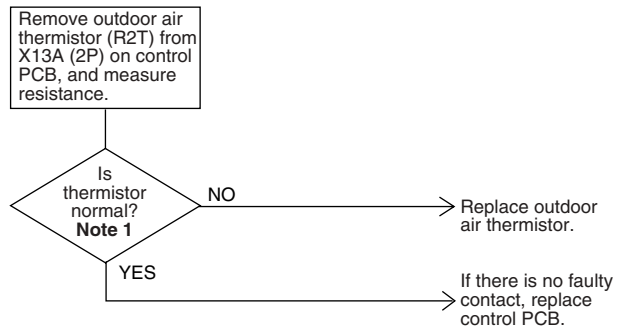

(HF004)



Note:

Note 1:

Refer to the thermistor temperature - resistance conversion table when measuring resistance.

Thermistor temperature - resistance conversion table

Thermistor temperature	Sensor resistance	Thermistor temperature	Sensor resistance
-10°C or less	108k Ω or more	22°C	Approx. 23k Ω
-5°C	Approx. 85k Ω	24°C	Approx. 21k Ω
0°C	Approx. 66k Ω	26°C	Approx. 19k Ω
5°C	Approx. 51k Ω	28°C	Approx. 18k Ω
10°C	Approx. 40k Ω	30°C	Approx. 16k Ω
14°C	Approx. 33k Ω	35°C	Approx. 13k Ω
16°C	Approx. 30k Ω	40°C	Approx. 11k Ω
18°C	Approx. 27k Ω	50°C or more	7k Ω or less
20°C	Approx. 25k Ω		

If measured value deviates significantly from above values, thermistor is faulty.

Use tester to check resistance

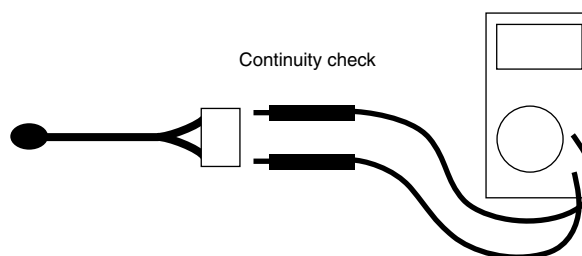



(HL028)

1.6 Damper System Error (Alarm)

Remote Controller LCD Display

Error Code **ER** Inspection — Unit No. 

LED Indication

Remote Controller  Main Unit 

Error Detection Method

Measurement of damper motor limit ON/OFF time.

Error Generating Conditions

- When damper motor limit switch 1 (or 2) remains ON (or OFF) for more than a certain time duration after ventilation mode is changed.
- When damper motor limit switch 1 (or 2) repeats ON/OFF operations after damper motor 1 (or 2) stops.

Possible Causes

- Faulty damper motor or limit switch
- Broken wire in cable
- Faulty contact in connector (including relay connector)
- Faulty control PCB assembly

Troubleshooting

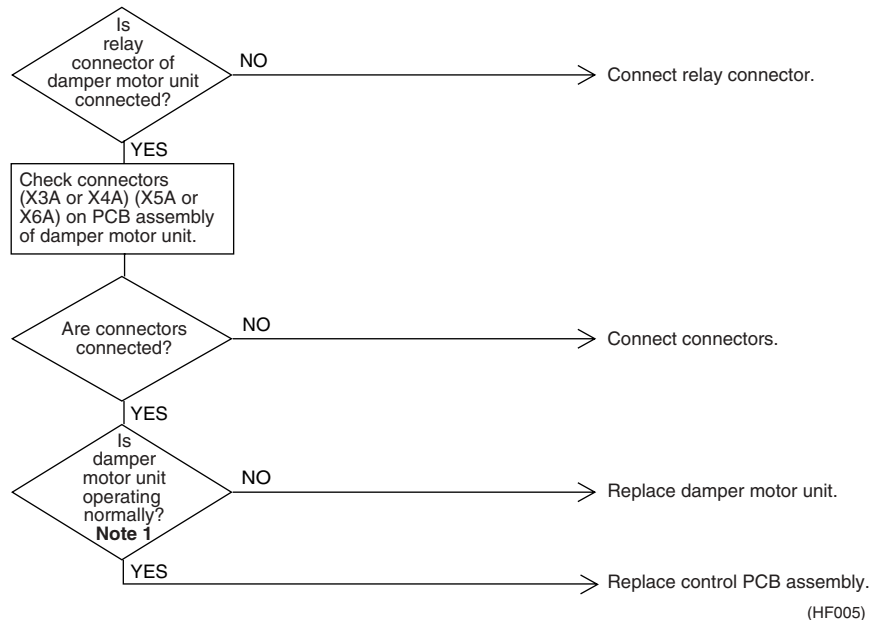

Note: Note 1:

- Place tester probes on connectors of limit switch. Move switch by hand and check continuity. If tester indicates 0Ω when limit switch turns on, and infinity when it turns off, limit switch is normal.
- Place tester probes on connectors of damper motor and check resistance. If tester indicates approx. 17 k Ω in 200-V model, damper motor is normal.

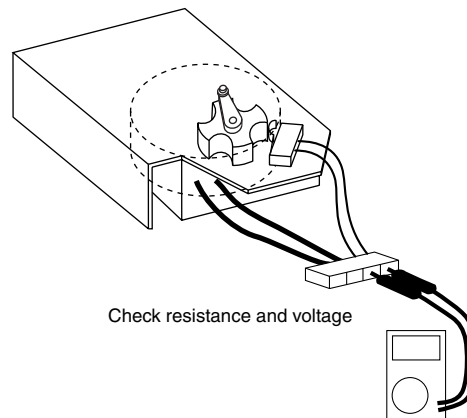

(HL029)

1.7 Damper System Error (Alarm)

Remote Controller LCD Display	Error Code 6A Inspection Unit No.
LED Indication	Remote Controller Main Unit
Error Detection Method	Measurement of damper motor limit switch ON/OFF time and temperatures detected by outdoor and indoor air thermistor.
Error Generating Conditions	<ul style="list-style-type: none"> ■ When damper system error (alarm) and indoor (or outdoor) thermistor error are generated at the same time. ■ When damper system error (alarm) occurs and values of indoor and outdoor air thermistor meet frost conditions.
Possible Causes	<ul style="list-style-type: none"> ■ Faulty damper motor or limit switch ■ Faulty indoor air thermistor ■ Faulty outdoor air thermistor ■ Frosting ■ Broken wire in cable ■ Faulty contact in connector (including relay connector) ■ Faulty control PCB assembly

Troubleshooting

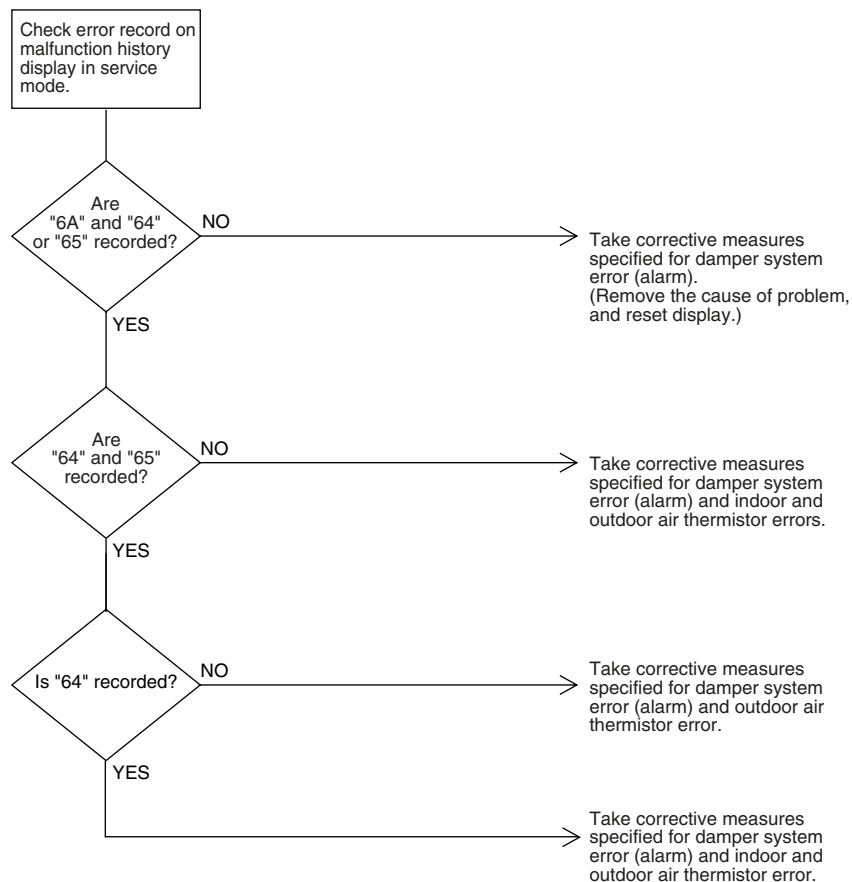

(HF006)

1.8 Dedicated LCD Remote Controller

When "88" remains on remote controller display.

Error Detection Method

When "88" remains on remote controller display.

Error Generating Conditions

Possible Causes

- Master-slave setting of remote controller
- Remote controller PCB assembly error
- Main unit PCB assembly error

Troubleshooting

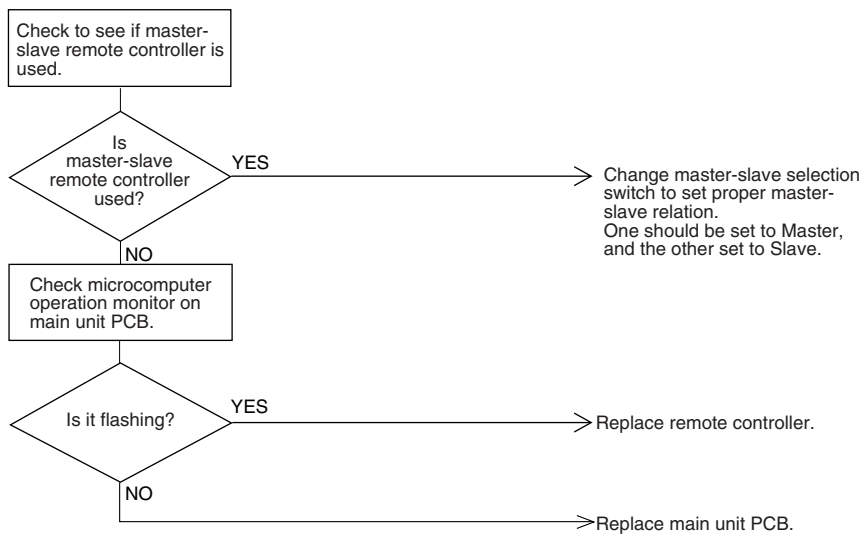

(HF007)

Dedicated Remote Controller

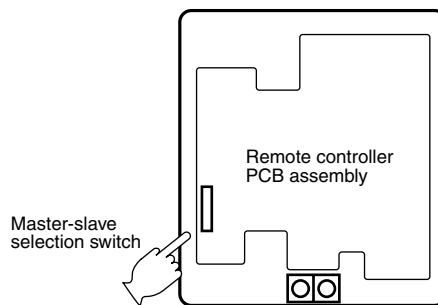

(HL030)

Main Unit PCB

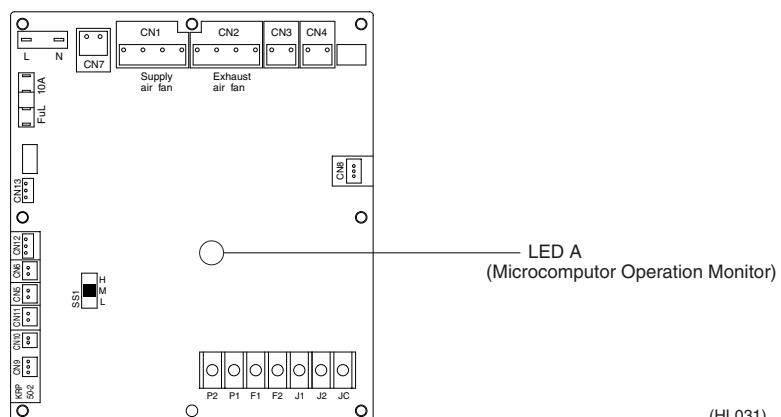

(HL031)

1.9 Data Transmission Error (Between LCD Remote Controller and Main Unit)

Remote Controller LCD Display	Error Code <i>U5</i> Inspection Unit No.
LED Indication	Remote Controller Main Unit
Error Detection Method	Microcomputer checks if data is transmitted properly between main unit and remote controller.
Error Generating Conditions	When data transmission is not performed correctly for a certain time period.
Possible Causes	<ul style="list-style-type: none"> ■ Faulty connection of remote controller cable ■ Faulty remote controller cable ■ External factor (noise, etc.)

Troubleshooting

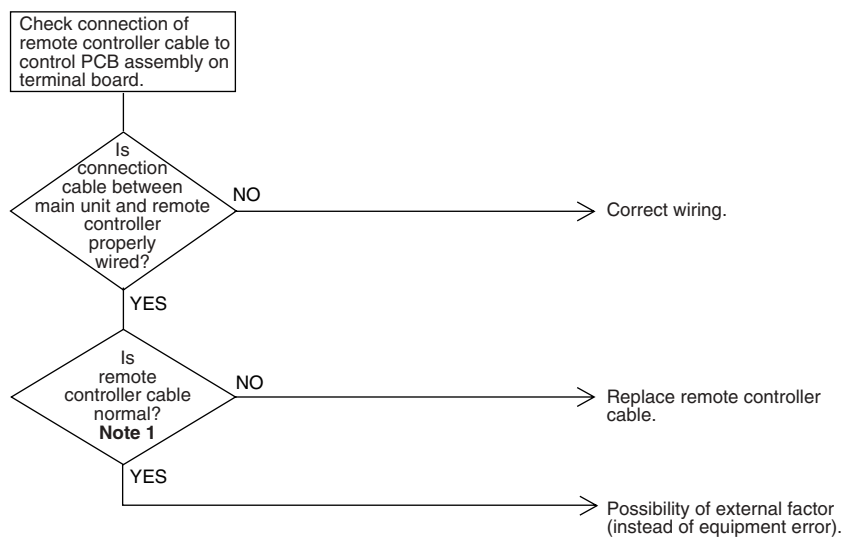

(HF008)



Note: **Note 1:**

1. Use tester to check continuity of remote controller cable.
 - Disconnect cable from main unit terminal board and remote controller terminal board. Measure resistance between wires in cable. Resistance should be ∞ M Ω (infinity).
2. Use tester to check voltage at terminal board.
 - Check with power turned on.
 - With remote controller cable disconnected, voltage between P1 and P2 on terminal board should be approx. 16 VDC. If measured value is not approx. 16 VDC, PCB assembly is faulty.
 - Connect remote controller cable and disconnect remote controller. Voltage at the end of remote controller cable should be approx. 16 VDC. If measured value is not 16 VDC, remote controller cable is faulty.
 - Connect remote controller cable and remote controller. Voltage between P1 and P2 on remote controller terminal should be approx. 16 VDC. If measured value is not 16 VDC, remote controller is faulty.

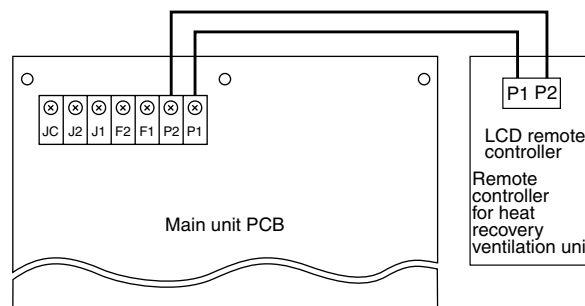



(HL032)

1.10 Data Transmission Error (LCD Remote Controller)

Remote Controller LCD Display

Error Code **U5** Inspection  Unit No. 

LED Indication

Remote Controller  Main Unit 

Error Detection Method

Microcomputer checks if data is transmitted properly between main unit and remote controller.

Error Generating Conditions

When data transmission is not performed correctly for a certain time period.

Possible Causes

- Erroneous connection
- Faulty remote controller setting
- Faulty remote controller

Troubleshooting

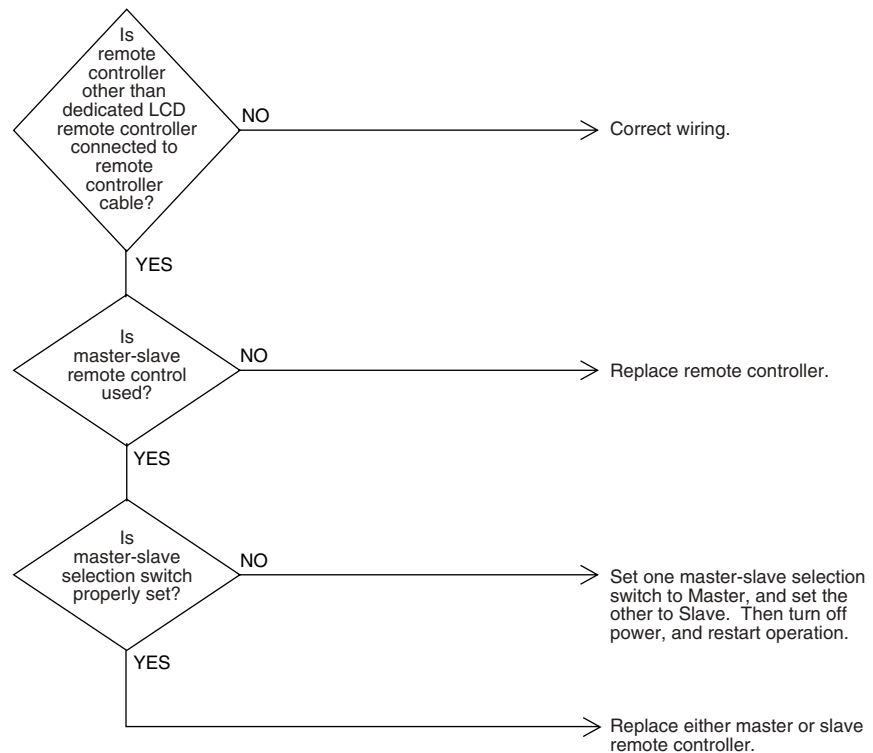

(HF009)

1.11 Data Transmission Error (Between LCD Master Remote Controller and Slave Remote Controller)

Remote Controller LCD Display	Error Code <i>U8</i> Inspection Unit No. ●
LED Indication	Remote Controller ● Main Unit
Error Detection Method	Microcomputer checks if data is transmitted properly between master-slave remote controller.
Error Generating Conditions	When data transmission is not performed correctly for a certain time period.
Possible Causes	<ul style="list-style-type: none"> ■ Faulty remote controller setting ■ Faulty remote controller

Troubleshooting

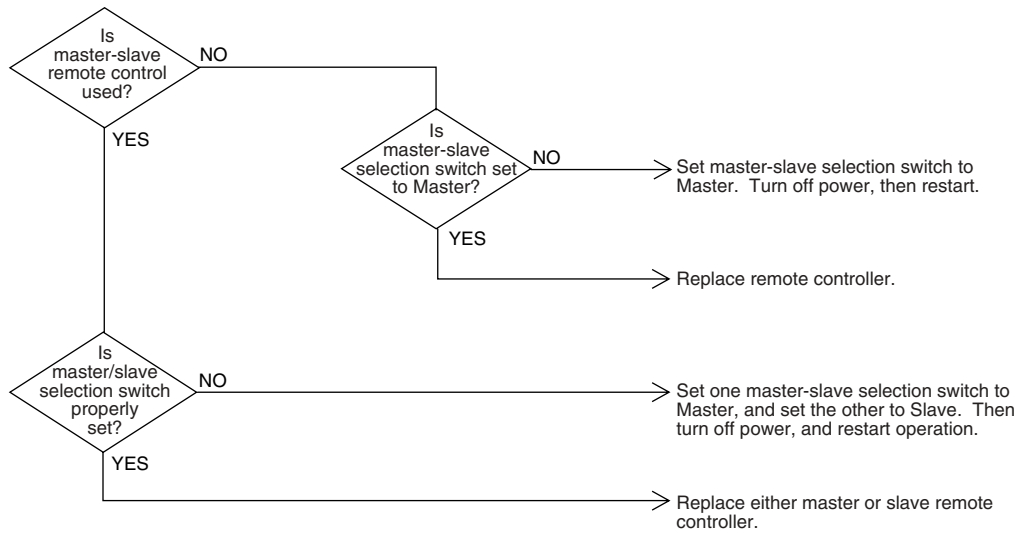

(HF010)

1.12 Field Setting Error

Remote Controller LCD Display

Error Code *UR* Inspection  Unit No. ●

LED Indication

Remote Controller ● Main Unit 

Error Detection Method

Error Generating Conditions

Possible Causes

- Faulty combination of remote controller
- More than 16 units connected to remote controller cable.
- Faulty remote controller

Troubleshooting

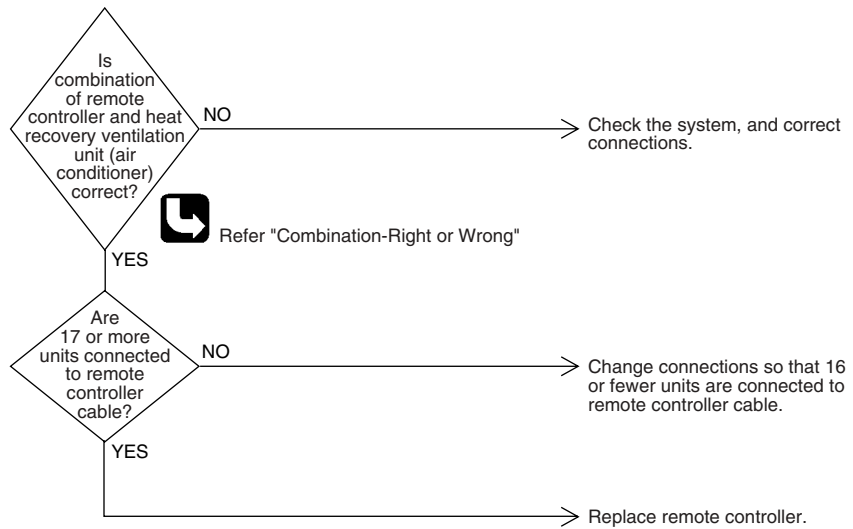

(HF011)

<Combination-Right or Wrong>



Main body	Remote controller	Right/Wrong
Heat recovery ventilation unit only	Heat recovery ventilation unit	Right
Heat recovery ventilation unit only	Heat recovery ventilation unit + air-conditioner	Wrong
Heat recovery ventilation unit only	Air conditioner	Right
Heat recovery ventilation unit + air-conditioner	Heat recovery ventilation unit	Wrong
Heat recovery ventilation unit + air-conditioner	Heat recovery ventilation unit + air-conditioner	Right
Heat recovery ventilation unit + air-conditioner	Air-conditioner	Right

1.13 Overlapping Central Control Address

Remote Controller LCD Display

Error Code **UC** Inspection  Unit No. 

LED Indication

Remote Controller  Main Unit 

Error Detection Method

Remote controller microcomputer checks for double-setting of addresses.

Error Generating Conditions

When same address is set to two or more units.

Possible Causes

- Overlapping of central control address
- Faulty remote control

Troubleshooting

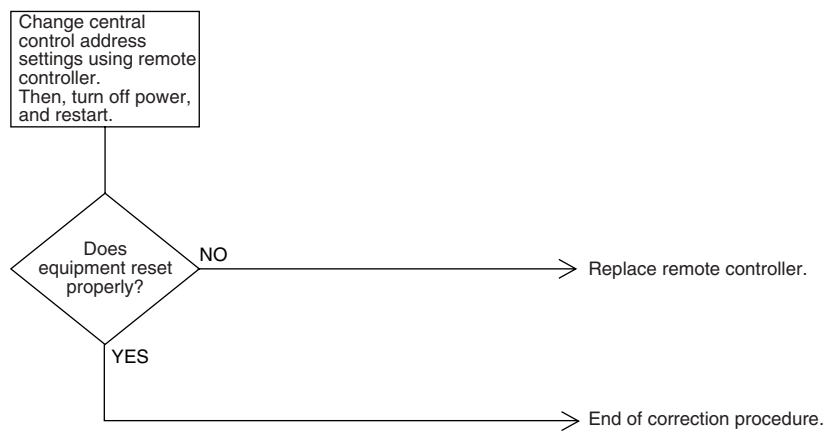

(HF012)

1.14 Main Unit PCB Assembly

Error Detection Method	Check microcomputer operation monitor.
Error Generating Conditions	When main unit PCB assembly does not operate. When communication circuit errors.
Possible Causes	Fuse (excess current) Power transformer Noise Main unit PCB

Troubleshooting

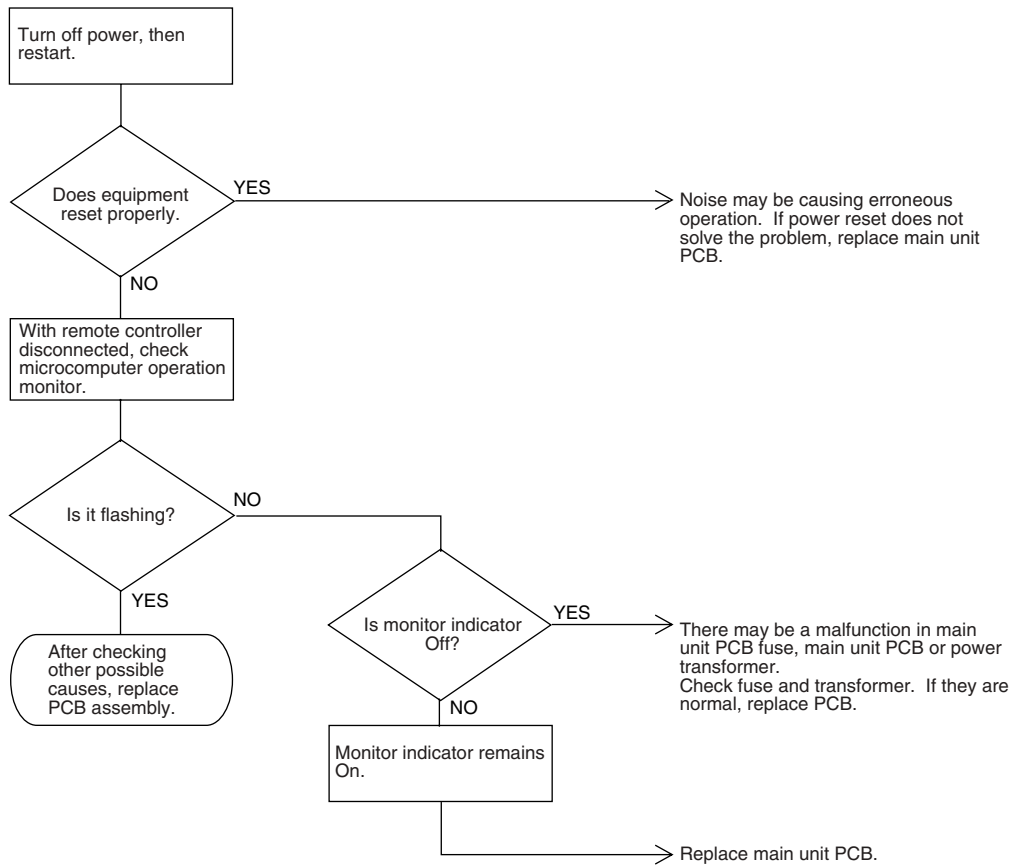

(HF013)

Main unit PCB

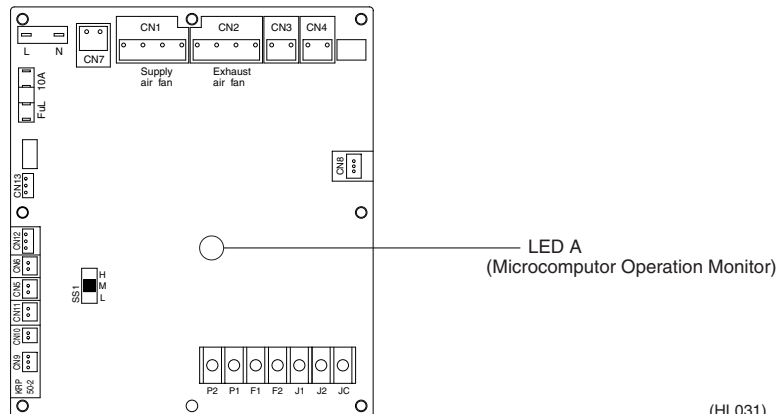

(HL031)

1.15 Dedicated LCD Remote Controller

When no indication is displayed on remote controller

Error Detection Method

Check to see if remote controller displays indication.

Error Generating Conditions

Possible Causes

Troubleshooting

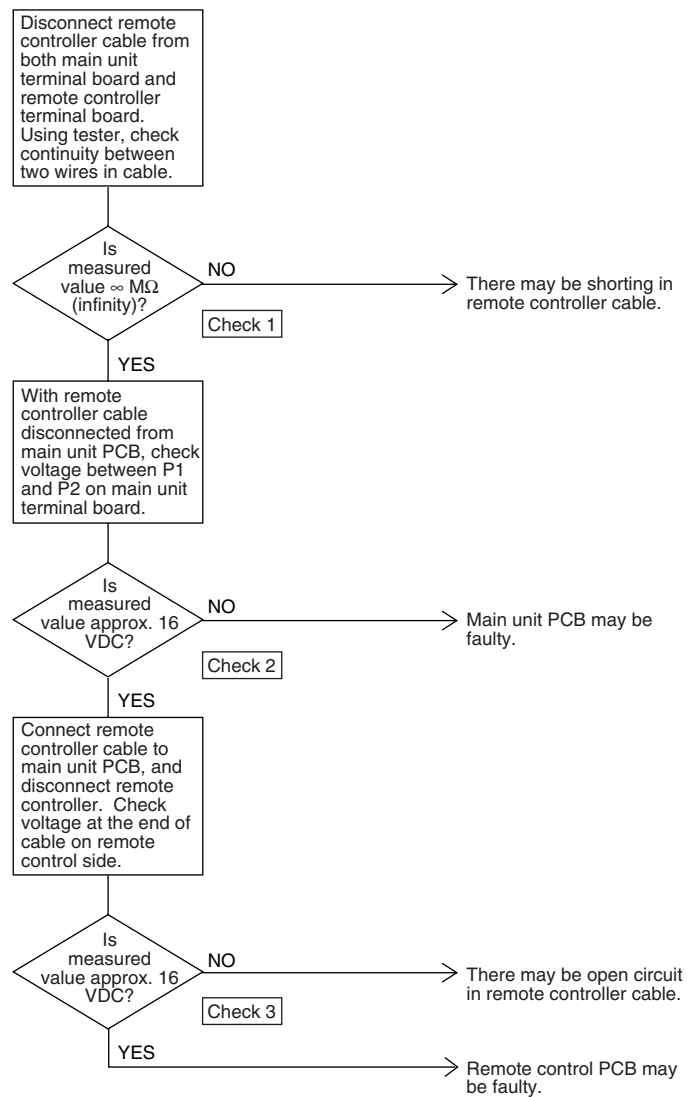

(HF014)



Check 1, 2, 3 : Refer to page 49

1.16 How to Check

Check 1

Dedicated LCD remote controller (Option)

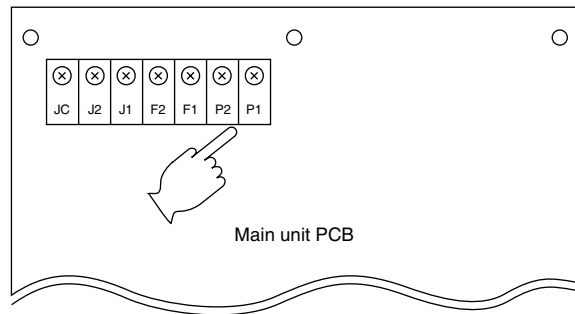

(HL034)

Check 2

Dedicated LCD remote controller (Option)

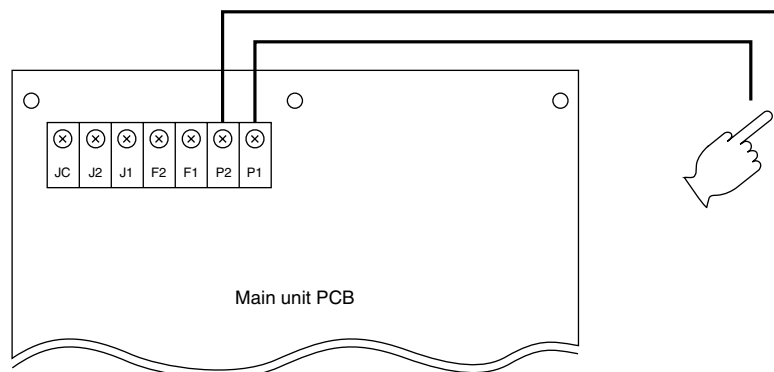

(HL035)

Check 3

Dedicated LCD remote controller (Option)

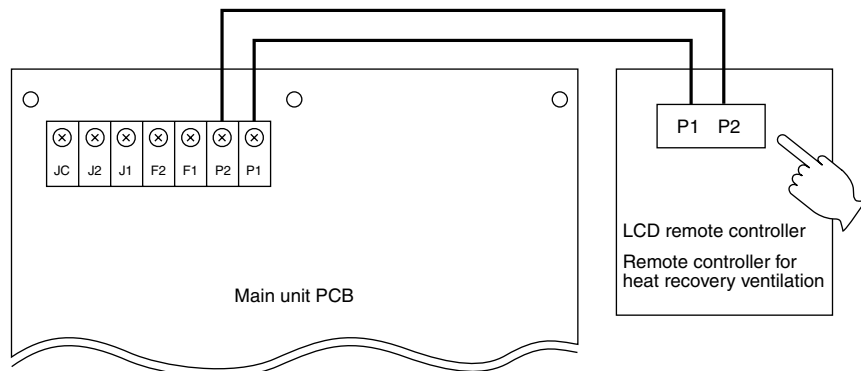

(HL036)

1.17 Thermistor

Error Detection Method Remove thermistor and check resistance with tester.

Error Generating Conditions

- Possible Causes**
- Faulty thermistor
 - Broken wire
 - Faulty control PCB
 - Faulty contact in connector

Troubleshooting

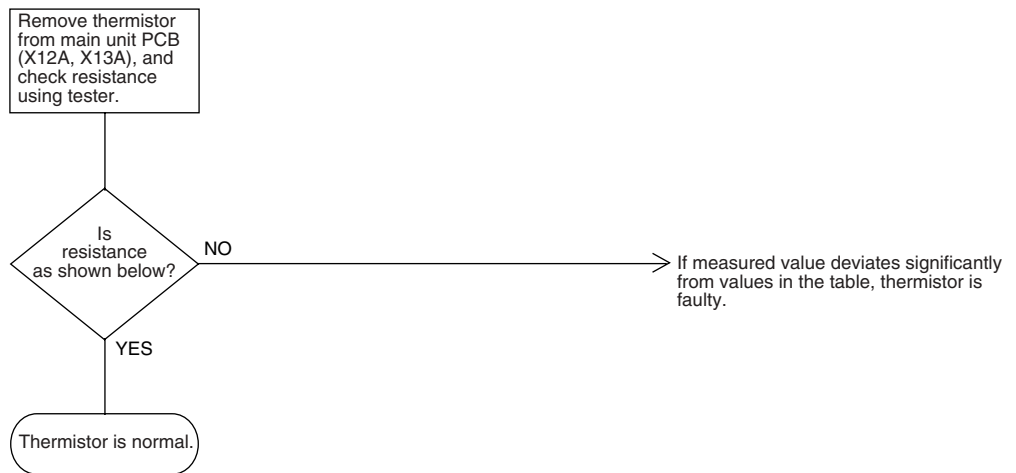

(HF015)



Note: Refer to the thermistor temperature - resistance conversion table when measuring resistance.

Thermistor temperature - resistance conversion table

Thermistor temperature	Sensor resistance	Thermistor temperature	Sensor resistance
-10°C or less	108kΩ or more	22°C	Approx. 23kΩ
-5°C	Approx. 85kΩ	24°C	Approx. 21kΩ
0°C	Approx. 66kΩ	26°C	Approx. 19kΩ
5°C	Approx. 51kΩ	28°C	Approx. 18kΩ
10°C	Approx. 40kΩ	30°C	Approx. 16kΩ
14°C	Approx. 33kΩ	35°C	Approx. 13kΩ
16°C	Approx. 30kΩ	40°C	Approx. 11kΩ
18°C	Approx. 27kΩ	50°C or more	7kΩ or less
20°C	Approx. 25kΩ		

If measured value deviates significantly from above values, thermistor is faulty.
Use tester to check resistance

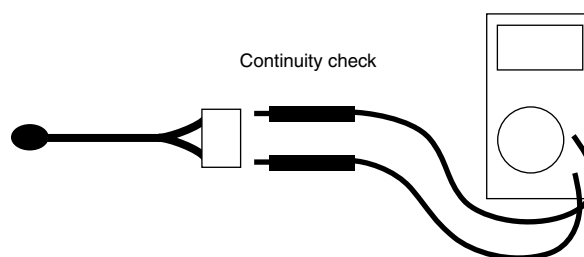

(HL028)

1.18 Power Transformer

Error Detection Method

Check resistance and voltage with tester, and insulation resistance with megger.

Error Generating Conditions

Possible Causes

Troubleshooting

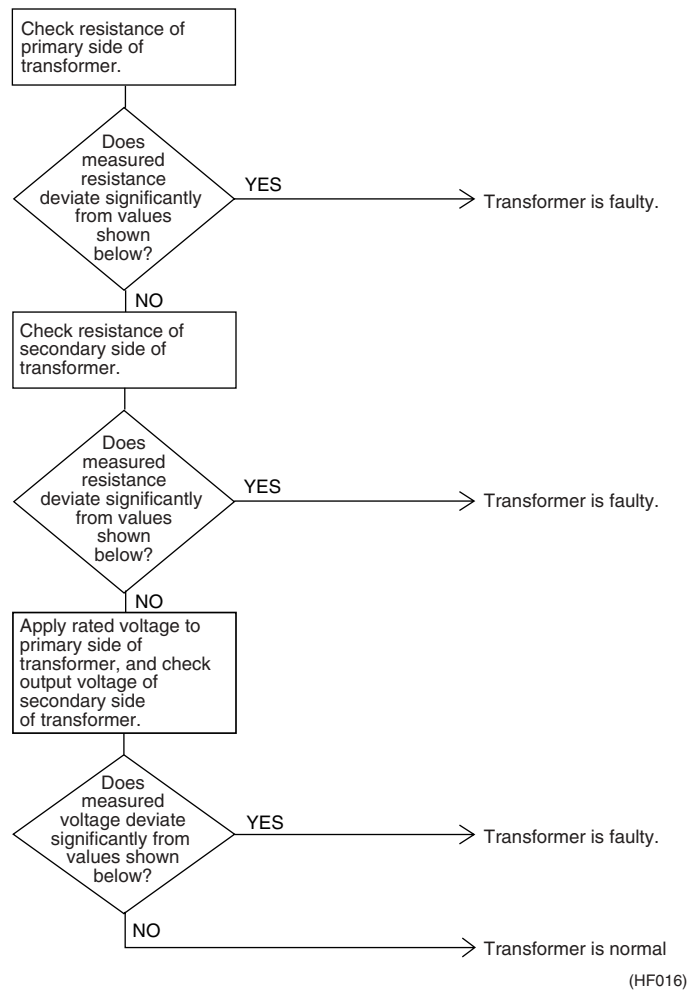

- Resistance of primary side of transformer: approx. 140Ω
- Resistance of secondary side of transformer: approx. 1.9Ω
- Voltage at secondary side of transformer when rated voltage is applied to primary side: approx. 26 VAC
- Insulation resistance between primary side of transformer and case: $100\text{ M}\Omega$ or higher
- Insulation resistance between secondary side of transformer and case: $100\text{ M}\Omega$ or higher
- Insulation resistance between primary side and secondary side of transformer: $100\text{ M}\Omega$ or higher

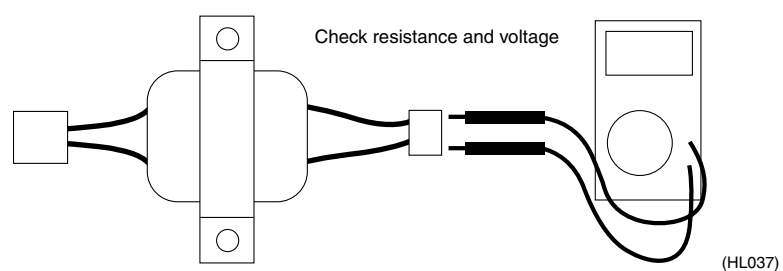

1.19 Damper Motor

Error Detection Method	Check damper motor and limit switch when damper motor does not operate.
Error Generating Conditions	
Possible Causes	
Troubleshooting	

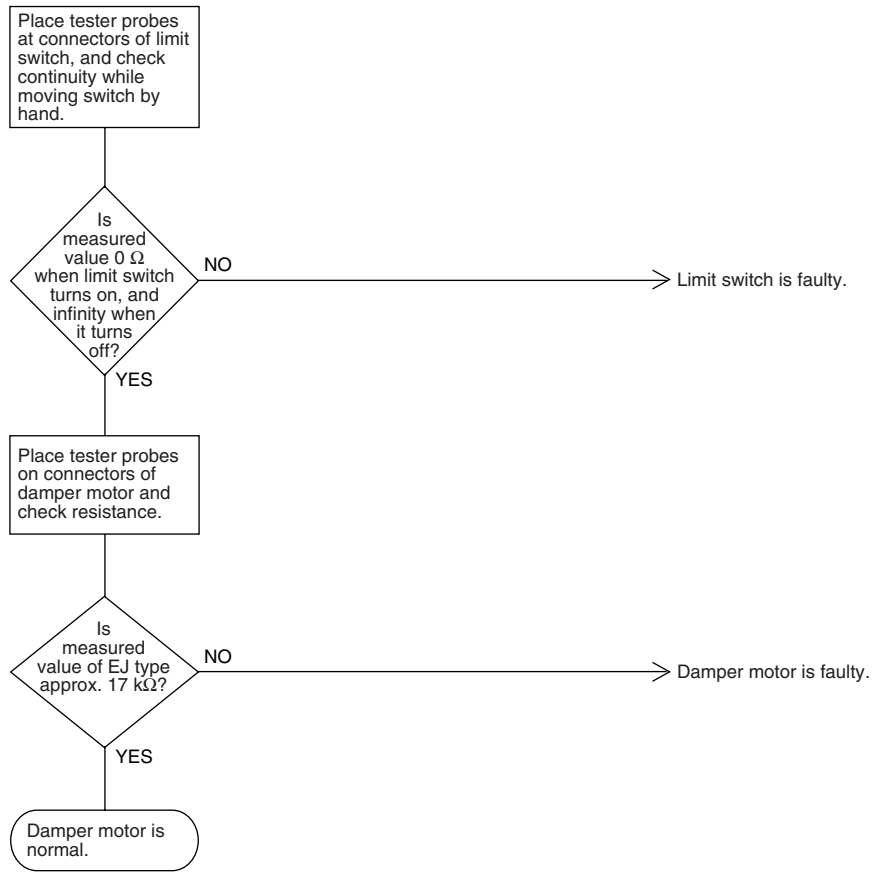

(HF017)

Check resistance and voltage — DAMPER MOTOR

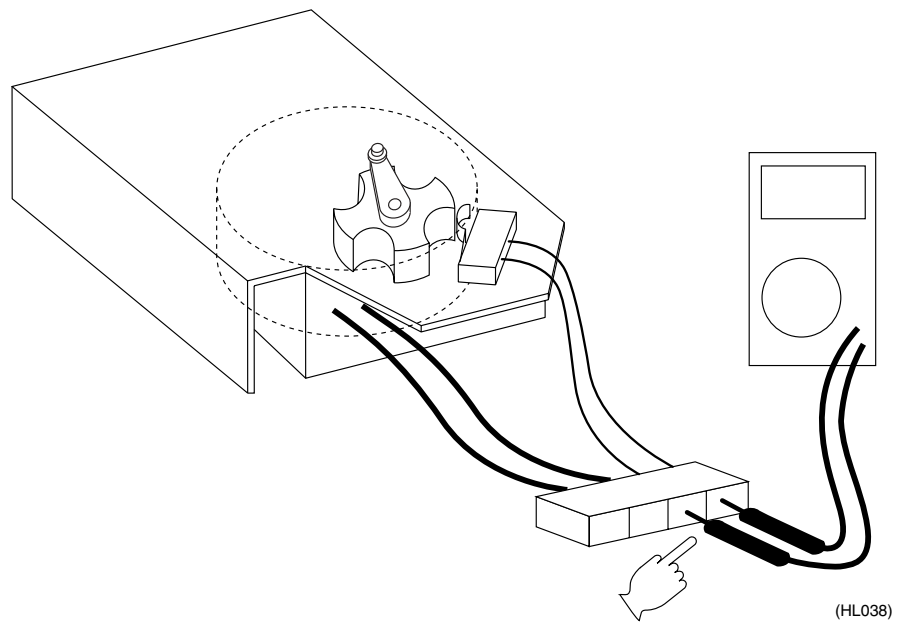

(HL038)

Part 8 Supplementary Explanation

1. Supplementary Explanation	54
1.1 Field Setting, Service Mode Operation.....	54

1. Supplementary Explanation

1.1 Field Setting, Service Mode Operation

1.1.1 Field Setting

Initial setting (mode Nos. 17, 27, 18, 28)

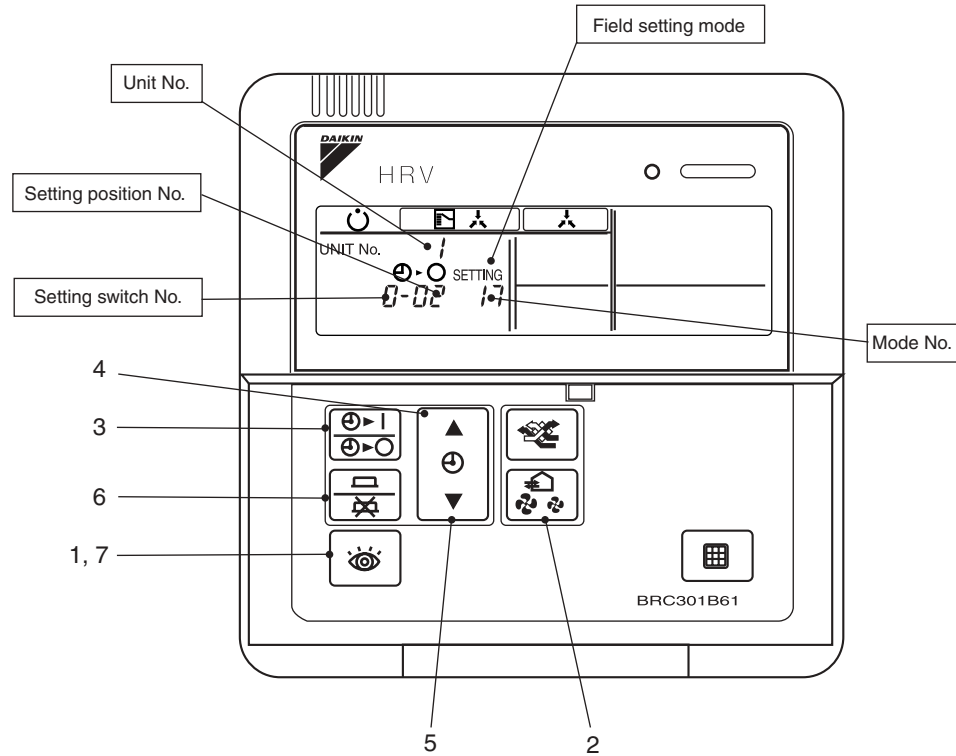

(HL039)

Step 1	With equipment in normal mode, press the button for more than 4 seconds to enter field setting mode.
Step 2	Mode No.: UP ↔ Mode No.: DOWN Use [MODE] and [AIR VOLUME] to select desired mode No.
Step 3	To setting heat recovery ventilation units by group, press button and select desired unit No.
Step 4	Press button to select desired setting switch No.
Step 5	Press button to select desired setting position No.
Step 6	Press button to enter settings.
Step 7	Press button to return to normal mode.

**Centralized control
group No. setting
(Mode No. 00)
Setting of
Individual No.
(Mode No. 30)**

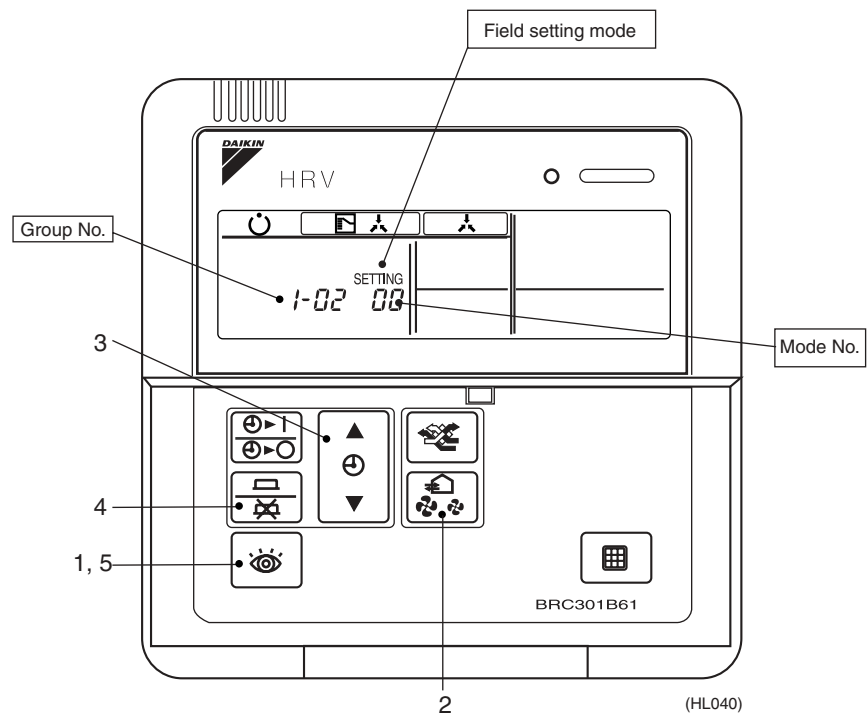

Step 1	With equipment in normal mode, press the button for more than 4 seconds to enter field setting mode.
Step 2	Mode No.: UP ↔ Mode No.: DOWN Use [MODE] and [AIR VOLUME] to select mode No.00 (30).
Step 3	Press or button to select Group No.
Step 4	Press button once to enter settings.
Step 5	Press button to return to normal mode.

1.1.2 Service Mode Operation



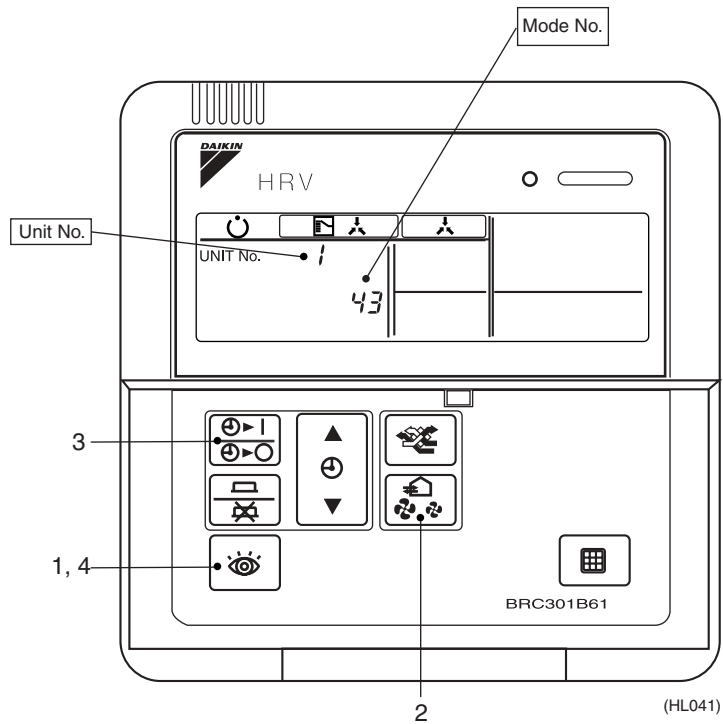



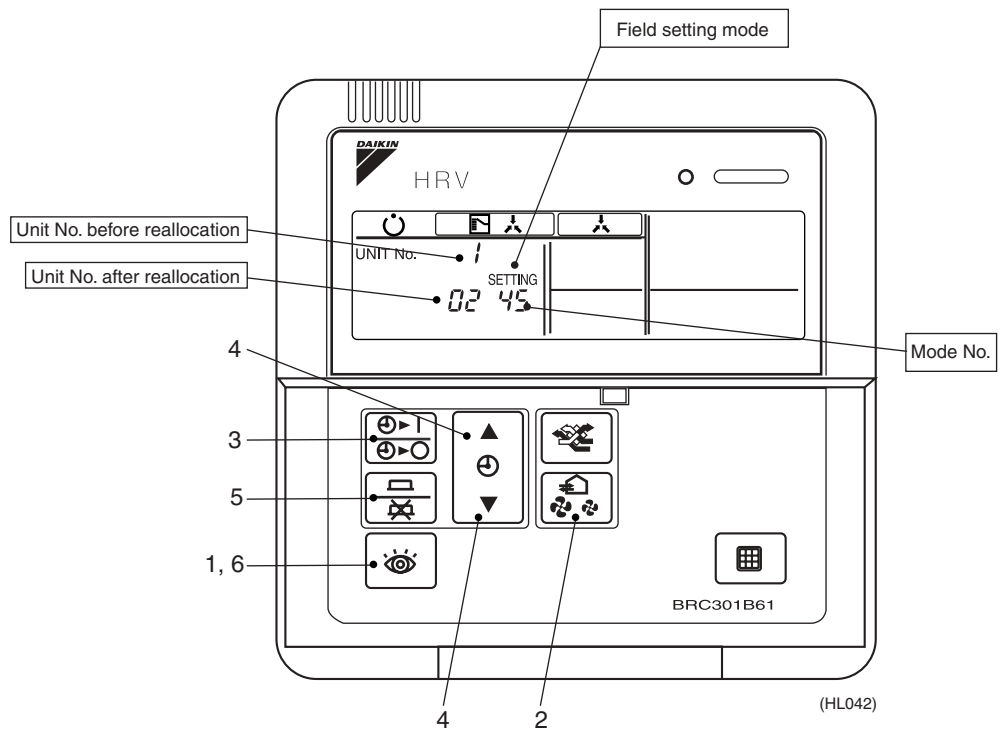

Turn on the forced fan (Mode No.43)



Step 1	With equipment in field setting mode, press the button for more than 4 seconds to enter service mode.
Step 2	Mode No.: UP ↔ Mode No.: DOWN Use [MODE] and [AIR VOLUME] to select mode No.43.
Step 3	Use to select desired Unit No.
Step 4	Press button to return to normal mode.

Unit No. reallocation (Mode No.45)



Step 1	With equipment in field setting mode, press the  button for more than 4 seconds to enter service mode.
Step 2	 Mode No.: UP ↔  Use [MODE] and [AIR VOLUME] to select mode No.45.
Step 3	Use  to select setting Unit No.
Step 4	Press  or  button to select Unit No. after reallocation.
Step 5	Press  button once to enter settings.
Step 6	Press  button to return to normal mode.

1.1.3 Operation Changeover Control

For group control of systems containing heat recovery ventilation units and air conditioners (VRV system), remote controllers of air conditioners are connected with remote controllers of new heat recovery ventilation units. In such system, both remote controllers display “Operation changeover control” according to the ON/OFF of cooling/heating selection privilege.

The following diagram shows the display ON/OFF condition determined by the unit combination.

Example of “Operation changeover control” display

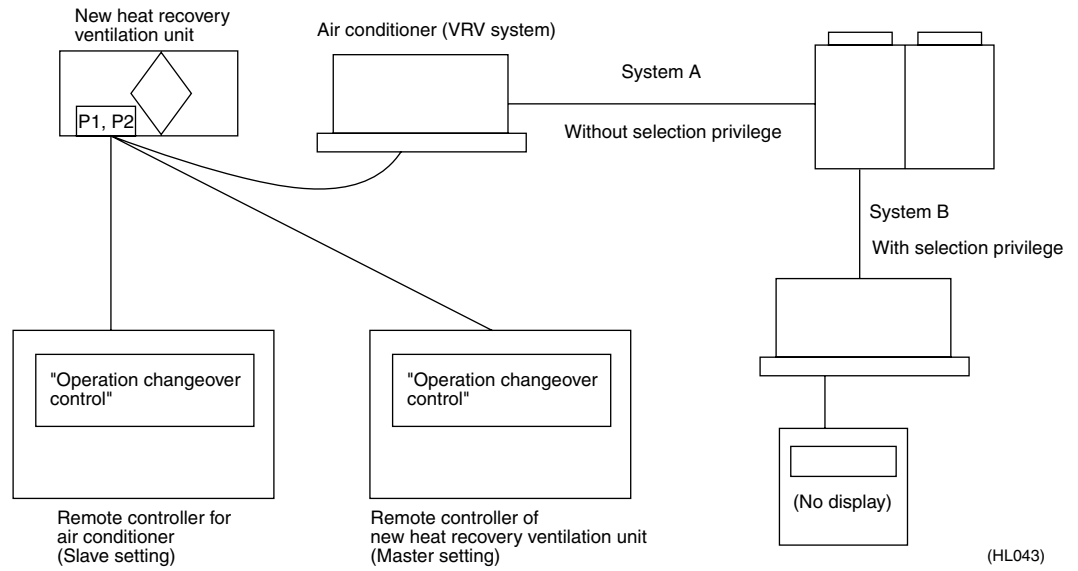

Display ON/OFF condition by connection type and cooling/heating selection privilege

Connection type	“Operation changeover control” display	
Heat recovery ventilation unit only	No display	
Heat recovery ventilation unit + Air conditioner (VRV system)	Cooling/heating selection privilege not set	Flashing (Note 1)
	Cooling/heating selection privilege ON	No display
	Cooling/heating selection privilege OFF	Display



Note:

Note 1:

Only master remote controller can display flashing “Operation changeover control” when cooling/heating selection privilege is not set.

1.1.4 Field Setting

The following shows the procedure for field setting using remote controller of new heat recovery ventilation unit.

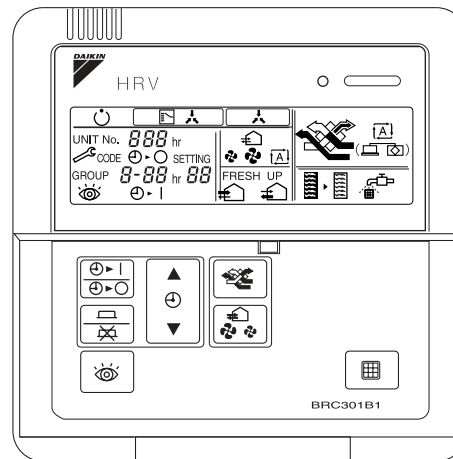

(HL044)

List of field setting mode Nos.

Centralized control group No. setting	00
General setting	10-29
Centralized control group No. setting (group)	30
Error record display	40
Sensor data	41
Forced fan ON	43
Individual setting	44
Unit No. reallocation	45

Step 1	To field setting mode	Press for more than 4 sec.
Step 2	Mode No. selection 1	[Mode (00-30)] → [Mode (40-49)] → [Mode (50-59)] (Press for more than 4 sec.) (Press for more than 4 sec.)
Step 3	Mode No. selection 2	Mode No.: UP ←→ Mode No.: DOWN
Step 4	Switch No. selection	(▲) Switch No. selection
Step 5	Position selection	(▼) Position selection
Step 6	Position enter	Enters currently selected position.
Step 7	To normal mode	Exits field setting mode and enters normal mode.

In group control, use to select unit No.

1.1.5 LCD and Operation Panel (Reference Information)

The following shows the operation panel and LCD of remote controller of new heat recovery ventilation unit.

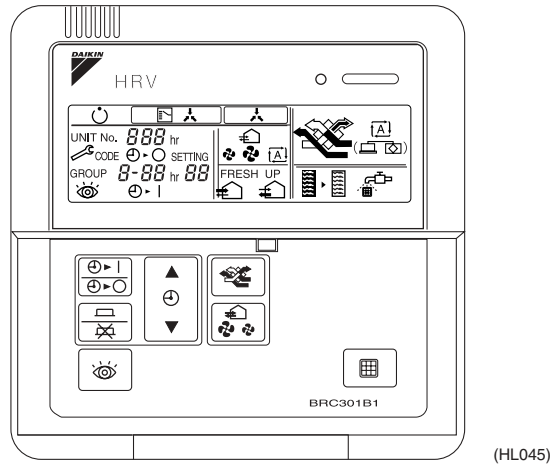

LCD

LCD is equipped with a new function that graphically displays currently selected ventilation mode, as shown below.

(Ventilation mode: Auto)	Total heat exchange ventilation mode	(HL046)
	Normal ventilation mode	(HL047)
	Display OFF in automatic ventilation mode	(HL048)
(Ventilation mode: Total heat exchange)		(HL049)
(Ventilation mode: Normal)	Normal ventilation mode	(HL050)

Display can be turned off using field setting 19 (29) - 7.

1.1.6 Ventilation Volume (Freshup)

Ventilation volume (Freshup) setting changes as follows.

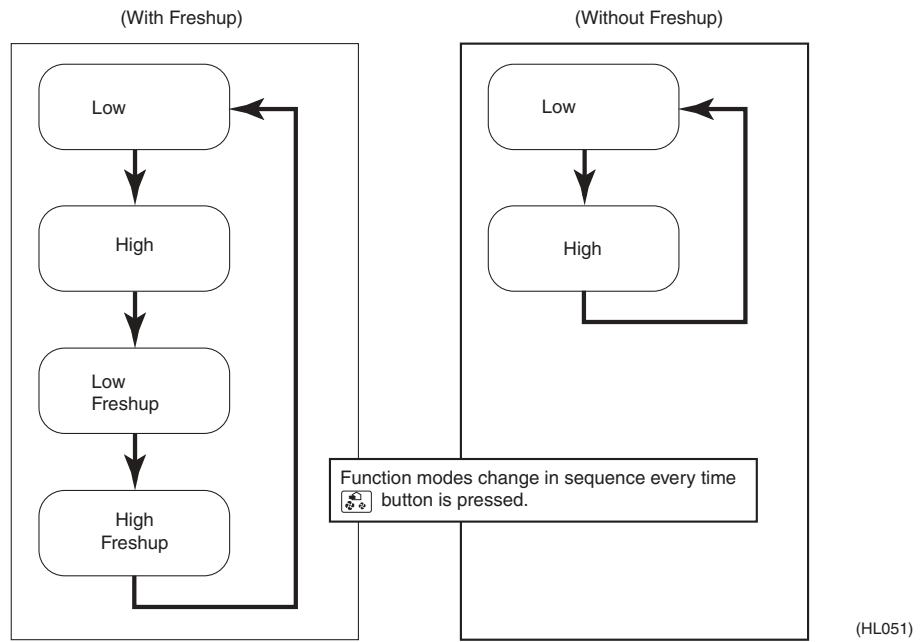

Inspection

Inspection operation is shown below.

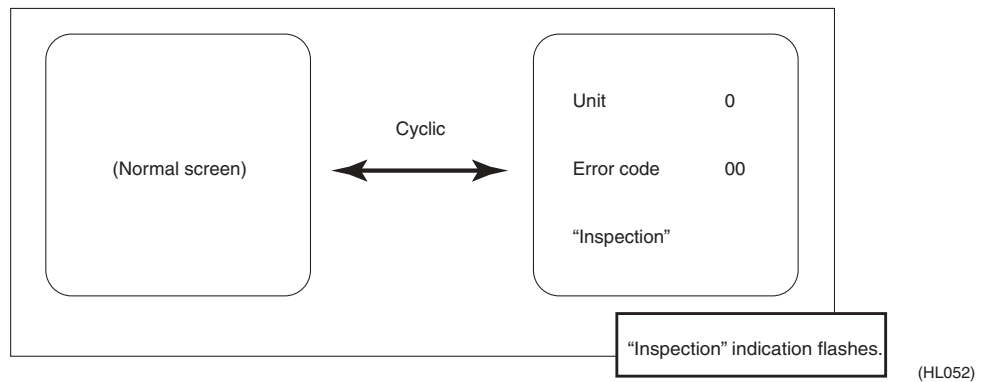

1.1.7 Field Setting

(Example of setting operation)

Centralized control group No. setting (mode No.: 00)

1. Press for more than 4 seconds.
2. Set mode No. to "00" using or .
3. Set centralized control group No. using [▲] or [▼].
4. Enter displayed group No. by pressing .
5. Press to return to normal operation mode.

Centralized control group No. setting (mode No.: 30)

For group control, the following step must be performed.
 (*) Set unit No. using .

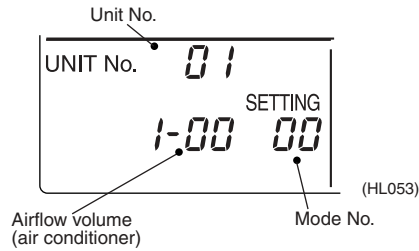

Procedure for entering individual settings (mode No.: 44)

- The setting is generally the same for all units in the same group control system. However, the setting of selected units can be fixed by the following method.

< Example >

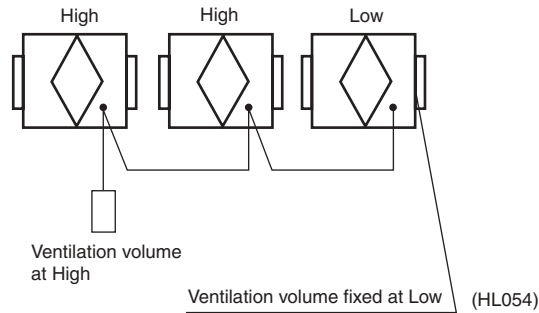

This setting method can be used when a group control system is connected with units having a different airflow capacity from other units in the system.

1. Press for more than 4 seconds.
2. Set mode No. to "44" using or .
3. Set unit No. using .
4. Set airflow volume (ventilation mode) using [▲].
5. Set airflow direction (ventilation volume) using [▼].
6. Enter settings by pressing .

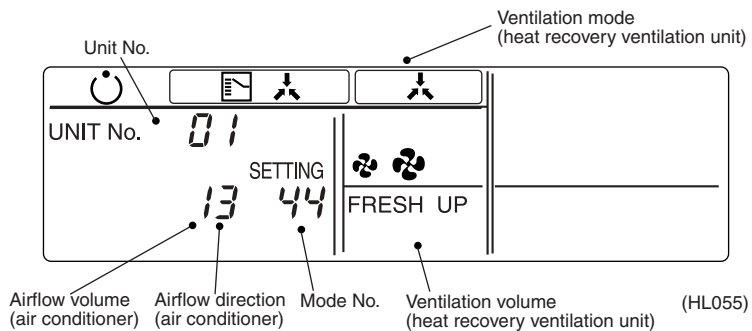

Individual Settings

Heat Recovery Ventilation Unit		Air Conditioner			
Ventilation Volume	Ventilation Mode	Airflow Volume		Airflow Direction	
As indicated by LCD	As indicated by LCD	Low	1	P0	0
				~	~
		High	3	P4	4
				Swing	5

Part 9 Appendix

1. Appendix	66
1.1 Wiring Diagram.....	66

1. Appendix

1.1 Wiring Diagram

VAM150FAVE / VAM250FAVE / VAM350FAVE / VAM500FAVE / VAM650FAVE / VAM800FAVE / VAM1000FAVE

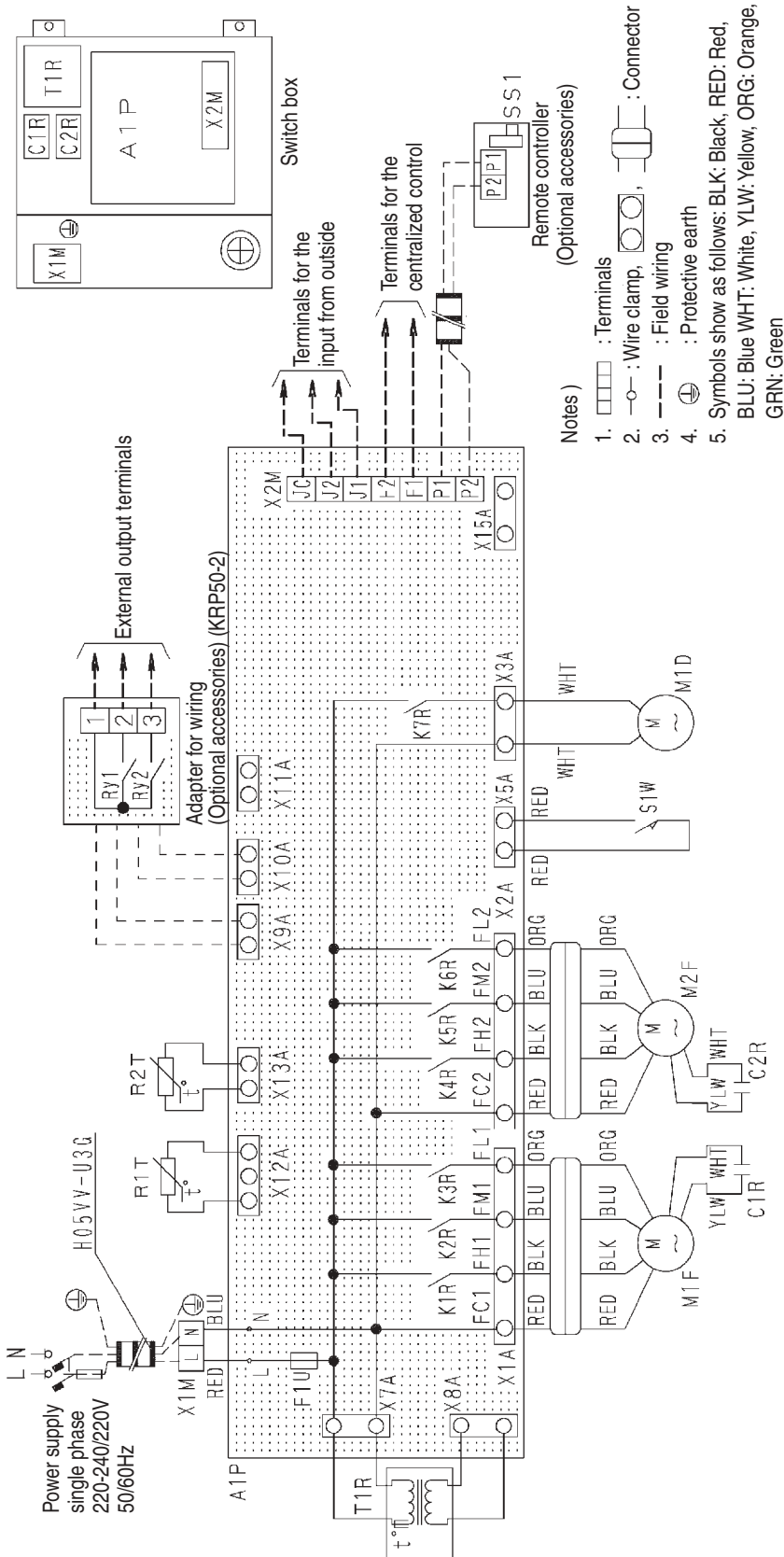

- Notes
- □ □ □ : Terminals
 - : Wire clamp, ○ ○ ○ ○ : Connector
 - - - : Field wiring
 - ⊕ : Protective earth
 - Symbols show as follows: BLK: Black, RED: Red, BLU: Blue, WHT: White, YLW: Yellow, ORG: Orange, GRN: Green

3D036847A

L-RED	N-BLU	Q1M•Q2M	Thermo switch (M1F-2 Built-in)	Optional accessories
A1P	Printed circuit board	R1T	Thermistor (Indoor air)	Adapter for wiring (KRP50-2)
C1R•C2R	Capacitor (M1F-M2F)	R2T	Thermistor (Outdoor air)	Magnetic relay (ON/OFF)
F1U	Fuse (250V, 10A)	S1W	Limit switch	Magnetic relay (Humidifier operation)
K1R~K3R	Magnetic relay (M1F)	T1R	Transformer (Supply 220-240V/22V)	Connector (KRP50-2)
K4R~K6R	Magnetic relay (M2F)	X1M	Terminal (Power supply)	Remote controller
K7R	Magnetic relay (M1D)	X2M	Terminal (Control)	Selector switch (Main/sub)
M1D	Motor (Dampner motor)			Optional connector
M1F	Motor (Air supply fan motor)			Connector (Adaptor power supply)
M2F	Motor (Exhaust fan motor)			Connector

VAM1500FAVE / VAM2000FAVE

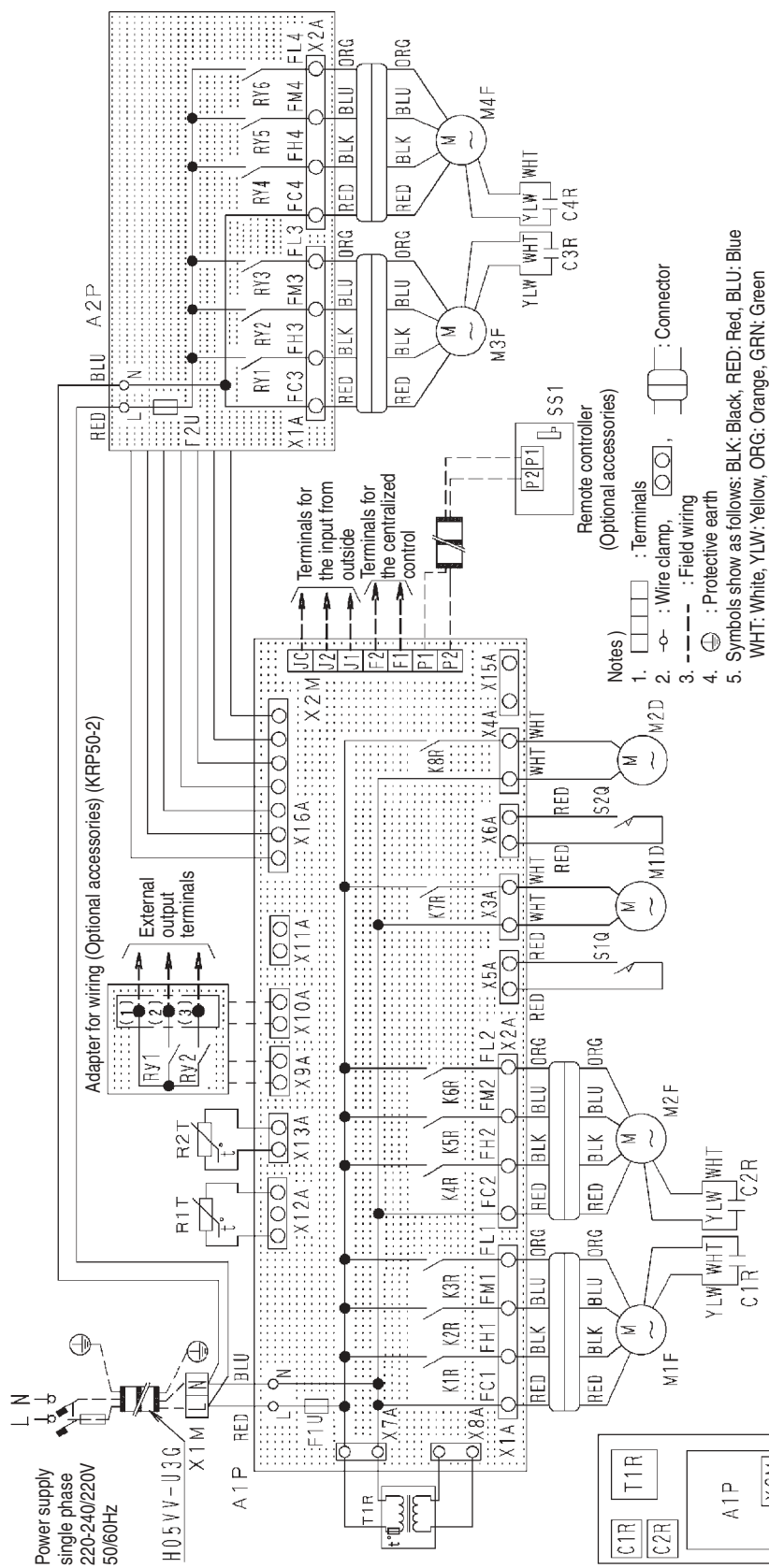

	L-RED	N-BLU	M2F-M4F	Optional accessories
A1P	Printed circuit board (Control)	Q1M-Q4M	Thermo switch (M1F-M4F Built-in)	Adapter for wiring (KRP50-2)
A2P	Printed circuit board (Interface)	RY1-RY3	Magnetic relay (M3F)	Ry1 Magnetic relay (ON/OFF)
C1R-C4R	Capacitor (M1F-M4F)	RY4-RY6	Magnetic relay (M4F)	Ry2 Magnetic relay (Humidifier operation)
F1U-F2U	Fuse (250V, 10A)	R1T	Thermistor (Indoor air)	Remote controller
K1R-K3R	Magnetic relay (M1F)	R2T	Thermistor (Outdoor air)	Selector switch (Main/sub)
K4R-K6R	Magnetic relay (M2F)	S1Q-S2Q	Limit switch	Connector for optional parts
K7R	Magnetic relay (M1D)	T1R	Transformer (220-240V/22V)	Connector (for KRP50-2)
K8R	Magnetic relay (M2D)	X1M	Terminal (Power supply)	X10A Connector (for KRP50-2)
M1D-M2D	Motor (Dampener motor)	X2M	Terminal (Control)	X11A Connector (Adaptor power supply)
M1F-M3F	Motor (Air supply fan motor)			X15A Connector

3D036846A

Index

- A**
- Abnormality control function20
 - Air conditioner link function20
 - Air Conditioner Link Operation23
 - Air conditioner link operation31
 - Air Filter (Long Life Filter)2, 3
 - Air flow setting25
 - Air Supply Fan2, 3
 - Airflow rate setting switch interface31
 - Auto restart setting24
 - Automatic ventilation operation function20
- C**
- Ceiling Hock2, 3
 - Central data transmission interface31
 - Centralized / individual setting24
 - Centralized control function20
 - Centralized control group No. setting59
 - mode No. 0062
 - mode No. 3062
 - Centralized control group No. setting (group)59
 - Centralized control group No. setting
 - (Mode No. 00) Setting of Individual No.
 - (Mode No. 30)55
 - Centralized System10
 - Centralized zone interlock setting24
 - Check microcomputer operation monitor.47
 - Circuit Functions31
 - Circuit Operations30
 - CLEANING FREQUENCY16
 - Cold Area Mode23
 - Combined Operation System with VRV Systems
 - and Skyair Series10
 - Control microcomputer31
- D**
- Damper2, 3
 - Damper limit switch interface31
 - Damper Motor2, 3, 52
 - Damper System Error (Alarm)39, 40
 - Data Transmission Error (Between LCD Master
 - Remote Controller
 - and Slave Remote Controller)44
 - Data Transmission Error (Between LCD
 - Remote Controller and Main Unit)42
 - Data Transmission Error
 - (LCD Remote Controller)43
 - Dedicated LCD Remote Controller41, 48
 - Dedicated Remote Controller41
 - Direct duct connection with air conditioner21
 - Display OFF in automatic ventilation mode60
 - Duct Connection Flange2, 3
- E**
- EEPROM31
 - Electric heater setting25
 - Error Code 6035, 36
 - Error Code 6437
 - Error Code 6538
 - Error Code 6A39, 40
 - Error Code Indication34
 - Error Code U542, 43
 - Error Code U844
 - Error Code UA45
 - Error Code UC46
 - Error record display25, 59
 - Exhaust Air2, 3
 - Exhaust Fan2, 3
 - Explanation for Systems10
 - External Damper Operation
 - Essential Setting Changes26
 - Essential Wiring26
 - Explanation of Functions26
 - External input interface31
 - External input terminal function selection
 - (between J1 and J2)25
 - External link operation function20
 - External signal setting JC / J224
- F**
- Fan motor, damper motor relay31
 - Fan speed initial setting24
 - Field Setting59
 - Field Setting Error45
 - Field setting function20
 - Field Setting, Service Mode24
 - Field Setting, Service Mode Operation54
 - Filter cleaning time setting24
 - Filter sign function20
 - Forced fan ON59
 - Forced ventilation fan On25
 - FRESH UP11
 - Fresh up air supply / exhaust setting25
 - Fresh up operation25
 - Freshup function20
 - Function of main connection terminal27
- G**
- General Constructions2
 - General setting59
 - Group function20
 - Group No. setting for centralized controller
 - (individual)24
- H**
- Heat Exchange Element (X2)17
 - Heat Exchange Element (X4)17
 - Heat Exchange Elements2, 3

How to Check	49	Overall Malfunction	36
HOW TO OPERATE WITH TIMER	12	Overlapping Central Control Address	46
Humidifier operation control function	20		
I		P	
Independent Operation of The HRV Unit Using The Centralized Controller (DCS302B61)	14	Power ON operation function	20
Independent System	10	Power supply circuit	31
Indication of ventilation mode / Not indication	25	Power Transformer	51
Individual setting	59	Power transformer	31
Individual Settings	63	Pre-cool/pre-heat function	20
Indoor Air Thermistor Error	37	Pre-cool/pre-heat On/Off setting	24
Initial setting (mode Nos. 17, 27, 18, 28)	54	Pre-cool/pre-heat operations	22
Inspection operation	61	Pre-cool/pre-heat time (min.) setting	24
		Pre-heat time extension setting	24
K		Printed Circuit Board	27
KRP50-2	20	Procedure for entering individual settings (mode No. 44)	62
KRP50-2 interface	31	Product Specification	6
KRP50-2 output switching selection (between 1 and 3)	25		
L		R	
Layout of switches on Printed Circuit Board	27	Relay drive circuit	31
LCD and Operation Panel	60	Remote control data transmission interface	31
List of Control Functions	20	Remote Controller	2, 3
List of field setting mode Nos.	59	Remote Controller for HRV BRC301B61	11
List of malfunction codes displayed by LCD remote controller	34	Remote Controller for VRV BRC1A51	14
		Remote Controller for VRV BRC1C51-61	13
M		Remote controller function	20
Main Unit PCB	41	Remove thermistor and check resistance with tester	50
Main Unit PCB Assembly	47	Return Air	2, 3
Maintenance Cover	2, 3, 16		
Maintenance for The Air Filter	16	S	
Maintenance for The Heat Exchange Element	18	Sensor data	59
Maintenance Space for The Air Filters, Heat Exchange Elements and Switch Box	2, 3	Service Mode Operation	56
Microcomputer oscillation circuit	31	Setting for cold areas (Fan operation selection for heater thermostat OFF)	24
Microcomputer reset circuit	31	Setting for direct power-on	24
		Setting mode	24
N		Setting switch No.	24
Name Plate	2, 3	Supply Air	2, 3
Normal operation	21	Switch Box	2, 3
Normal ventilation mode	60		
O		T	
Operating The HRV Unit Using The Remote Controller of The VRV-System Air Conditioner	13	Thermistor	50
Operation Changeover Control	58	Thermistor interface	31
Operation chart	21	Thermistor temperature - resistance conversion table	37, 38, 50
Operation for INDIVIDUAL SYSTEM	11	Timer function	20
Operation HRV Units with The Remote Control exclusively for Air Conditioning Operation. (BRC301B61)	11	To clean the air filter	17
Operation mode selector	14	to dry Air filter	17
Outdoor Air	2, 3	Total heat exchange ventilation mode	60
Outdoor Air Thermistor Error	38	Troubleshooting function	20
Overall Alarm	35	Turn on the forced fan (Mode No.43)	56
		U	
		Unit No. allocation	25
		Unit No. reallocation	59
		Unit No. reallocation (Mode No.45)	57
		V	
		Ventilation capacity changeover function	20

Ventilation mode	
Total heat exchange	60
Ventilation mode changeover function	20
Ventilation mode setting	25
Ventilation Operation Control	21
Ventilation operation control function	20
Ventilation volume (Freshup) setting changes	61
W	
When no indication is displayed on remote controller	48
Y	
Yes / No setting for direct duct Connection with VRV system	24

Drawings & Flow Charts

A		VAM2000FAVE	3
Air Conditioner Link Operation		VAM250FAVE	2
1 group link control	23	VAM350FAVE	2
Link control of 2 or more groups	24	VAM500FAVE	2
Air flow rate can be changed over	11	VAM650FAVE	2
		VAM800FAVE	2
C		H	
Centralized control group No. setting	55, 62	HOW TO OPERATE WITH TIMER	12
Check 1	49	I	
Check 2	49	Initial setting (mode Nos. 17, 27, 18, 28)	54
Check 3	49	Inspection operation	61
Check damper motor	52	L	
Check microcomputer operation monitor	47	LCD and Operation Panel	60
Check resistance and voltage	39	M	
Check resistance and voltage -		Main Unit PCB	41
DAMPER MOTOR	52	Main unit PCB	47
Check resistance and voltage with tester	51	Maintenance Cover	
Circuit Configuration	30	VAM150~1000FAVE	16
Cold Area Mode	23	VAM1500~2000FAVE	16
Connect remote controller cable and remote		Maintenance for The Heat Exchange Element	18
controller	42	N	
D		Normal ventilation mode	60
Dedicated Remote Controller	41	O	
Display OFF in automatic ventilation mode	60	Operation Changeover Control	58
dry Air filter	17	Operation for Each System	10
E		operation mode selector	14
Error Code 60	35, 36	P	
Error Code 64	37	Power Transformer	51
Error Code 65	38	Pre-cool/pre-heat operations	22
Error Code 6A	39, 40	Printed Circuit Board	27
Error Code Indication	34	Procedure for entering individual settings	
Error Code U5	42, 43	(mode No. 44)	62
Error Code U8	44	R	
Error Code UA	45	Remote Controller for HRV BRC301B61	11
Error Code UC	46	Remote Controller for VRV BRC1A51	14
Explanation of Individual Functions		Remote Controller for VRV BRC1C51·61	13
Direct duct connection with air conditioner	21	Remove thermistor and check resistance	
Normal operation	21	with tester	50
External Damper Operation		T	
Essential Setting Changes	26	Take out the heat exchange elements	
Essential Wiring	26	VAM150~1000FAVE	17
Explanation of Functions	26	VAM1500~2000FAVE	17
F		To clean the air filter	17
Field Setting	59	Total heat exchange ventilation mode	60
Function of main connection terminal	27	Turn on the forced fan (Mode No.43)	56
G			
General Constructions			
VAM1000FAVE	2		
VAM1500FAVE	3		
VAM150FAVE	2		

U

Unit No. reallocation (Mode No.45)	57
Use tester to check resistance	37, 38

V

Ventilation mode	
Total heat exchange	60
Ventilation mode changeover	12
Ventilation volume (Freshup) setting changes	61

W

When "88" remains on remote controller display ..	41
When no indication is displayed	
on remote controller	48
Wiring Diagram	
VAM1500FAVE / VAM2000FAVE	67
VAM150FAVE / VAM250FAVE /	
VAM350FAVE / VAM500FAVE /	
VAM650FAVE / VAM800FAVE /	
VAM1000FAVE	66



Daikin Europe N.V. is approved by LRQA for its Quality Management System in accordance with the ISO9001 standard. ISO9001 pertains to quality assurance regarding design, development, manufacturing as well as to services related to the product.



Daikin units comply with the European regulations that guarantee the safety of the product.



ISO14001 assures an effective environmental management system in order to help protect human health and the environment from the potential impact of our activities, products and services and to assist in maintaining and improving the quality of the environment.

VRV products are not within the scope of the Eurovent certification programme.

Specifications are subject to change without prior notice



DAIKIN EUROPE N.V.

Zandvoordestraat 300

B-8400 Ostend - Belgium

Internet: <http://www.daikineurope.com>