

Service Manual

Inverter Pair Wall Mounted Type C-Series



[Applied Models]

- Inverter Pair : Cooling Only
- Inverter Pair : Heat Pump

Inverter Pair C-Series

●Cooling Only

Indoor Unit

FTKS20CVMB(9)	ATKS20CVMB(9)	FTN20CVMB9
FTKS25CVMB(9)(8)	ATKS25CVMB(9)	FTN25CVMB9
FTKS35CVMB(9)(8)	ATKS35CVMB(9)	FTN35CVMB9

Outdoor Unit

RKS20CVMB	ARKS20CVMB	
RKS25CVMB	ARKS25CVMB	
RKS35CVMB	ARKS35CVMB	
RKH20CVMB9	ARKH20CVMB9	RN20CVMB9
RKH25CVMB9	ARKH25CVMB9	RN25CVMB9
RKH35CVMB9	ARKH35CVMB9	RN35CVMB9

●Heat Pump

Indoor Unit

FTXS20CVMB(9)	ATXS20CVMB(9)	FTYN20CVMB9
FTXS25CVMB(9)(8)	ATXS25CVMB(9)	FTYN25CVMB9
FTXS35CVMB(9)(8)	ATXS35CVMB(9)	FTYN35CVMB9

Outdoor Unit

RXS20CVMB	ARXS20CVMB	
RXS25CVMB	ARXS25CVMB	
RXS35CVMB	ARXS35CVMB	
RXH20CVMB9	ARXH20CVMB9	RYN20CVMB9
RXH25CVMB9	ARXH25CVMB9	RYN25CVMB9
RXH35CVMB9	ARXH35CVMB9	RYN35CVMB9

1. Introduction	V
1.1 Safety Cautions	V
Part 1 List of Functions	1
1. List of Functions	2
1.1 High Grade Models	2
1.2 Standard Grade Models	4
1.3 Non-Inverter Models	6
Part 2 Specifications	7
1. Specifications	8
1.1 Cooling Only	8
1.2 Heat Pump	13
Part 3 Printed Circuit Board Connector Wiring Diagram	23
1. Printed Circuit Board Connector Wiring Diagram	24
1.1 Indoor Unit	24
1.2 Outdoor Unit / RK(X)S-C, ARK(X)S-C	26
1.3 Outdoor Unit / RK(X)H-C, ARK(X)H-C, R(Y)N-C	28
Part 4 Function and Control	29
1. Main Functions	30
1.1 Frequency Principle	30
1.2 Power-Airflow Dual Flaps, Wide-Angle Louvres and Auto-Swing	32
1.3 Fan Speed Control for Indoor Units	33
1.4 Programme Dry Function	34
1.5 Automatic Operation	35
1.6 NIGHT SET Mode	36
1.7 INTELLIGENT EYE	37
1.8 HOME LEAVE Operation	39
1.9 Inverter Powerful Operation	40
1.10 Other Functions	41
2. Function of Main Structural Parts	42
2.1 Function of Thermistor	42
3. Control Specification	44
3.1 Mode Hierarchy	44
3.2 Frequency Control	45
3.3 Controls at Mode Changing / Start-up	47
3.4 Discharge Pipe Control	48
3.5 Input Current Control	49
3.6 Freeze-up Protection Control	49
3.7 Heating Peak-cut Control	50
3.8 Fan Control	50
3.9 Liquid Compression Protection Function 2	50
3.10 Defrost Control	51
3.11 Electronic Expansion Valve Control	52
3.12 Malfunctions	55
3.13 Forced Operation Mode	56
3.14 Additional Function	56

3.15 Facility Setting Jumper (cooling at low outdoor temperature)	57
-------------------------------------------------------------------------	----

Part 5 System Configuration..... 59

1. System Configuration.....	60
2. Instruction.....	61
2.1 Safety precautions.....	61
2.2 Names of parts	63
2.3 Preparation before Operation	66
2.4 AUTO · DRY · COOL · HEAT · FAN Operation	69
2.5 Adjusting the Air Flow Direction	71
2.6 POWERFUL Operation	73
2.7 OUTDOOR UNIT SILENT Operation	74
2.8 HOME LEAVE Operation	75
2.9 INTELLIGENT EYE Operation	77
2.10 TIMER Operation	79
2.11 Care and Cleaning	81
2.12 Troubleshooting.....	84

Part 6 Service Diagnosis..... 89





1. Caution for Diagnosis.....	90
2. Problem Symptoms and Measures	91
3. Service Check Function	92
4. Troubleshooting	95
4.1 Error Codes and Description	95
4.2 Indoor Unit PCB Abnormality	96
4.3 Freeze-up Protection Control or High Pressure Control.....	97
4.4 Fan Motor (AC Motor) or Related Abnormality	99
4.5 Thermistor or Related Abnormality (Indoor Unit).....	100
4.6 Signal Transmission Error (between Indoor and Outdoor Unit)	101
4.7 OL Activation (Compressor Overload)	102
4.8 Compressor Lock	103
4.9 DC Fan Lock	104
4.10 Input Over Current Detection	105
4.11 Four Way Valve Abnormality	106
4.12 Discharge Pipe Temperature Control.....	108
4.13 High Pressure Control in Cooling	109
4.14 Position Sensor Abnormality	111
4.15 DC Voltage / Current Sensor Abnormality.....	112
4.16 Thermistor or Related Abnormality (Outdoor Unit).....	113
4.17 Electrical Box Temperature Rise.....	115
4.18 Radiation Fin Temperature Rise	117
4.19 Output Over Current Detection.....	119
4.20 Insufficient Gas.....	121
4.21 Over-voltage Detection.....	123
5. Check	124
5.1 How to Check.....	124

Part 7 Removal Procedure	133
1. Indoor Unit.....	134
1.1 Removal of Air Filter.....	134
1.2 Removal of Front Grille	137
1.3 Removal of Horizontal Blade and Vertical Blade.....	140
1.4 Removal of Electrical Box, PCB and Swing Motor	142
1.5 Removal of Heat Exchanger	148
1.6 Install of Drain Plug	151
1.7 Removal of Fan Rotor and Fan Motor.....	152
2. Outdoor Unit / RK(X)S-C, ARK(X)S-C	156
2.1 Removal of Panels and Fan Motor.....	156
2.2 Removal of Electrical Box	163
2.3 Removal of Reactor and Partition Plate	165
2.4 Removal of Sound Blanket.....	167
2.5 Removal of Four Way Valve.....	169
2.6 Removal of Compressor.....	171
2.7 Removal of PCB.....	173
3. Outdoor Unit / RK(X)H-C, ARK(X)H-C, R(Y)N-C	176
3.1 Removal of External Panels	176
3.2 Removal of Bell mouth	179
3.3 Removal of PCB and Electrical Box	180
3.4 Removal of Propeller Fan and Fan Motor	187
3.5 Removal of Partition Plate and Reactor	190
3.6 Removal of Sound Insulation Pad	193
3.7 Removal of Electronic Expansion Valve and Four Way Valve	196
3.8 Removal of Compressor.....	200
Part 8 Others	203
1. Others	204
1.1 Test Run from the Remote Controller	204
1.2 Jumper Settings	205
Part 9 Appendix.....	207
1. Piping Diagrams.....	208
1.1 Indoor Units	208
1.2 Outdoor Units	209
2. Wiring Diagrams.....	213
2.1 Indoor Units	213
2.2 Outdoor Units	214
Index	i
Drawings & Flow Charts	v







1. Introduction







1.1 Safety Cautions

Cautions and Warnings

- Be sure to read the following safety cautions before conducting repair work.
- The caution items are classified into “ **Warning**” and “ **Caution**”. The “ **Warning**” items are especially important since they can lead to death or serious injury if they are not followed closely. The “ **Caution**” items can also lead to serious accidents under some conditions if they are not followed. Therefore, be sure to observe all the safety caution items described below.
- About the pictograms
 - △ This symbol indicates an item for which caution must be exercised.
The pictogram shows the item to which attention must be paid.
 - This symbol indicates a prohibited action.
The prohibited item or action is shown inside or near the symbol.
 - This symbol indicates an action that must be taken, or an instruction.
The instruction is shown inside or near the symbol.
- After the repair work is complete, be sure to conduct a test operation to ensure that the equipment operates normally, and explain the cautions for operating the product to the customer.



1.1.1 Caution in Repair



 Warning	
<p>Be sure to disconnect the power cable plug from the plug socket before disassembling the equipment for a repair. Working on the equipment that is connected to a power supply can cause an electrical shock. If it is necessary to supply power to the equipment to conduct the repair or inspecting the circuits, do not touch any electrically charged sections of the equipment.</p>	
<p>If the refrigerant gas discharges during the repair work, do not touch the discharging refrigerant gas. The refrigerant gas can cause frostbite.</p>	
<p>When disconnecting the suction or discharge pipe of the compressor at the welded section, release the refrigerant gas completely at a well-ventilated place first. If there is a gas remaining inside the compressor, the refrigerant gas or refrigerating machine oil discharges when the pipe is disconnected, and it can cause injury.</p>	
<p>If the refrigerant gas leaks during the repair work, ventilate the area. The refrigerant gas can generate toxic gases when it contacts flames.</p>	
<p>The step-up capacitor supplies high-voltage electricity to the electrical components of the outdoor unit. Be sure to discharge the capacitor completely before conducting repair work. A charged capacitor can cause an electrical shock.</p>	
<p>Do not start or stop the air conditioner operation by plugging or unplugging the power cable plug. Plugging or unplugging the power cable plug to operate the equipment can cause an electrical shock or fire.</p>	

 Warning	
Do not repair the electrical components with wet hands. Working on the equipment with wet hands can cause an electrical shock.	
Do not clean the air conditioner by splashing water. Washing the unit with water can cause an electrical shock.	
Be sure to provide the grounding when repairing the equipment in a humid or wet place, to avoid electrical shocks.	
Be sure to turn off the power switch and unplug the power cable when cleaning the equipment. The internal fan rotates at a high speed, and cause injury.	
Do not tilt the unit when removing it. The water inside the unit can spill and wet the furniture and floor.	
Be sure to check that the refrigerating cycle section has cooled down sufficiently before conducting repair work. Working on the unit when the refrigerating cycle section is hot can cause burns.	
Use the welder in a well-ventilated place. Using the welder in an enclosed room can cause oxygen deficiency.	



1.1.2 Cautions Regarding Products after Repair



 Warning	
Be sure to use parts listed in the service parts list of the applicable model and appropriate tools to conduct repair work. Never attempt to modify the equipment. The use of inappropriate parts or tools can cause an electrical shock, excessive heat generation or fire.	
When relocating the equipment, make sure that the new installation site has sufficient strength to withstand the weight of the equipment. If the installation site does not have sufficient strength and if the installation work is not conducted securely, the equipment can fall and cause injury.	
Be sure to install the product correctly by using the provided standard installation frame. Incorrect use of the installation frame and improper installation can cause the equipment to fall, resulting in injury.	For integral units only
Be sure to install the product securely in the installation frame mounted on a window frame. If the unit is not securely mounted, it can fall and cause injury.	For integral units only
Be sure to use an exclusive power circuit for the equipment, and follow the technical standards related to the electrical equipment, the internal wiring regulations and the instruction manual for installation when conducting electrical work. Insufficient power circuit capacity and improper electrical work can cause an electrical shock or fire.	



 Warning	
Be sure to use the specified cable to connect between the indoor and outdoor units. Make the connections securely and route the cable properly so that there is no force pulling the cable at the connection terminals. Improper connections can cause excessive heat generation or fire.	
When connecting the cable between the indoor and outdoor units, make sure that the terminal cover does not lift off or dismount because of the cable. If the cover is not mounted properly, the terminal connection section can cause an electrical shock, excessive heat generation or fire.	
Do not damage or modify the power cable. Damaged or modified power cable can cause an electrical shock or fire. Placing heavy items on the power cable, and heating or pulling the power cable can damage the cable.	
Do not mix air or gas other than the specified refrigerant (R410A / R22) in the refrigerant system. If air enters the refrigerating system, an excessively high pressure results, causing equipment damage and injury.	
If the refrigerant gas leaks, be sure to locate the leak and repair it before charging the refrigerant. After charging refrigerant, make sure that there is no refrigerant leak. If the leak cannot be located and the repair work must be stopped, be sure to perform pump-down and close the service valve, to prevent the refrigerant gas from leaking into the room. The refrigerant gas itself is harmless, but it can generate toxic gases when it contacts flames, such as fan and other heaters, stoves and ranges.	
When replacing the coin battery in the remote controller, be sure to disposed of the old battery to prevent children from swallowing it. If a child swallows the coin battery, see a doctor immediately.	

 Caution	
Installation of a leakage breaker is necessary in some cases depending on the conditions of the installation site, to prevent electrical shocks.	
Do not install the equipment in a place where there is a possibility of combustible gas leaks. If a combustible gas leaks and remains around the unit, it can cause a fire.	
Be sure to install the packing and seal on the installation frame properly. If the packing and seal are not installed properly, water can enter the room and wet the furniture and floor.	For integral units only

1.1.3 Inspection after Repair

 Warning	
Check to make sure that the power cable plug is not dirty or loose, then insert the plug into a power outlet all the way. If the plug has dust or loose connection, it can cause an electrical shock or fire.	
If the power cable and lead wires have scratches or deteriorated, be sure to replace them. Damaged cable and wires can cause an electrical shock, excessive heat generation or fire.	





 Warning	
Do not use a joined power cable or extension cable, or share the same power outlet with other electrical appliances, since it can cause an electrical shock, excessive heat generation or fire.	

 Caution	
Check to see if the parts and wires are mounted and connected properly, and if the connections at the soldered or crimped terminals are secure. Improper installation and connections can cause excessive heat generation, fire or an electrical shock.	
If the installation platform or frame has corroded, replace it. Corroded installation platform or frame can cause the unit to fall, resulting in injury.	
Check the grounding, and repair it if the equipment is not properly grounded. Improper grounding can cause an electrical shock.	
Be sure to measure the insulation resistance after the repair, and make sure that the resistance is 1 Mohm or higher. Faulty insulation can cause an electrical shock.	
Be sure to check the drainage of the indoor unit after the repair. Faulty drainage can cause the water to enter the room and wet the furniture and floor.	

1.1.4 Using Icons

Icons are used to attract the attention of the reader to specific information. The meaning of each icon is described in the table below:

1.1.5 Using Icons List

Icon	Type of Information	Description
 Note:	Note	A “note” provides information that is not indispensable, but may nevertheless be valuable to the reader, such as tips and tricks.
 Caution	Caution	A “caution” is used when there is danger that the reader, through incorrect manipulation, may damage equipment, lose data, get an unexpected result or has to restart (part of) a procedure.
 Warning	Warning	A “warning” is used when there is danger of personal injury.
	Reference	A “reference” guides the reader to other places in this binder or in this manual, where he/she will find additional information on a specific topic.

Part 1

List of Functions

1. List of Functions	2
1.1 High Grade Models	2
1.2 Standard Grade Models	4
1.3 Non-Inverter Models	6

1. List of Functions

1.1 High Grade Models

Category	Functions	FTKS20-35CVMB(9)(8) RKS20-35CVMB		Category	Functions	FTKS20-35CVMB(9)(8) RKS20-35CVMB	
		FTXS20-35CVMB(9)(8) RXS20-35CVMB	FTXS20-35CVMB(9)(8) RXS20-35CVMB			FTXS20-35CVMB(9)(8) RXS20-35CVMB	FTXS20-35CVMB(9)(8) RXS20-35CVMB
Basic Function	Inverter (with Inverter Power Control)	○	○	Health & Clean	Air Purifying Filter with Bacteriostatic, Virustatic Functions	—	—
	Operation Limit for Cooling (°CDB) ★1	-10 ~46	-10 ~46		Photocatalytic Deodorizing Filter	—	—
	Operation Limit for Heating (°CWB)	—	-15 ~20		Air Purifying Filter with Photocatalytic Deodorizing Function	○	○
	PAM Control	○	○		Titanium Apatite Photocatalytic Air-Purifying Filter	—	—
Compressor	Oval Scroll Compressor	—	—	Health & Clean	Mold Proof Air Filter	○	○
	Swing Compressor	○	○		Wipe-clean Flat Panel	○	○
	Rotary Compressor	—	—		Washable Grille	—	—
	Reluctance DC Motor	○	○		Filter Cleaning Indicator	—	—
Comfortable Airflow	Power-Airflow Flap	—	—	Timer	Good-Sleep Cooling Operation	—	—
	Power-Airflow Dual Flaps	○	○		24-Hour On/Off Timer	○	○
	Power-Airflow Diffuser	—	—		Night Set Mode	○	○
	Wide-Angle Louvers	○	○	Worry Free "Reliability & Durability"	Auto-Restart (after Power Failure)	○	○
	Vertical Auto-Swing (Up and Down)	○	○		Self-Diagnosis (Digital, LED) Display	○ ★2	○ ★2
	Horizontal Auto-Swing (Right and Left)	—	—		Wiring Error Check	—	—
	3-D Airflow	—	—		Anticorrosion Treatment of Outdoor Heat Exchanger	○	○
Comfort Airflow Mode	—	—	Flexibility	Multi-Split / Split Type Compatible Indoor Unit	○	○	
3-Step Airflow (H/P Only)	—	—		Flexible Voltage Correspondence	○	○	
Comfort Control	Auto Fan Speed	○		○	High Ceiling Application	—	—
	Indoor Unit Silent Operation	○		○	Chargeless	10m	10m
	Night Quiet Mode (Automatic)	—		—	Either Side Drain (Right or Left)	○	○
	Outdoor Unit Silent Operation (Manual)	○		○	Power Selection	—	—
	Intelligent Eye	○		○	Remote Control	5-Rooms Centralized Controller (Option)	○
	Quick Warming Function	—	○	Remote Control Adaptor (Normal Open-Pulse Contact)(Option)		○	○
	Hot-Start Function	—	○	Remote Control Adaptor (Normal Open Contact)(Option)		○	○
Automatic Defrosting	—	○	DIII-NET Compatible (Adaptor)(Option)	○		○	
Operation	Automatic Operation	—	○	Remote Controller	Wireless	○	○
	Programme Dry Function	○	○		Wired	—	—
	Fan Only	○	○				
Lifestyle Convenience	New Powerful Operation (Non-Inverter)	—	—				
	Inverter Powerful Operation	○	○				
	Priority-Room Setting	—	—				
	Cooling / Heating Mode Lock	—	—				
	Home Leave Operation	○	○				
	Indoor Unit On/Off Switch	○	○				
	Signal Reception Indicator	○	○				
	Temperature Display	—	—				
Another Room Operation	—	—					

Note: ○ : Holding Functions
— : No Functions

★1 : Lower limit can be extended to -15°C by cutting jumper. (facility use only)
★2 : Digital Only

Category	Functions	ATKS20-35CVMB(9) ARKS20-35CVMB	ATXS20-35CVMB(9) ARXS20-35CVMB	Category	Functions	ATKS20-35CVMB(9) ARKS20-35CVMB	ATXS20-35CVMB(9) ARXS20-35CVMB	
Basic Function	Inverter (with Inverter Power Control)	○	○	Health & Clean	Air Purifying Filter with Bacteriostatic, Virustatic Functions	—	—	
	Operation Limit for Cooling (°CDB) ★1	-10 ~46	-10 ~46		Photocatalytic Deodorizing Filter	—	—	
	Operation Limit for Heating (°CWB)	—	-15 ~20		Air Purifying Filter with Photocatalytic Deodorizing Function	○	○	
	PAM Control	○	○		Titanium Apatite Photocatalytic Air-Purifying Filter	—	—	
Compressor	Oval Scroll Compressor	—	—	Timer	Mold Proof Air Filter	○	○	
	Swing Compressor	○	○		Wipe-clean Flat Panel	—	—	
	Rotary Compressor	—	—		Washable Grille	○	○	
	Reluctance DC Motor	○	○		Filter Cleaning Indicator	—	—	
Comfortable Airflow	Power-Airflow Flap	—	—	Worry Free "Reliability & Durability"	Good-Sleep Cooling Operation	—	—	
	Power-Airflow Dual Flaps	○	○		24-Hour On/Off Timer	○	○	
	Power-Airflow Diffuser	—	—		Night Set Mode	○	○	
	Wide-Angle Louvers	○	○		Auto-Restart (after Power Failure)	○	○	
	Vertical Auto-Swing (Up and Down)	○	○		Self-Diagnosis (Digital, LED) Display	★2	★2	
	Horizontal Auto-Swing (Right and Left)	—	—		Wiring Error Check	—	—	
	3-D Airflow	—	—		Anticorrosion Treatment of Outdoor Heat Exchanger	○	○	
	Comfort Airflow Mode	—	—		Flexibility	Multi-Split / Split Type Compatible Indoor Unit	○	○
3-Step Airflow (H/P Only)	—	—	Flexible Voltage Correspondence	○		○		
Comfort Control	Auto Fan Speed	○	○	High Ceiling Application		—	—	
	Indoor Unit Silent Operation	○	○	Chargeless		10m	10m	
	Night Quiet Mode (Automatic)	—	—	Either Side Drain (Right or Left)		○	○	
	Outdoor Unit Silent Operation (Manual)	○	○	Power Selection		—	—	
	Intelligent Eye	○	○	Remote Control		5-Rooms Centralized Controller (Option)	○	○
	Quick Warming Function	—	○			Remote Control Adaptor (Normal Open-Pulse Contact)(Option)	○	○
	Hot-Start Function	—	○		Remote Control Adaptor (Normal Open Contact)(Option)	○	○	
	Automatic Defrosting	—	○		DIII-NET Compatible (Adaptor)(Option)	○	○	
Operation	Automatic Operation	—	○	Remote Controller	Wireless	○	○	
	Programme Dry Function	○	○		Wired	—	—	
	Fan Only	○	○					
Lifestyle Convenience	New Powerful Operation (Non-Inverter)	—	—					
	Inverter Powerful Operation	○	○					
	Priority-Room Setting	—	—					
	Cooling / Heating Mode Lock	—	—					
	Home Leave Operation	○	○					
	Indoor Unit On/Off Switch	○	○					
	Signal Reception Indicator	○	○					
	Temperature Display	—	—					
Another Room Operation	—	—						

Note: ○ : Holding Functions
— : No Functions

★1 : Lower limit can be extended to -15°C by cutting jumper. (facility use only)
★2 : Digital Only

1.2 Standard Grade Models

Category	Functions	FTKS20-35CVMB(9)(8) RKH20-35CVMB9	FTXS20-35CVMB(9)(8) RXH20-35CVMB9	Category	Functions	FTKS20-35CVMB(9)(8) RKH20-35CVMB9	FTXS20-35CVMB(9)(8) RXH20-35CVMB9	
Basic Function	Inverter (with Inverter Power Control)	○	○	Health & Clean	Air Purifying Filter with Bacteriostatic, Virustatic Functions	—	—	
	Operation Limit for Cooling (°CDB)	10 ~46	10 ~46		Air Purifying Filter with Photocatalytic Deodorizing Function	○	○	
	Operation Limit for Heating (°CWB)	—	-10 ~15		Photocatalytic Deodorizing Filter	—	—	
	PAM Control	—	—		Titanium Apatite Photocatalytic Air-Purifying Filter	—	—	
Compressor	Oval Scroll Compressor	—	—		Mold Proof Air Filter	○	○	
	Swing Compressor	○	○		Wipe-clean Flat Panel	○	○	
	Rotary Compressor	—	—		Washable Grille	—	—	
	Reluctance DC Motor	—	—		Filter Cleaning Indicator	—	—	
Comfortable Airflow	Power-Airflow Flap	—	—		Good-Sleep Cooling Operation	—	—	
	Power-Airflow Dual Flaps	○	○		24-Hour On/Off Timer	○	○	
	Power-Airflow Diffuser	—	—		Night Set Mode	○	○	
	Wide-Angle Louvers	○	○		Timer	Auto-Restart (after Power Failure)	○	○
	Vertical Auto-Swing (Up and Down)	○	○			Self-Diagnosis (Digital, LED) Display	○ ★1	○ ★1
	Horizontal Auto-Swing (Right and Left)	—	—			Wiring Error Check	—	—
	3-D Airflow	—	—			Anticorrosion Treatment of Outdoor Heat Exchanger	○	○
	Comfort Airflow Mode	—	—		Worry Free "Reliability & Durability"	Multi-Split / Split Type Compatible Indoor Unit	○	○
3-Step Airflow (H/P Only)	—	—	Flexible Voltage Correspondence	○		○		
Comfort Control	Auto Fan Speed	○	○	High Ceiling Application		—	—	
	Indoor Unit Silent Operation	○	○	Chargeless		10m	10m	
	Night Quiet Mode (Automatic)	—	—	Either Side Drain (Right or Left)		○	○	
	Outdoor Unit Silent Operation (Manual)	★2	★2	Power Selection		—	—	
	Intelligent Eye	○	○	Flexibility		5-Rooms Centralized Controller (Option)	○	○
	Quick Warming Function	—	○			Remote Control Adaptor (Normal Open-Pulse Contact)(Option)	○	○
	Hot-Start Function	—	○		Remote Control Adaptor (Normal Open Contact)(Option)	○	○	
	Automatic Defrosting	—	○		DIII-NET Compatible (Adaptor)(Option)	○	○	
Operation	Automatic Operation	—	○		Remote Control	Wireless	○	○
	Programme Dry Function	○	○			Wired	—	—
	Fan Only	○	○					
Lifestyle Convenience	New Powerful Operation (Non-Inverter)	—	—		Remote Controller			
	Inverter Powerful Operation	○	○					
	Priority-Room Setting	—	—					
	Cooling / Heating Mode Lock	—	—					
	Home Leave Operation	○	○					
	Indoor Unit On/Off Switch	○	○					
	Signal Reception Indicator	○	○					
	Temperature Display	—	—					
Another Room Operation	—	—						

Note: ○ : Holding Functions
— : No Functions

★1 : Digital Only
★2 : The button on the remote controller does not work.

Category	Functions	ATKS20-35CVMB(9) ARKH20-35CVMB9	ATXS20-35CVMB(9) ARXH20-35CVMB9	Category	Functions	ATKS20-35CVMB(9) ARKH20-35CVMB9	ATXS20-35CVMB(9) ARXH20-35CVMB9	
Basic Function	Inverter (with Inverter Power Control)	○	○	Health & Clean	Air Purifying Filter with Bacteriostatic, Virustatic Functions	—	—	
	Operation Limit for Cooling (°CDB)	10 ~46	10 ~46		Photocatalytic Deodorizing Filter	—	—	
	Operation Limit for Heating (°CWB)	—	-10 ~15		Air Purifying Filter with Photocatalytic Deodorizing Function	○	○	
	PAM Control	—	—		Titanium Apatite Photocatalytic Air-Purifying Filter	—	—	
Compressor	Oval Scroll Compressor	—	—		Mold Proof Air Filter	○	○	
	Swing Compressor	○	○		Wipe-clean Flat Panel	—	—	
	Rotary Compressor	—	—		Washable Grille	○	○	
	Reluctance DC Motor	—	—		Filter Cleaning Indicator	—	—	
Comfortable Airflow	Power-Airflow Flap	—	—		Good-Sleep Cooling Operation	—	—	
	Power-Airflow Dual Flaps	○	○		Timer	24-Hour On/Off Timer	○	○
	Power-Airflow Diffuser	—	—			Night Set Mode	○	○
	Wide-Angle Louvers	○	○		Worry Free "Reliability & Durability"	Auto-Restart (after Power Failure)	○	○
	Vertical Auto-Swing (Up and Down)	○	○	Self-Diagnosis (Digital, LED) Display		★1	★1	
	Horizontal Auto-Swing (Right and Left)	—	—	Wiring Error Check		—	—	
	3-D Airflow	—	—	Anticorrosion Treatment of Outdoor Heat Exchanger		○	○	
	Comfort Airflow Mode	—	—	Flexibility	Multi-Split / Split Type Compatible Indoor Unit	○	○	
3-Step Airflow (H/P Only)	—	—	Flexible Voltage Correspondence		○	○		
Comfort Control	Auto Fan Speed	○	○		High Ceiling Application	—	—	
	Indoor Unit Silent Operation	○	○		Chargeless	10m	10m	
	Night Quiet Mode (Automatic)	—	—		Either Side Drain (Right or Left)	○	○	
	Outdoor Unit Silent Operation (Manual)	★2	★2		Power Selection	—	—	
	Intelligent Eye	○	○		Operation	5-Rooms Centralized Controller (Option)	○	○
	Quick Warming Function	—	○			Remote Control Adaptor (Normal Open-Pulse Contact)(Option)	○	○
	Hot-Start Function	—	○	Remote Control Adaptor (Normal Open Contact)(Option)		○	○	
Operation	Automatic Defrosting	—	○	Remote Control	DIII-NET Compatible (Adaptor)(Option)	○	○	
	Automatic Operation	—	○		Remote Controller	Wireless	○	○
	Programme Dry Function	○	○			Wired	—	—
	Lifestyle Convenience	Fan Only	○	○				
		New Powerful Operation (Non-Inverter)	—	—				
		Inverter Powerful Operation	○	○				
		Priority-Room Setting	—	—				
		Cooling / Heating Mode Lock	—	—				
		Home Leave Operation	○	○				
Indoor Unit On/Off Switch		○	○					
Signal Reception Indicator		○	○					
Temperature Display	—	—						
Another Room Operation	—	—						

Note: ○ : Holding Functions
— : No Functions

★1 : Digital Only
★2 : The button on the remote controller does not work.

1.3 Non-Inverter Models

Category	Functions	FTN20-35CVMB9 RN20-35CVMB9		Category	Functions	FTN20-35CVMB9 RN25-35CVMB9	
		FTN20-35CVMB9 RN20-35CVMB9	FTYN20-35CVMB9 RYN20-35CVMB9			FTN20-35CVMB9 RN25-35CVMB9	FTYN20-35CVMB9 RYN20-35CVMB9
Basic Function	Inverter (with Inverter Power Control)	—	—	Health & Clean	Air Purifying Filter with Bacteriostatic, Virustatic Functions	—	—
	Operation Limit for Cooling (°CDB)	10 ~46	10 ~46		Photocatalytic Deodorizing Filter	—	—
	Operation Limit for Heating (°CWB)	—	-10 ~15		Air Purifying Filter with Photocatalytic Deodorizing Function	○	○
	PAM Control	—	—		Titanium Apatite Photocatalytic Air-Purifying Filter	—	—
Compressor	Oval Scroll Compressor	—	—		Mold Proof Air Filter	○	○
	Swing Compressor	○	○		Wipe-clean Flat Panel	—	—
	Rotary Compressor	—	—		Washable Grille	○	○
	Reluctance DC Motor	—	—		Filter Cleaning Indicator	—	—
Comfortable Airflow	Power-Airflow Flap	—	—		Good-Sleep Cooling Operation	—	—
	Power-Airflow Dual Flaps	○	○		Timer	24-Hour On/Off Timer	○
	Power-Airflow Diffuser	—	—	Night Set Mode		○	○
	Wide-Angle Louvers	○	○	Worry Free "Reliability & Durability"	Auto-Restart (after Power Failure)	○	○
	Vertical Auto-Swing (Up and Down)	○	○		Self-Diagnosis (Digital, LED) Display	○ ★	○ ★
	Horizontal Auto-Swing (Right and Left)	—	—		Wiring Error Check	—	—
	3-D Airflow	—	—		Anticorrosion Treatment of Outdoor Heat Exchanger	○	○
	Comfort Airflow Mode	—	—		Flexibility	Multi-Split / Split Type Compatible Indoor Unit	—
3-Step Airflow (H/P Only)	—	—	Flexible Voltage Correspondence	○		○	
Comfort Control	Auto Fan Speed	○	○	High Ceiling Application		—	—
	Indoor Unit Silent Operation	—	—	Chargeless		10m	10m
	Night Quiet Mode (Automatic)	—	—	Either Side Drain (Right or Left)		○	○
	Outdoor Unit Silent Operation (Manual)	—	—	Power Selection		—	—
	Intelligent Eye	—	—	Remote Control	5-Rooms Centralized Controller (Option)	○	○
	Quick Warming Function	—	○		Remote Control Adaptor (Normal Open-Pulse Contact)(Option)	○	○
	Hot-Start Function	—	○		Remote Control Adaptor (Normal Open Contact)(Option)	○	○
Operation	Automatic Defrosting	—	○	Remote Controller	DIII-NET Compatible (Adaptor)(Option)	—	—
	Automatic Operation	—	○		Wireless	○	○
	Programme Dry Function	○	○		Wired	—	—
Lifestyle Convenience	Fan Only	○	○	Remote Controller			
	New Powerful Operation (Non-Inverter)	○	○				
	Inverter Powerful Operation	—	—				
	Priority-Room Setting	—	—				
	Cooling / Heating Mode Lock	—	—				
	Home Leave Operation	—	—				
	Indoor Unit On/Off Switch	○	○				
	Signal Reception Indicator	○	○				
Temperature Display	—	—					
Another Room Operation	—	—					

Note: ○ : Holding Functions

★ : Digital Only

— : No Functions

Part 2

Specifications

1. Specifications	8
1.1 Cooling Only	8
1.2 Heat Pump	13

1. Specifications

1.1 Cooling Only

1.1.1 High Grade Models

230V, 50Hz

Models	Indoor Units		FTKS20CVMB(9)	FTKS25CVMB(9)(8)	FTKS35CVMB(9)(8)
	Outdoor Units		RKS20CVMB	RKS25CVMB	RKS35CVMB
Capacity Rated (Min.~Max.)		kW	2.0 (1.3~3.0)	2.5 (1.3~3.0)	3.4 (1.4~3.8)
		Btu/h	6,800 (4,450~10,250)	8,550 (4,450~10,250)	11,600 (4,750~12,950)
		kcal/h	1,720 (1,120~2,580)	2,150 (1,120~2,580)	2,920 (1,200~3,270)
Moisture Removal		L/h	0.9	1.2	1.9
Running Current (Rated)		A	2.8	3.9	4.9
Power Consumption Rated (Min.~Max.)		W	500 (300~980)	695 (300~980)	1,060 (300~1,300)
Power Factor		%	79.6	79.3	94.3
COP (Rated)		W/W	4.00	3.60	3.21
Piping Connections	Liquid	mm	φ 6.4	φ 6.4	φ 6.4
	Gas	mm	φ 9.5	φ 9.5	φ 9.5
	Drain	mm	φ18.0	φ18.0	φ 18.0
Heat Insulation			Both Liquid and Gas Pipes	Both Liquid and Gas Pipes	Both Liquid and Gas Pipes
Indoor Units			FTKS20CVMB(9)	FTKS25CVMB(9)(8)	FTKS35CVMB(9)(8)
Front Panel Color			White	White	White
Air Flow Rate	m³/min (cfm)	H	7.7 (272)	7.7 (272)	7.7 (272)
		M	5.9 (208)	5.9 (208)	6.0 (212)
		L	4.2 (148)	4.2 (148)	4.4 (155)
		SL	3.6 (127)	3.6 (127)	3.8 (134)
Fan	Type	Cross Flow Fan			
	Motor Output	W	18	18	
	Speed	Steps	5 Steps, Silent and Auto	5 Steps, Silent and Auto	
Air Direction Control			Right, Left, Horizontal and Downward	Right, Left, Horizontal and Downward	Right, Left, Horizontal and Downward
Air Filter			Removable / Washable / Mildew Proof	Removable / Washable / Mildew Proof	Removable / Washable / Mildew Proof
Running Current (Rated)		A	0.18	0.18	0.18
Power Consumption (Rated)		W	40	40	40
Power Factor		%	96.6	96.6	96.6
Temperature Control			Microcomputer Control	Microcomputer Control	Microcomputer Control
Dimensions (HxWxD)		mm	273x784x195	273x784x195	273x784x195
Packaged Dimensions (WxDxH)		mm	834x325x258	834x325x258	834x325x258
Weight		kg	7.5	7.5	7.5
Gross Weight		kg	11	11	11
Operation Sound	H/M/L/SL	dBA	38 / 32 / 25 / 22	38 / 32 / 25 / 22	39 / 33 / 26 / 23
Sound Power	H	dBA	56	56	57
Outdoor Units			RKS20CVMB	RKS25CVMB	RKS35CVMB
Casing Color			Ivory White	Ivory White	Ivory White
Compressor	Type	Hermetically Sealed Swing Type			
	Model	1YC23NXD#A			
	Motor Output	W	600	600	
Refrigerant Oil	Type	FVC50K			
	Charge	L	0.375	0.375	
Refrigerant	Type	R410A			
	Charge	kg	0.80	1.00	
Air Flow Rate	m³/min (cfm)	H	34 (1,201)	34 (1,201)	
		L	24.8 (876)	24.8 (876)	
Fan	Type	Propeller			
	Motor Output	W	31	35	
Running Current (Rated)		A	2.62	4.72	
Power Consumption (Rated)		W	460	1,020	
Power Factor		%	76.3	94.0	
Starting Current		A	3.5	5.4	
Dimensions (HxWxD)		mm	550x765x285	550x765x285	
Packaged Dimensions (WxDxH)		mm	882x363x589	882x363x589	
Weight		kg	30	32	
Gross Weight		kg	35	38	
Operation Sound	H / L	dBA	46 / 43	46 / 43	
Sound Power	H	dBA	61	62	
Drawing No.			3D044242B	3D044243B	3D044244B

- Notes:**
- MAX. interunit piping length: 20m
 - MAX. interunit height difference: 15m
 - Amount of additional charge of refrigerant 20g/m for piping length exceeding 10m
 - The data are based on the conditions shown in the table below.

Cooling	Piping Length
Indoor ; 27°CDB/19°CWB Outdoor ; 35°CDB/24°CWB	7.5m

Conversion Formulae
kcal/h=kW×860 Btu/h=kW×3414 cfm=m³/min×35.3

230V, 50Hz

Models	Indoor Units		ATKS20CVMB(9)	ATKS25CVMB(9)	ATKS35CVMB(9)
	Outdoor Units		ARKS20CVMB	ARKS25CVMB	ARKS35CVMB
Capacity Rated (Min.-Max.)	kW		2.0 (1.3~3.0)	2.5 (1.3~3.0)	3.4 (1.4~3.8)
	Btu/h		6,800 (4,450~10,250)	8,550 (4,450~10,250)	11,600 (4,750~12,950)
	kcal/h		1,720 (1,120~2,580)	2,150 (1,120~2,580)	2,920 (1,200~3,270)
Moisture Removal	L/h		0.9	1.2	1.9
Running Current (Rated)	A		2.8	3.9	4.9
Power Consumption Rated (Min.-Max.)	W		500 (300~980)	695 (300~980)	1,060 (300~1,300)
Power Factor	%		79.6	79.3	94.3
COP (Rated)	W/W		4.00	3.60	3.21
Piping Connections	Liquid	mm	φ 6.4	φ 6.4	φ 6.4
	Gas	mm	φ 9.5	φ 9.5	φ 9.5
	Drain	mm	φ 18.0	φ 18.0	φ 18.0
Heat Insulation			Both Liquid and Gas Pipes	Both Liquid and Gas Pipes	Both Liquid and Gas Pipes
Indoor Units			ATKS20CVMB(9)	ATKS25CVMB(9)	ATKS35CVMB(9)
Front Panel Color			White	White	White
Air Flow Rate	m³/min (cfm)	H	7.7 (272)	7.7 (272)	7.7 (272)
		M	5.9 (208)	5.9 (208)	6.1 (215)
		L	4.2 (148)	4.2 (148)	4.4 (155)
		SL	3.6 (127)	3.6 (127)	3.8 (134)
Fan	Type		Cross Flow Fan	Cross Flow Fan	Cross Flow Fan
	Motor Output	W	18	18	18
	Speed	Steps	5 Steps, Silent and Auto	5 Steps, Silent and Auto	5 Steps, Silent and Auto
Air Direction Control			Right, Left, Horizontal and Downward	Right, Left, Horizontal and Downward	Right, Left, Horizontal and Downward
Air Filter			Removable / Washable / Mildew Proof	Removable / Washable / Mildew Proof	Removable / Washable / Mildew Proof
Running Current (Rated)	A		0.18	0.18	0.18
Power Consumption (Rated)	W		40	40	40
Power Factor	%		96.6	96.6	96.6
Temperature Control			Microcomputer Control	Microcomputer Control	Microcomputer Control
Dimensions (HxWxD)	mm		273x784x185	273x784x185	273x784x185
Packaged Dimensions (WxDxH)	mm		834x325x258	834x325x258	834x325x258
Weight	kg		7.5	7.5	7.5
Gross Weight	kg		11	11	11
Operation Sound	H/M/L/SL	dBA	38 / 32 / 25 / 22	38 / 32 / 25 / 22	39 / 33 / 26 / 23
Sound Power	H	dBA	56	56	57
Outdoor Units			ARKS20CVMB	ARKS25CVMB	ARKS35CVMB
Casing Color			Ivory White	Ivory White	Ivory White
Compressor	Type		Hermetically Sealed Swing Type	Hermetically Sealed Swing Type	Hermetically Sealed Swing Type
	Model		1YC23NXD#A	1YC23NXD#A	1YC23NXD#A
	Motor Output	W	600	600	600
Refrigerant Oil	Type		FVC50K	FVC50K	FVC50K
	Charge	L	0.375	0.375	0.375
Refrigerant	Type		R410A	R410A	R410A
	Charge	kg	0.80	0.80	1.00
Air Flow Rate	m³/min (cfm)	H	34 (1,201)	34 (1,201)	31.3 (1,105)
		L	24.8 (876)	24.8 (876)	22.4 (791)
Fan	Type		Propeller	Propeller	Propeller
	Motor Output	W	31	31	35
Running Current (Rated)	A		2.62	3.72	4.72
Power Consumption (Rated)	W		460	655	1,020
Power Factor	%		76.3	76.6	94.0
Starting Current	A		3.5	4.4	5.4
Dimensions (HxWxD)	mm		550x765x285	550x765x285	550x765x285
Packaged Dimensions (WxDxH)	mm		882x363x589	882x363x589	882x363x589
Weight	kg		30	30	32
Gross Weight	kg		35	35	38
Operation Sound	H / L	dBA	46 / 43	46 / 43	47 / 44
Sound Power	H	dBA	61	61	62
Drawing No.			3D044248B	3D044249B	3D044250B

Notes:

- MAX. interunit piping length: 20m
- MAX. interunit height difference: 15m
- Amount of additional charge of refrigerant 20g/m for piping length exceeding 10m
- The data are based on the conditions shown in the table below.

Cooling	Piping Length
Indoor ; 27°CDB/19°CWB Outdoor ; 35°CDB/24°CWB	7.5m

Conversion Formulae

kcal/h=kWx860
Btu/h=kWx3414
cfm=m³/minx35.3

1.1.2 Standard Grade Models

230V, 50Hz

Models	Indoor Units		FTKS20CVMB(9)	FTKS25CVMB(9)(8)	FTKS35CVMB(9)(8)
	Outdoor Units		RKH20CVMB9	RKH25CVMB9	RKH35CVMB9
Capacity Rated (Min.-Max.)		kW	2.0 (1.3~2.6)	2.25 (1.3~3.0)	3.15 (1.4~3.8)
		Btu/h	6,800 (4,450~8,850)	7,650 (4,450~10,250)	10,750 (4,750~12,950)
		kcal/h	1,720 (1,120~2,240)	1,940 (1,120~2,580)	2,710 (1,200~3,270)
Moisture Removal		L/h	0.9	1.2	1.7
Running Current (Rated)		A	3.3	3.7	4.9
Power Consumption Rated (Min.-Max.)		W	620 (430~945)	700 (430~1,200)	1,045 (460~1,425)
Power Factor		%	81.7	82.3	92.7
COP (Rated)		W/W	3.23	3.21	3.01
Piping Connections	Liquid	mm	φ 6.4	φ 6.4	φ 6.4
	Gas	mm	φ 9.5	φ 9.5	φ 9.5
	Drain	mm	φ 18.0	φ 18.0	φ 18.0
Heat Insulation			Both Liquid and Gas Pipes	Both Liquid and Gas Pipes	Both Liquid and Gas Pipes
Indoor Units			FTKS20CVMB(9)	FTKS25CVMB(9)(8)	FTKS35CVMB(9)(8)
Front Panel Color			White	White	White
Air Flow Rate	m³/min (cfm)	H	7.7 (272)	7.7 (272)	7.7 (272)
		M	5.9 (208)	5.9 (208)	6.0 (212)
		L	4.2 (148)	4.2 (148)	4.4 (155)
		SL	3.6 (127)	3.6 (127)	3.8 (134)
Fan	Type		Cross Flow Fan	Cross Flow Fan	Cross Flow Fan
	Motor Output	W	18	18	18
	Speed	Steps	5 Steps, Silent and Auto	5 Steps, Silent and Auto	5 Steps, Silent and Auto
Air Direction Control			Right, Left, Horizontal and Downward	Right, Left, Horizontal and Downward	Right, Left, Horizontal and Downward
Air Filter			Removable / Washable / Mildew Proof	Removable / Washable / Mildew Proof	Removable / Washable / Mildew Proof
Running Current (Rated)		A	0.18	0.18	0.18
Power Consumption (Rated)		W	40	40	40
Power Factor		%	96.6	96.6	96.6
Temperature Control			Microcomputer Control	Microcomputer Control	Microcomputer Control
Dimensions (HxWxD)		mm	273x784x195	273x784x195	273x784x195
Packaged Dimensions (WxDxH)		mm	834x325x258	834x325x258	834x325x258
Weight		kg	7.5	7.5	7.5
Gross Weight		kg	11	11	11
Operation Sound	H/M/L/SL	dBA	38 / 32 / 25 / 22	38 / 32 / 25 / 22	39 / 33 / 26 / 23
Sound Power	H	dBA	56	56	57
Outdoor Units			RKH20CVMB9	RKH25CVMB9	RKH35CVMB9
Casing Color			Ivory White	Ivory White	Ivory White
Compressor	Type		Hermetically Sealed Swing Type	Hermetically Sealed Swing Type	Hermetically Sealed Swing Type
	Model		1YC23NXD#A	1YC23NXD#A	1YC23NXD#A
	Motor Output	W	600	600	600
Refrigerant Oil	Type		FVC50K	FVC50K	FVC50K
	Charge	L	0.375	0.375	0.375
Refrigerant	Type		R410A	R410A	R410A
	Charge	kg	0.79	0.79	1.01
Air Flow Rate	m³/min (cfm)	H	29 (1,025)	29 (1,025)	27.5 (972)
		L	—	—	—
Fan	Type		Propeller	Propeller	Propeller
	Motor Output	W	25	25	25
Running Current (Rated)		A	3.12	3.52	4.72
Power Consumption (Rated)		W	580	660	1,005
Power Factor		%	80.8	81.5	92.6
Starting Current		A	3.3	3.7	4.9
Dimensions (HxWxD)		mm	560x695x265	560x695x265	560x695x265
Packaged Dimensions (WxDxH)		mm	824x337x599	824x337x599	824x337x599
Weight		kg	31	31	33
Gross Weight		kg	36	36	38
Operation Sound	H/L	dBA	46 / —	46 / —	48 / —
Sound Power	H	dBA	61	61	63
Drawing No.			C:3D044455	C:3D044456	C:3D044457

Notes:

- MAX. interunit piping length: 15m
- MAX. interunit height difference: 15m
- Amount of additional charge of refrigerant 20g/m for piping length exceeding 10m
- The data are based on the conditions shown in the table below.

Cooling	Piping Length
Indoor ; 27°CDB/19°CWB Outdoor ; 35°CDB/24°CWB	7.5m

Conversion Formulae

kcal/h=kWx860
Btu/h=kWx3414
cfm=m³/minx35.3

230V, 50Hz

Models	Indoor Units		ATKS20CVMB(9)	ATKS25CVMB(9)	ATKS35CVMB(9)
	Outdoor Units		ARKH20CVMB9	ARKH25CVMB9	ARKH35CVMB9
Capacity Rated (Min.~Max.)		kW	2.0 (1.3-2.6)	2.25 (1.3-3.0)	3.15 (1.4-3.8)
		Btu/h	6,800 (4,450-8,850)	7,650 (4,450-10,250)	10,750 (4,750-12,950)
		kcal/h	1,720 (1,120-2,240)	1,940 (1,120-2,580)	2,710 (1,200-3,270)
Moisture Removal		L/h	0.9	1.2	1.7
Running Current (Rated)		A	3.3	3.7	4.9
Power Consumption Rated (Min.~Max.)		W	620 (430-945)	700 (430-1,200)	1,045 (460-1,425)
Power Factor		%	81.7	82.3	92.7
COP (Rated)		W/W	3.23	3.21	3.01
Piping Connections	Liquid	mm	φ 6.4	φ 6.4	φ 6.4
	Gas	mm	φ 9.5	φ 9.5	φ 9.5
	Drain	mm	φ 18.0	φ 18.0	φ 18.0
Heat Insulation			Both Liquid and Gas Pipes	Both Liquid and Gas Pipes	Both Liquid and Gas Pipes
Indoor Units			ATKS20CVMB(9)	ATKS25CVMB(9)	ATKS35CVMB(9)
Front Panel Color			White	White	White
Air Flow Rate	m³/min (cfm)	H	7.7 (272)	7.7 (272)	7.7 (272)
		M	5.9 (208)	5.9 (208)	6.1 (215)
		L	4.2 (148)	4.2 (148)	4.4 (155)
		SL	3.6 (127)	3.6 (127)	3.8 (134)
Fan	Type		Cross Flow Fan	Cross Flow Fan	Cross Flow Fan
	Motor Output	W	18	18	18
	Speed	Steps	5 Steps, Silent and Auto	5 Steps, Silent and Auto	5 Steps, Silent and Auto
Air Direction Control			Right, Left, Horizontal and Downward	Right, Left, Horizontal and Downward	Right, Left, Horizontal and Downward
Air Filter			Removable / Washable / Mildew Proof	Removable / Washable / Mildew Proof	Removable / Washable / Mildew Proof
Running Current (Rated)		A	0.18	0.18	0.18
Power Consumption (Rated)		W	40	40	40
Power Factor		%	96.6	96.6	96.6
Temperature Control			Microcomputer Control	Microcomputer Control	Microcomputer Control
Dimensions (HxWxD)		mm	273x784x185	273x784x185	273x784x185
Packaged Dimensions (WxDxH)		mm	834x325x258	834x325x258	834x325x258
Weight		kg	7.5	7.5	7.5
Gross Weight		kg	11	11	11
Operation Sound	H/M/L/SL	dBA	38 / 32 / 25 / 22	38 / 32 / 25 / 22	39 / 33 / 26 / 23
Sound Power	H	dBA	56	56	57
Outdoor Units			ARKH20CVMB9	ARKH25CVMB9	ARKH35CVMB9
Casing Color			Ivory White	Ivory White	Ivory White
Compressor	Type		Hermetically Sealed Swing Type	Hermetically Sealed Swing Type	Hermetically Sealed Swing Type
	Model		1YC23NXD#A	1YC23NXD#A	1YC23NXD#A
	Motor Output	W	600	600	600
Refrigerant Oil	Type		FVC50K	FVC50K	FVC50K
	Charge	L	0.375	0.375	0.375
Refrigerant	Type		R410A	R410A	R410A
	Charge	kg	0.79	0.79	1.01
Air Flow Rate	m³/min (cfm)	H	29 (1,025)	29 (1,025)	27.5 (972)
		L	—	—	—
Fan	Type		Propeller	Propeller	Propeller
	Motor Output	W	25	25	25
Running Current (Rated)		A	3.12	3.52	4.72
Power Consumption (Rated)		W	580	660	1,005
Power Factor		%	80.8	81.5	92.6
Starting Current		A	3.3	3.7	4.9
Dimensions (HxWxD)		mm	560x695x265	560x695x265	560x695x265
Packaged Dimensions (WxDxH)		mm	824x337x599	824x337x599	824x337x599
Weight		kg	31	31	33
Gross Weight		kg	36	36	38
Operation Sound	H/L	dBA	46 / —	46 / —	48 / —
Sound Power	H	dBA	61	61	63
Drawing No.			C:3D044458	C:3D044459	C:3D044460

Notes:

- MAX. interunit piping length: 15m
- MAX. interunit height difference: 15m
- Amount of additional charge of refrigerant 20g/m for piping length exceeding 10m
- The data are based on the conditions shown in the table below.

Cooling	Piping Length
Indoor ; 27°CDB/19°CWB Outdoor ; 35°CDB/24°CWB	7.5m

Conversion Formulae

kcal/h=kWx860
Btu/h=kWx3414
cfm=m³/minx35.3

1.1.3 Non-Inverter Models

230V, 50Hz

Models	Indoor Units		FTN20CVMB9	FTN25CVMB9	FTN35CVMB9
	Outdoor Units		RN20CVMB9	RN25CVMB9	RN35CVMB9
Capacity Rated (Min.~Max.)		kW	2.0	2.25	3.15
		Btu/h	6,800	7,650	10,750
		kcal/h	1,720	1,940	2,710
Moisture Removal		L/h	0.9	1.2	1.7
Running Current (Rated)		A	3.3	3.7	4.9
Power Consumption Rated (Min.~Max.)		W	620	700	1,045
Power Factor		%	81.7	82.3	92.7
COP (Rated)		W/W	3.23	3.21	3.01
Piping Connections	Liquid	mm	φ 6.4	φ 6.4	φ 6.4
	Gas	mm	φ 9.5	φ 9.5	φ 9.5
	Drain	mm	φ 18.0	φ 18.0	φ 18.0
Heat Insulation			Both Liquid and Gas Pipes	Both Liquid and Gas Pipes	Both Liquid and Gas Pipes
Indoor Units			FTN20CVMB9	FTN25CVMB9	FTN35CVMB9
Front Panel Color			White	White	White
Air Flow Rate	m³/min (cfm)	H	7.7 (272)	7.7 (272)	7.7 (272)
		M	5.9 (208)	5.9 (208)	6.1 (215)
		L	4.2 (148)	4.2 (148)	4.4 (155)
		SL	—	—	—
Fan	Type		Cross Flow Fan	Cross Flow Fan	Cross Flow Fan
	Motor Output	W	18	18	18
	Speed	Steps	5 Steps and Auto	5 Steps and Auto	5 Steps and Auto
Air Direction Control			Right, Left, Horizontal and Downward	Right, Left, Horizontal and Downward	Right, Left, Horizontal and Downward
Air Filter			Removable / Washable / Mildew Proof	Removable / Washable / Mildew Proof	Removable / Washable / Mildew Proof
Running Current (Rated)		A	0.18	0.18	0.18
Power Consumption (Rated)		W	40	40	40
Power Factor		%	96.6	96.6	96.6
Temperature Control			Microcomputer Control	Microcomputer Control	Microcomputer Control
Dimensions (HxWxD)		mm	273x784x185	273x784x185	273x784x185
Packaged Dimensions (WxDxH)		mm	834x325x258	834x325x258	834x325x258
Weight		kg	7.5	7.5	7.5
Gross Weight		kg	11	11	11
Operation Sound	H/M/L/SL	dBA	38 / 32 / 26 / —	38 / 32 / 26 / —	39 / 33 / 26 / —
Sound Power	H	dBA	56	56	57
Outdoor Units			RN20CVMB9	RN25CVMB9	RN35CVMB9
Casing Color			Ivory White	Ivory White	Ivory White
Compressor	Type		Hermetically Sealed Swing Type	Hermetically Sealed Swing Type	Hermetically Sealed Swing Type
	Model		1YC23NXD#A	1YC23NXD#A	1YC23NXD#A
	Motor Output	W	600	600	600
Refrigerant Oil	Type		FVC50K	FVC50K	FVC50K
	Charge	L	0.375	0.375	0.375
Refrigerant	Type		R410A	R410A	R410A
	Charge	kg	0.79	0.79	1.01
Air Flow Rate	m³/min (cfm)	H	29 (1,025)	29 (1,025)	27.5 (972)
		L	—	—	—
Fan	Type		Propeller	Propeller	Propeller
	Motor Output	W	25	25	25
Running Current (Rated)		A	3.12	3.52	4.72
Power Consumption (Rated)		W	580	660	1,005
Power Factor		%	80.8	81.5	92.6
Starting Current		A	3.3	3.7	4.9
Dimensions (HxWxD)		mm	560x695x265	560x695x265	560x695x265
Packaged Dimensions (WxDxH)		mm	824x337x599	824x337x599	824x337x599
Weight		kg	31	31	33
Gross Weight		kg	36	36	38
Operation Sound	H/L	dBA	46 / —	46 / —	48 / —
Sound Power	H	dBA	61	61	63
Drawing No.			3D044461	3D044462	3D044463

Notes:

- MAX. interunit piping length: 15m
- MAX. interunit height difference: 15m
- Amount of additional charge of refrigerant 20g/m for piping length exceeding 10m
- The data are based on the conditions shown in the table below.

Cooling	Piping Length
Indoor ; 27°CDB/19°CWB Outdoor ; 35°CDB/24°CWB	7.5m

Conversion Formulae

kcal/h=kWx860
Btu/h=kWx3414
cfm=m³/minx35.3

1.2 Heat Pump

1.2.1 High Grade Models

230V, 50Hz

Models	Indoor Units		FTXS20CVMB(9)		FTXS25CVMB(9)(8)	
	Outdoor Units		RXS20CVMB		RXS25CVMB	
			Cooling	Heating	Cooling	Heating
Capacity Rated (Min.-Max.)	kW		2.0 (1.3-3.0)	2.7 (1.3-4.5)	2.5 (1.3-3.0)	3.4 (1.3-4.5)
	Btu/h		6,800 (4,450-10,250)	9,200 (4,450-15,350)	8,550 (4,450-10,250)	11,600 (4,450-15,350)
	kcal/h		1,720 (1,120-2,580)	2,320 (1,120-3,870)	2,150 (1,120-2,580)	2,920 (1,120-3,870)
Moisture Removal	L/h		0.9	—	1.2	—
Running Current (Rated)	A		2.8	3.5	3.9	4.4
Power Consumption Rated (Min.-Max.)	W		500 (300-980)	675 (290-1,460)	695 (300-980)	935 (290-1,460)
Power Factor	%		79.6	82.1	79.3	93.7
COP (Rated)	W/W		4.00	4.00	3.60	3.64
Piping Connections	Liquid	mm	φ 6.4		φ 6.4	
	Gas	mm	φ 9.5		φ 9.5	
	Drain	mm	φ 18.0		φ 18.0	
Heat Insulation	Both Liquid and Gas Pipes				Both Liquid and Gas Pipes	
Indoor Units		FTXS20CVMB(9)		FTXS25CVMB(9)(8)		
Front Panel Color		White		White		
Air Flow Rate	m ³ /min (cfm)	H	7.7 (272)	7.8 (275)	7.7 (272)	7.8 (275)
		M	5.9 (208)	6.5 (230)	5.9 (208)	6.5 (230)
		L	4.2 (148)	5.3 (187)	4.2 (148)	5.3 (187)
		SL	3.6 (127)	4.6 (162)	3.6 (127)	4.6 (162)
Fan	Type	Cross Flow Fan		Cross Flow Fan		
	Motor Output	W	18		18	
	Speed	Steps	5 Steps, Silent and Auto		5 Steps, Silent and Auto	
Air Direction Control		Right, Left, Horizontal and Downward		Right, Left, Horizontal and Downward		
Air Filter		Removable / Washable / Mildew Proof		Removable / Washable / Mildew Proof		
Running Current (Rated)	A	0.18	0.18	0.18	0.18	
Power Consumption (Rated)	W	40	40	40	40	
Power Factor	%	96.6	96.6	96.6	96.6	
Temperature Control		Microcomputer Control		Microcomputer Control		
Dimensions (HxWxD)	mm	273x784x195		273x784x195		
Packaged Dimensions (WxDxH)	mm	834x325x258		834x325x258		
Weight	kg	7.5		7.5		
Gross Weight	kg	11		11		
Operation Sound	H/M/L/SL	dBA	38 / 32 / 25 / 22	38 / 33 / 28 / 25	38 / 32 / 25 / 22	38 / 33 / 28 / 25
Sound Power	H	dBA	56	56	56	56
Outdoor Units		RXS20CVMB		RXS25CVMB		
Casing Color		Ivory White		Ivory White		
Compressor	Type	Hermetically Sealed Swing Type		Hermetically Sealed Swing Type		
	Model	1YC23NXD#A		1YC23NXD#A		
	Motor Output	W	600		600	
Refrigerant Oil	Type	FVC50K		FVC50K		
	Charge	L	0.375		0.375	
Refrigerant	Type	R410A		R410A		
	Charge	kg	0.80		0.80	
Air Flow Rate	m ³ /min (cfm)	H	34 (1,201)	30.6 (1,080)	34 (1,201)	30.6 (1,080)
		L	24.8 (876)	24.7 (872)	24.8 (876)	24.7 (872)
Fan	Type	Propeller		Propeller		
	Motor Output	W	31		31	
Running Current (Rated)	A	2.62	3.32	3.72	4.22	
Power Consumption (Rated)	W	460	635	655	895	
Power Factor	%	76.3	83.2	76.6	92.2	
Starting Current	A	3.5		4.4		
Dimensions (HxWxD)	mm	550x765x285		550x765x285		
Packaged Dimensions (WxDxH)	mm	882x363x589		882x363x589		
Weight	kg	30		30		
Gross Weight	kg	35		35		
Operation Sound	H/L	dBA	46 / 43	47 / 44	46 / 43	47 / 44
Sound Power	H	dBA	61	62	61	62
Drawing No.			3D044245B		3D044246B	

Notes:

- MAX. interunit piping length: 20m
- MAX. interunit height difference: 15m
- Amount of additional charge of refrigerant 20g/m for piping length exceeding 10m
- The data are based on the conditions shown in the table below.

Cooling	Heating	Piping Length
Indoor ; 27°CDB/19°CWB Outdoor ; 35°CDB/24°CWB	Indoor ; 20°CDB Outdoor ; 7°CDB/6°CWB	7.5m

Conversion Formulae

$$\begin{aligned} \text{kcal/h} &= \text{kW} \times 860 \\ \text{Btu/h} &= \text{kW} \times 3414 \\ \text{cfm} &= \text{m}^3/\text{min} \times 35.3 \end{aligned}$$

Models	Indoor Units		FTXS35CVMB(9)(8)	
	Outdoor Units		RXS35CVMB	
			Cooling	Heating
Capacity Rated (Min.~Max.)	kW		3.4 (1.4~3.8)	
	Btu/h		11,600 (4,750~12,950)	
	kcal/h		2,920 (1,200~3,270)	
Moisture Removal	L/h		1.9	
Running Current (Rated)	A		4.9	
Power Consumption Rated (Min.~Max.)	W		1,060 (300~1,300)	
Power Factor	%		94.3	
COP (Rated)	W/W		3.21	
Piping Connections	Liquid	mm	φ 6.4	
	Gas	mm	φ 9.5	
	Drain	mm	φ 18.0	
Heat Insulation		Both Liquid and Gas Pipes		
Indoor Units		FTXS35CVMB(9)(8)		
Front Panel Color		White		
Air Flow Rate	m³/min (cfm)	H	7.7 (272)	
		M	6.0 (212)	
		L	4.4 (155)	
		SL	3.8 (134)	
Fan	Type	Cross Flow Fan		
	Motor Output	W 18		
	Speed	Steps 5 Steps, Silent and Auto		
Air Direction Control		Right, Left, Horizontal and Downward		
Air Filter		Removable / Washable / Mildew Proof		
Running Current (Rated)	A		0.18	
Power Consumption (Rated)	W		40	
Power Factor	%		96.6	
Temperature Control		Microcomputer Control		
Dimensions (HxWxD)	mm		273x784x195	
Packaged Dimensions (WxDxH)	mm		834x325x258	
Weight	kg		7.5	
Gross Weight	kg		11	
Operation Sound	H/M/L/SL	dBA	39 / 33 / 26 / 23	
Sound Power	H	dBA	57	
Outdoor Units		RXS35CVMB		
Casing Color		Ivory White		
Compressor	Type	Hermetically Sealed Swing Type		
	Model	1YC23NXD#A		
	Motor Output	W 600		
Refrigerant Oil	Type	FVC50K		
	Charge	L 0.375		
Refrigerant	Type	R410A		
	Charge	kg 1.00		
Air Flow Rate	m³/min (cfm)	H	31.3 (1,105)	
		L	22.4 (791)	
Fan	Type	Propeller		
	Motor Output	W 35		
Running Current (Rated)	A		4.72	
Power Consumption (Rated)	W		1,020	
Power Factor	%		94.0	
Starting Current	A		5.4	
Dimensions (HxWxD)	mm		550x765x285	
Packaged Dimensions (WxDxH)	mm		882x363x589	
Weight	kg		32	
Gross Weight	kg		38	
Operation Sound	H/L	dBA	47 / 44	
Sound Power		dBA	62	
Drawing No.	3D044247B			

Notes:

- MAX. interunit piping length: 20m
- MAX. interunit height difference: 15m
- Amount of additional charge of refrigerant 20g/m for piping length exceeding 10m
- The data are based on the conditions shown in the table below.

Cooling	Heating	Piping Length
Indoor ; 27°CDB/19°CWB Outdoor ; 35°CDB/24°CWB	Indoor ; 20°CDB Outdoor ; 7°CDB/6°CWB	7.5m

Conversion Formulae
kcal/h=kWx860 Btu/h=kWx3414 cfm=m³/minx35.3

230V, 50Hz

Models	Indoor Units		ATXS20CVMB(9)		ATXS25CVMB(9)	
	Outdoor Units		ARXS20CVMB		ARXS25CVMB	
			Cooling	Heating	Cooling	Heating
Capacity Rated (Min.~Max.)	kW		2.0 (1.3~3.0)	2.7 (1.3~4.5)	2.5 (1.3~3.0)	3.4 (1.3~4.5)
	Btu/h		6,800 (4,450~10,250)	9,200 (4,450~15,350)	8,550 (4,450~10,250)	11,600 (4,450~15,350)
	kcal/h		1,720 (1,120~2,580)	2,320 (1,120~3,870)	2,150 (1,120~2,580)	2,920 (1,120~3,870)
Moisture Removal	L/h		0.9	—	1.2	—
Running Current (Rated)	A		2.8	3.5	3.9	4.4
Power Consumption Rated (Min.~Max.)	W		500 (300~980)	675 (290~1,460)	695 (300~980)	935 (290~1,460)
Power Factor	%		79.6	82.1	79.3	93.7
COP (Rated)	W/W		4.00	4.00	3.60	3.64
Piping Connections	Liquid	mm	φ 6.4		φ 6.4	
	Gas	mm	φ 9.5		φ 9.5	
	Drain	mm	φ18.0		φ18.0	
Heat Insulation			Both Liquid and Gas Pipes		Both Liquid and Gas Pipes	
Indoor Units		ATXS20CVMB(9)		ATXS25CVMB(9)		
Front Panel Color		White		White		
Air Flow Rate	m³/min (cfm)	H	7.7 (272)	7.8 (275)	7.7 (272)	7.8 (275)
		M	5.9 (208)	6.5 (230)	5.9 (208)	6.5 (230)
		L	4.2 (148)	5.3 (187)	4.2 (148)	5.3 (187)
		SL	3.6 (127)	4.6 (162)	3.6 (127)	4.6 (162)
Fan	Type	Cross Flow Fan		Cross Flow Fan		
	Motor Output	W	18		18	
	Speed	Steps	5 Steps, Silent and Auto		5 Steps, Silent and Auto	
Air Direction Control		Right, Left, Horizontal and Downward		Right, Left, Horizontal and Downward		
Air Filter		Removable / Washable / Mildew Proof		Removable / Washable / Mildew Proof		
Running Current (Rated)	A	0.18		0.18		
Power Consumption (Rated)	W	40		40		
Power Factor	%	96.6		96.6		
Temperature Control		Microcomputer Control		Microcomputer Control		
Dimensions (HxWxD)	mm	273x784x185		273x784x185		
Packaged Dimensions (WxDxH)	mm	834x325x258		834x325x258		
Weight	kg	7.5		7.5		
Gross Weight	kg	11		11		
Operation Sound	H/M/L/SL	dBA	38 / 32 / 25 / 22	38 / 33 / 28 / 25	38 / 32 / 25 / 22	38 / 33 / 28 / 25
Sound Power	H	dBA	56	56	56	56
Outdoor Units		ARXS20CVMB		ARXS25CVMB		
Casing Color		Ivory White		Ivory White		
Compressor	Type	Hermetically Sealed Swing Type		Hermetically Sealed Swing Type		
	Model	1YC23NXD#A		1YC23NXD#A		
Refrigerant Oil	Motor Output	W	600		600	
	Type	FVC50K		FVC50K		
Refrigerant	Charge	L	0.375		0.375	
	Type	R410A		R410A		
Air Flow Rate	m³/min (cfm)	H	34 (1,201)	30.6 (1,080)	34 (1,201)	30.6 (1,080)
		L	24.8 (876)	24.7 (872)	24.8 (876)	24.7 (872)
Fan	Type	Propeller		Propeller		
	Motor Output	W	31		31	
Running Current (Rated)	A	2.62	3.32	3.72	4.22	
Power Consumption (Rated)	W	460	635	655	895	
Power Factor	%	76.3	83.2	76.6	92.2	
Starting Current	A	3.5		4.4		
Dimensions (HxWxD)	mm	550x765x285		550x765x285		
Packaged Dimensions (WxDxH)	mm	882x363x589		882x363x589		
Weight	kg	30		30		
Gross Weight	kg	35		35		
Operation Sound	H/L	dBA	46 / 43	47 / 44	46 / 43	47 / 44
Sound Power	H	dBA	61	62	61	62
Drawing No.			3D044251B		3D044252B	

Notes:

- MAX. interunit piping length: 20m
- MAX. interunit height difference: 15m
- Amount of additional charge of refrigerant 20g/m for piping length exceeding 10m
- The data are based on the conditions shown in the table below.

Cooling	Heating	Piping Length
Indoor ; 27°CDB/19°CWB Outdoor ; 35°CDB/24°CWB	Indoor ; 20°CDB Outdoor ; 7°CDB/6°CWB	7.5m

Conversion Formulae
kcal/h=kWx860 Btu/h=kWx3414 cfm=m³/minx35.3

230V, 50Hz

Models	Indoor Units		ATXS35CVMB(9)	
	Outdoor Units		ARXS35CVMB	
			Cooling	Heating
Capacity Rated (Min.~Max.)	kW		3.4 (1.4~3.8)	
	Btu/h		11,600 (4,750~12,950)	
	kcal/h		2,920 (1,200~3,270)	
Moisture Removal	L/h		1.9	
Running Current (Rated)	A		4.9	
Power Consumption Rated (Min.~Max.)	W		1,060 (300~1,300)	
Power Factor	%		94.3	
COP (Rated)	W/W		3.21	
Piping Connections	Liquid	mm	φ 6.4	
	Gas	mm	φ 9.5	
	Drain	mm	φ 18.0	
Heat Insulation		Both Liquid and Gas Pipes		
Indoor Units		ATXS35CVMB(9)		
Front Panel Color		White		
Air Flow Rate	m³/min (cfm)	H	7.7 (272)	
		M	6.1 (215)	
		L	4.4 (155)	
		SL	3.8 (134)	
Fan	Type	Cross Flow Fan		
	Motor Output	W 18		
	Speed	Steps 5 Steps, Silent and Auto		
Air Direction Control		Right, Left, Horizontal and Downward		
Air Filter		Removable / Washable / Mildew Proof		
Running Current (Rated)	A		0.18	
Power Consumption (Rated)	W		40	
Power Factor	%		96.6	
Temperature Control		Microcomputer Control		
Dimensions (HxWxD)		mm 273x784x185		
Packaged Dimensions (WxDxH)		mm 834x325x258		
Weight		kg 7.5		
Gross Weight		kg 11		
Operation Sound	H/M/L/SL	dBA 39 / 33 / 26 / 23		39 / 34 / 29 / 26
Sound Power	H	dBA 57		57
Outdoor Units		ARXS35CVMB		
Casing Color		Ivory White		
Compressor	Type	Hermetically Sealed Swing Type		
	Model	1YC23NXD#A		
	Motor Output	W 600		
Refrigerant Oil	Type	FVC50K		
	Charge	L 0.375		
Refrigerant	Type	R410A		
	Charge	kg 1.00		
Air Flow Rate	m³/min (cfm)	H	31.3 (1,105)	
		L	22.4 (791)	
Fan	Type	Propeller		
	Motor Output	W 35		
Running Current (Rated)	A		4.72	
Power Consumption (Rated)	W		1,020	
Power Factor	%		94.0	
Starting Current	A		5.4	
Dimensions (HxWxD)		mm 550x765x285		
Packaged Dimensions (WxDxH)		mm 882x363x589		
Weight		kg 32		
Gross Weight		kg 38		
Operation Sound	H/L	dBA 47 / 44		48 / 45
Sound Power	H	dBA 62		63
Drawing No.		3D044253B		

Notes:

- MAX. interunit piping length: 20m
- MAX. interunit height difference: 15m
- Amount of additional charge of refrigerant 20g/m for piping length exceeding 10m
- The data are based on the conditions shown in the table below.

Cooling	Heating	Piping Length
Indoor ; 27°CDB/19°CWB Outdoor ; 35°CDB/24°CWB	Indoor ; 20°CDB Outdoor ; 7°CDB/6°CWB	7.5m

Conversion Formulae

kcal/h=kWx860
Btu/h=kWx3414
cfm=m³/minx35.3

1.2.2 Standard Grade Models

230V, 50Hz

Models	Indoor Units		FTXS20CVMB(9)		FTXS25CVMB(9)(8)	
	Outdoor Units		RXH20CVMB9		RXH25CVMB9	
			Cooling	Heating	Cooling	Heating
Capacity Rated (Min.-Max.)	kW		2.0 (1.3~2.6)	2.6 (1.3~4.0)	2.25 (1.3~3.0)	2.85 (1.3~4.5)
	Btu/h		6,800 (4,450~8,850)	8,850 (4,450~13,650)	7,650 (4,450~10,250)	9,700 (4,450~15,350)
	kcal/h		1,720 (1,120~2,240)	2,240 (1,120~3,440)	1,940 (1,120~2,580)	2,450 (1,120~3,870)
Moisture Removal	L/h		0.9	—	1.2	—
Running Current (Rated)	A		3.3	4.0	3.7	4.4
Power Consumption Rated (Min.-Max.)	W		620 (430~945)	760 (350~1,310)	700 (430~1,200)	835 (350~1,610)
Power Factor	%		81.7	82.6	82.3	82.5
COP (Rated)	W/W		3.23	3.42	3.21	3.41
Piping Connections	Liquid	mm	φ 6.4		φ 6.4	
	Gas	mm	φ 9.5		φ 9.5	
	Drain	mm	φ 18.0		φ 18.0	
Heat Insulation			Both Liquid and Gas Pipes		Both Liquid and Gas Pipes	
Indoor Units		FTXS20CVMB(9)		FTXS25CVMB(9)(8)		
Front Panel Color		White		White		
Air Flow Rate	m³/min (cfm)	H	7.7 (272)	7.8 (275)	7.7 (272)	7.8 (275)
		M	5.9 (208)	6.5 (230)	5.9 (208)	6.5 (230)
		L	4.2 (148)	5.3 (187)	4.2 (148)	5.3 (187)
		SL	3.6 (127)	4.6 (162)	3.6 (127)	4.6 (162)
Fan	Type	Cross Flow Fan		Cross Flow Fan		
	Motor Output	W	18		18	
	Speed	Steps	5 Steps, Silent and Auto		5 Steps, Silent and Auto	
Air Direction Control			Right, Left, Horizontal and Downward		Right, Left, Horizontal and Downward	
Air Filter			Removable / Washable / Mildew Proof		Removable / Washable / Mildew Proof	
Running Current (Rated)	A		0.18	0.18	0.18	0.18
Power Consumption (Rated)	W		40	40	40	40
Power Factor	%		96.6	96.6	96.6	96.6
Temperature Control			Microcomputer Control		Microcomputer Control	
Dimensions (HxWxD)	mm		273x784x195		273x784x195	
Packaged Dimensions (WxDxH)	mm		834x325x258		834x325x258	
Weight	kg		7.5		7.5	
Gross Weight	kg		11		11	
Operation Sound	H/M/L/SL	dBA	38 / 32 / 25 / 22	38 / 33 / 28 / 25	38 / 32 / 25 / 22	38 / 33 / 28 / 25
Sound Power	H	dBA	56	56	56	56
Outdoor Units		RXH20CVMB9		RXH25CVMB9		
Casing Color		Ivory White		Ivory White		
Compressor	Type	Hermetically Sealed Swing Type		Hermetically Sealed Swing Type		
	Model	1YC23NXD#A		1YC23NXD#A		
	Motor Output	W	600		600	
Refrigerant Oil	Type	FVC50K		FVC50K		
	Charge	L	0.375		0.375	
Refrigerant	Type	R410A		R410A		
	Charge	kg	0.79		0.79	
Air Flow Rate	m³/min (cfm)	H	29 (1,025)	25.5 (901)	29 (1,025)	25.5 (901)
		L	—	—	—	—
Fan	Type	Propeller		Propeller		
	Motor Output	W	25		25	
Running Current (Rated)	A		3.12	3.82	3.52	4.22
Power Consumption (Rated)	W		580	720	660	795
Power Factor	%		80.8	81.9	81.5	81.9
Starting Current	A		4.0		4.4	
Dimensions (HxWxD)	mm		560x695x265		560x695x265	
Packaged Dimensions (WxDxH)	mm		824x337x599		824x337x599	
Weight	kg		31		31	
Gross Weight	kg		36		36	
Operation Sound	H/L	dBA	46 / —	47 / —	46 / —	47 / —
Sound Power	H	dBA	61	62	61	62
Drawing No.			C:3D044446		C:3D044447	

- Notes:**
- MAX. interunit piping length: 15m
 - MAX. interunit height difference: 15m
 - Amount of additional charge of refrigerant 20g/m for piping length exceeding 10m
 - The data are based on the conditions shown in the table below.

Cooling	Heating	Piping Length
Indoor ; 27°CDB/19°CWB Outdoor ; 35°CDB/24°CWB	Indoor ; 20°CDB Outdoor ; 7°CDB/6°CWB	7.5m

Conversion Formulae

kcal/h=kWx860
Btu/h=kWx3414
cfm=m³/minx35.3

230V, 50Hz

Models	Indoor Units		FTXS35CVMB(9)(8)	
	Outdoor Units		RXH35CVMB9	
			Cooling	Heating
Capacity Rated (Min.~Max.)	kW		3.15 (1.4~3.8)	
	Btu/h		10,750 (4,750~12,950)	
	kcal/h		2,710 (1,200~3,270)	
Moisture Removal	L/h		1.7	
Running Current (Rated)	A		4.9	
Power Consumption Rated (Min.~Max.)	W		1,045 (460~1,425)	
Power Factor	%		92.7	
COP (Rated)	W/W		3.01	
Piping Connections	Liquid	mm	φ 6.4	
	Gas	mm	φ 9.5	
	Drain	mm	φ 18.0	
Heat Insulation	Both Liquid and Gas Pipes			
Indoor Units		FTXS35CVMB(9)(8)		
Front Panel Color		White		
Air Flow Rate	m³/min (cfm)	H	7.7 (272)	
		M	6.0 (212)	
		L	4.4 (155)	
		SL	3.8 (134)	
Fan	Type	Cross Flow Fan		
	Motor Output	W 18		
	Speed	Steps 5 Steps, Silent and Auto		
Air Direction Control		Right, Left, Horizontal and Downward		
Air Filter		Removable / Washable / Mildew Proof		
Running Current (Rated)	A		0.18	
Power Consumption (Rated)	W		40	
Power Factor	%		96.6	
Temperature Control		Microcomputer Control		
Dimensions (HxWxD)		mm 273x784x195		
Packaged Dimensions (WxDxH)		mm 834x325x258		
Weight		kg 7.5		
Gross Weight		kg 11		
Operation Sound	H/M/L/SL	dBA	39 / 33 / 26 / 23	
Sound Power	H	dBA	57	
Outdoor Units		RXH35CVMB9		
Casing Color		Ivory White		
Compressor	Type	Hermetically Sealed Swing Type		
	Model	1YC23NXD#A		
	Motor Output	W 600		
Refrigerant Oil	Type	FVC50K		
	Charge	L 0.375		
Refrigerant	Type	R410A		
	Charge	kg 1.01		
Air Flow Rate	m³/min (cfm)	H	27.5 (972)	
		L	—	
Fan	Type	Propeller		
	Motor Output	W 25		
Running Current (Rated)	A		4.72	
Power Consumption (Rated)	W		1,005	
Power Factor	%		92.6	
Starting Current	A		4.9	
Dimensions (HxWxD)		mm 560x695x265		
Packaged Dimensions (WxDxH)		mm 824x337x599		
Weight		kg 33		
Gross Weight		kg 38		
Operation Sound	H/L	dBA	48 / —	
Sound Power	H	dBA	63	
Drawing No.		C:3D04448		

Notes:

- MAX. interunit piping length: 15m
- MAX. interunit height difference: 15m
- Amount of additional charge of refrigerant 20g/m for piping length exceeding 10m
- The data are based on the conditions shown in the table below.

Cooling	Heating	Piping Length
Indoor ; 27°CDB/19°CWB Outdoor ; 35°CDB/24°CWB	Indoor ; 20°CDB Outdoor ; 7°CDB/6°CWB	7.5m

Conversion Formulae
kcal/h=kWx860 Btu/h=kWx3414 cfm=m³/minx35.3

230V, 50Hz

Models	Indoor Units		ATXS20CVMB(9)		ATXS25CVMB(9)	
	Outdoor Units		ARXH20CVMB9		ARXH25CVMB9	
			Cooling	Heating	Cooling	Heating
Capacity Rated (Min.~Max.)	kW		2.0 (1.3~2.6)	2.6 (1.3~4.0)	2.25 (1.3~3.0)	2.85 (1.3~4.5)
	Btu/h		6,800 (4,450~8,850)	8,850 (4,450~13,650)	7,650 (4,450~10,250)	9,700 (4,450~15,350)
	kcal/h		1,720 (1,120~2,240)	2,240 (1,120~3,440)	1,940 (1,120~2,580)	2,450 (1,120~3,870)
Moisture Removal	L/h		0.9	—	1.2	—
Running Current (Rated)	A		3.3	4.0	3.7	4.4
Power Consumption Rated (Min.~Max.)	W		620 (430~945)	760 (350~1,310)	700 (430~1,200)	835 (350~1,610)
Power Factor	%		81.7	82.6	82.3	82.5
COP (Rated)	W/W		3.23	3.42	3.21	3.41
Piping Connections	Liquid	mm	φ 6.4		φ 6.4	
	Gas	mm	φ 9.5		φ 9.5	
	Drain	mm	φ18.0		φ18.0	
Heat Insulation	Both Liquid and Gas Pipes					Both Liquid and Gas Pipes
Indoor Units		ATXS20CVMB(9)		ATXS25CVMB(9)		
Front Panel Color		White				White
Air Flow Rate	m³/min (cfm)	H	7.7 (272)	7.8 (275)	7.7 (272)	7.8 (275)
		M	5.9 (208)	6.5 (230)	5.9 (208)	6.5 (230)
		L	4.2 (148)	5.3 (187)	4.2 (148)	5.3 (187)
		SL	3.6 (127)	4.6 (162)	3.6 (127)	4.6 (162)
Fan	Type	Cross Flow Fan				Cross Flow Fan
	Motor Output	W	18		18	
	Speed	Steps	5 Steps, Silent and Auto		5 Steps, Silent and Auto	
Air Direction Control		Right, Left, Horizontal and Downward				Right, Left, Horizontal and Downward
Air Filter		Removable / Washable / Mildew Proof				Removable / Washable / Mildew Proof
Running Current (Rated)	A		0.18	0.18	0.18	0.18
Power Consumption (Rated)	W		40	40	40	40
Power Factor	%		96.6	96.6	96.6	96.6
Temperature Control		Microcomputer Control				Microcomputer Control
Dimensions (HxWxD)	mm	273x784x185		273x784x185		
Packaged Dimensions (WxDxH)	mm	834x325x258		834x325x258		
Weight	kg	7.5		7.5		
Gross Weight	kg	11		11		
Operation Sound	H/M/L/SL	dBA	38 / 32 / 25 / 22	38 / 33 / 28 / 25	38 / 32 / 25 / 22	38 / 33 / 28 / 25
Sound Power	H	dBA	56	56	56	56
Outdoor Units		ARXH20CVMB9		ARXH25CVMB9		
Casing Color		Ivory White				Ivory White
Compressor	Type	Hermetically Sealed Swing Type				Hermetically Sealed Swing Type
	Model	1YC23NXD#A				1YC23NXD#A
	Motor Output	W	600		600	
Refrigerant Oil	Type	FVC50K				FVC50K
	Charge	L	0.375		0.375	
Refrigerant	Type	R410A				R410A
	Charge	kg	0.79		0.79	
Air Flow Rate	m³/min (cfm)	H	29 (1,025)	25.5 (901)	29 (1,025)	25.5 (901)
		L	—	—	—	—
Fan	Type	Propeller				Propeller
	Motor Output	W	25		25	
Running Current (Rated)	A		3.12	3.82	3.52	4.22
Power Consumption (Rated)	W		580	720	660	795
Power Factor	%		80.8	81.9	81.5	81.9
Starting Current	A		4.0		4.4	
Dimensions (HxWxD)	mm	560x695x265		560x695x265		
Packaged Dimensions (WxDxH)	mm	824x337x599		824x337x599		
Weight	kg	31		31		
Gross Weight	kg	36		36		
Operation Sound	H/L	dBA	46 / —	47 / —	46 / —	47 / —
Sound Power	H	dBA	61	62	61	62
Drawing No.	C:3D044449				C:3D044450	

Notes:

- MAX. interunit piping length: 15m
- MAX. interunit height difference: 15m
- Amount of additional charge of refrigerant 20g/m for piping length exceeding 10m
- The data are based on the conditions shown in the table below.

Cooling	Heating	Piping Length
Indoor ; 27°CDB/19°CWB Outdoor ; 35°CDB/24°CWB	Indoor ; 20°CDB Outdoor ; 7°CDB/6°CWB	7.5m

Conversion Formulae

kcal/h=kWx860
Btu/h=kWx3414
cfm=m³/minx35.3

230V, 50Hz

Models	Indoor Units		ATXS35CVMB(9)	
	Outdoor Units		ARXH35CVMB9	
			Cooling	Heating
Capacity Rated (Min.~Max.)	kW		3.15 (1.4~3.8)	
	Btu/h		10,750 (4,750~12,950)	
	kcal/h		2,710 (1,200~3,270)	
Moisture Removal	L/h		1.7	
Running Current (Rated)	A		4.9	
Power Consumption Rated (Min.~Max.)	W		1,045 (460~1,425)	
Power Factor	%		92.7	
COP (Rated)	W/W		3.01	
Piping Connections	Liquid	mm	φ 6.4	
	Gas	mm	φ 9.5	
	Drain	mm	φ18.0	
Heat Insulation	Both Liquid and Gas Pipes			
Indoor Units		ATXS35CVMB(9)		
Front Panel Color		White		
Air Flow Rate	m³/min (cfm)	H	7.7 (272)	
		M	6.1 (215)	
		L	4.4 (155)	
		SL	3.8 (134)	
Fan	Type	Cross Flow Fan		
	Motor Output	W 18		
	Speed	Steps 5 Steps, Silent and Auto		
Air Direction Control		Right, Left, Horizontal and Downward		
Air Filter		Removable / Washable / Mildew Proof		
Running Current (Rated)	A		0.18	
Power Consumption (Rated)	W		40	
Power Factor	%		96.6	
Temperature Control		Microcomputer Control		
Dimensions (HxWxD)		mm 273x784x185		
Packaged Dimensions (WxDxH)		mm 834x325x258		
Weight		kg 7.5		
Gross Weight		kg 11		
Operation Sound	H/M/L/SL	dBA	39 / 33 / 26 / 23	
Sound Power	H	dBA	57	
Outdoor Units		ARXH35CVMB9		
Casing Color		Ivory White		
Compressor	Type	Hermetically Sealed Swing Type		
	Model	1YC23NXD#A		
	Motor Output	W 600		
Refrigerant Oil	Type	FVC50K		
	Charge	L 0.375		
Refrigerant	Type	R410A		
	Charge	kg 1.01		
Air Flow Rate	m³/min (cfm)	H	27.5 (972)	
		L	—	
Fan	Type	Propeller		
	Motor Output	W 25		
Running Current (Rated)	A		4.72	
Power Consumption (Rated)	W		1,005	
Power Factor	%		92.6	
Starting Current	A		4.9	
Dimensions (HxWxD)		mm 560x695x265		
Packaged Dimensions (WxDxH)		mm 824x337x599		
Weight		kg 33		
Gross Weight		kg 38		
Operation Sound	H/L	dBA	48 / —	
Sound Power	H	dBA	63	
Drawing No.		C:3D044451		

Notes:

- MAX. interunit piping length: 15m
- MAX. interunit height difference: 15m
- Amount of additional charge of refrigerant 20g/m for piping length exceeding 10m
- The data are based on the conditions shown in the table below.

Cooling	Heating	Piping Length
Indoor ; 27°CDB/19°CWB Outdoor ; 35°CDB/24°CWB	Indoor ; 20°CDB Outdoor ; 7°CDB/6°CWB	7.5m

Conversion Formulae
kcal/h=kWx860 Btu/h=kWx3414 cfm=m³/minx35.3

1.2.3 Non-Inverter Models

230V, 50Hz

Models	Indoor Units		FTYN20CVMB9		FTYN25CVMB9	
	Outdoor Units		RYN20CVMB9		RYN25CVMB9	
			Cooling	Heating	Cooling	Heating
Capacity Rated (Min.-Max.)	kW		2.0	2.6	2.25	2.85
	Btu/h		6,800	8,850	7,650	9,700
	kcal/h		1,720	2,240	1,940	2,450
Moisture Removal	L/h		0.9	—	1.2	—
Running Current (Rated)	A		3.3	4.0	3.7	4.4
Power Consumption Rated (Min.-Max.)	W		620	760	700	835
Power Factor	%		81.7	82.6	82.3	82.5
COP (Rated)	W/W		3.23	3.42	3.21	3.41
Piping Connections	Liquid	mm	φ 6.4		φ 6.4	
	Gas	mm	φ 9.5		φ 9.5	
	Drain	mm	φ 18.0		φ 18.0	
Heat Insulation			Both Liquid and Gas Pipes		Both Liquid and Gas Pipes	
Indoor Units		FTYN20CVMB9		FTYN25CVMB9		
Front Panel Color		White		White		
Air Flow Rate	m ³ /min (cfm)	H	7.7 (272)	7.8 (275)	7.7 (272)	7.8 (275)
		M	5.9 (208)	6.5 (230)	5.9 (208)	6.5 (230)
		L	4.2 (148)	5.3 (187)	4.2 (148)	5.3 (187)
		SL	—	—	—	—
Fan	Type	Cross Flow Fan		Cross Flow Fan		
	Motor Output	W	18		18	
	Speed	Steps	5 Steps and Auto		5 Steps and Auto	
Air Direction Control			Right, Left, Horizontal and Downward		Right, Left, Horizontal and Downward	
Air Filter			Removable / Washable / Mildew Proof		Removable / Washable / Mildew Proof	
Running Current (Rated)	A		0.18	0.18	0.18	0.18
Power Consumption (Rated)	W		40	40	40	40
Power Factor	%		96.6	96.6	96.6	96.6
Temperature Control			Microcomputer Control		Microcomputer Control	
Dimensions (HxWxD)	mm		273x784x185		273x784x185	
Packaged Dimensions (WxDxH)	mm		834x325x258		834x325x258	
Weight	kg		7.5		7.5	
Gross Weight	kg		11		11	
Operation Sound	H/M/L/SL	dBA	38 / 32 / 26 / —	38 / 33 / 28 / —	38 / 32 / 26 / —	38 / 33 / 28 / —
Sound Power	H	dBA	56	56	56	56
Outdoor Units		RYN20CVMB9		RYN25CVMB9		
Casing Color		Ivory White		Ivory White		
Compressor	Type	Hermetically Sealed Swing Type		Hermetically Sealed Swing Type		
	Model	1YC23NXD#A		1YC23NXD#A		
	Motor Output	W	600		600	
Refrigerant Oil	Type	FVC50K		FVC50K		
	Charge	L	0.375		0.375	
Refrigerant	Type	R410A		R410A		
	Charge	kg	0.79		0.79	
Air Flow Rate	m ³ /min (cfm)	H	29 (1,025)	25.5 (901)	29 (1,025)	25.5 (901)
		L	—	—	—	—
Fan	Type	Propeller		Propeller		
	Motor Output	W	25		25	
Running Current (Rated)	A		3.12	3.82	3.52	4.22
Power Consumption (Rated)	W		580	720	660	795
Power Factor	%		80.8	81.9	81.5	81.9
Starting Current	A		4.0		4.4	
Dimensions (HxWxD)	mm		560x695x265		560x695x265	
Packaged Dimensions (WxDxH)	mm		824x337x599		824x337x599	
Weight	kg		31		31	
Gross Weight	kg		36		36	
Operation Sound	H/L	dBA	46 / —	47 / —	46 / —	47 / —
Sound Power	H	dBA	61	62	61	62
Drawing No.			3D044452		3D044453	

Notes:

- MAX. interunit piping length: 15m
- MAX. interunit height difference: 15m
- Amount of additional charge of refrigerant 20g/m for piping length exceeding 10m
- The data are based on the conditions shown in the table below.

Cooling	Heating	Piping Length
Indoor ; 27°CDB/19°CWB Outdoor ; 35°CDB/24°CWB	Indoor ; 20°CDB Outdoor ; 7°CDB/6°CWB	7.5m

Conversion Formulae

kcal/h=kW×860
Btu/h=kW×3414
cfm=m³/min×35.3

Models	Indoor Units		FTYN35CVMB9	
	Outdoor Units		RYN35CVMB9	
			Cooling	Heating
Capacity Rated (Min.~Max.)	kW		3.15	3.6
	Btu/h		10,750	12,300
	kcal/h		2,710	3,100
Moisture Removal	L/h		1.7	—
Running Current (Rated)	A		4.9	4.9
Power Consumption Rated (Min.~Max.)	W		1,045	1,055
Power Factor	%		92.7	93.6
COP (Rated)	W/W		3.01	3.41
Piping Connections	Liquid	mm	φ 6.4	
	Gas	mm	φ 9.5	
	Drain	mm	φ18.0	
Heat Insulation	Both Liquid and Gas Pipes			
Indoor Units		FTYN35CVMB9		
Front Panel Color		White		
Air Flow Rate	m³/min (cfm)	H	7.7 (272)	8.1 (286)
		M	6.1 (215)	6.7 (237)
		L	4.4 (155)	5.3 (187)
		SL	—	—
Fan	Type	Cross Flow Fan		
	Motor Output	W		
	Speed	Steps		
Air Direction Control	Right, Left, Horizontal and Downward			
Air Filter	Removable / Washable / Mildew Proof			
Running Current (Rated)	A		0.18	0.18
Power Consumption (Rated)	W		40	40
Power Factor	%		96.6	96.6
Temperature Control	Microcomputer Control			
Dimensions (HxWxD)	mm		273x784x185	
Packaged Dimensions (WxDxH)	mm		834x325x258	
Weight	kg		7.5	
Gross Weight	kg		11	
Operation Sound	H/M/L/SL	dBA	39 / 33 / 26 / —	39 / 34 / 29 / —
Sound Power	H	dBA	57	57
Outdoor Units		RYN35CVMB9		
Casing Color		Ivory White		
Compressor	Type	Hermetically Sealed Swing Type		
	Model	1YC23NXD#A		
	Motor Output	W		
Refrigerant Oil	Type	FVC50K		
	Charge	L		
Refrigerant	Type	R410A		
	Charge	kg		
Air Flow Rate	m³/min (cfm)	H	27.5 (972)	23.5 (830)
		L	—	—
Fan	Type	Propeller		
	Motor Output	W		
Running Current (Rated)	A		4.72	4.72
Power Consumption (Rated)	W		1,005	1,015
Power Factor	%		92.6	93.5
Starting Current	A		4.9	
Dimensions (HxWxD)	mm		560x695x265	
Packaged Dimensions (WxDxH)	mm		824x337x599	
Weight	kg		33	
Gross Weight	kg		38	
Operation Sound	H/L	dBA	48 / —	48 / —
Sound Power	H	dBA	63	63
Drawing No.	3D044454			

Notes:

- MAX. interunit piping length: 15m
- MAX. interunit height difference: 15m
- Amount of additional charge of refrigerant 20g/m for piping length exceeding 10m
- The data are based on the conditions shown in the table below.

Cooling	Heating	Piping Length
Indoor ; 27°CDB/19°CWB Outdoor ; 35°CDB/24°CWB	Indoor ; 20°CDB Outdoor ; 7°CDB/6°CWB	7.5m

Conversion Formulae

kcal/h=kWx860
Btu/h=kWx3414
cfm=m³/minx35.3

Part 3

Printed Circuit Board

Connector Wiring Diagram

1. Printed Circuit Board Connector Wiring Diagram.....	24
1.1 Indoor Unit.....	24
1.2 Outdoor Unit / RK(X)S-C, ARK(X)S-C.....	26
1.3 Outdoor Unit / RK(X)H-C, ARK(X)H-C, R(Y)N-C	28

1. Printed Circuit Board Connector Wiring Diagram

1.1 Indoor Unit

Connectors

- | | |
|-------------|-----------------------------------------------|
| 1) S1 | Connector for fan motor |
| 2) S6 | Connector for swing motor (horizontal blades) |
| 3) S7 | Connector for fan motor (Hall IC) |
| 4) S21 | Connector for centralized control (HA) |
| 5) S26 | Connector for signal receiver PCB |
| 6) S27, S36 | Connector for control PCB |
| 7) S32 | Connector for heat exchanger thermistor |
| 8) S35 | Connector for INTELLIGENT EYE sensor PCB |



Note: Other designations

- | | |
|---------|--------------------------------------------------------|
| 1) V1 | Varistor |
| 2) JA | Address setting jumper |
| JB | Fan speed setting when compressor is OFF on thermostat |
| JC | Power failure recovery function (auto-restart) |
| | * Refer to page 205 for detail. |
| 3) SW7 | Forced operation ON / OFF switch |
| 4) LED1 | LED for operation (green) |
| 5) LED2 | LED for timer (yellow) |
| 6) LED3 | LED for HOME LEAVE operation (red) |
| 7) FU1 | Fuse (3.15A) |
| 8) RTH1 | Room temperature thermistor |

PCB Detail

PCB(1): Control PCB

PCB(2): Signal Receiver PCB

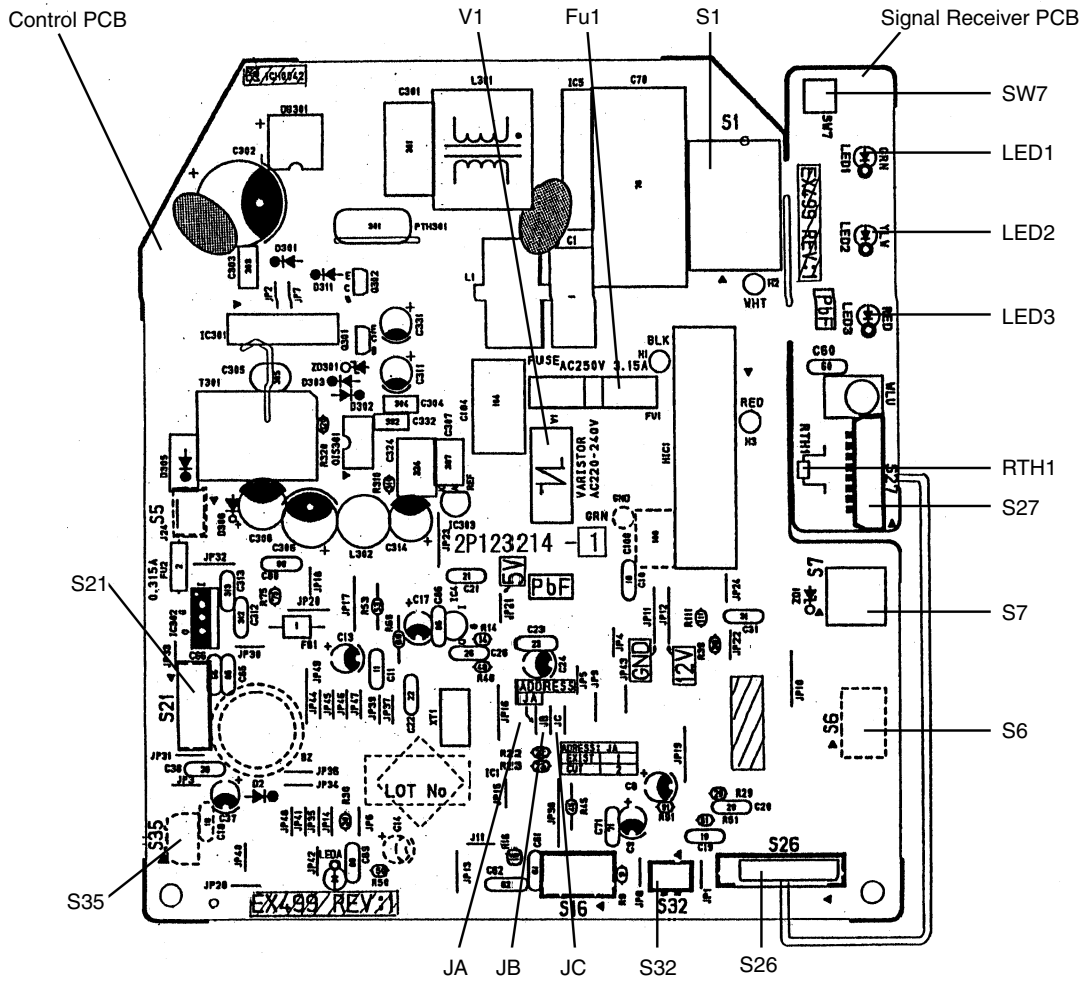

(R4011)

PCB(3): INTELLIGENT EYE sensor PCB

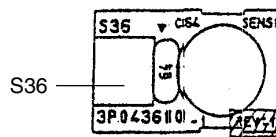

(R3321)

1.2 Outdoor Unit / RK(X)S-C, ARK(X)S-C

Connectors

- | | |
|-----------------------|----------------------------------------------------------------------------|
| 1) S10 | Connector for filter PCB |
| 2) S11 | Connector for control PCB |
| 3) S20 | Connector for electronic expansion valve coil |
| 4) S30 | Connector for compressor motor |
| 5) S40 | Connector for overload protector |
| 6) S70 | Connector for fan motor |
| 7) S80 | Connector for four way valve coil |
| 8) S90 | Connector for thermistors
(outdoor air, heat exchanger, discharge pipe) |
| 9) HC3, HC4, HL3, HN3 | Connector for filter PCB |



Note: Other designations

- | | |
|---------------|----------------------------------------------------------|
| 1) FU1, FU2 | Fuse (3.15A) |
| 2) FU3 | Fuse (20A) |
| 3) LEDA | Service monitor LED |
| 4) V1, V2, V3 | Varistor |
| 5) J8 | Facility setting jumper
*Refer to page 57 for detail. |

PCB Detail

PCB(1): Control PCB (outdoor unit)

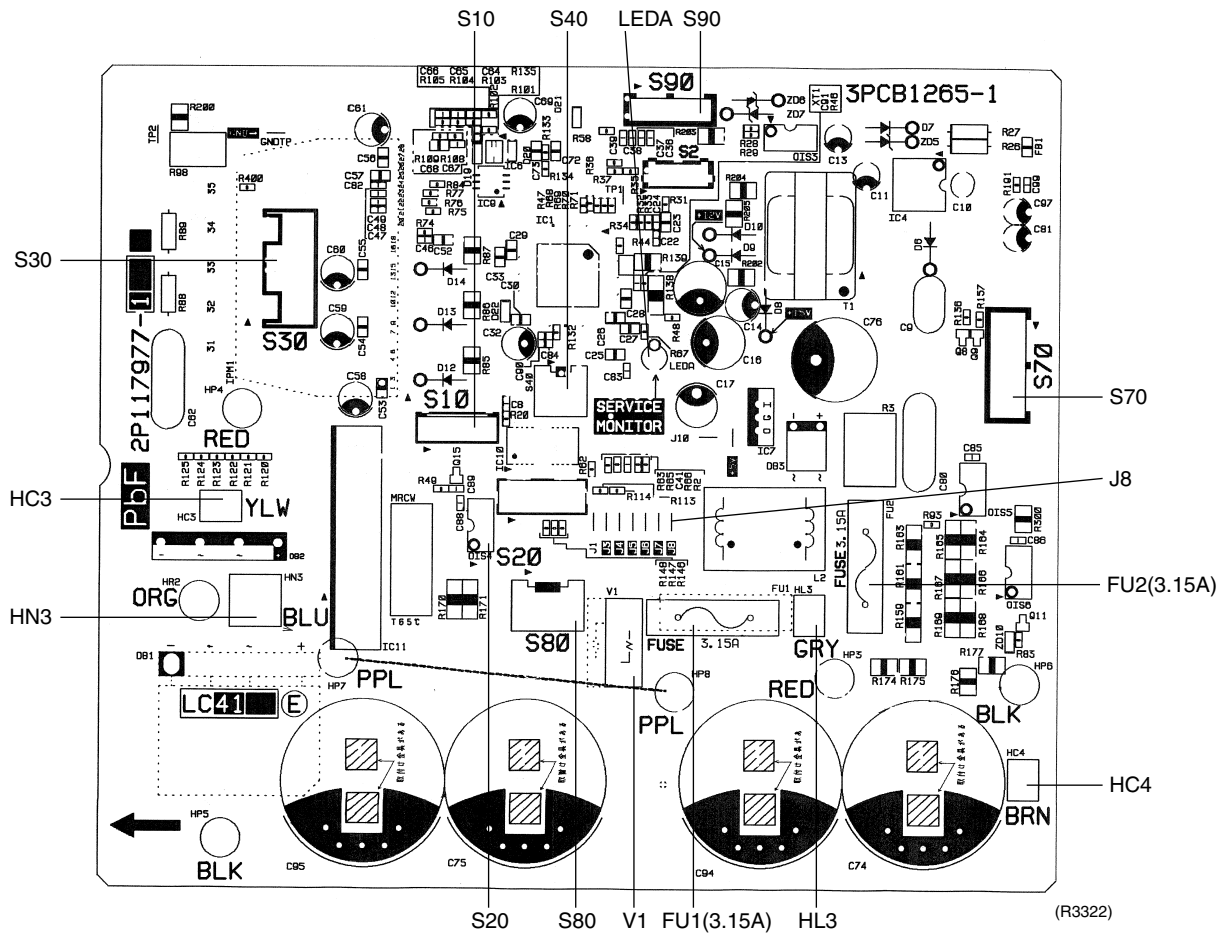

PCB(2): Filter PCB

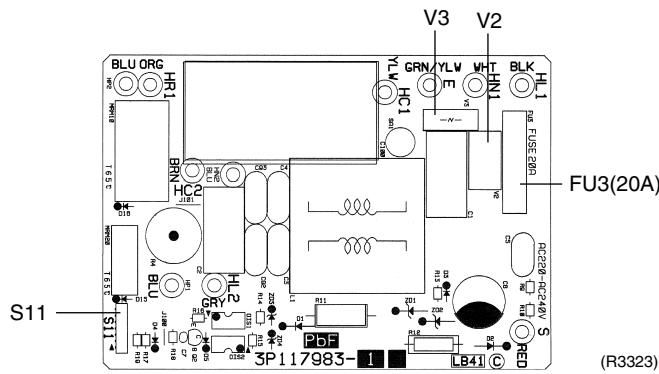

1.3 Outdoor Unit / RK(X)H-C, ARK(X)H-C, R(Y)N-C

Connectors

- 1) **S20** Connector for electronic expansion valve
- 2) **S70** Connector for fan motor
- 3) **S80** Connector for four way valve
- 4) **S90** Connector for thermistors (outdoor air, heat exchanger, discharge pipe)



Note: Other designations

- 1) **FU1** Fuse (3.15A)
- 2) **FU3** Fuse (20A)
- 3) **LEDA** Service monitor LED
- 4) **V1, V2, V3** Varistor

PCB Detail

Control PCB (outdoor unit)

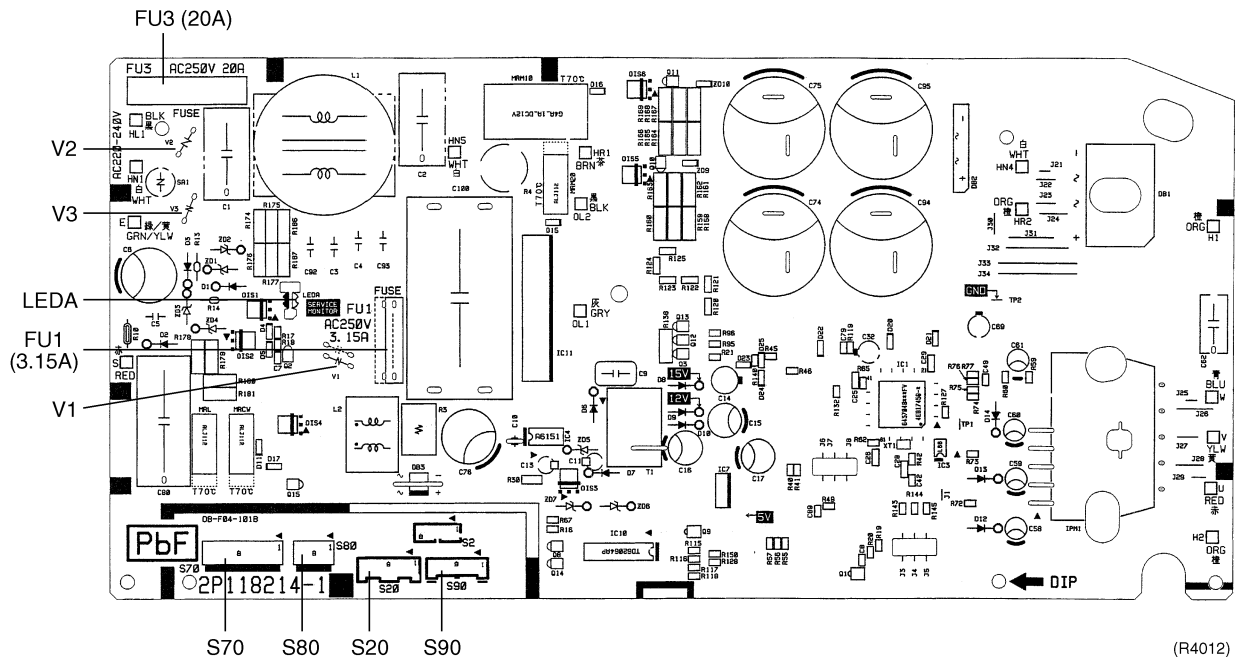

Part 4

Function and Control

1. Main Functions.....	30
1.1 Frequency Principle.....	30
1.2 Power-Airflow Dual Flaps, Wide-Angle Louvres and Auto-Swing	32
1.3 Fan Speed Control for Indoor Units.....	33
1.4 Programme Dry Function	34
1.5 Automatic Operation.....	35
1.6 NIGHT SET Mode	36
1.7 INTELLIGENT EYE	37
1.8 HOME LEAVE Operation	39
1.9 Inverter Powerful Operation	40
1.10 Other Functions.....	41
2. Function of Main Structural Parts	42
2.1 Function of Thermistor	42
3. Control Specification	44
3.1 Mode Hierarchy	44
3.2 Frequency Control.....	45
3.3 Controls at Mode Changing / Start-up.....	47
3.4 Discharge Pipe Control	48
3.5 Input Current Control.....	49
3.6 Freeze-up Protection Control	49
3.7 Heating Peak-cut Control	50
3.8 Fan Control.....	50
3.9 Liquid Compression Protection Function 2.....	50
3.10 Defrost Control	51
3.11 Electronic Expansion Valve Control	52
3.12 Malfunctions	55
3.13 Forced Operation Mode	56
3.14 Additional Function.....	56
3.15 Facility Setting Jumper (cooling at low outdoor temperature)	57

1. Main Functions

i Note: See the list of functions for the functions applicable to different models.

1.1 Frequency Principle

Main Control Parameters

The compressor is frequency-controlled during normal operation. The target frequency is set by the following 2 parameters coming from the operating indoor unit:

- The load condition of the operating indoor unit
- The difference between the room temperature and the set temperature

Additional Control Parameters

The target frequency is adapted by additional parameters in the following cases:

- Frequency restrictions
- Initial settings
- Forced cooling operation

Inverter Principle

To regulate the capacity, a frequency control is needed. The inverter makes it possible to vary the rotation speed of the compressor. The following table explains the conversion principle:

Phase	Description
1	The supplied AC power source is converted into the DC power source for the present.
2	The DC power source is reconverted into the three phase AC power source with variable frequency. <ul style="list-style-type: none"> ■ When the frequency increases, the rotation speed of the compressor increases resulting in an increased refrigerant circulation. This leads to a higher amount of the heat exchange per unit. ■ When the frequency decreases, the rotation speed of the compressor decreases resulting in a decreased refrigerant circulation. This leads to a lower amount of the heat exchange per unit.

Drawing of Inverter

The following drawing shows a schematic view of the inverter principle:

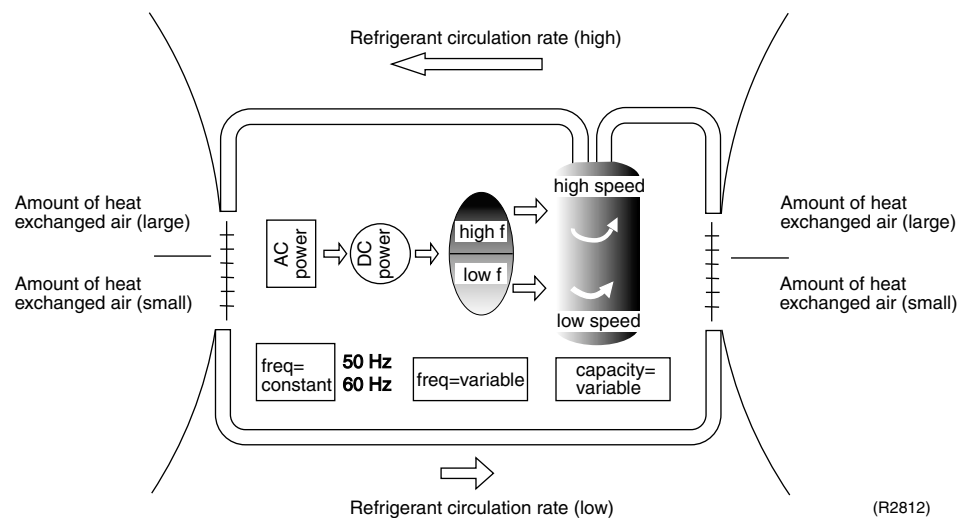

Inverter Features

The inverter provides the following features:

- The regulating capacity can be changed according to the changes in the outdoor air temperature and cooling / heating load.
- Quick heating and quick cooling
The compressor rotational speed is increased when starting the heating (or cooling). This enables a quick set temperature.

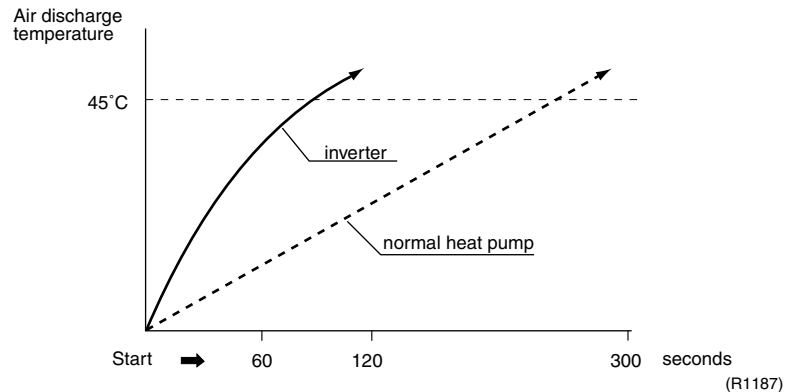

- Even during extreme cold weather, the high capacity is achieved. It is maintained even when the outdoor air temperature is 2°C.
- Comfortable air conditioning
A detailed adjustment is integrated to ensure a fixed room temperature. It is possible to air condition with a small room temperature variation.
- Energy saving heating and cooling
Once the set temperature is reached, the energy saving operation enables to maintain the room temperature at low power.

Frequency Limits

The following table shows the functions that define the minimum and maximum frequency:

Frequency limits	Limited during the activation of following functions
Low	<ul style="list-style-type: none"> ■ Four way valve operation compensation. Refer to page 47.
High	<ul style="list-style-type: none"> ■ Input current control. Refer to page 49. ■ Compressor protection function. Refer to page 48. ■ Heating peak-cut control. Refer to page 50. ■ Freeze-up protection control. Refer to page 49. ■ Defrost control. Refer to page 51.

Forced Cooling Operation

For more information, refer to "Forced operation mode" on page 56.

1.2 Power-Airflow Dual Flaps, Wide-Angle Louvres and Auto-Swing

Power-Airflow Dual Flaps

The large flaps send a large volume of air downwards to the floor. The flap provides an optimum control area in cooling, heating and dry mode.

Heating Mode

During heating mode, the large flap enables direct warm air straight downwards. The flap presses the warm air above the floor to reach the entire room.

Cooling Mode

During cooling mode, the flap retracts into the indoor unit. Then, cool air can be blown far and pervaded all over the room.

Wide-Angle Louvres

The louvres, made of elastic synthetic resin, provide a wide range of airflow that guarantees a comfortable air distribution.

Auto-Swing

The following table explains the auto swing process for heating, cooling, dry and fan :

Vertical Swing (up and down)		Horizontal Swing (right and left: manual)
Cooling / Dry / Fan	Heating	Heating, Cooling
<p>(R2946)</p>	<p>(R4013)</p>	<p>(R2817)</p>

1.3 Fan Speed Control for Indoor Units

Control Mode

The airflow rate can be automatically controlled depending on the difference between the set temperature and the room temperature. This is done through phase control and Hall IC control.



For more information about Hall IC, refer to trouble shooting for fan motor on page 99.

Phase Steps

Phase control and fan speed control contains 9 steps: LLL, LL, SL, L, ML, M, MH, H and HH.

Step	Cooling	Heating	Dry mode
LLL (Heating thermostat OFF)	 (R4085)	 (R4085)	25 · 35kW class : 500 - 860 rpm (During powerful operation : 850 - 910 rpm)
LL (Cooling thermostat OFF)			
SL (Silent)			
L			
ML			
M			
MH			
H			
HH (Powerful)			

= Within this range the airflow rate is automatically controlled when the FAN setting button is set to automatic.



Note:

1. During powerful operation, fan operate H tap + 50 - 90 rpm.
2. Fan stops during defrost operation.

Automatic Air Flow Control for Heating

The following drawing explains the principle for fan speed control for heating:

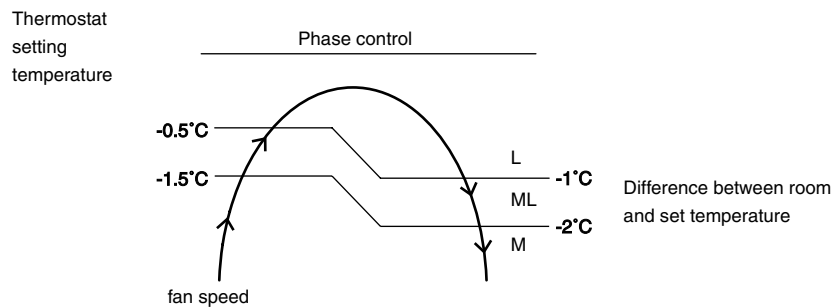

Automatic Air Flow Control for Cooling

The following drawing explains the principle of fan speed control for cooling:

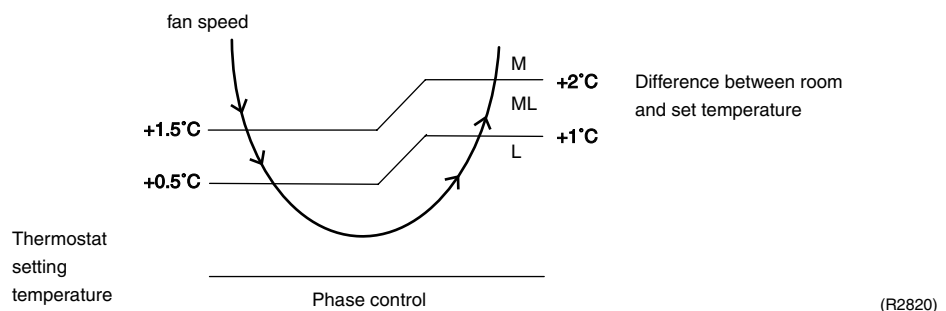

1.4 Programme Dry Function

Programme dry function removes humidity while preventing the room temperature from lowering.

Since the microcomputer controls both the temperature and air flow volume, the temperature adjustment and fan adjustment buttons are inoperable in this mode.

In Case of Inverter Units

The microcomputer automatically sets the temperature and fan settings. The difference between the room temperature at startup and the temperature set by the microcomputer is divided into two zones. Then, the unit operates in the dry mode with an appropriate capacity for each zone to maintain the temperature and humidity at a comfortable level.

Room temperature at startup	Temperature (ON point) at which operation starts	Frequency switching point	Temperature difference for operation stop
24°C	Room temperature at startup	0.5°C	1.5°C
18°C	18°C		1.0°C
17°C		—	

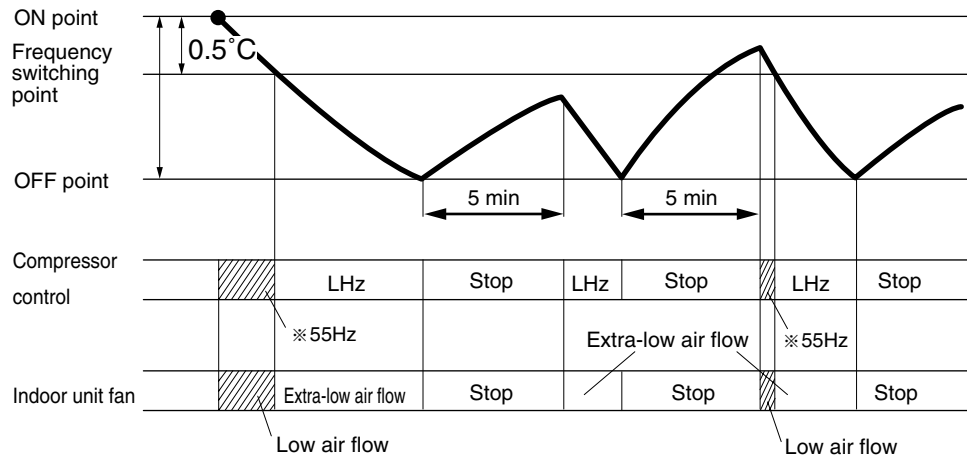

LHz indicates low frequency. Item marked with * varies depending on models.

(R1359)

1.5 Automatic Operation

Automatic Cooling / Heating Function (Heat Pump Only)

When the AUTO mode is selected with the remote controller, the microcomputer automatically determines the operation mode from cooling and heating according to the room temperature and setting temperature at the time of the operation startup, and automatically operates in that mode.

The unit automatically switches the operation mode to cooling or heating to maintain the room temperature at the main unit setting temperature.

Detailed Explanation of the Function

1. Remote controller setting temperature is set as automatic cooling / heating setting temperature (18 to 30°C).
2. Main unit setting temperature equals remote controller setting temperature plus correction value (correction value / cooling: 0 deg, heating: 2 deg.).
3. Operation ON / OFF point and mode switching point are as follows.
 - ① Heating → Cooling switching point:
Room temperature \geq Main unit setting temperature +2.5 deg.
 - ② Cooling → Heating switching point:
Room temperature $<$ Main unit setting temperature -2.5 deg.
 - ③ Thermostat ON / OFF point is the same as the ON / OFF point of cooling or heating operation.
4. During initial operation
 Room temperature \geq Remote controller setting temperature: Cooling operation
 Room temperature $<$ Remote controller setting temperature: Heating operation

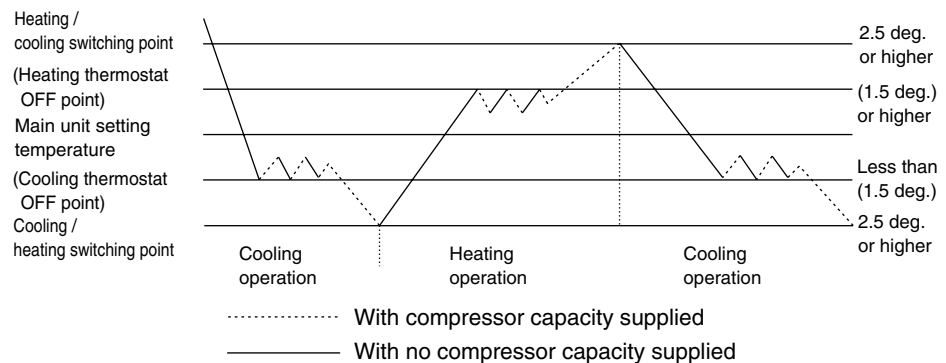

(R1360)

1.6 NIGHT SET Mode

When the OFF timer is set, the NIGHT SET circuit automatically activates. The NIGHT SET circuit maintains the airflow setting made by users.

The NIGHT SET Circuit

The NIGHT SET circuit continues heating or cooling the room at the set temperature for the first one hour, then automatically lowers the temperature setting slightly in the case of cooling, or raises it slightly in the case of heating, for economical operations. This prevents excessive heating in winter and excessive cooling in summer to ensure comfortable sleeping conditions, and also conserves electricity.

Cooling Operation

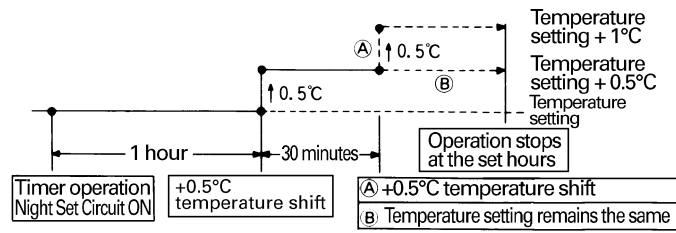

- Ⓐ : ● When outside temperature is normal and room temperature is at set temperature.
- Ⓑ : ● When outside temperature is high (27°C or higher).

(R1361)

Heating Operation

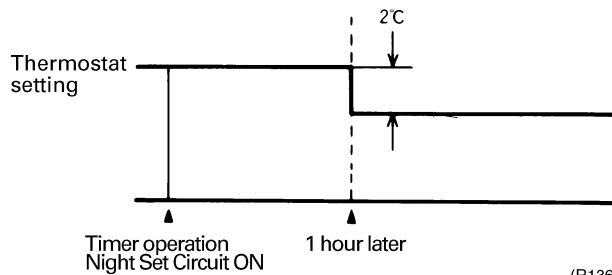

(R1362)

1.7 INTELLIGENT EYE

This is the function that detects existence of humans in the room by a human motion sensor (INTELLIGENT EYE) and reduces the capacity when there is no human in the room in order to save electricity.

Processing

1. Detection method by INTELLIGENT EYE

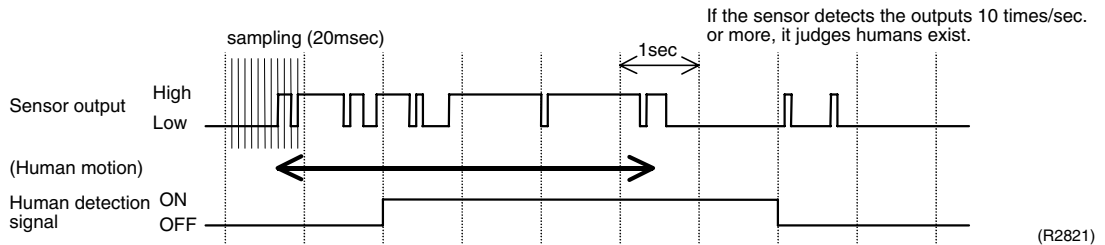

- This sensor detects human motion by receiving infrared rays and displays the pulse wave output.
- A microcomputer in an indoor unit carries out a sampling every 20 msec. and if it detects 10 cycles of the wave in one second in total (corresponding to $20\text{msec.} \times 10 = 100\text{msec.}$), it judges human is in the room as the motion signal is ON.

2. The motions (for example: in cooling)

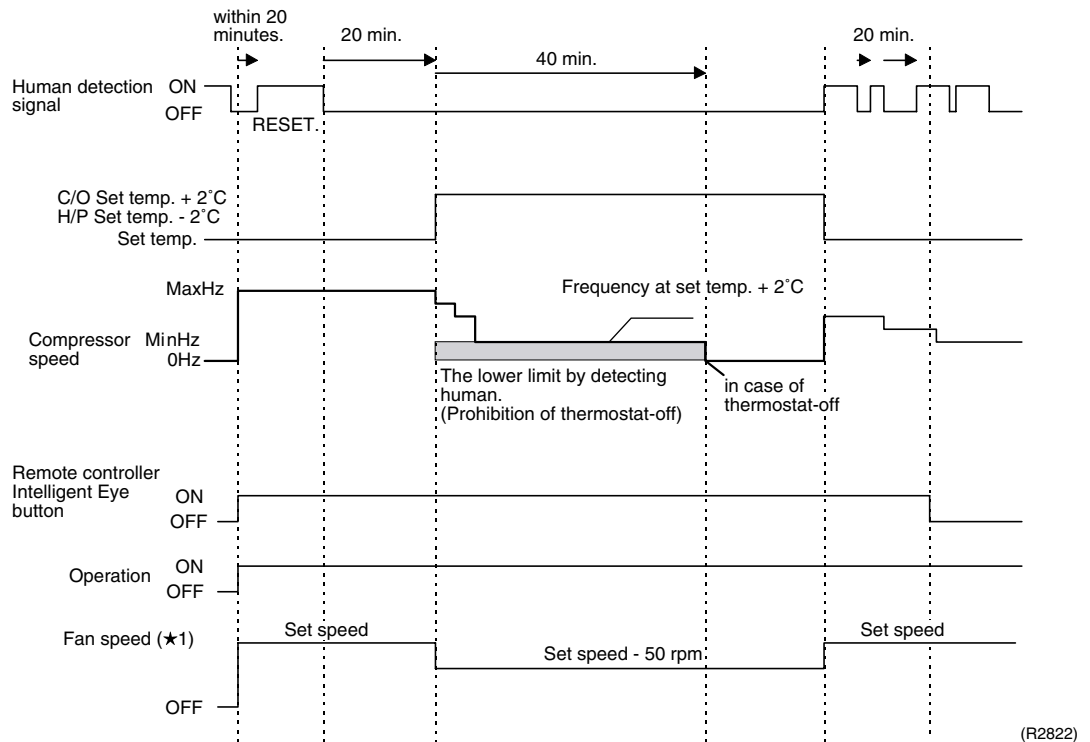

- When a microcomputer doesn't have a signal from the sensor in 20 minutes, it judges that nobody is in the room and operates the unit in temperature sifted 2°C from the set temperature. (COOL : 2°C higher, DRY: 1°C higher, AUTO : according to the operation mode at that time.)
- ★1 In case of FAN mode, the fan speed reduces by 50 rpm.

- Since the set temperature is shifted by 2°C higher for 40 minutes, compressor speed becomes low and can realize energy saving operation. But as thermostat is prone to be off by the fact that the set temperature has been shifted, the thermostat-off action is prohibited in 40 minutes so as to prevent this phenomena.
After this 40 minutes, the prohibition of the thermostat-off is cancelled and it can realize the conditions to conduct thermostat-off depending on the room temperature. In or after this forty minutes, if the sensor detects human motion detection signal, it let the set temperature and the fan speed return to the original set point, keeping a normal operation.

Others

- The dry operation can't command the setting temperature with a remote controller, but internally the set temperature is shifted by 1°C.

1.8 HOME LEAVE Operation

Outline

In order to respond to the customer's need for immediate heating and cooling of the room after returning home or for house care, a measure to switch the temperature and air volume from that for normal time over to outing time by one touch is provided. (This function responds also to the need for keeping up with weak cooling or heating.)

This time, we seek for simplicity of operation by providing the special temperature and air volume control for outing to be set by the exclusive button.

Detail of the Control

1. Start of Function

The function starts when the [HOME LEAVE] button is pressed in cooling mode or heating mode (including stopping and powerful operation). If this button is pressed while the operation is stopped, the function becomes effective when the operation is started. If this button is pressed in powerful operation, the powerful operation is reset and this function becomes effective.

- The [HOME LEAVE] button is ineffective in dry mode and fan mode.

2. Details of Function

A mark representing [HOME LEAVE] is indicated on the liquid crystal display of the remote controller. The indoor unit is operated according to the set temperature and air volume for HOME LEAVE which were pre-set in the memory of the remote controller.

The LED (Red) of indoor unit representing [HOME LEAVE] lights up. (It goes out when the operation is stopped.)

3. End of Function

The function ends when the [HOME LEAVE] button is pressed again during [HOME LEAVE] operation or when the powerful operation button is pressed.

Scene <cooling>



Scene <Heating>

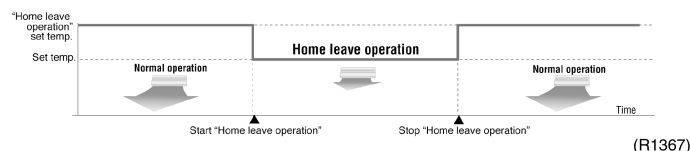
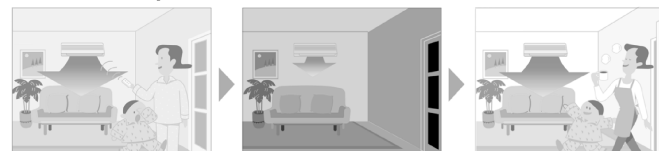

Others

The set temperature and set air volume are memorized in the remote controller. When the remote controller is reset due to replacement of battery, it is necessary to set the temperature and air volume again for [HOME LEAVE].

1.9 Inverter Powerful Operation

Outline

In order to exploit the cooling and heating capacity to full extent, operate the air conditioner by increasing the indoor fan rotating speed and the compressor frequency.

Details of the Control

When POWERFUL button is pushed in each operation mode, the fan speed / setting temperature will be converted to the following states in a period of twenty minutes.

Operation mode	Fan speed	Target set temperature
COOL	H tap + 90 rpm	18°C
DRY	Dry rotating speed + 50 rpm	Normally targeted temperature in dry operation; Approx. -2°C
HEAT	H tap + 90 rpm	30°C
FAN	H tap + 90 rpm	—
AUTO	Same as cooling / heating in Powerful operation	The target is kept unchanged

Ex.) : Powerful operation in cooling mode.

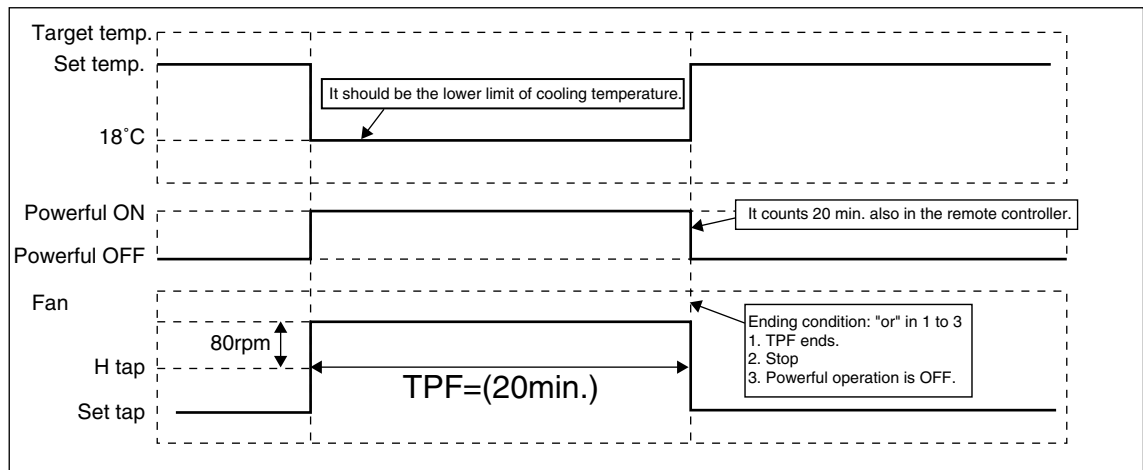

(R2823)

1.10 Other Functions

1.10.1 Hot Start Function

Heat Pump Only

In order to prevent the cold air blast that normally comes when heating is started, the temperature of the heat exchanger of the indoor unit is detected, and either the air flow is stopped or is made very weak thereby carrying out comfortable heating of the room.

*The cold air blast is also prevented using a similar control when the defrosting operation is started or when the thermostat gets turned ON.

1.10.2 Signal Receiving Sign

When the indoor unit receives a signal from the remote controller, the unit emits a signal receiving sound.

1.10.3 ON/OFF Button on Indoor Unit

An ON/OFF switch is provided on the front panel of the unit. Use this switch when the remote controller is missing or if its battery has run out.

Every press of the switch changes from Operation to Stop or from Stop to Operation

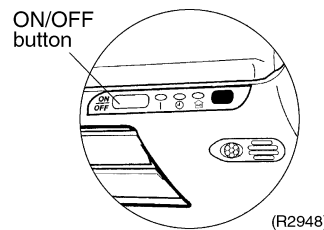

- Push this button once to start operation. Push once again to stop it.
- This button is useful when the remote controller is missing.
- The operation mode refers to the following table.

	Mode	Temperature setting	Air flow rate
Cooling Only	COOL	22°C	AUTO
Heat Pump	AUTO	25°C	AUTO

- In the case of multi system operation, there are times when the unit does not activate with this button.

1.10.4 Air Purifying Filter with Photocatalytic Deodorizing Function

This filter incorporates the benefits the Air Purifying Filter and Photocatalytic Deodorizing Filter in a single unit. Combining the two filters in this way increases the active surface area of the new filter. This larger surface area allows the filter to effectively trap microscopic particles, decompose odours and deactivate bacteria and viruses even for the high volume of air required to air-condition large living rooms. The filter can be used for approximately 3 years if periodic maintenance is performed.

1.10.5 Mold Proof Air Filter

The air filter net is impregnated with a safe, odourless mould preventative to make the filter virtually immune to mould.

1.10.6 Self-Diagnosis Digital Display

The microcomputer continuously monitors main operating conditions of the indoor unit, outdoor unit and the entire system. When an abnormality occur, the LCD remote controller displays error code. These indications allow prompt maintenance operations.

1.10.7 Auto-restart Function

Even if a power failure (including one for just a moment) occurs during the operation, the operation restarts in the condition before power failure automatically when power is restored. (Note) It takes 3 minutes to restart the operation because the 3-minutes standby function is activated.

2. Function of Main Structural Parts

2.1 Function of Thermistor

2.1.1 Heat Pump Model

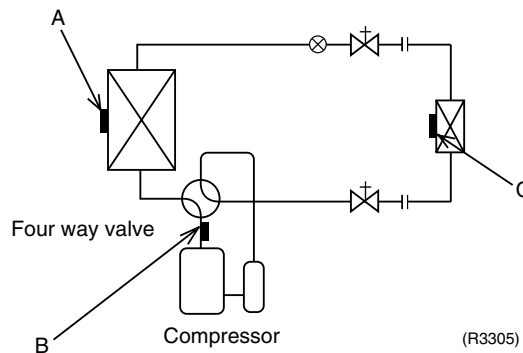

A Outdoor Heat Exchanger Thermistor (DCB)

1. The outdoor heat exchanger thermistor is used for controlling target discharge temperature. Set a target discharge temperature depending on the outdoor and indoor heat exchanger temperature. Control the electronic expansion valve opening so that the target discharge temperature can be obtained.
2. The outdoor heat exchanger thermistor is used for detecting the discharge thermistor disconnected when cooling. When the temperature of the discharge piping is lower than the temperature of outdoor heat exchanger, a disconnected discharge thermistor can be detected.
3. The outdoor heat exchanger thermistor is used for high pressure protection during cooling operation.

B Discharge Pipe Thermistor (DOT)

1. The discharge pipe thermistor is used to control the discharge pipe. If the temperature of discharge pipe (used in place of the inner temperature of the compressor) rises abnormally, the operating frequency drops or the operation must be halted.
2. The discharge pipe thermistor is used for detecting the discharge thermistor disconnected.

C Indoor Heat Exchanger Thermistor (DCN)

1. The indoor heat exchanger thermistor is used for controlling target discharge pipe temperature. Set a target discharge pipe temperature according to the outdoor and indoor heat exchanger temperature. Control the electronic expansion valve so that the target discharge pipe temperature can be obtained.
2. The indoor heat exchanger thermistor is used to prevent freezing. During the cooling operation, if the temperature drops abnormally, the operating frequency becomes lower, then the operation must be halted.
3. The indoor heat exchanger thermistor is used for anti-icing control. During the cooling operation, if the heat exchanger temperature in the room where operation is halted becomes -1°C , it is assumed as icing.
4. During heating: the indoor heat exchanger thermistor is used for detecting the discharge pipe thermistor disconnected. When the discharge pipe temperature become lower than an indoor heat exchanger temperature, a disconnected discharge pipe thermistor can be detected.

2.1.2 Cooling Only Model

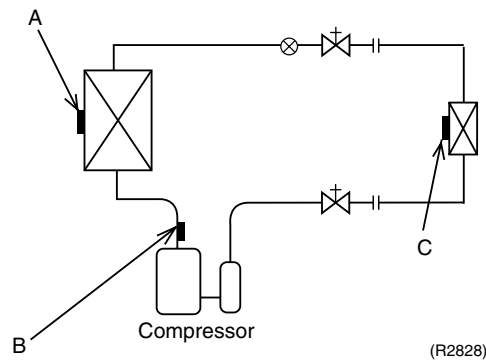

A Outdoor Heat Exchanger Thermistor (DCB)

1. The outdoor heat exchanger thermistor is used for controlling target discharge temperature. Set a target discharge temperature depending on the outdoor and indoor heat exchanger temperature. Control the electronic expansion valve opening so that the target discharge temperature can be obtained.
2. When cooling: an outdoor heat exchanger thermistor is used for detecting the discharge thermistor disconnected. When the temperature of the discharge piping is lower than the temperature of outdoor heat exchanger, a disconnected discharge thermistor can be detected.
3. The outdoor heat exchanger thermistor is used for high pressure protection during cooling operation.

B Discharge Pipe Thermistor (DOT)

1. The discharge pipe thermistor is used to control the discharge pipe. If the temperature of discharge pipe (used in place of the inner temperature of the compressor) rises abnormally, the operating frequency drops or the operation must be halted.
2. The discharge pipe thermistor is used for detecting the discharge thermistor disconnected.

C Indoor Heat Exchanger Thermistor (DCN)

1. The indoor heat exchanger thermistor is used for controlling target discharge pipe temperature. Set a target discharge pipe temperature according to the outdoor and indoor heat exchanger temperature. Control the electronic expansion valve opening so that the target discharge pipe temperature can be obtained.
2. The indoor heat exchanger thermistor is used to prevent freezing. During the cooling operation, if the temperature drops abnormally, the operating frequency becomes lower, then the operation must be halted.
3. The indoor heat exchanger thermistor is used for anti-icing control. During the cooling operation, if the heat exchanger temperature in the room where operation is halted becomes -1°C , it is assumed as icing.

3. Control Specification

3.1 Mode Hierarchy

Outline

There are two modes; the mode selected in user's place (normal air conditioning mode) and forced operation mode for installation and providing service.

Detail

1. For heat pump model

There are following modes; stop, cooling (includes drying), heating (include defrosting)

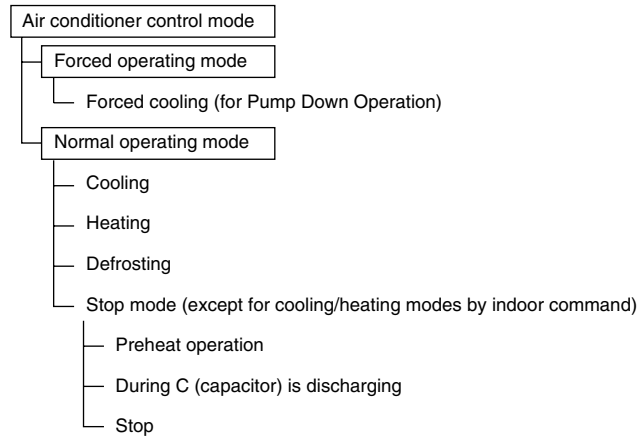

(R2829)

2. For cooling only model

There are following models; stop and cooling (including drying).

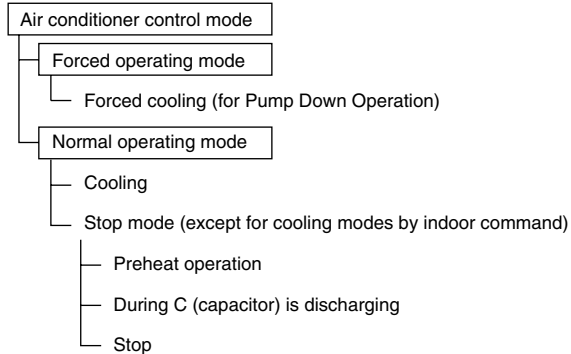

(R2830)



Note: Unless specified otherwise, an indoor dry operation command must be regarded as cooling operation.

3.2 Frequency Control

Outline

Frequency will be determined according to the difference between room and set temperature. The function is explained as follows.

1. How to determine frequency.
2. Frequency command from an indoor unit. (The difference between a room temperature and the temperature set by the remote controller.)
3. Frequency command from an indoor unit.
4. Frequency initial setting.
5. PI control.

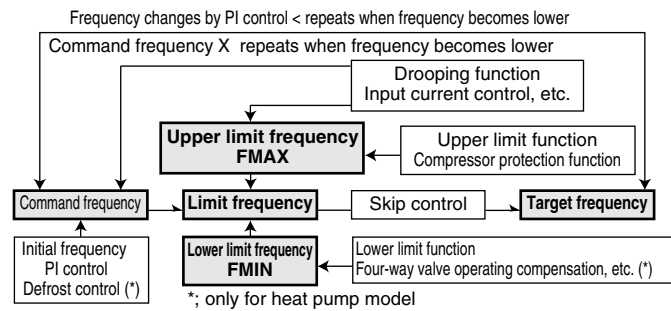

(R2831)

Detail

How to Determine Frequency

The compressor's frequency will finally be determined by taking the following steps.

For Heat Pump Model

1. Determine command frequency
 - Command frequency will be determined in the following order of priority.
 - 1.1 Limiting frequency by drooping function
 - Input current, discharge pipes, peak cutting, freeze-up protection, dew prevention, fin thermistor temperature.
 - 1.2 Limiting defrost control time
 - 1.3 Forced cooling
 - 1.4 Indoor frequency command
2. Determine upper limit frequency
 - Set a minimum value as an upper limit frequency among the frequency upper limits of the following functions:
Compressor protection, input current, discharge pipes, peak cutting, freeze-up protection, defrost.
3. Determine lower limit frequency
 - Set a maximum value as an lower limit frequency among the frequency lower limits of the following functions:
Four way valve operating compensation, draft prevention, pressure difference upkeep.
4. Determine prohibited frequency
 - There is a certain prohibited frequency such as a power supply frequency.

For Cooling Only Model

1. Determine command frequency
 - Command frequency will be determined in the following order of priority.
 - 1.1 Limiting frequency by drooping function
Input current, discharge pipes, freeze-up protection, dew prevention, fin thermistor temperature.
 - 1.2 Indoor frequency command
2. Determine upper limit frequency
 - Set a minimum value as an upper limit frequency among the frequency upper limits of the following functions:
Compressor protection, input current, discharge pipes, freeze-up protection, dew prevention, fin thermistor temperature.

3. Determine lower limit frequency
 - Set a maximum value as an lower limit frequency among the frequency lower limits of the following functions:
Pressure difference upkeep.
4. Determine prohibited frequency
 - There is a certain prohibited frequency such as a power supply frequency.

Indoor Frequency Command (ΔD signal)

The difference between a room temperature and the temperature set by the remote controller will be taken as the " ΔD signal" and is used for frequency command.

Temperature difference	ΔD signal	Temperature difference	ΔD signal	Temperature difference	ΔD signal	Temperature difference	ΔD signal
0	*Th OFF	2.0	4	4.0	8	6.0	C
0.5	1	2.5	5	4.5	9	6.5	D
1.0	2	3.0	6	5.0	A	7.0	E
1.5	3	3.5	7	5.5	B	7.5	F

*Th OFF = Thermostat OFF

Frequency Initial Setting

■ Outline

When starting the compressor, or when conditions are varied due to the change of the room, the frequency must be initialized according to the ΔD value of the indoor unit and the Q value of the indoor unit.

Q value: Indoor unit output determined from indoor unit volume, air flow rate and other factors.

PI Control (Determine Frequency Up / Down by ΔD Signal)

1. P control

Calculate ΔD value in each sampling time (20 seconds), and adjust the frequency according to its difference from the frequency previously calculated.
2. I control

If the operating frequency is not change more than a certain fixed time, adjust the frequency up and down according to the ΔD value, obtaining the fixed ΔD value.
When the ΔD value is small...lower the frequency.
When the ΔD value is large...increase the frequency.
3. Frequency management when other controls are functioning
 - When frequency is drooping;
Frequency management is carried out only when the frequency droops.
 - For limiting lower limit
Frequency management is carried out only when the frequency rises.
4. Upper and lower limit of frequency by PI control

The frequency upper and lower limits are set depending on indoor unit.
When low noise commands come from the indoor unit or when outdoor unit low noise or quiet commands come from indoor unit, the upper limit frequency must be lowered than the usual setting.

3.3 Controls at Mode Changing / Start-up

3.3.1 Preheating Operation

Outline	Operate the inverter in the open phase operation with the conditions including the preheating command (only for heat pump model) from the discharge pipe temperature.
----------------	-----------------------------------------------------------------------------------------------------------------------------------------------------------------------

Detail	<p>Preheating ON Condition</p> <ul style="list-style-type: none"> ■ When the discharge pipe temperature is below 10°C, inverter in open phase operation starts. <p>OFF Condition</p> <ul style="list-style-type: none"> ■ When the discharge pipe temperature is higher than 12°C, inverter in open phase operation stops.
---------------	------------------------------------------------------------------------------------------------------------------------------------------------------------------------------------------------------------------------------------------------------------------------------------------------------------------------------------------------------------------------

3.3.2 Four Way Valve Switching

Outline of Heating Operation	<p>Heat Pump Only</p> <p>During the heating operation current must be conducted and during cooling and defrosting current must not be conducted. In order to eliminate the switching sound (as the four way valve coil switches from ON to OFF) when the heating is stopped, the delay switch of the four way valve must be carried out after the operation stopped.</p>
-------------------------------------	---------------------------------------------------------------------------------------------------------------------------------------------------------------------------------------------------------------------------------------------------------------------------------------------------------------------------------------------------------------------------------

Detail	<p>The OFF delay of four way valve Energize the coil for 160 sec after unit operation is stopped.</p>
---------------	-----------------------------------------------------------------------------------------------------------

3.3.3 Four Way Valve Operation Compensation

Outline	<p>Heat Pump Only</p> <p>At the beginning of the operation as the four way valve is switched, acquire the differential pressure required for activating the four way valve by having output the operating frequency, which is more than a certain fixed frequency, for a certain fixed time.</p>
----------------	---------------------------------------------------------------------------------------------------------------------------------------------------------------------------------------------------------------------------------------------------------------------------------------------------------

Detail	<p>Starting Conditions</p> <ol style="list-style-type: none"> 1. When starting compressor for heating. 2. When the operating mode changes to cooling from heating. 3. When starting compressor for rushing defrosting or resetting. 4. When starting compressor for the first time after the reset with the power is ON. 5. When starting compressor for heating next to the suspension of defrosting. 6. When starting compressor next to the fault of switching over cooling / heating. <p>Set the lower limit frequency to 68 (model by model) Hz for 45 seconds (50 seconds for (A)RK(X)H, R(Y)N models) with any conditions 1 through 4 above.</p>
---------------	----------------------------------------------------------------------------------------------------------------------------------------------------------------------------------------------------------------------------------------------------------------------------------------------------------------------------------------------------------------------------------------------------------------------------------------------------------------------------------------------------------------------------------------------------------------------------------------------------------------------------------------------------------------------------------------------------------------------------

3.3.4 3-minutes Standby

Prohibit to turn ON the compressor for 3 minutes after turning it off.
(Except when defrosting. (Only for Heat Pump Model).)

3.3.5 Compressor Protection Function

When turning the compressor from OFF to ON, the upper limit of frequency must be set as follows. (The function must not be used when defrosting (only for heat pump model).)

FCG 3	88
FCG 2	64
FCG 1	48
TCG 1	240
TCG 2	360
TCG 3	180

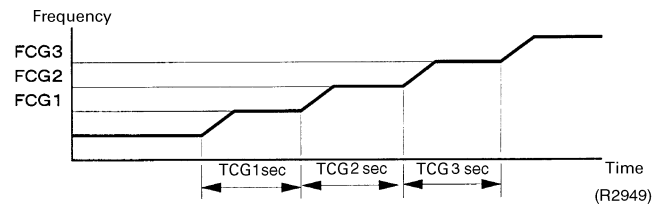

3.4 Discharge Pipe Control

Outline

The discharge pipe temperature is used as the compressor's internal temperature. If the discharge pipe temperature rises above a certain level, the operating frequency upper limit is set to keep this temperature from going up further.

Detail

Divide the Zone

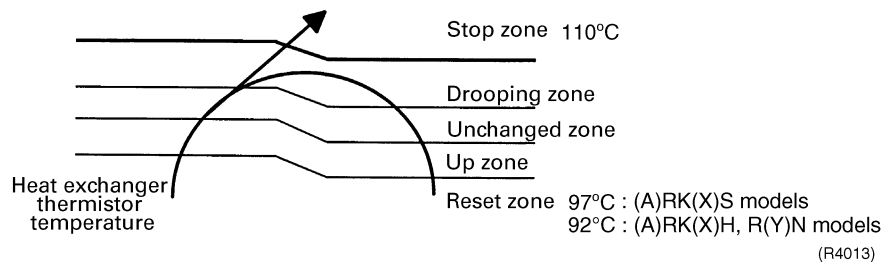

Management within the Zones

Zone	Control contents
Stop zone	When the temperature reaches the stop zone, stop the compressor and correct abnormality.
Drooping zone	Start the timer, and the frequency will be drooping.
Unchanged zone	Keep the upper limit of frequency.
Return / Reset zone	Cancel the upper limit of frequency.

3.5 Input Current Control

Outline

Detect an input current by the CT during the compressor is running, and set the frequency upper limit from such input current.

In case of heat pump model, this control is the upper limit control function of the frequency which takes priority of the lower limit of four way valve activating compensation.

Detail

The frequency control will be made within the following zones.

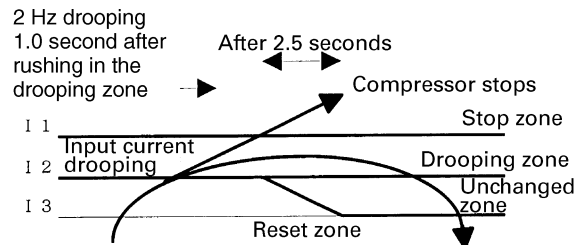

(R1378)

When a “stop current” continues for 2.5 seconds after rushing on the stop zone, the compressor operation stops.

If a “drooping current” is continues for 1.0 second after rushing on the drooping zone, the frequency will be 2 Hz drooping.

Repeating the above drooping continues until the current rushes on the drooping zone without change.

In the unchanged zone, the frequency limit will remain.

In the return / reset zone, the frequency limit will be cancelled.

Limitation of current drooping and stop value according to the outdoor air temperature

1. In case the operation mode is cooling
 - The current droops when outdoor air temperature becomes higher than a certain level (model by model).
2. In case the operation mode is heating (only for heat pump model)
 - The current droops when outdoor air temperature becomes higher than a certain level (model by model).

3.6 Freeze-up Protection Control

Outline

During cooling operation, the signals being sent from the indoor unit allow the operating frequency limitation and then prevent freezing of the indoor heat exchanger. (The signal from the indoor unit must be divided into the zones as the followings.

Detail

Conditions for Start Controlling

Judge the controlling start with the indoor heat exchanger temperature after 2 sec from operation start.

Control in Each Zone

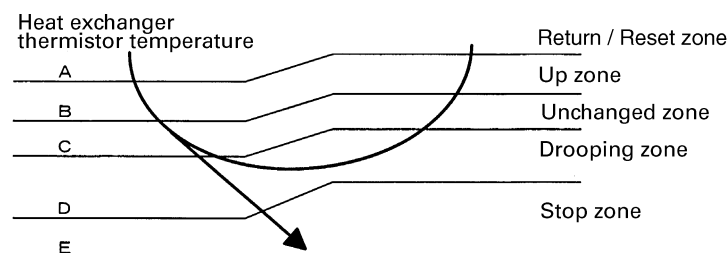

(R1379)

3.7 Heating Peak-cut Control

Outline **Heat Pump Only**
During heating operation, the signals being sent from the indoor unit allow the operating frequency limitation and prevent abnormal high pressure. (The signal from the indoor unit must be divided as follows.)

Detail **Conditions for Start Controlling**
Judge the controlling start with the indoor heat exchanger temperature after 2 sec. from operation start.

Control in Each Zone

The heat exchange intermediate temperature of indoor unit controls the following.

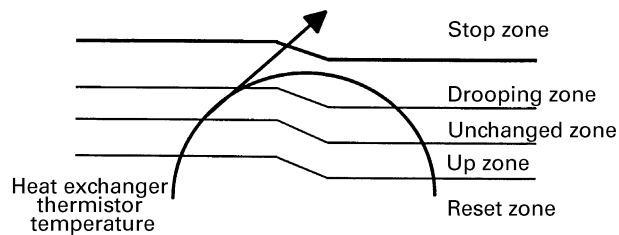

(R1380)

3.8 Fan Control

Outline Fan control is carried out according to the following priority.

1. Fan control when defrosting
2. Fan OFF delay when stopped
3. ON/OFF control when cooling operation
4. Tap control when drooping function is working
5. Fan control when forced operation
6. Fan control in low noise mode
7. Fan control during heating operation
8. Fan control in the quiet mode
9. Fan control in the powerful mode
10. Fan control for pressure difference upkeep

Detail **Fan OFF Control when Stopped**
 ■ Fan OFF delay for 60 seconds must be made when the compressor is stopped.

3.9 Liquid Compression Protection Function 2

Outline In order to obtain the dependability of the compressor, the compressor must be stopped according to the conditions of the temperature of the outdoor air and outdoor heat exchanger.

Detail ■ Operation stop depending on the outdoor air temperature
Compressor operation turns OFF under the conditions that the system is in cooling operation and outdoor air temperature is below -10°C (0°C for (A)RK(X)H, R(Y)N models).

3.10 Defrost Control

Outline

Heat Pump Only

Defrosting is carried out by the cooling cycle (reverse cycle). The defrosting time or outdoor heat exchanger temperature must be more than its fixed value when finishing.

Detail

Conditions for Starting Defrost

The starting conditions must be made with the outdoor air temperature and heat exchanger temperature. Under the conditions that the system is in heating operation, 6 minutes after the compressor is started and more than 44 minutes of accumulated time pass since the start of the operation or ending the defrosting.

Conditions for Canceling Defrost

The judgment must be made with heat exchanger temperature. (4°C~22°C)

(A)RK(X)S models

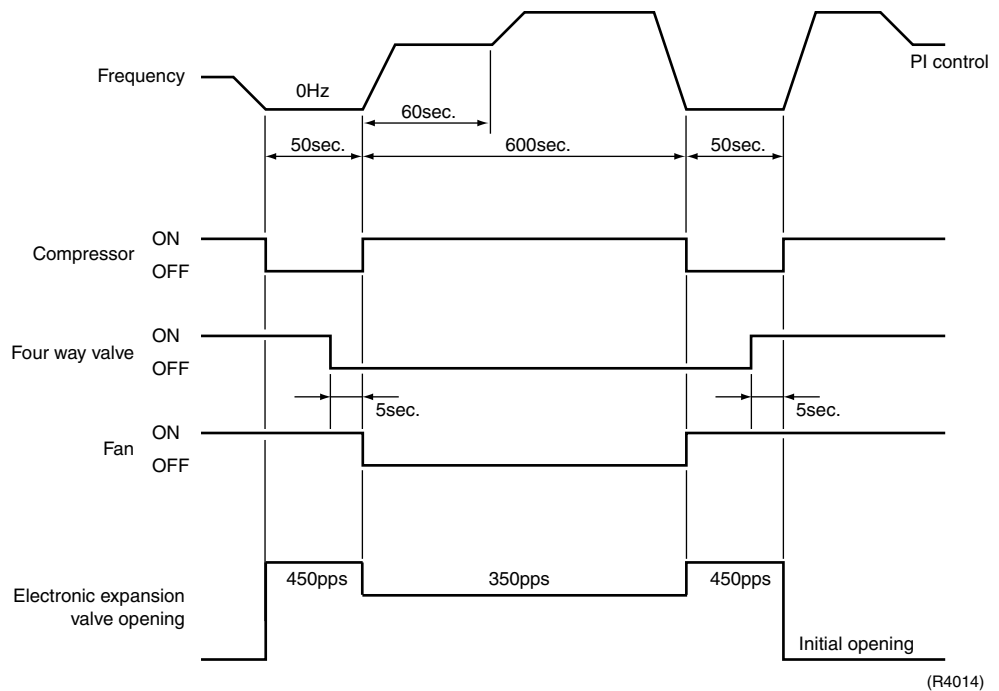

(A)RK(X)H, R(Y)N models

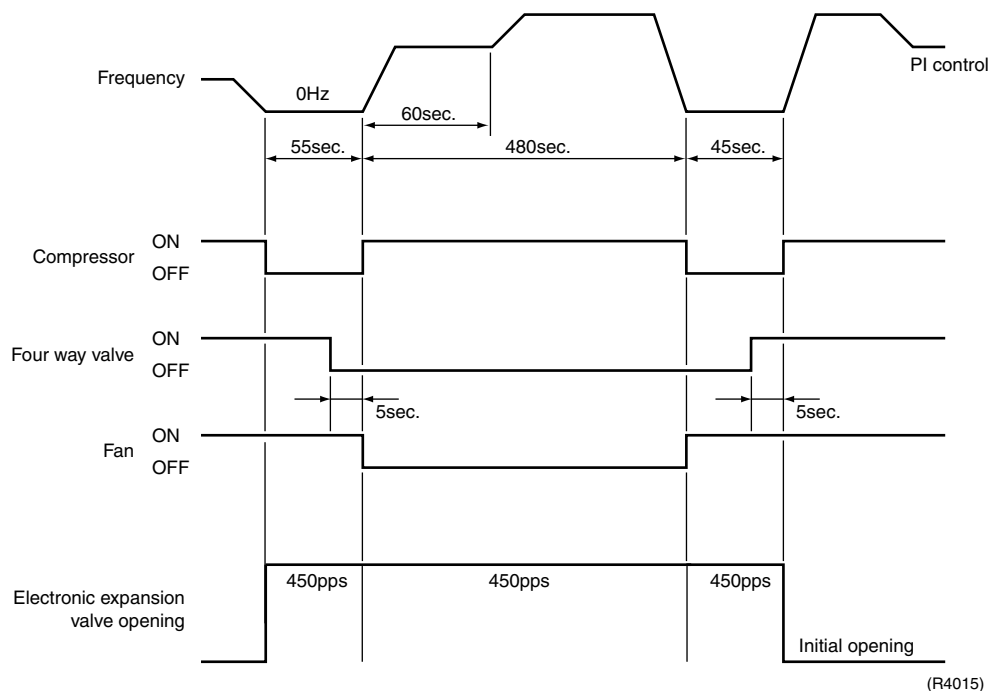

3.11 Electronic Expansion Valve Control

Outline

The following items are included in the electronic expansion valve control.

Electronic expansion valve is fully closed

1. Electronic expansion valve is fully closed when turning on the power.
2. Pressure equalizing control

Open Control

1. Electronic expansion valve control when starting operation
2. Control when frequency changed
3. Control for defrosting (only for heat pump model)
4. Control when a discharge pipe temperature is abnormally high
5. Control when the discharge pipe thermistor is disconnected

Feedback Control

1. Discharge pipe temperature control

Detail

The followings are the examples of control which function in each mode by the electronic expansion valve control.

Operation pattern		Control when frequency changed	Control for abnormally high discharge pipe temperature	
When power is turned ON	○ : function × : not function			
↓		Fully closed when power is turned ON	×	×
Cooling operation		Open control when starting	×	○
↓		(Control of target discharge pipe temperature)	○	○
Stop		Pressure equalizing control	×	×
Heating operation (only for heat pump model)		Open control when starting	×	○
↓		(Control of target discharge pipe temperature)	○	○
Stop		(Defrost control FD=1) (only for heat pump model)	×	×
↓		Pressure equalizing control	×	×
Heating operation (only for heat pump model)		Open control when starting	×	○
↓		Control of discharge pipe thermistor disconnection	↓	Continue
Stop		Pressure equalizing control	×	×

(R2833)

3.11.1 Fully Closing with Power ON

Initialize the electronic expansion valve when turning on the power, set the opening position and develop pressure equalizing.

3.11.2 Pressure Equalization Control

When the compressor is stopped, open and close the electronic expansion valve and develop pressure equalization.

3.11.3 Opening Limit

Outline

Limit a maximum and minimum opening of the electronic expansion valve.

Detail

- A maximum electronic expansion valve opening : 450 pulses
 - A minimum electronic expansion valve opening : 52 pulses
- The electronic expansion valve is fully closed in the room where cooling is stopped and is opened with fixed opening during defrosting.

3.11.4 Starting Operation Control

Control the electronic expansion valve opening when the system is starting, and prevent the system to be super heated or moistened.

3.11.5 High Temperature of the Discharge Pipe

When the compressor is operating, if the discharge pipe temperature exceeds a certain value, open the electronic expansion valve and remove the refrigerant to the low pressure side and lower discharge temperature.

3.11.6 Disconnection of the Discharge Pipe Thermistor

Outline

Detect a disconnected discharge pipe thermistor by comparing the discharge pipe temperature with the condensation temperature. If any is disconnected, open the electronic expansion valve according to the outdoor air temperature and the operating frequency and operate for a specified time, and then stop.

After 3 minutes of waiting, restart the unit and check if any is disconnected. If any is disconnected stop the system after operating for a specified time. If the disconnection is detected 4 times in succession, then the system will be down.

Detail

Detect Disconnection

If the timer for open control (cooling : 12min., heating : 15min.) becomes over, and the 9-minute timer for the compressor operation continuation is not counting time, the following adjustment must be made.

1. When the operation mode is cooling
 - When the discharge pipe temperature is lower than the outdoor heat exchanger temperature, the discharge pipe thermistor disconnection must be ascertained.
2. When the operation mode is heating (only for heat pump model)
 - When the discharge pipe temperature is lower than the max temperature of indoor unit heat exchanger, the discharge pipe thermistor disconnection must be ascertained.

Adjustment when the thermistor is disconnected

When compressor stop repeats specified time, the system should be down.

3.11.7 Control when frequency is changed

When the target discharge pipe temperature control is active, if the target frequency is changed for a specified value in a certain time period, cancel the target discharge pipe temperature control and change the target opening of the electronic expansion valve according to the shift.

3.11.8 Target Discharge Pipe Temperature Control

Obtain the target discharge pipe temperature from the indoor and outdoor heat exchanger temperature, and adjust the electronic expansion valve opening so that the actual discharge pipe temperature become close to that temperature. (Indirect SH control using the discharge pipe temperature)

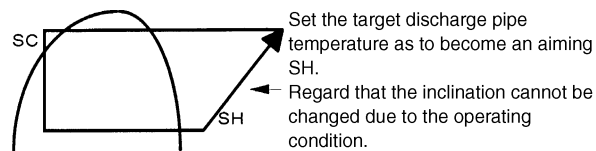

(R1389)

Determine a correction value of the electronic expansion valve compensation and drive it according to the deflection of the target discharge temperature and actual discharge temperature, and the discharge temperature variation by the 20 sec.

3.12 Malfunctions

3.12.1 Sensor Malfunction Detection

Sensor malfunction may occur in the thermistor.

Relating to Thermistor Malfunction

1. Outdoor heat exchanger thermistor
2. Discharge pipe thermistor
3. Fin thermistor
4. Outdoor air thermistor

3.12.2 Detection of Overload and Over Current

Outline

In order to protect the inverter, detect an excessive output current, and for protecting compressor, monitor the OL operation.

Detail

- If the OL (compressor head) temperature exceeds 120°C (depending on the model), the compressor gets interrupted.
- If the inverter current exceeds 22 A, the compressor gets interrupted too.

3.12.3 Insufficient Gas Control

Outline

There are three ways of control to detect insufficient gas.

I Detecting by power consumption

If the power consumption is below the specified value and the frequency is higher than the specified frequency, it is regarded as insufficient gas.

The power consumption is weak comparing with that in the normal operation when gas is insufficient, and gas insufficiency is detected by checking a power consumption.

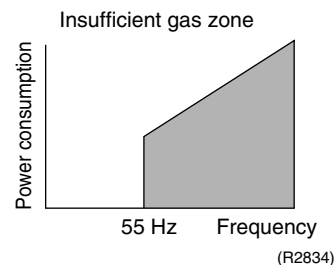

II Detecting by discharge pipe temperature

If the discharge temperature is higher than the target discharge pipe temperature, and the electronic expansion valve is fully open (450 pulses) more than the specified time, it is regarded as insufficient gas.

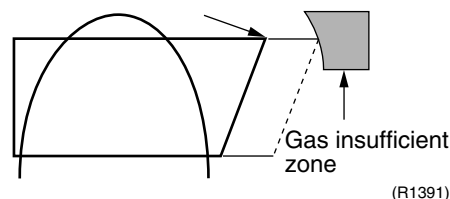

III Detecting by the difference of temperature

If the difference between inhale and exhale temperature is smaller than the specified value, it is regarded as insufficient gas.

Detail**I Judgment by power consumption**

When an output frequency is exceeds 55 Hz and the input current is less than specified value, the adjustment is made for insufficient gas.

II Judgment by discharge pipe temperature

When discharge pipe temperature is 20°C higher than target value and the electronic expansion valve opening is 450 pulses (max.), the adjustment is made for insufficient gas.

III Judgment by the difference of temperature

When the difference of the temperature is smaller than Δ , it is regarded as insufficient gas.

		Δ
Cooling	room temperature – indoor heat exchanger temperature	4.0°C
	outdoor heat exchanger temperature – outdoor temperature	4.0°C
Heating	indoor heat exchanger temperature – room temperature	4.0°C
	outdoor temperature – outdoor heat exchanger temperature	3.0°C

3.13 Forced Operation Mode

Outline

Forced operating mode includes only forced cooling.

Detail**Forced Cooling**

Item	Forced Cooling
Forced operation allowing conditions	1) The outdoor unit is not abnormal and not in the 3-minute stand-by mode. 2) The operating mode of the outdoor unit is the stop mode. 3) The forced operation is ON. The forced operation is allowed when the above “and” conditions are met.
Starting/adjustment	If the forced operation switch is pressed as the above conditions are met.
1) Command frequency	■ 68 Hz
2) Electronic expansion valve opening	■ Depending on the capacity of the indoor unit.
3) Outdoor unit adjustment	■ Compressor is in operation
4) Indoor unit adjustment	■ Transmit the command of forced draft to the indoor unit.
End	1) When the forced operation switch is pressed again. 2) The operation is to end automatically after 15 min.
Others	The protect functions are prior to all others in the forced operation.

3.14 Additional Function

3.14.1 Powerful Operation Mode

Compressor operating frequency is increased to P1 Max. (Max. Hz of operating room) and outdoor unit airflow rate is increased.

3.14.2 Voltage Detection Function

Power supply voltage is detected each time equipment operation starts.

3.15 Facility Setting Jumper (cooling at low outdoor temperature)

Outline

This function is limited only for facilities (the target of air conditioning is equipment (such as computer)). Never use it in a residence or office (the space where there is a human).

Detail

You can expand the operation range to -15°C by cutting jumper 8 (J8) on the PCB. If the outdoor temperature falls to -20°C or lower, the operation will stop. If the outdoor temperature rises, the operation will start again.

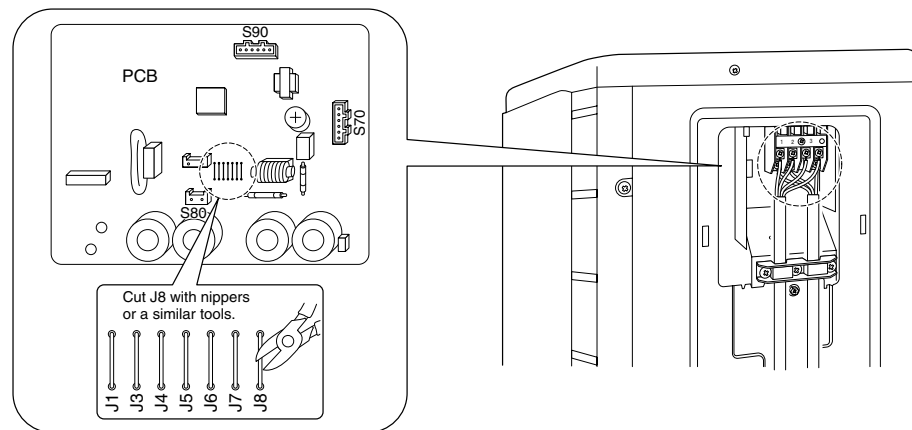

Caution

1. If the outdoor unit is installed where the heat exchanger of the unit is exposed to direct wind, provide a windbreak wall.
2. Intermittent noises may be produced by the indoor unit due to the outdoor fan turning on and off when using facility settings.
3. Do not place humidifiers or other items which might raise the humidity in rooms where facility settings are being used.
A humidifier might cause dew jumping from the indoor unit outlet vent.
4. Cutting jumper 8 (J8) sets the indoor fan tap to the highest position. Notify the user about this.

Part 5

System Configuration

1. System Configuration.....	60
2. Instruction.....	61
2.1 Safety precautions.....	61
2.2 Names of parts.....	63
2.3 Preparation before Operation.....	66
2.4 AUTO · DRY · COOL · HEAT · FAN Operation.....	69
2.5 Adjusting the Air Flow Direction.....	71
2.6 POWERFUL Operation.....	73
2.7 OUTDOOR UNIT SILENT Operation.....	74
2.8 HOME LEAVE Operation.....	75
2.9 INTELLIGENT EYE Operation.....	77
2.10 TIMER Operation.....	79
2.11 Care and Cleaning.....	81
2.12 Troubleshooting.....	84

1. System Configuration

After the installation and test operation of the room air conditioner have been completed, it should be operated and handled as described below. Every user would like to know the correct method of operation of the room air conditioner, to check if it is capable of cooling (or heating) well, and to know a clever method of using it.



In order to meet this expectation of the users, giving sufficient explanations taking enough time can be said to reduce about 80% of the requests for servicing. However good the installation work is and however good the functions are, the customer may blame either the room air conditioner or its installation work because of improper handling. The installation work and handing over of the unit can only be considered to have been completed when its handling has been explained to the user without using technical terms but giving full knowledge of the equipment.

2. Instruction

i Note: This instruction is appropriate for FTK(X)S-C models.

2.1 Safety precautions

- Keep this manual where the operator can easily find them.
- Read this manual attentively before starting up the unit.
- For safety reason the operator must read the following cautions carefully.
- This manual classifies precautions into WARNINGS and CAUTIONS. Be sure to follow all precautions below: they are all important for ensuring safety.

 WARNING If you do not follow these instructions exactly, the unit may cause property damage, personal injury or loss of life.	 CAUTION If you do not follow these instructions exactly, the unit may cause minor or moderate property damage or personal injury.
---------------------------------------------------------------------------------------------------------------------------------------------------------------------------------------------------------------------------	--------------------------------------------------------------------------------------------------------------------------------------------------------------------------------------------------------------------------------

 Never do.

 Be sure to earth the air conditioner.

 Never touch the air conditioner (including the remote controller) with a wet hand.

 Be sure to follow the instructions.



 Never cause the air conditioner (including the remote controller) to get wet.

WARNING

- In order to avoid fire, explosion or injury, do not operate the unit when harmful, among which flammable or corrosive gases, are detected near the unit. 
- It is not good for health to expose your body to the air flow for a long time.
- Do not put a finger, a rod or other objects into the air outlet or inlet. As the fan is rotating at a high speed, it will cause injury.
- Do not attempt to repair, relocate, modify or reinstall the air conditioner by yourself. Incorrect work will cause electric shocks, fire etc.
For repairs and reinstallation, consult your Daikin dealer for advice and information.

- The refrigerant used in the air conditioner is safe. Although leaks should not occur, if for some reason any refrigerant happens to leak into the room, make sure it does not come in contact with any flame as of gas heaters, kerosene heaters or gas range. 
- If the air conditioner is not cooling (heating) properly, the refrigerant may be leaking, so call your dealer. When carrying out repairs accompanying adding refrigerant, check the content of the repairs with our service staff.
- Do not attempt to install the air conditioner by your self. Incorrect work will result in water leakage, electric shocks or fire. For installation, consult the dealer or a qualified technician.
- In order to avoid electric shock, fire or injury, if you detect any abnormally such as smell of fire, stop the operation and turn off the breaker. And call your dealer for instructions.

CAUTION

- The air conditioner must be earthed. Incomplete earthing may result in electric shocks. Do not connect the earth line to a gas pipe, water pipe, lightning rod, or a telephone earth line. 
- In order to avoid any quality deterioration, do not use the unit for cooling precision instruments, food, plants, animals or works of art. 
- Never expose little children, plants or animals directly to the air flow.
- Do not place appliances which produce open fire in places exposed to the air flow from the unit or under the indoor unit. It may cause incomplete combustion or deformation of the unit due to the heat.
- Do not block air inlets nor outlets. Impaired air flow may result in insufficient performance or trouble.

- Do not stand or sit on the outdoor unit. Do not place any object on the unit to avoid injury, do not remove the fan guard.
- Do not place anything under the indoor or outdoor unit that must be kept away from moisture. In certain conditions, moisture in the air may condense and drip.
- After a long use, check the unit stand and fittings for damage.
- Do not touch the air inlet and aluminum fins of outdoor unit. It may cause injury.
- The appliance is not intended for use by young children or infirm persons without supervision.
- Young children should be supervised to ensure that they do not play with the appliance.

- To avoid oxygen deficiency, ventilate the room sufficiently if equipment with burner is used together with the air conditioner.
- Before cleaning, be sure to stop the operation, turn the breaker off or pull out the supply cord.
- Do not connect the air conditioner to a power supply different from the one as specified. It may cause trouble or fire.
- Depending on the environment, an earth leakage breaker must be installed. Lack of an earth leakage breaker may result in electric shocks.
- Arrange the drain hose to ensure smooth drainage. Incomplete draining may cause wetting of the building, furniture etc.



- Do not operate the air conditioner with wet hands.



- Do not wash the indoor unit with excessive water, only use a slightly wet cloth.
- Do not place things such as vessels containing water or anything else on top of the unit. Water may penetrate into the unit and degrade electrical insulations, resulting in an electric shock.



Installation site

- To install the air conditioner in the following types of environments, consult the dealer.
 - Places with an oily ambient or where steam or soot occurs.
 - Salty environment such as coastal areas.
 - Places where sulfide gas occurs such as hot springs.
 - Places where snow may block the outdoor unit.

The drain from the outdoor unit must be discharged to a place of good drainage.

Consider nuisance to your neighbours from noises

- For installation, choose a place as described below.
 - A place solid enough to bear the weight of the unit which does not amplify the operation noise or vibration.
 - A place from where the air discharged from the outdoor unit or the operation noise will not annoy your neighbours.

Electrical work

- For power supply, be sure to use a separate power circuit dedicated to the air conditioner.

System relocation

- Relocating the air conditioner requires specialized knowledge and skills. Please consult the dealer if relocation is necessary for moving or remodeling

2.2 Names of parts

■ Indoor Unit

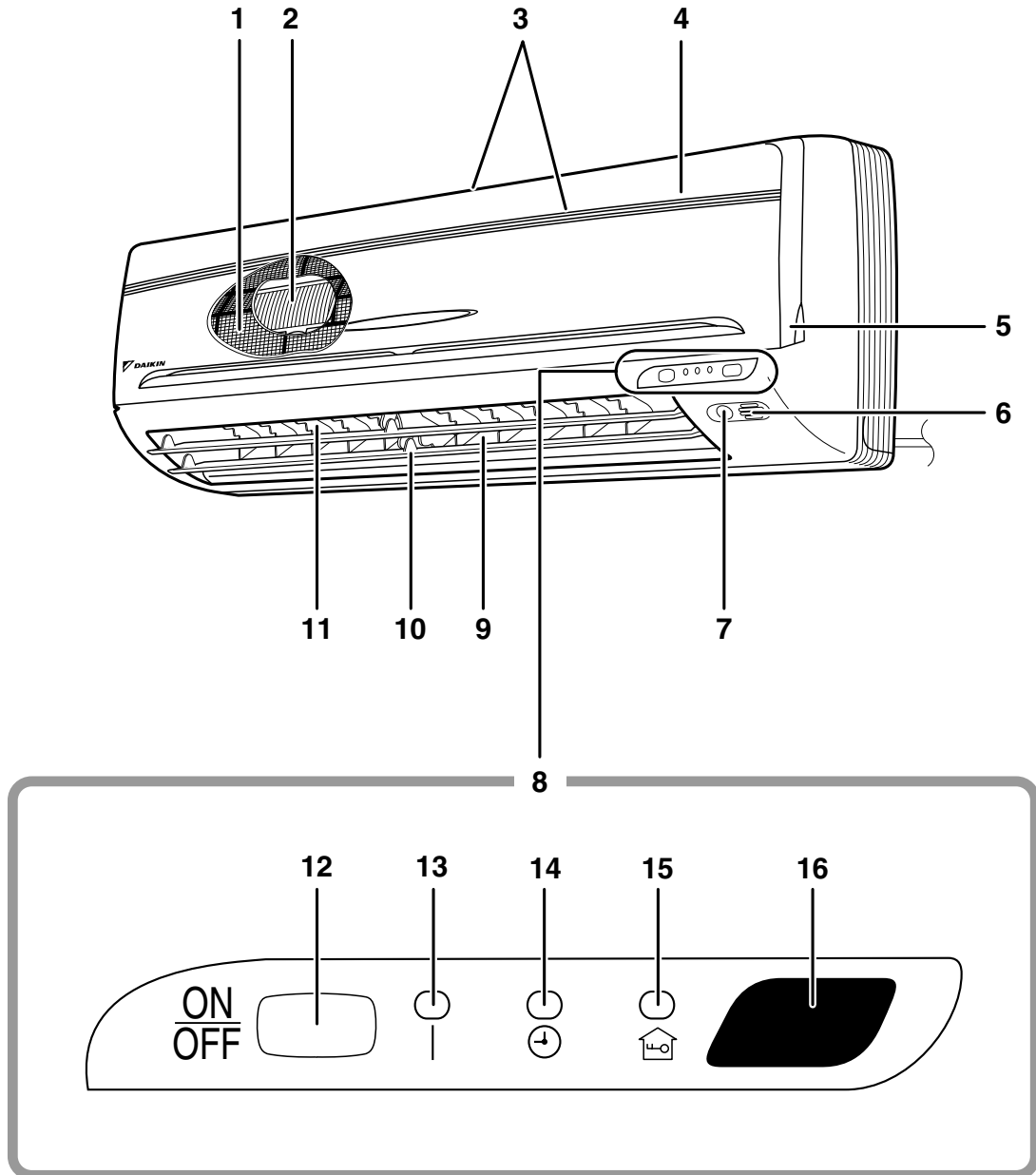

■ Outdoor Unit

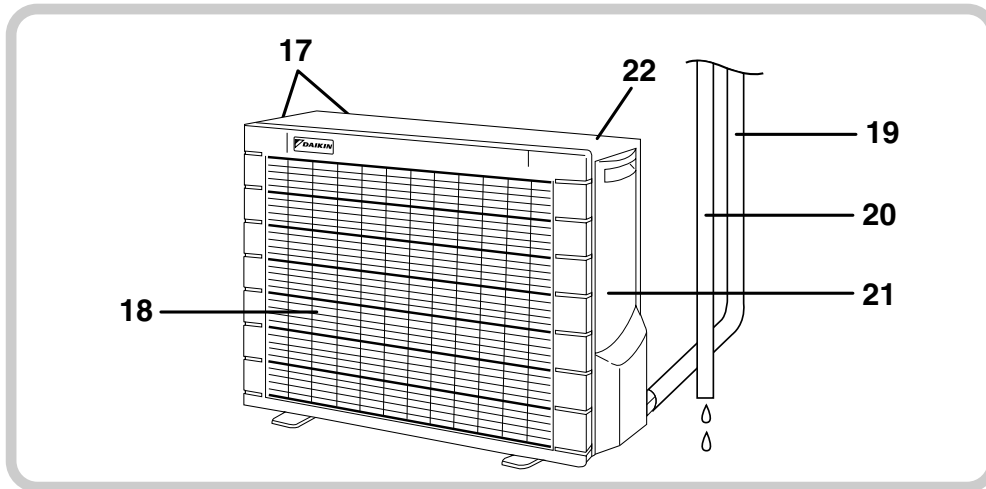

■ Indoor Unit

1. Air filter
2. Air purifying filter with photocatalytic deodorizing function:
 - These filters are attached to the inside of the air filters.
3. Air inlet
4. Front grille
5. Grille tab
6. Room temperature sensor:
 - It senses the air temperature around the unit.
7. INTELLIGENT EYE sensor:
 - It detects the movements of people and automatically switches between normal operation and energy saving operation. (page 18.)
8. Display
9. Air outlet
10. Flaps (horizontal blades): (page 12.)
11. louvers (vertical blades):
 - The louvers are inside of the air outlet. (page 13.)

12. Indoor Unit ON/OFF switch: (page 10.)

- Push this switch once to start operation. Push once again to stop it.
- The operation mode refers to the following table.

	Mode	Temperature setting	Air flow rate
FTKS	COOL	22°C	AUTO
FTXS	AUTO	25°C	AUTO

- This switch is useful when the remote controller is missing.

13. Operation lamp (green)

14. TIMER lamp (yellow): (page 20.)

15. HOME LEAVE lamp (red): (page 16.)

16. Signal receiver:

- It receives signals from the remote controller.
- When the unit receives a signal, you will hear a short beep.
 - Operation startbeep-beep
 - Settings changedbeep
 - Operation stopbeeeeeeep

■ Outdoor Unit

17. Air inlet: (Back and side)
18. Air outlet
19. Refrigerant piping and inter-unit cable
20. Drain hose

21. Earth terminal:

- It is inside of this cover.

22. Outside air temperature sensor:

- It senses the ambient temperature around the unit.

Appearance of the outdoor unit may differ from some models.

■ Remote Controller

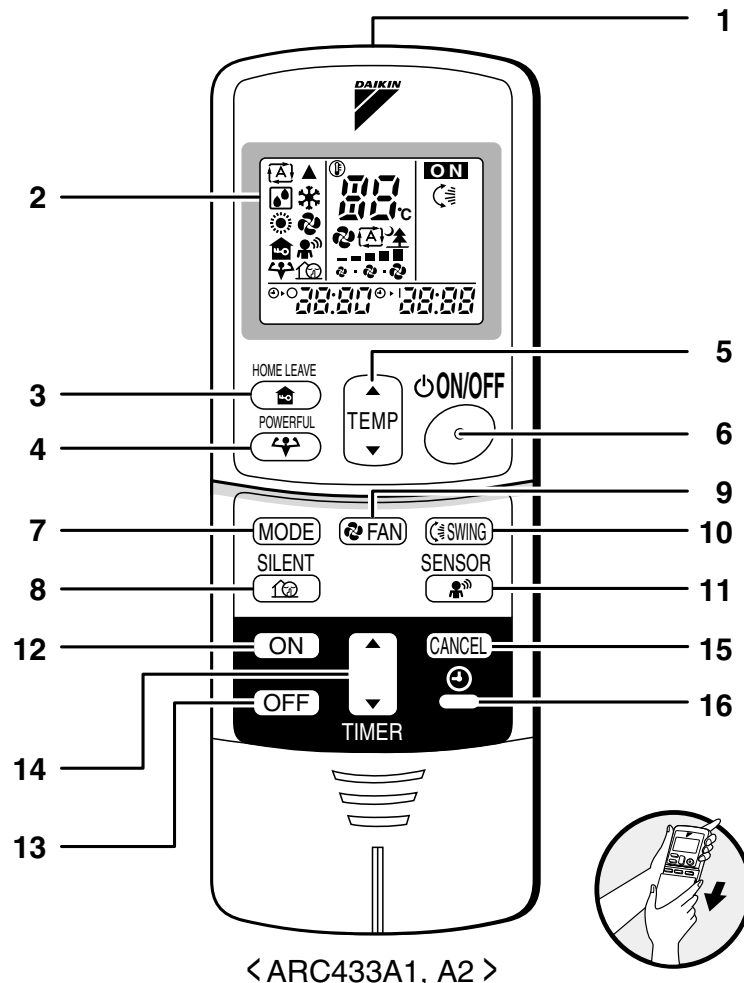

1. Signal transmitter:

- It sends signals to the indoor unit.

2. Display:

- It displays the current settings.
(In this illustration, each section is shown with all its displays ON for the purpose of explanation.)

3. HOME LEAVE button:

- for HOME LEAVE operation (page 16.)

4. POWERFUL button:

- for POWERFUL operation (page 14.)

5. TEMPERATURE adjustment buttons:

- It changes the temperature setting.

6. ON/OFF button:

- Press this button once to start operation.
Press once again to stop it.

7. MODE selector button:

- It selects the operation mode.

(AUTO/DRY/COOL/HEAT/FAN) (page 10.)

8. SILENT button: for OUTDOOR UNIT SILENT operation (page 15.)

9. FAN setting button:

- It selects the air flow rate setting.

10. SWING button: (page 12.)

11. SENSOR button: for INTELLIGENT EYE operation (page 18.)

12. ON TIMER button: (page 21.)

13. OFF TIMER button: (page 20.)

14. TIMER Setting button:

- It changes the time setting.

15. TIMER CANCEL button:

- It cancels the timer setting.

16. CLOCK button: (page 9.)

2.3 Preparation before Operation

■ To set the batteries

1. Press  with a finger and slide the front cover to take it off.
2. Set two dry batteries (AAA).
3. Set the front cover as before.

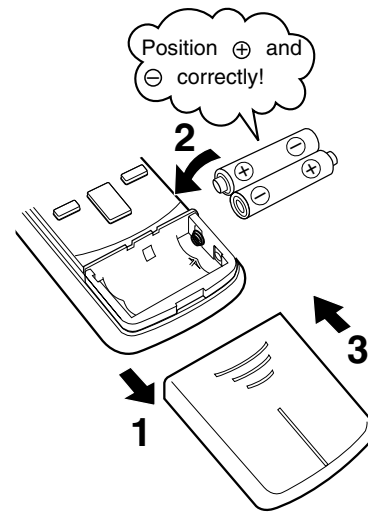

ATTENTION

■ About batteries

- When replacing the batteries, use batteries of the same type, and replace the two old batteries together.
- When the system is not used for a long time, take the batteries out.
- We recommend replacing once a year, although if the remote controller display begins to fade or if reception deteriorates, please replace with new alkali batteries. Using manganese batteries reduces the lifespan.
- The attached batteries are provided for the initial use of the system.
The usable period of the batteries may be short depending on the manufactured date of the air conditioner.

■ To operate the remote controller

- To use the remote controller, aim the transmitter at the indoor unit. If there is anything to block signals between the unit and the remote controller, such as a curtain, the unit will not operate.
- Do not drop the remote controller. Do not get it wet.
- The maximum distance for communication is about 7 m.

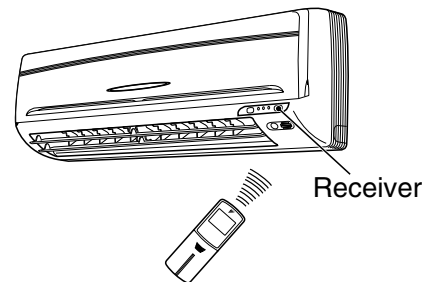

■ To fix the remote controller holder on the wall

1. Choose a place from where the signals reach the unit.
2. Fix the holder to a wall, a pillar, etc. with the screws supplied with the holder.
3. Place the remote controller in the remote controller holder.

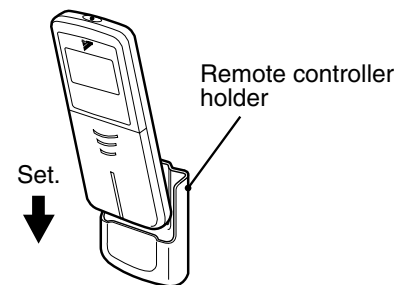

- To remove, pull it upwards.

ATTENTION

■ About remote controller

- Never expose the remote controller to direct sunlight.
- Dust on the signal transmitter or receiver will reduce the sensitivity. Wipe off dust with soft cloth.
- Signal communication may be disabled if an electronic-starter-type fluorescent lamp (such as inverter-type lamps) is in the room. Consult the shop if that is the case.
- If the remote controller signals happen to operate another appliance, move that appliance to somewhere else, or consult the shop.

■ To set the clock

1. Press “CLOCK button”.

0:00 is displayed.

🕒 blinks.

2. Press “TIMER setting button” to set the clock to the present time.

Holding down “▲” or “▼” button rapidly increases or decreases the time display.

3. Press “CLOCK button”.

🕒 blinks.

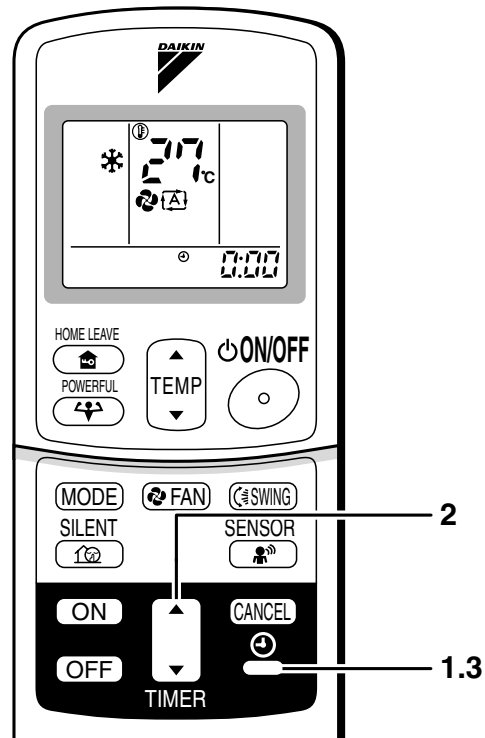

■ Turn the breaker ON

- Turning ON the breaker opens the flap, then closes it again. (This is a normal procedure.)

NOTE

■ Tips for saving energy

- Be careful not to cool (heat) the room too much. Keeping the temperature setting at a moderate level helps save energy.
- Cover windows with a blind or a curtain. Blocking sunlight and air from outdoors increases the cooling (heating) effect.
- Clogged air filters cause inefficient operation and waste energy. Clean them once in about every two weeks.

Recommended temperature setting

For cooling: 26°C – 28°C
For heating: 20°C – 24°C

■ Please note

- The air conditioner always consumes 15-35 watts of electricity even while it is not operating.
- If you are not going to use the air conditioner for a long period, for example in spring or autumn, turn the breaker OFF.
- Use the air conditioner in the following conditions.

Mode	Operating conditions	If operation is continued out of this range
COOL	Outdoor temperature: (2MK(X)S) 10 to 46 °C (3/4MK(X)S) -10 to 46 °C (RK(X)S) -10 to 46 °C (RK(X)H) 10 to 46 °C Indoor temperature: 18 to 32 °C Indoor humidity: 80% max.	<ul style="list-style-type: none"> • A safety device may work to stop the operation. (In multi system, it may work to stop the operation of the outdoor unit only.) • Condensation may occur on the indoor unit and drip.
HEAT	Outdoor temperature: (2MXS) -10 to 21 °C (3/4MXS) -15 to 21 °C (RXS) -15 to 21 °C (RXH) -10 to 21 °C Indoor temperature: 10 to 30 °C	<ul style="list-style-type: none"> • A safety device may work to stop the operation.
DRY	Outdoor temperature: (2MK(X)S) 10 to 46 °C (3/4MK(X)S) -10 to 46 °C (RK(X)S) -10 to 46 °C (RK(X)H) 10 to 46 °C Indoor temperature: 18 to 32 °C Indoor humidity: 80% max.	<ul style="list-style-type: none"> • A safety device may work to stop the operation. • Condensation may occur on the indoor unit and drip.

- Operation outside this humidity or temperature range may cause a safety device to disable the system.

2.4 AUTO · DRY · COOL · HEAT · FAN Operation

The air conditioner operates with the operation mode of your choice.
 From the next time on, the air conditioner will operate with the same operation mode.

■ To start operation

1. Press “MODE selector button” and select a operation mode.

- Each pressing of the button advances the mode setting in sequence.

- Ⓐ: AUTO
- ☐: DRY
- ❄: COOL
- ☀: HEAT
- 🌀: FAN

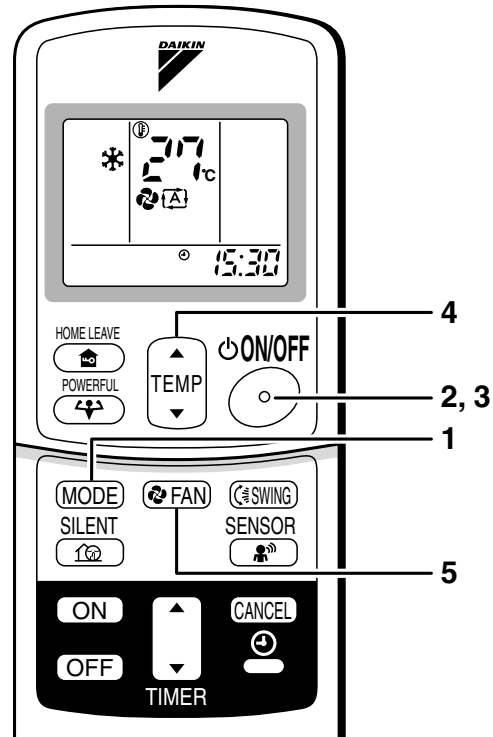
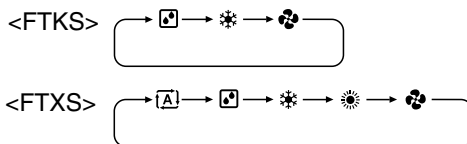

2. Press “ON/OFF button” .

- The OPERATION lamp lights up.

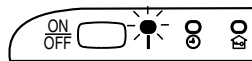

■ To stop operation

3. Press “ON/OFF button” again.

- Then OPERATION lamp goes off.





■ To change the temperature setting

4. Press “TEMPERATURE adjustment button”

DRY or FAN mode	AUTO or COOL or HEAT mode
The temperature setting is not variable.	Press “▲” to raise the temperature and press “▼” to lower the temperature.
	Set to the temperature you like.

■ To change the air flow rate setting

5. Press “FAN setting button”.

DRY mode	AUTO or COOL or HEAT or FAN mode
The air flow rate setting is not variable.	Five levels of air flow rate setting from “  ” to “  ” plus “  ” “  ” are available. 

- Indoor unit quiet operation

When the air flow is set to “”, the noise from the indoor unit will become quieter.

Use this when making the noise quieter.

The unit might lose power when the fan strength is set to a weak level.

NOTE

■ Note on HEAT operation

- Since this air conditioner heats the room by taking heat from outdoor air to indoors, the heating capacity becomes smaller in lower outdoor temperatures. If the heating effect is insufficient, it is recommended to use another heating appliance in combination with the air conditioner.
- The heat pump system heats the room by circulating hot air around all parts of the room. After the start of heating operation, it takes some time before the room gets warmer.
- In heating operation, frost may occur on the outdoor unit and lower the heating capacity. In that case, the system switches into defrosting operation to take away the frost.
- During defrosting operation, hot air does not flow out of indoor unit.

■ Note on DRY operation

- The computer chip works to rid the room of humidity while maintaining the temperature as much as possible. It automatically controls temperature and fan strength, so manual adjustment of these functions is unavailable.

■ Note on AUTO operation

- In AUTO operation, the system selects an appropriate operation mode (COOL or HEAT) based on the room temperature at the start of the operation.
- The system automatically reselects setting at a regular interval to bring the room temperature to user-setting level.
- If you do not like AUTO operation, you can manually select the operation mode and setting you like.

■ Note on air flow rate setting

- At smaller air flow rates, the cooling (heating) effect is also smaller.

2.5 Adjusting the Air Flow Direction

You can adjust the air flow direction to increase your comfort.

■ To adjust the horizontal blades (flaps)

1. Press “SWING button”.

 The display will light up and the flaps will begin to swing.

2. When the flaps have reached the desired position, press “SWING button” once more.

The display will go blank.
The flaps will stop moving.

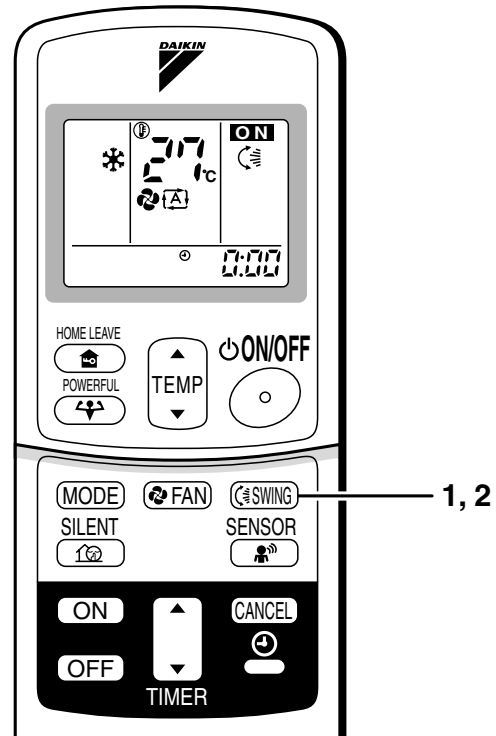

■ To adjust the vertical blades (louvers)

Hold the knob and move the louvers.

(You will find a knob on the left-side and the right-side blades.)

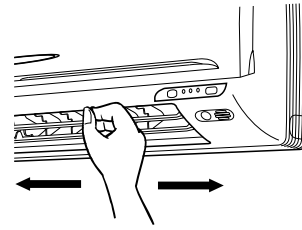

Notes on flaps and louvers angles

- When “**SWING button**” is selected, the flaps swinging range depends on the operation mode. (See the figure.)

■ ATTENTION

- Always use a remote controller to adjust the flaps angle. If you attempt to move it forcibly with hand when it is swinging, the mechanism may be broken.
- Be careful when adjusting the louvers. Inside the air outlet, a fan is rotating at a high speed.

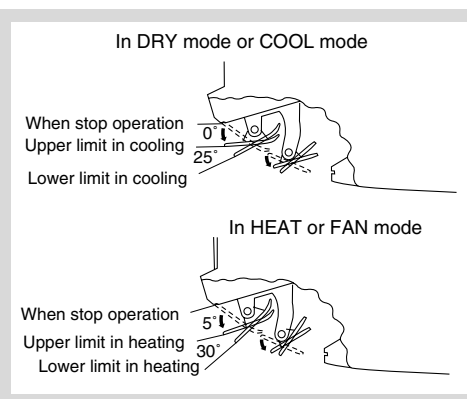

2.6 POWERFUL Operation

POWERFUL operation quickly maximizes the cooling (heating) effect in any operation mode. You can get the maximum capacity .

■ To start POWERFUL operation

1. Press “POWERFUL button”.
 - POWERFUL operation ends in 20 minutes. Then the system automatically operates again with the settings which were used before POWERFUL operation.
 - When using POWERFUL operation, there are some functions which are not available.

■ To cancel POWERFUL operation

2. Press “POWERFUL button” again.

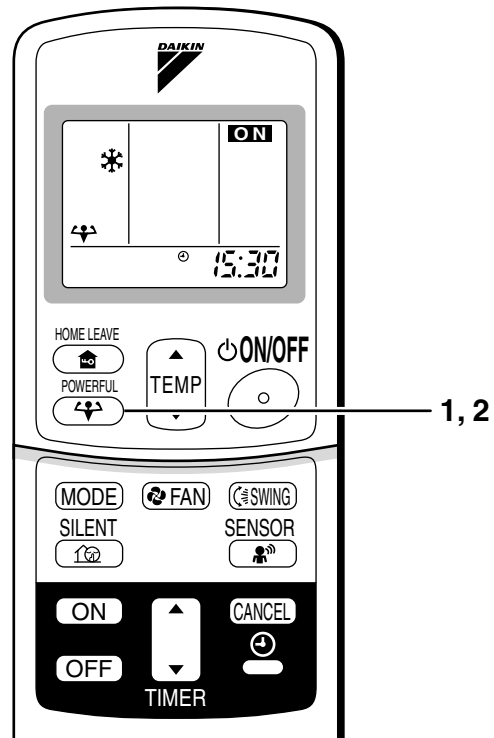

NOTE

■ Notes on POWERFUL operation

• In COOL and HEAT mode

To maximize the cooling (heating) effect, the capacity of outdoor unit must be increased and the air flow rate be fixed to the maximum setting. The temperature and air flow settings are not variable.

• In DRY mode

The temperature setting is lowered by 2.5°C and the air flow rate is slightly increased.

• In FAN mode

The air flow rate is fixed to the maximum setting.

2.7 OUTDOOR UNIT SILENT Operation

OUTDOOR UNIT SILENT operation lowers the noise level of the outdoor unit by changing the frequency and fan speed on the outdoor unit. This function is convenient during night.

■ To start OUTDOOR UNIT SILENT operation

1. Press "SILENT button".

■ To cancel OUTDOOR UNIT SILENT operation

2. Press "SILENT button" again.

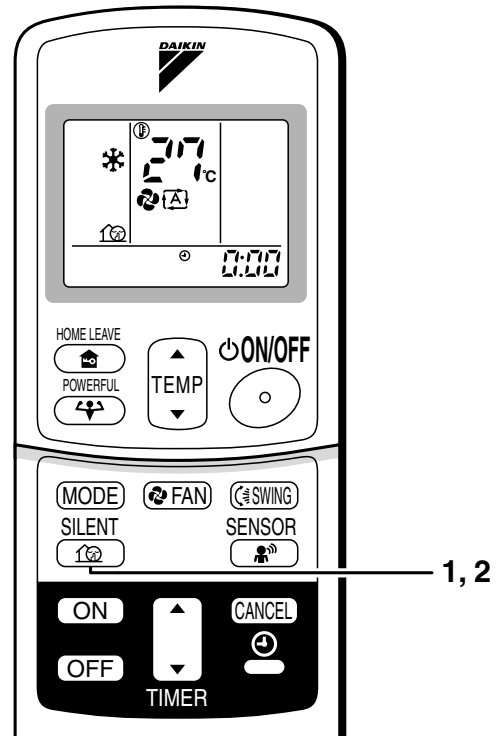

NOTE

■ Note on OUTDOOR UNIT SILENT operation

- This function is available in COOL, HEAT, and AUTO modes. (This is not available in FAN and DRY mode.)
- POWERFUL operation and OUTDOOR UNIT SILENT operation cannot be used at the same time. Priority is given to POWERFUL operation.
- If operation is stopped using the remote controller or the main unit ON/OFF switch when using OUTDOOR UNIT SILENT operation, "🏠" will remain on the remote controller display.
- This function does not work when connected to the RX(K)H20, 25, or 35CVMB.

2.8 HOME LEAVE Operation

HOME LEAVE operation is a function which allows you to record your preferred temperature and air flow rate settings.

■ To start HOME LEAVE operation

1. Press “HOME LEAVE button” .

- The HOME LEAVE lamp lights up.



■ To cancel HOME LEAVE operation

2. Press “HOME LEAVE button” again.

- The HOME LEAVE lamp goes off.

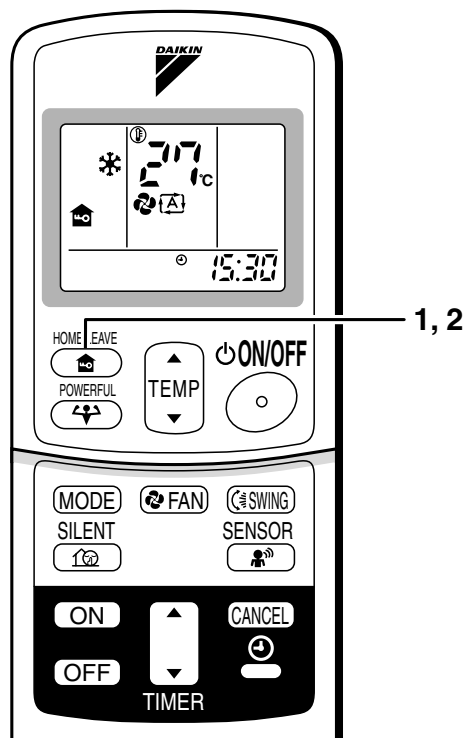

Before using HOME LEAVE operation.

■ To set the temperature and air flow rate for HOME LEAVE operation

When using HOME LEAVE operation for the first time, please set the temperature and air flow rate for HOME LEAVE operation. Record your preferred temperature and air flow rate.

	Initial setting		Selectable range	
	temperature	Air flow rate	temperature	Air flow rate
Cooling	25°C	AUTO	18-32°C	5 step, AUTO and SILENT
Heating	25°C	AUTO	10-30°C	5 step, AUTO and SILENT

1. Press “HOME LEAVE button”. Make sure “” is displayed in the remote controller display.
2. Adjust the set temperature with “▲” or “▼” as you like.
3. Adjust the air flow rate with “FAN” setting button as you like.

Home leave operation will run with these settings the next time you use the unit. To change the recorded information, repeat steps 1 – 3.

■ What's the HOME LEAVE operation

Is there a set temperature and air flow rate which is most comfortable, a set temperature and air flow rate which you use the most? HOME LEAVE operation is a function that allows you to record your favorite set temperature and air flow rate. You can start your favorite operation mode simply by pressing the HOME LEAVE button on the remote controller. This function is convenient in the following situations.

■ Useful in these cases.

1. Use as an energy-saving mode

Set the temperature 2-3° higher (cooling) or lower (heating) than normal. Setting the fan strength to the lowest setting allows the unit to be used in energy-saving mode. Also convenient for use while you are out or sleeping.

• Every day before you leave the house...

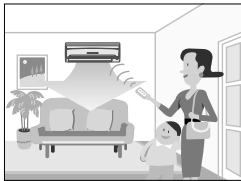

When you go out, push the "HOME LEAVE Operation" button, and the air conditioner will adjust capacity to reach the preset temperature for HOME LEAVE Operation.



When you return, you will be welcomed by a comfortably air conditioned room.

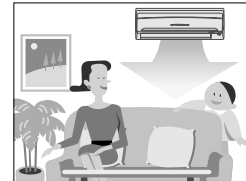

Push the "HOME LEAVE Operation" button again, and the air conditioner will adjust capacity to the set temperature for normal operation.

• Before bed...

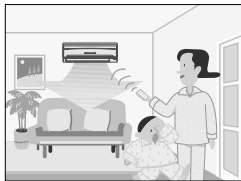

Set the unit to HOME LEAVE Operation before leaving the living room when going to bed.



The unit will maintain the temperature in the room at a comfortable level while you sleep.



When you enter the living room in the morning, the temperature will be just right. Disengaging HOME LEAVE Operation will return the temperature to that set for normal operation. Even the coldest winters will pose no problem!

2. Use as a favorite mode

Once you record the temperature and air flow rate settings you most often use, you can retrieve them by pressing HOME LEAVE button. You do not have to go through troublesome remote control operations.

NOTE

- Once the temperature and air flow rate for HOME LEAVE operation are set, those settings will be used whenever HOME LEAVE operation is used in the future. To change these settings, please refer to the "Before using HOME LEAVE operation" section above.
- HOME LEAVE operation is only available in COOL and HEAT mode. Cannot be used in AUTO, DRY, and FAN mode.
- HOME LEAVE operation runs in accordance with the previous operation mode (COOL or HEAT) before using HOME LEAVE operation.
- HOME LEAVE operation and POWERFUL operation cannot be used at the same time. Last button that was pressed has priority.
- The operation mode cannot be changed while HOME LEAVE operation is being used.
- When operation is shut off during HOME LEAVE operation, using the remote controller or the indoor unit ON/OFF switch, "🏠" will remain on the remote controller display.

2.9 INTELLIGENT EYE Operation

“INTELLIGENT EYE” is the infrared sensor which detects the human movement.

■ To start INTELLIGENT EYE operation

1. Press “SENSOR button”.

■ To cancel the INTELLIGENT EYE operation

2. Press “SENSOR button” again.

[EX.]

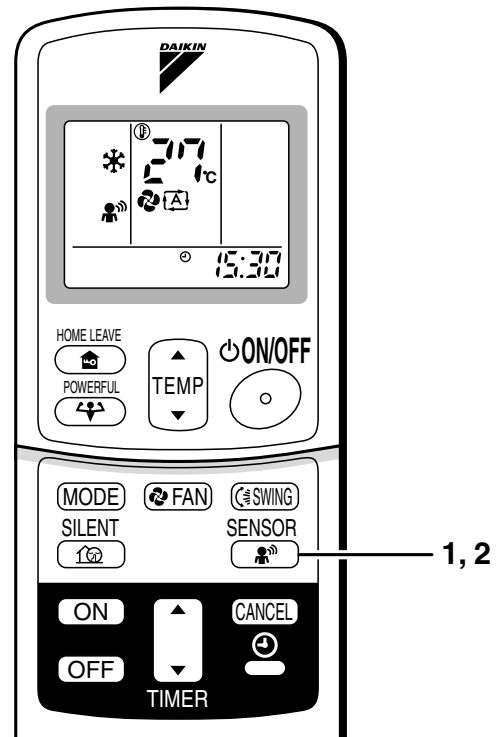
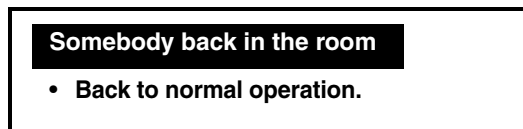
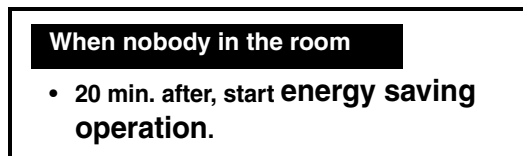
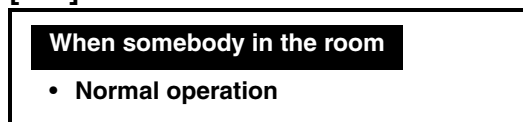

■ To adjust the angle of the INTELLIGENT EYE sensor

- You can adjust the angle of the INTELLIGENT EYE sensor to increase the detection area. (Adjustable angle: 15° to right and left of centre)

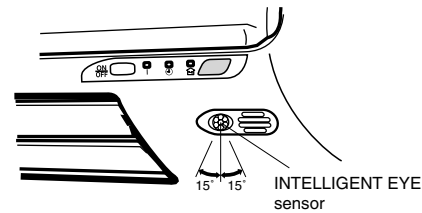

- Gently push and slide the sensor to adjust the angle.
- After adjusting the angle, wipe the sensor gently with a clean cloth, being careful not to scratch the sensor.

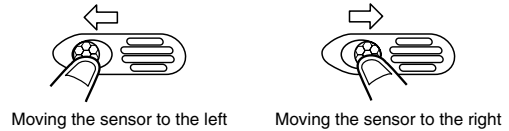

“INTELLIGENT EYE” is useful for Energy Saving

■ Energy saving operation

- Change the temperature -2°C in heating / $+2^{\circ}\text{C}$ in cooling / $+1^{\circ}\text{C}$ in dry mode from set temperature.
- Decrease the air flow rate slightly in fan operation. (In FAN mode only)

Notes on “INTELLIGENT EYE”

- Application range is as follows.

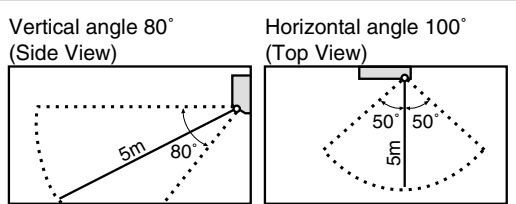

- Sensor may not detect moving objects further than 5m away. (Check the application range)
- Sensor detection sensitivity changes according to indoor unit location, the speed of passersby, temperature range, etc.
- The sensor also mistakenly detects pets, sunlight, fluttering curtains and light reflected off of mirrors as passersby.
- INTELLIGENT EYE operation will not go on during powerful operation.
- Night set mode (page 20.) will not go on during you use INTELLIGENT EYE operation.

⚠ CAUTION

- Do not place large objects near the sensor. Also keep heating units or humidifiers outside the sensor’s detection area. This sensor can detect objects it shouldn’t as well as not detect objects it should.
- Do not hit or violently push the INTELLIGENT EYE sensor. This can lead to damage and malfunction.

2.10 TIMER Operation

Timer functions are useful for automatically switching the air conditioner on or off at night or in the morning. You can also use OFF TIMER and ON TIMER in combination.

■ To use OFF TIMER operation

- Check that the clock is correct.
If not, set the clock to the present time.
(page 9.)

1. Press “OFF TIMER button”.

0:00 is displayed.

⊕-⊖ blinks.

2. Press “TIMER Setting button” until the time setting reaches the point you like.

- Every pressing of either button increases or decreases the time setting by 10 minutes. Holding down either button changes the setting rapidly.

3. Press “OFF TIMER button” again.

- The TIMER lamp lights up.

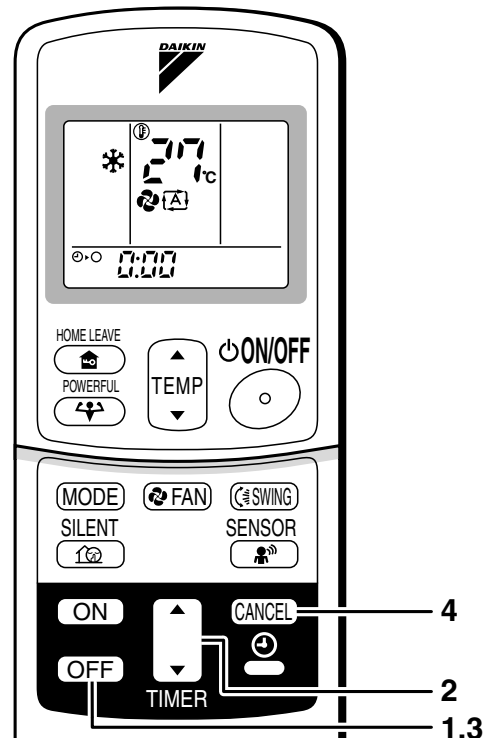

■ To cancel the OFF TIMER operation

4. Press “CANCEL button”.

- The TIMER lamp goes off.

Notes

- When TIMER is set, the present time is not displayed.
- Once you set ON, OFF TIMER, the time setting is kept in the memory. (The memory is canceled when remote controller batteries are replaced.)
- When operating the unit via the ON/OFF Timer, the actual length of operation may vary from the time entered by the user.

■ NIGHT SET MODE

When the OFF TIMER is set, the air conditioner automatically adjusts the temperature setting (0.5°C up in COOL, 2.0°C down in HEAT) to prevent excessive cooling (heating) for your pleasant sleep.

■ To use ON TIMER operation

- Check that the clock is correct. If not, set the clock to the present time (page 9.).

1. Press “ON TIMER button”.

7:00 is displayed.

⊕-| blinks.

2. Press “TIMER Setting button” until the time setting reaches the point you like.

- Every pressing of either button increases or decreases the time setting by 10 minutes. Holding down either button changes the setting rapidly.

3. Press “ON TIMER button” again.

- The TIMER lamp lights up.

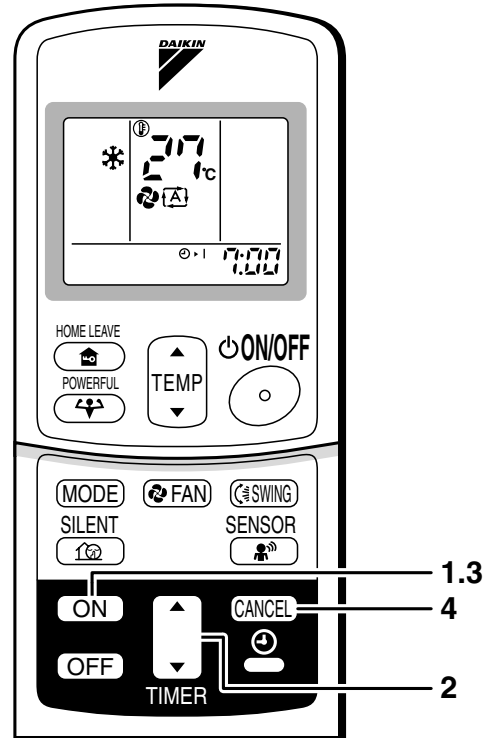

■ To cancel ON TIMER operation

4. Press “CANCEL button”.

- The TIMER lamp goes off.

■ To combine ON TIMER and OFF TIMER

- A sample setting for combining the two timers is shown below.

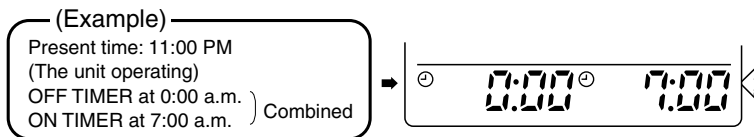

ATTENTION

■ In the following cases, set the timer again.

- After a breaker has turned OFF.
- After a power failure.
- After replacing batteries in the remote controller.

2.11 Care and Cleaning

 **CAUTION** Before cleaning, be sure to stop the operation and turn the breaker OFF.

Units

■ Indoor unit, Outdoor unit and Remote controller

1. Wipe them with dry soft cloth.

■ Front grille

1. Open the front grille.

- Hold the grille by the tabs on the two sides and lift it until it stops with a click.

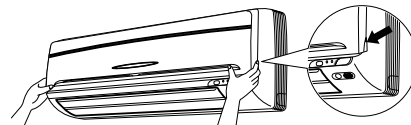

2. Remove the front grille.

- Supporting the front grille with one hand, release the lock by sliding down the knob with the other hand.
- To remove the front grille, pull it toward yourself with both hands.

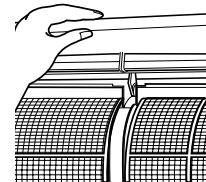

3. Clean the front grille

- Wipe it with a soft cloth soaked in water.
- Only neutral detergent may be used.
- In case of washing the grille with water, dry it with cloth, dry it up in the shade after washing.

4. Attach the front grille

- Set the 3 keys of the front grille into the slots and push them in all the way.
- Close the front grille slowly and push the grille at the 3 points.
(1 on each side and 1 in the middle.)
- Check to see if the rotating axis in the upper center section is moving.

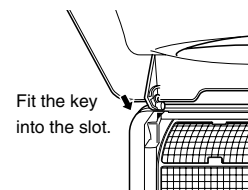

CAUTION

- Don't touch the metal parts of the indoor unit. If you touch those parts, this may cause an injury.
- When removing or attaching the front grille, use a robust and stable stool and watch your steps carefully.
- When removing or attaching the front grille, support the grille securely with hand to prevent it from falling.
- For cleaning, do not use hot water above 40 °C, benzene, gasoline, thinner, nor other volatile oils, polishing compound, scrubbing brushes, nor other hand stuff.
- After cleaning, make sure that the front grille is securely fixed.

Filters

1. **Open the front grille. (page 24)**
2. **Pull out the air filters.**
 - Push a little upwards the tab at the center of each air filter, then pull it down.

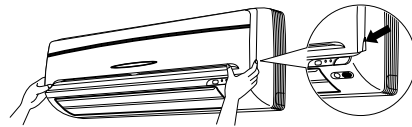

3. **Take off the air purifying filter with photocatalytic deodorizing function.**
 - Hold the recessed parts of the frame and unhook the four claws.

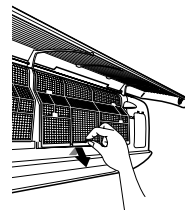

Air purifying filter with photocatalytic deodorizing function



4. **Clean or replace each filter.**
See below.

5. **Set the air filter, air purifying filter and photocatalytic deodorizing filter as they were and close the front grille.**
 - Insert claws of the filters into slots of the front grille. Close the front grille slowly and push the grille at the 3 points. (1 on each side and 1 in the middle.)

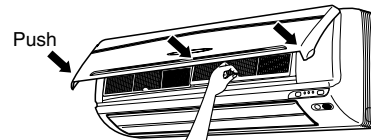

■ Air Filter

1. **Wash the air filters with water or clean them with vacuum cleaner.**
 - If the dust does not come off easily, wash them with neutral detergent thinned with lukewarm water, then dry them up in the shade.
 - It is recommended to clean the air filters every two weeks.

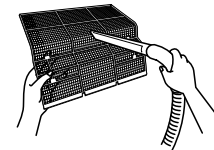

■ Air purifying filter with photocatalytic deodorizing function. (gray)

The Air purifying filter with photocatalytic deodorizing function can be renewed by washing it with water once every 6 months. We recommend replacing it once every 3 years.

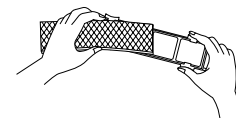

[Maintenance]

1. **Remove dust with a vacuum cleaner and wash lightly with water.**
2. **If it is very dirty, soak it for 10 to 15 minutes in water mixed with a neutral cleaning agent.**
3. **Do not remove filter from frame when washing with water.**
4. **After washing, shake off remaining water and dry in the shade.**
5. **Since the material is made out of paper, do not wring out the filter when removing water from it.**

[Replacement]

1. **Remove the tabs on the filter frame and replace with a new filter.**
 - Dispose of the old filter as flammable waste.

Check

Check that the base, stand and other fittings of the outdoor unit are not decayed or corroded.
Check that nothing blocks the air inlets and the outlets of the indoor unit and the outdoor unit.
Check that the earth wire is not disconnected or broken.
Check that the drain comes smoothly out of the drain hose during COOL or DRY operation. <ul style="list-style-type: none"> If no drain water is seen, water may be leaking from the indoor unit. Stop operation and consult the service shop if this is the case.

■ Before a long idle period

- 1. Operate the “fan only” for several hours on a fine day to dry out the inside.**
 - Press “MODE” button and select “fan” operation.
 - Press “ON/OFF” button and start operation.
- 2. Clean the air filters and set them again.**
- 3. Take out batteries from the remote controller.**
- 4. Turn OFF the breaker for the room air conditioner.**

NOTE

- Operation with dirty filters:
 - (1) cannot deodorize the air. (2) cannot clean the air.
 - (3) results in poor heating or cooling. (4) may cause odour.
- To order air purifying filter with photocatalytic deodorizing function contact to the service shop there you bought the air conditioner.
- Dispose of old filters as burnable waste.

Item	Part No.
Air purifying filter with photocatalytic deodorizing function. (without frame) 1 set	KAF918A44
Air purifying filter with photocatalytic deodorizing function. (with frame) 1 set	KAF918A43

2.12 Troubleshooting

These cases are not troubles.

The following cases are not air conditioner troubles but have some reasons. You may just continue using it.

Case	Explanation
<p>Operation does not start soon.</p> <ul style="list-style-type: none"> • When ON/OFF button was pressed soon after operation was stopped. • When the mode was reselected. 	<ul style="list-style-type: none"> • This is to protect the air conditioner. You should wait for about 3 minutes.
<p>Hot air does not flow out soon after the start of heating operation.</p>	<ul style="list-style-type: none"> • The air conditioner is warming up. You should wait for 1 to 4 minutes. (The system is designed to start discharging air only after it has reached a certain temperature.)
<p>The heating operation stops suddenly and a flowing sound is heard.</p>	<ul style="list-style-type: none"> • The system is taking away the frost on the outdoor unit. You should wait for about 3 to 8 minutes.
<p>The outdoor unit emits water or steam.</p>	<ul style="list-style-type: none"> ■ In HEAT mode <ul style="list-style-type: none"> • The frost on the outdoor unit melts into water or steam when the air conditioner is in defrost operation. ■ In COOL or DRY mode <ul style="list-style-type: none"> • Moisture in the air condenses into water on the cool surface of outdoor unit piping and drips.
<p>Mists come out of the indoor unit.</p>	<ul style="list-style-type: none"> ■ This happens when the air in the room is cooled into mist by the cold air flow during cooling operation.
<p>The indoor unit gives out odour.</p>	<ul style="list-style-type: none"> ■ This happens when smells of the room, furniture, or cigarettes are absorbed into the unit and discharged with the air flow. (If this happens, we recommend you to have the indoor unit washed by a technician. Consult the service shop where you bought the air conditioner.)
<p>The outdoor fan rotates while the air conditioner is not in operation.</p>	<ul style="list-style-type: none"> ■ After operation is stopped: <ul style="list-style-type: none"> • The outdoor fan continues rotating for another 60 seconds for system protection. ■ While the air conditioner is not in operation: <ul style="list-style-type: none"> • When the outdoor temperature is very high, the out door fan starts rotating for system protection.
<p>The operation stopped suddenly. (OPERATION lamp is on)</p>	<ul style="list-style-type: none"> ■ For system protection, the air conditioner may stop operating on a sudden large voltage fluctuation. It automatically resumes operation in about 3 minutes.

Check again.

Please check again before calling a repair person.

Case	Check
The air conditioner does not operate. (OPERATION lamp is off)	<ul style="list-style-type: none"> • Hasn't a breaker turned OFF or a fuse blown? • Isn't it a power failure? • Are batteries set in the remote controller? • Is the timer setting correct?
Cooling (Heating) effect is poor.	<ul style="list-style-type: none"> • Are the air filters clean? • Is there anything to block the air inlet or the outlet of the indoor and the outdoor units? • Is the temperature setting appropriate? • Are the windows and doors closed? • Are the air flow rate and the air direction set appropriately? • Is the unit set to the INTELLIGENT EYE mode? (page 18.)
Operation stops suddenly. (OPERATION lamp flashes.)	<ul style="list-style-type: none"> • Are the air filters clean? • Is there anything to block the air inlet or the outlet of the indoor and the outdoor units? Clean the air filters or take all obstacles away and turn the breaker OFF. Then turn it ON again and try operating the air conditioner with the remote controller. If the lamp still flashes, call the service shop where you bought the air conditioner.
An abnormal functioning happens during operation.	<ul style="list-style-type: none"> • The air conditioner may malfunction with lightning or radio waves. Turn the breaker OFF, turn it ON again and try operating the air conditioner with the remote controller.

Call the service shop immediately.

 **WARNING**

- When an abnormality (such as a burning smell) occurs, stop operation and turn the breaker OFF. Continued operation in an abnormal condition may result in troubles, electric shocks or fire. Consult the service shop where you bought the air conditioner.
- Do not attempt to repair or modify the air conditioner by yourself. Incorrect work may result in electric shocks or fire. Consult the service shop where you bought the air conditioner.

If one of the following symptoms takes place, call the service shop immediately.

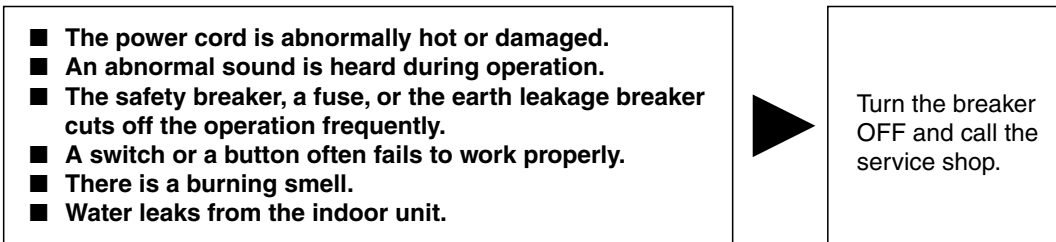

<ul style="list-style-type: none"> ■ After a power failure The air conditioner automatically resumes operation in about 3 minutes. You should just wait for a while. 	<ul style="list-style-type: none"> ■ Lightning If lightning may strike the neighbouring area, stop operation and turn the breaker OFF for system protection.
-----------------------------------------------------------------------------------------------------------------------------------------------------------------------------------------	---------------------------------------------------------------------------------------------------------------------------------------------------------------------------------

Disposal requirements

Dismantling of the unit, treatment of the refrigerant, oil and eventual other parts, should be done in accordance with the relevant local and national regulations.

We recommend periodical maintenance

In certain operating conditions, the inside of the air conditioner may get foul after several seasons of use, resulting in poor performance. It is recommended to have periodical maintenance by a specialist aside from regular cleaning by the user. For specialist maintenance, contact the service shop where you bought the air conditioner.

The maintenance cost must be born by the user.

Fault diagnosis

FAULT DIAGNOSIS BY REMOTE CONTROLLER

In the ARC433A series, the temperature display sections on the main unit indicate corresponding codes.

1. When the **TIMER CANCEL** button is held down for 5 seconds, a “**U0**” indication flashes on the temperature display section.

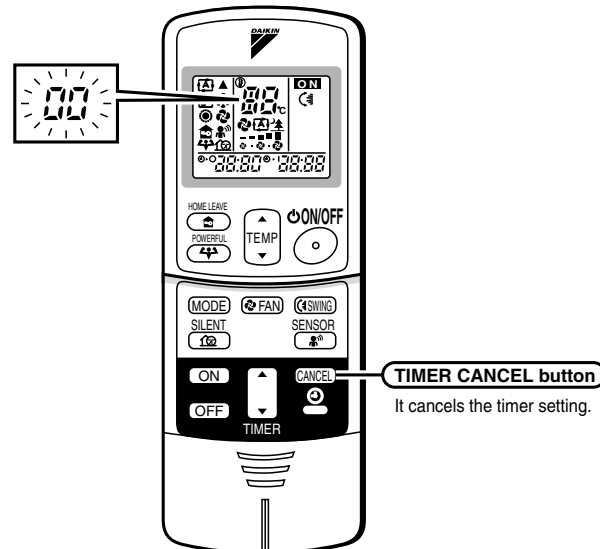

2. Press the **TIMER CANCEL** button repeatedly until a continuous beep is produced.

- The code indication changes in the sequence shown below, and notifies with along beep.

	CODE	MEANING
SYSTEM	00	NORMAL
	U0	REFRIGERANT SHORTAGE
	U2	DROP VOLTAGE OR MAIN CIRCUIT OVERVOLTAGE
	U4	FAILURE OF TRANSMISSION (BETWEEN INDOOR UNIT AND OUTDOOR UNIT)
INDOOR UNIT	A1	INDOOR PCB DEFECTIVENESS
	A5	HIGH PRESSURE CONTROL OR FREEZE-UP PROTECTOR
	A6	FAN MOTOR FAULT
	C4	FAULTY HEAT EXCHANGER TEMPERATURE SENSOR
	C9	FAULTY SUCTION AIR TEMPERATURE SENSOR
OUTDOOR UNIT	EA	COOLING-HEATING SWITCHING ERROR
	E5	OL STARTED
	E6	FAULTY COMPRESSOR START UP
	E7	DC FAN MOTOR FAULT
	E8	OPERATION HALT DUE TO DETECTION OF INPUT OVER CURRENT
	F3	HIGH TEMPERATURE DISCHARGE PIPE CONTROL
	F6	HIGH PRESSURE CONTROL (IN COOLING)
	H6	OPERATION HALT DUE TO FAULTY POSITION DETECTION SENSOR
	H8	CT ABNORMALITY
	H9	FAULTY SUCTION AIR TEMPERATURE SENSOR
	J3	FAULTY DISCHARGE PIPE TEMPERATURE SENSOR
	J6	FAULTY HEAT EXCHANGER TEMPERATURE SENSOR
	L4	HIGH TEMPERATURE AT INVERTER CIRCUIT HEATSINK
	L5	OUTPUT OVERCURRENT
P4	FAULTY INVERTER CIRCUIT HEATSINK TEMPERATURE SENSOR	

NOTE

1. A short beep and two consecutive beeps indicate non-corresponding codes.
2. To cancel the code display, hold the **TIMER CANCEL** button down for 5 seconds. The code display also cancel itself if the button is not pressed for 1 minute.

Part 6

Service Diagnosis

1. Caution for Diagnosis.....	90
2. Problem Symptoms and Measures	91
3. Service Check Function	92
4. Troubleshooting	95
4.1 Error Codes and Description	95
4.2 Indoor Unit PCB Abnormality	96
4.3 Freeze-up Protection Control or High Pressure Control.....	97
4.4 Fan Motor (AC Motor) or Related Abnormality.....	99
4.5 Thermistor or Related Abnormality (Indoor Unit).....	100
4.6 Signal Transmission Error (between Indoor and Outdoor Unit)	101
4.7 OL Activation (Compressor Overload)	102
4.8 Compressor Lock	103
4.9 DC Fan Lock	104
4.10 Input Over Current Detection	105
4.11 Four Way Valve Abnormality	106
4.12 Discharge Pipe Temperature Control.....	108
4.13 High Pressure Control in Cooling	109
4.14 Position Sensor Abnormality	111
4.15 DC Voltage / Current Sensor Abnormality.....	112
4.16 Thermistor or Related Abnormality (Outdoor Unit).....	113
4.17 Electrical Box Temperature Rise.....	115
4.18 Radiation Fin Temperature Rise	117
4.19 Output Over Current Detection.....	119
4.20 Insufficient Gas.....	121
4.21 Over-voltage Detection.....	123
5. Check	124
5.1 How to Check.....	124

1. Caution for Diagnosis

The operation lamp flashes when any of the following errors is detected.

1. When a protection device of the indoor or outdoor unit is activated or when the thermistor malfunctions, disabling equipment operation.
 2. When a signal transmission error occurs between the indoor and outdoor units.
- In either case, conduct the diagnostic procedure described in the following pages.

Location of Operation Lamp

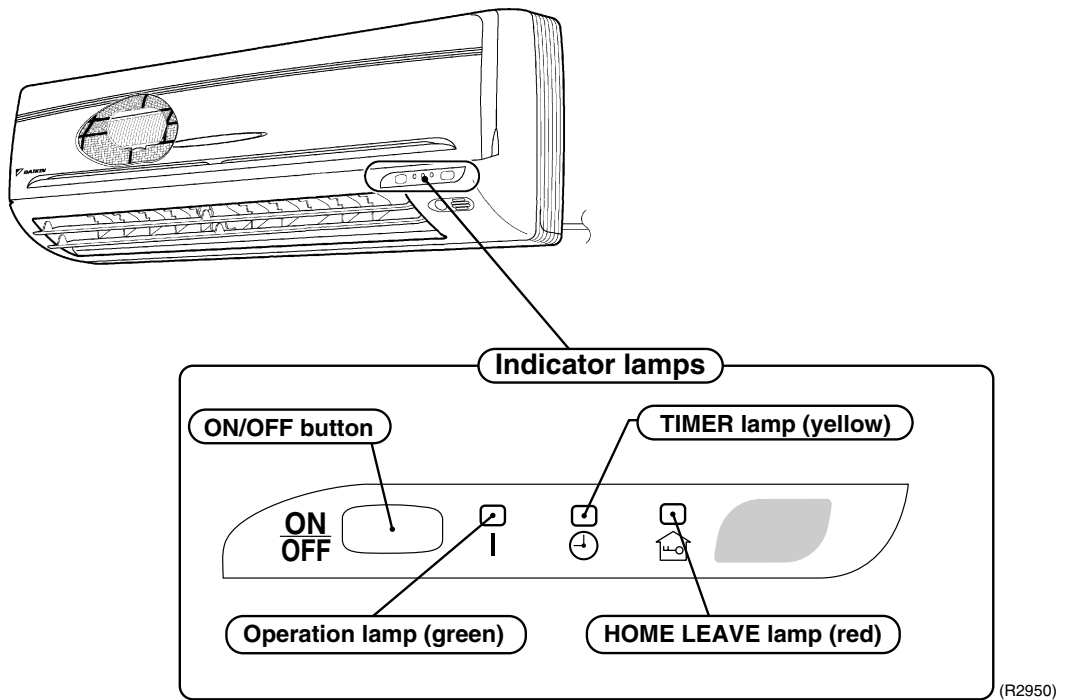

Troubleshooting with LED Indication

The outdoor unit has one green LED (LEDA) on the PCB. The flashing green LED indicates normal condition of microcomputer operation.

2. Problem Symptoms and Measures

Symptom	Check Item	Details of Measure	Reference Page
None of the Units Operates.	Check the power supply.	Check to make sure that the rated voltage is supplied.	—
	Check the type of the indoor units.	Check to make sure that the indoor unit type is compatible with the outdoor unit.	—
	Check the outdoor air temperature.	Heating operation cannot be used when the outdoor air temperature is 21°C or higher (only for heat pump model), and cooling operation cannot be used when the outdoor air temperature is below 10°C. (Note)	—
	Diagnosis with remote controller indication	—	95
	Check the remote controller addresses.	Check to make sure that address settings for the remote controller and indoor unit are correct.	—
Operation Sometimes Stops.	Check the power supply.	A power failure of 2 to 10 cycles can stop air conditioner operation. (Operation lamp OFF)	—
	Check the outdoor air temperature.	Heating operation cannot be used when the outdoor air temperature is 24°C or higher (only for heat pump model), and cooling operation cannot be used when the outdoor air temperature is below 10°C. (Note)	—
	Diagnosis with remote controller indication	—	95
Equipment operates but does not cool, or does not heat (only for heat pump model).	Check for wiring and piping errors in the indoor and outdoor units connection wires and pipes.	Conduct the wiring/piping error check described on the product diagnosis nameplate.	—
	Check for thermistor detection errors.	Check to make sure that the main unit's thermistor has not dismantled from the pipe holder.	—
	Check for faulty operation of the electronic expansion valve.	Set the units to cooling operation, and compare the temperatures of the liquid side connection pipes of the connection section among rooms to check the opening and closing operation of the electronic expansion valves of the individual units.	—
	Diagnosis with remote controller indication	—	95
	Diagnosis by service port pressure and operating current	Check for insufficient gas.	129
Large Operating Noise and Vibrations	Check the output voltage of the power transistor.	—	130
	Check the power transistor.	—	—
	Check the installation condition.	Check to make sure that the required spaces for installation (specified in the Technical Guide, etc.) are provided.	—



Note: RK(X)S, ARK(X)S series ; -10°C

3. Service Check Function

In the **ARC433A** series remote controller, the temperature display sections on the main unit indicate corresponding codes.

Check Method 1

1. When the timer cancel button is held down for 5 seconds, a “00” indication flashes on the temperature display section.

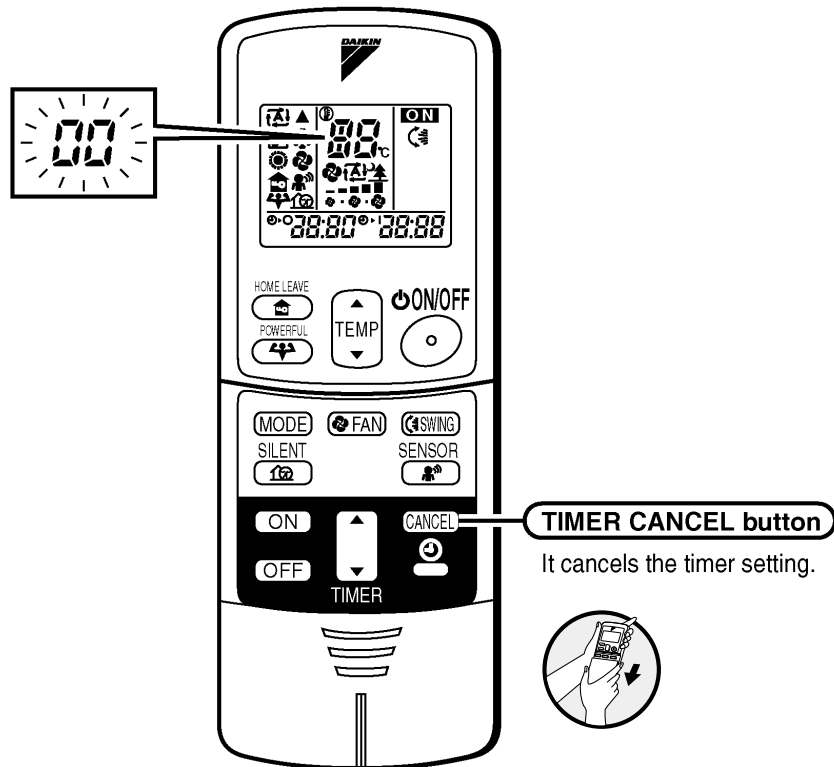

< ARC433A1, A2 >

(R3038)

2. Press the timer cancel button repeatedly until a continuous beep is produced.
 - The code indication changes in the sequence shown below, and notifies with a long beep.

No.	Code	No.	Code	No.	Code
1	00	11	E7	21	UR
2	U4	12	C7	22	R5
3	F3	13	H8	23	J9
4	E6	14	J3	24	E8
5	L5	15	R3	25	P4
6	R6	16	R1	26	L3
7	E5	17	C4	27	L4
8	LC	18	C5	28	H6
9	C9	19	H9	29	H7
10	U0	20	J6	30	U2



Note:

1. A short beep and two consecutive beeps indicate non-corresponding codes.
2. To cancel the code display, hold the timer cancel button down for 5 seconds. The code display also cancels itself if the button is not pressed for 1 minute.

Check Method 2

1. Enter the diagnosis mode.
Press the 3 buttons (TEMP▲,TEMP▼, MODE) simultaneously.

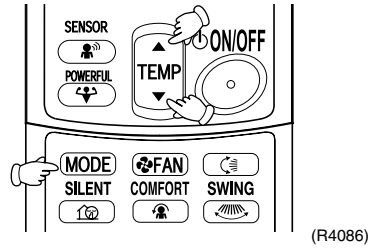

The digit of the number of tens blinks.

★Try again from the start when the digit does not blink.

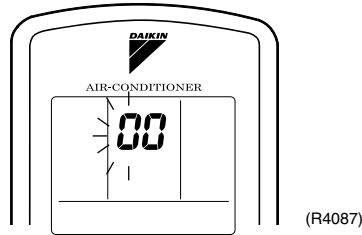

2. Press the TEMP button.
Press TEMP▲ or TEMP▼ and change the digit until you hear the sound of “beep” or “pi pi”.

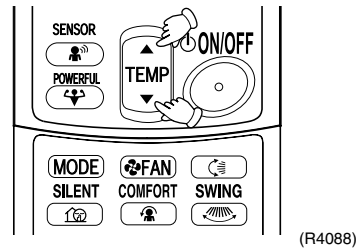

3. Diagnose by the sound.
 - ★“ pi ” : The number of tens does not accord with the error code.
 - ★“ pi pi ” : The number of tens accords with the error code.
 - ★“ beep ” : The both numbers of tens and units accord with the error code. (→See 7.)

4. Enter the diagnosis mode again.
Press the MODE button.

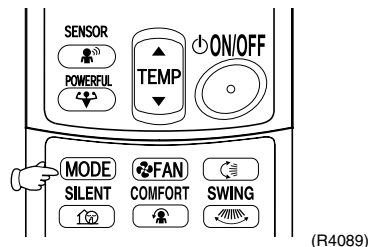

The digit of the number of units blinks.

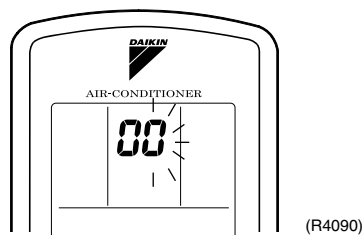

5. Press the TEMP button.
Press TEMP▲ or TEMP▼ and change the digit until you hear the sound of “beep”.

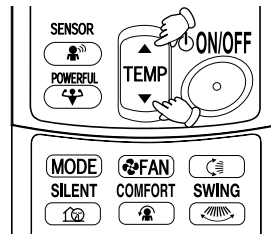

(R4088)

6. Diagnose by the sound.
 - ★“ pi ” : The both numbers of tens and units do not accord with the error code.
 - ★“ pi pi ” : The number of tens accords with the error code.
 - ★“ beep ” : The both numbers of tens and units accord with the error code.
7. Determine the error code.
The digits indicated when you hear the “beep” sound are error code.
(Error codes and description → Refer to page 95.)
8. Exit from the diagnosis mode.
Press the MODE button.

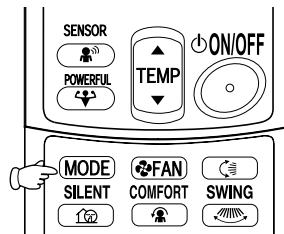

(R4089)

4. Troubleshooting

4.1 Error Codes and Description

	Code Indication	Description	Reference Page
System	<i>00</i>	Normal	—
	<i>U0</i> ★	Insufficient gas	121
	<i>U2</i>	Over-voltage detection	123
	<i>U4</i>	Signal transmission error (between indoor and outdoor unit)	101
Indoor Unit	<i>R1</i>	Indoor unit PCB abnormality	96
	<i>R5</i>	Freeze-up protection control or high pressure control	97
	<i>R6</i>	Fan motor or related abnormality	99
	<i>C4</i>	Heat exchanger temperature thermistor abnormality	100
	<i>C9</i>	Room temperature thermistor abnormality	100
Outdoor Unit	<i>E5</i> ★	OL activation (compressor overload)	102
	<i>E6</i> ★	Compressor lock	103
	<i>E7</i>	DC fan lock	104
	<i>E8</i>	Input over current detection	105
	<i>ER</i>	Four way valve abnormality	106
	<i>F3</i>	Discharge pipe temperature control	108
	<i>F6</i>	High pressure control in cooling	109
	<i>H5</i>	Position sensor abnormality	111
	<i>H8</i>	DC voltage/current sensor abnormality	112
	<i>H9</i>	Outdoor air thermistor or related abnormality	113
	<i>J3</i>	Discharge pipe temperature thermistor or related abnormality	113
	<i>J5</i>	Heat exchanger temperature thermistor or related abnormality	113
	<i>L3</i>	Electrical box temperature rise	115
	<i>L4</i>	Radiation fin temperature rise	117
	<i>L5</i>	Output over current detection	119
	<i>P4</i>	Heat radiation fin thermistor or related abnormality	113

★: Displayed only when system-down occurs.

4.2 Indoor Unit PCB Abnormality

Remote
Controller
Display

A1

Method of
Malfunction
Detection

Evaluation of zero-cross detection of power supply by indoor unit.

Malfunction
Decision
Conditions

When there is no zero-cross detection in approximately 10 continuous seconds.

Supposed
Causes

- Faulty indoor unit PCB
- Faulty connector connection

Troubleshooting



Caution

Be sure to turn off power switch before connect or disconnect connector, or parts damage may be occurred.

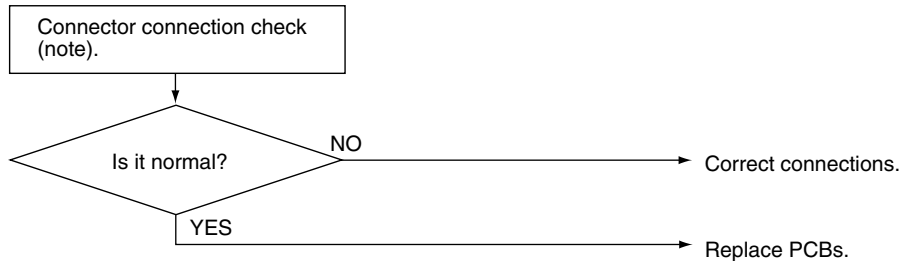

(R1400)



Note: Connector Nos. vary depending on models.

Model Type	Connector No.
Wall Mounted Type 20 / 25 / 35 class	Terminal strip~Control PCB

4.3 Freeze-up Protection Control or High Pressure Control

Remote
Controller
Display

AS

Method of
Malfunction
Detection

- High pressure control (heat pump model only)
During heating operations, the temperature detected by the indoor heat exchanger thermistor is used for the high pressure control (stop, outdoor fan stop, etc.)
- Freeze-up protection control (operation halt) is activated during cooling operation according to the temperature detected by the indoor unit heat exchanger thermistor.

Malfunction
Decision
Conditions

- High pressure control
During heating operations, the temperature detected by the indoor heat exchanger thermistor is above 65°C
- Freeze-up protection

When the indoor unit heat exchanger temperature is below 0°C during cooling operation.

Supposed
Causes

- Operation halt due to clogged air filter of the indoor unit.
- Operation halt due to dust accumulation on the indoor unit heat exchanger.
- Operation halt due to short-circuit.
- Detection error due to faulty indoor unit heat exchanger thermistor.
- Detection error due to faulty indoor unit PCB.

Troubleshooting



Check No.6
Refer to P.126



Caution Be sure to turn off power switch before connect or disconnect connector, or parts damage may be occurred.

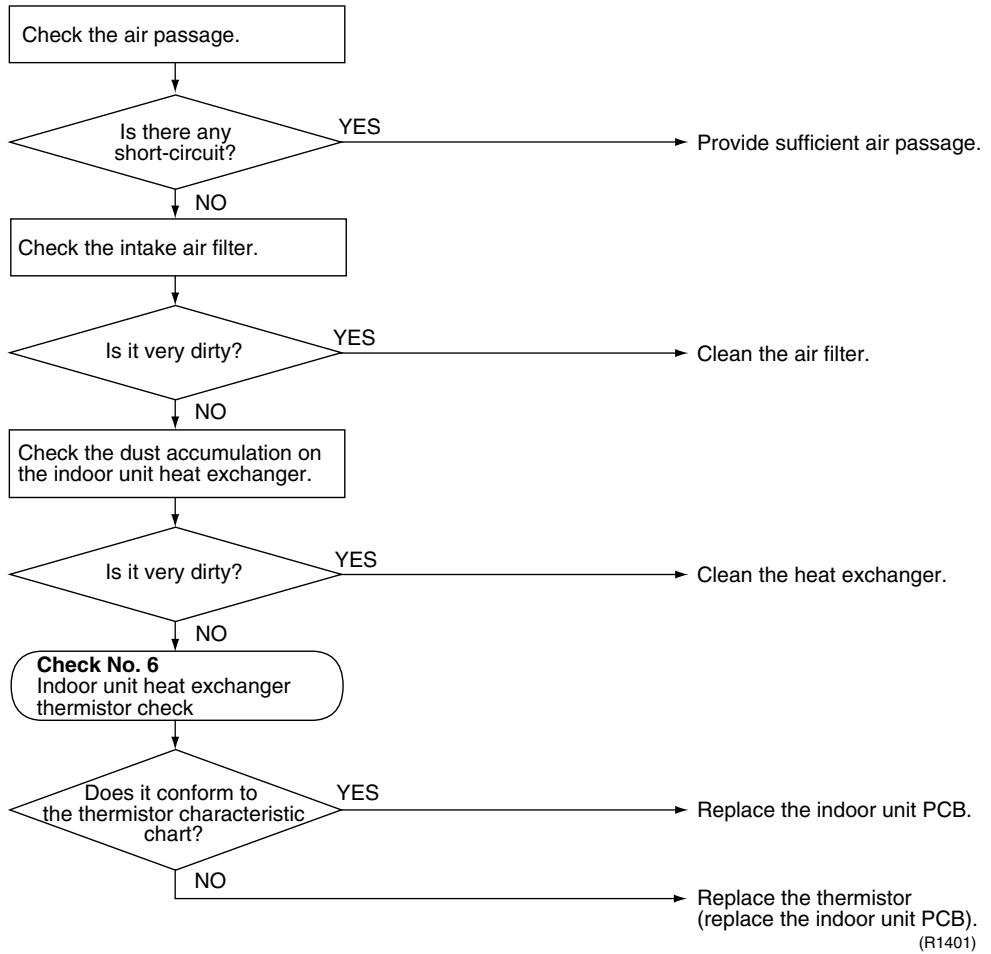

4.4 Fan Motor (AC Motor) or Related Abnormality

Remote
Controller
Display

AB

Method of
Malfunction
Detection

The rotation speed detected by the Hall IC during fan motor operation is used to determine abnormal fan motor operation.

Malfunction
Decision
Conditions

When the detected rotation speed is less than 50% of the HH tap under maximum fan motor rotation demand.

Supposed
Causes

- Operation halt due to short circuit inside the fan motor winding.
- Operation halt due to breaking of wire inside the fan motor.
- Operation halt due to breaking of the fan motor lead wires.
- Operation halt due to faulty capacitor of the fan motor.
- Detection error due to faulty indoor unit PCB.

Troubleshooting



Check No.16
Refer to P.131

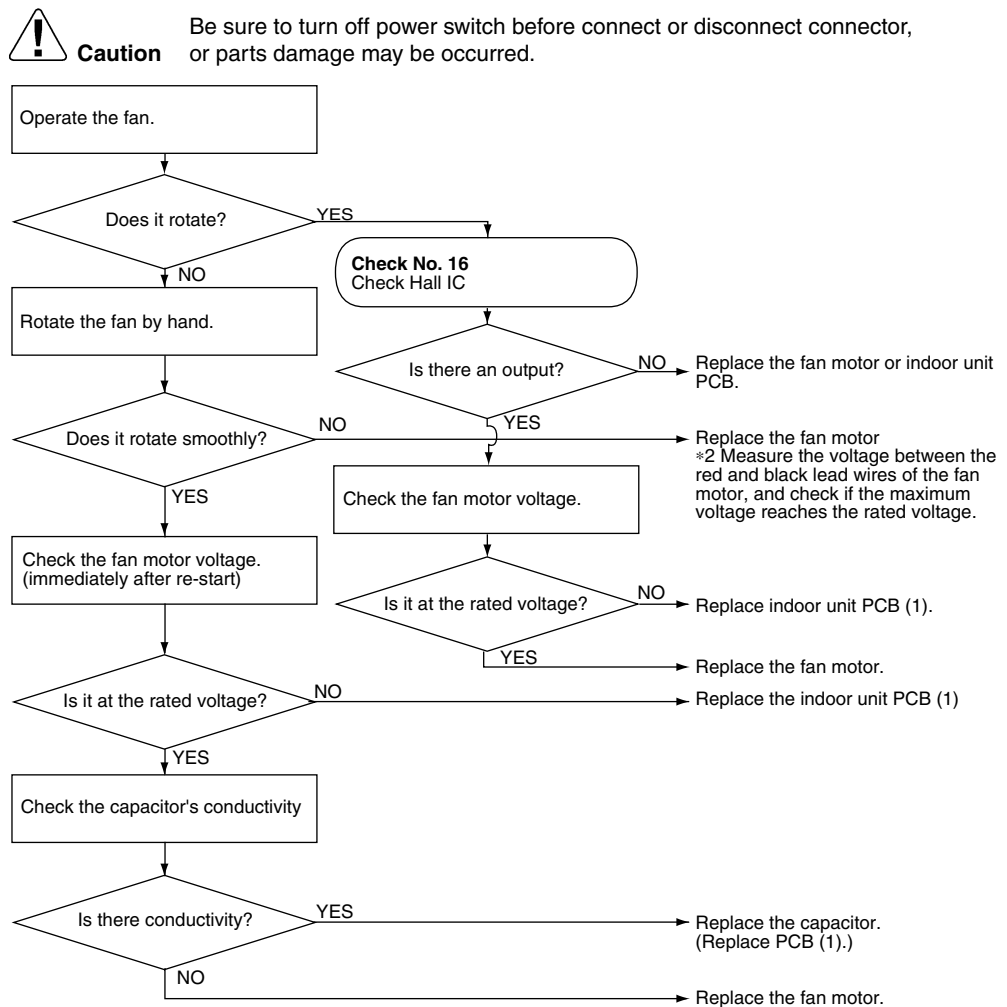

(R4096)

4.5 Thermistor or Related Abnormality (Indoor Unit)

Remote
Controller
Display

C4, C9

Method of
Malfunction
Detection

The temperatures detected by the thermistors are used to determine thermistor errors.

Malfunction
Decision
Conditions

When the thermistor input is more than 4.96 V or less than 0.04 V during compressor operation*.
* (reference)
When above about 212°C (less than 120 ohms) or below about -50°C (more than 1,860 kohms).



Note: The values vary slightly in some models.

Supposed
Causes

- Faulty connector connection
- Faulty thermistor
- Faulty PCB

Troubleshooting



Check No.6
Refer to P.126



Caution

Be sure to turn off power switch before connect or disconnect connector, or parts damage may be occurred.

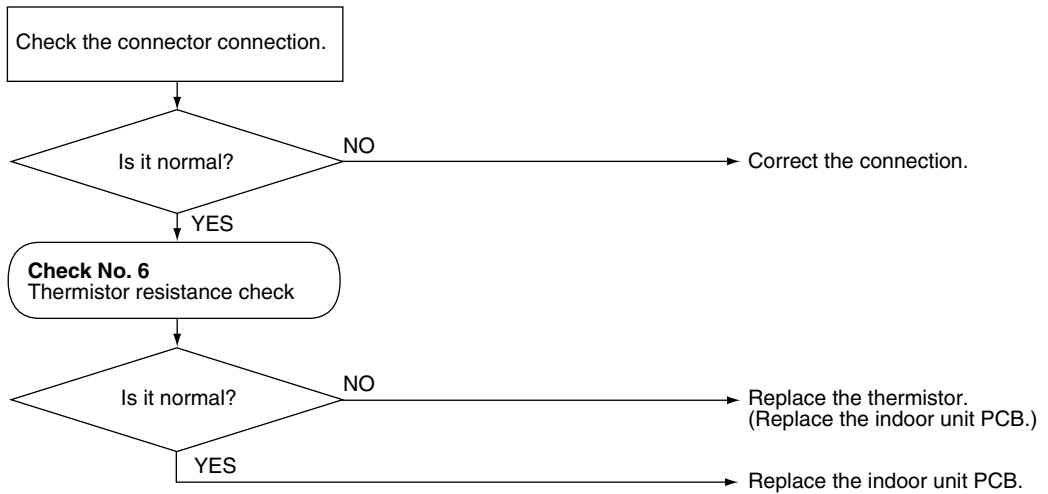

C4 : Room temperature thermistor
C9 : Room temperature thermistor

(R1403)

4.6 Signal Transmission Error (between Indoor and Outdoor Unit)

Remote
Controller
Display

U4

Method of
Malfunction
Detection

The data received from the outdoor unit in indoor unit-outdoor unit signal transmission is checked whether it is normal.

Malfunction
Decision
Conditions

When the data sent from the outdoor unit cannot be received normally, or when the content of the data is abnormal.

Supposed
Causes

- Faulty outdoor unit PCB.
- Faulty indoor unit PCB.
- Indoor unit-outdoor unit signal transmission error due to wiring error.
- Indoor unit-outdoor unit signal transmission error due to disturbed power supply waveform.
- Indoor unit-outdoor unit signal transmission error due to breaking of wire in the connection wires between the indoor and outdoor units (wire No. 2).

Troubleshooting



Check No.10
Refer to P.129

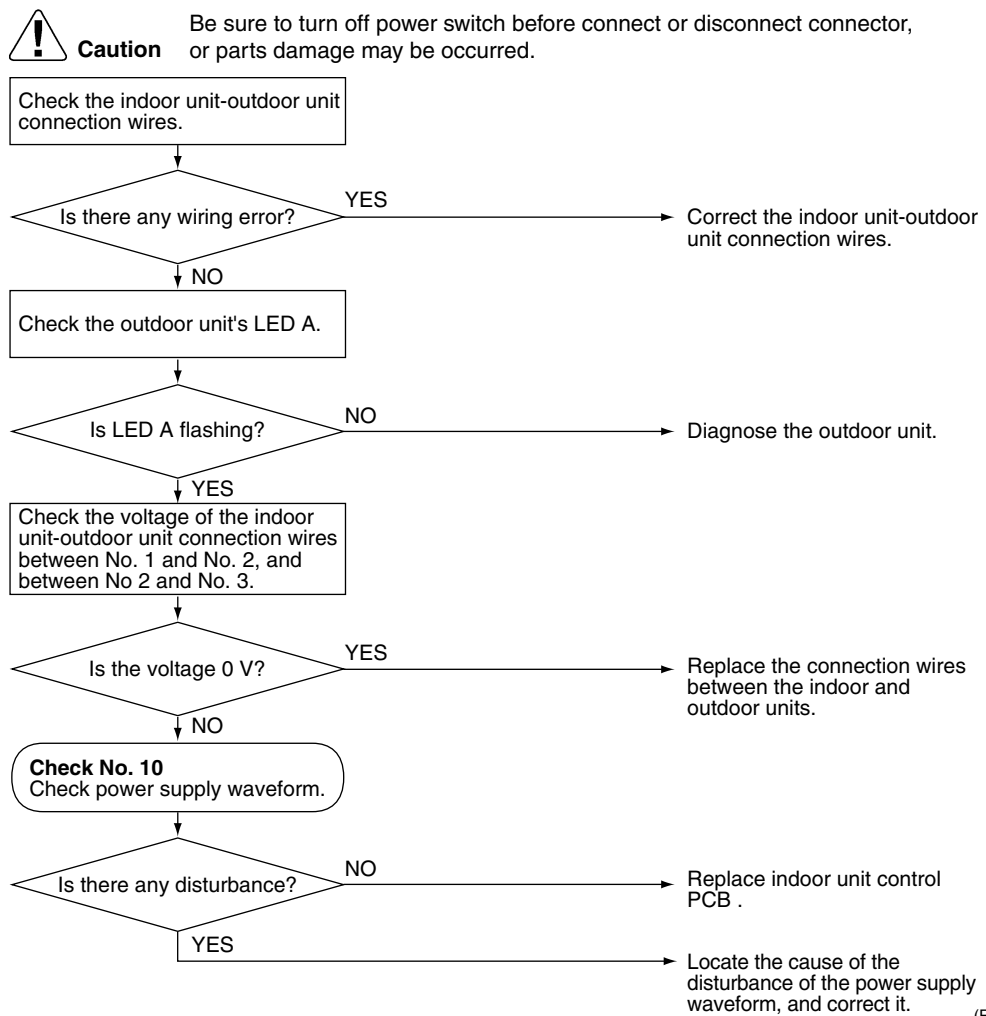

4.7 OL Activation (Compressor Overload)

Remote
Controller
Display

ES

Method of
Malfunction
Detection

A compressor overload is detected through compressor OL.

Malfunction
Decision
Conditions

- If the compressor OL is activated twice, the system will be shut down.
 - The error counter will reset itself if this or any other error does not occur during the following 60-minute compressor running time (total time).
- * The operating temperature condition is not specified.

Supposed
Causes

- Refrigerant shortage
- Four way valve malfunctioning
- Outdoor unit PCB defective
- Water mixed in the local piping
- Electronic expansion valve defective
- Stop valve defective

Troubleshooting

Check No.4
Refer to P.124

Check No.5
Refer to P.125



Check No.6
Refer to P.126

Check No.11
Refer to P.129

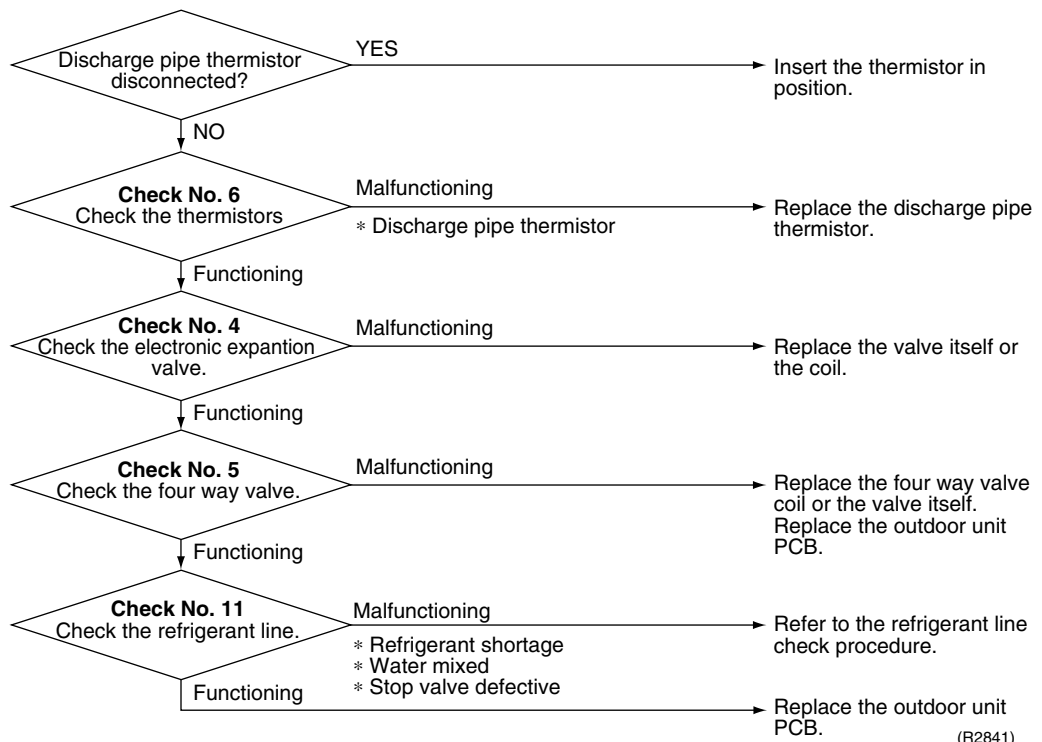

Caution

Be sure to turn off power switch before connect or disconnect connector, or parts damage may be occurred.



4.8 Compressor Lock

Remote
Controller
Display

EG

Method of
Malfunction
Detection

A compressor lock is detected by checking the compressor running condition through the position detection circuit.

Malfunction
Decision
Conditions

- The system judges the compressor lock, and stops due to over current.
- The system judges the compressor lock, and cannot operation with position detection within 15 seconds after start up.
- The system will be shut down if the error occurs 16 times.
- Clearing condition: Continuous run for about 10 minutes (normal)

Supposed
Causes

- Compressor locked
- Compressor harness disconnected

Troubleshooting

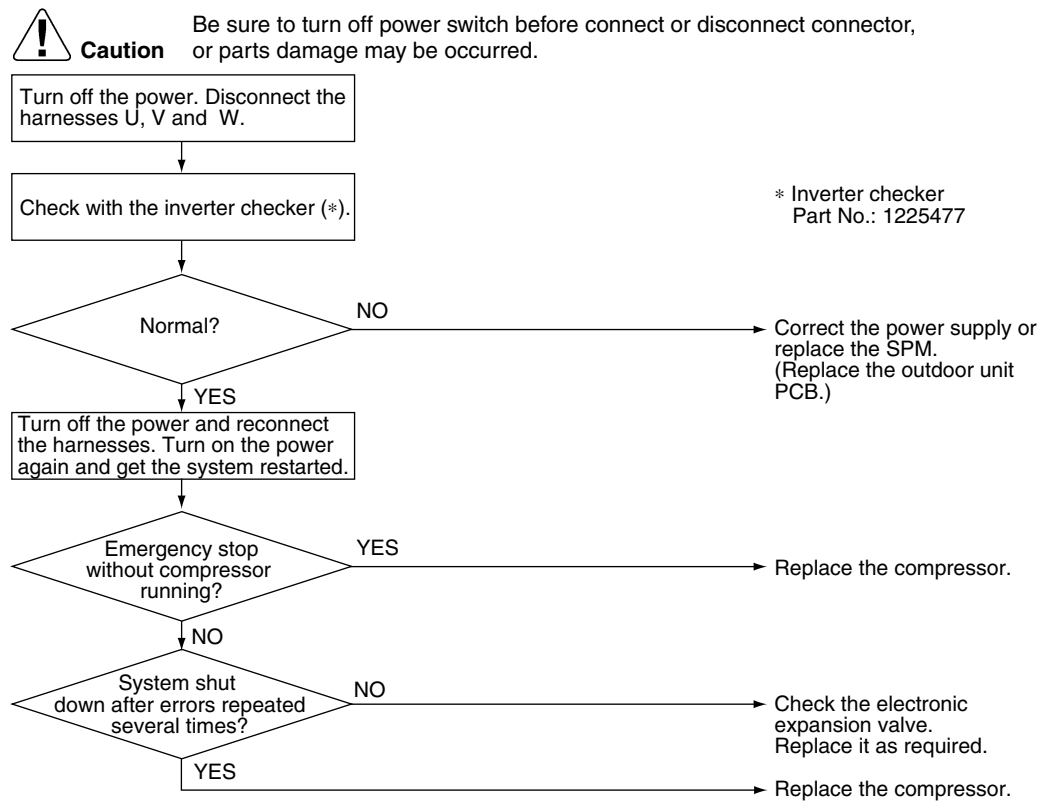

Note: If the model doesn't have SPM, replace the outdoor unit PCB.

(R2842)

4.9 DC Fan Lock

Remote
Controller
Display

E7

Method of
Malfunction
Detection

A fan motor or related error is detected by checking the high-voltage fan motor rpm being detected by the Hall IC.

Malfunction
Decision
Conditions

- The fan does not start in 30 seconds even when the fan motor is running.
- The system will be shut down if the error occurs 16 times.
- Clearing condition: Continuous run for about 5 minutes (normal)

Supposed
Causes

- Fan motor breakdown
- Harness or connector disconnected between fan motor and PCB or in poor contact
- Foreign matters stuck in the fan

Troubleshooting

Check No.15
Refer to P.130

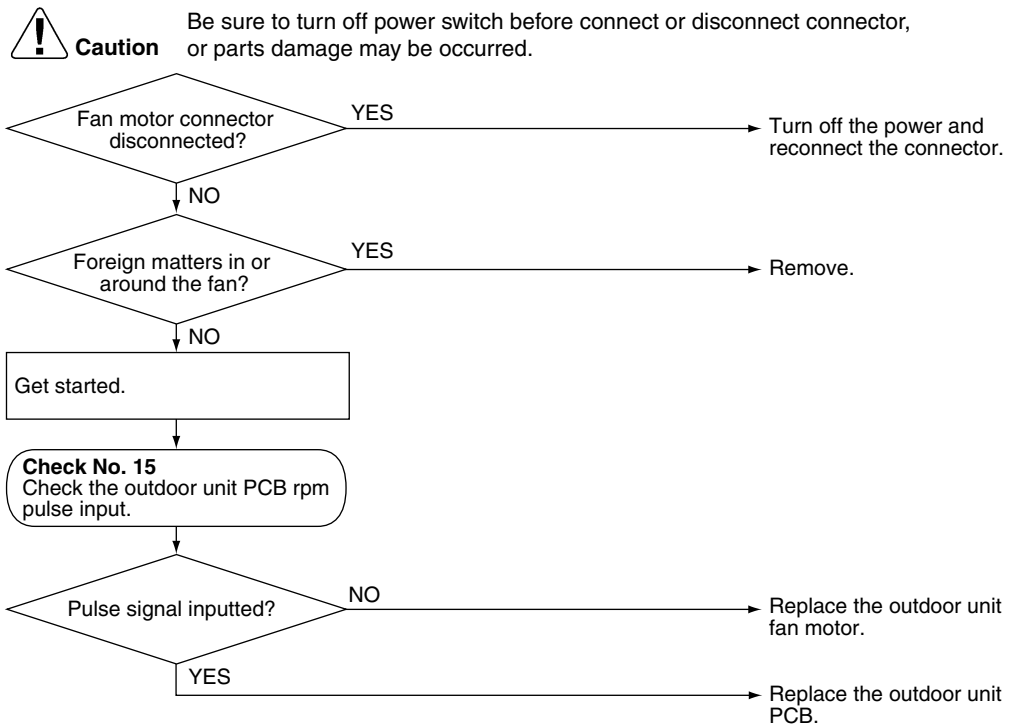

(R2843)

4.10 Input Over Current Detection

Remote
Controller
Display

EB

Method of
Malfunction
Detection

An input over-current is detected by checking the input current value with the compressor running.

Malfunction
Decision
Conditions

- The following current with the compressor running continues for 2.5 seconds.
Cooling·Heating: Above 12A

Supposed
Causes

- Over-current due to compressor failure
- Over-current due to defective power transistor
- Over-current due to defective outdoor unit PCB
- Error detection due to outdoor unit PCB
- Over-current due to short-circuit

Troubleshooting

Check No.7
Refer to P.127



Check No.8
Refer to P.127



Caution

Be sure to turn off power switch before connect or disconnect connector, or parts damage may be occurred.

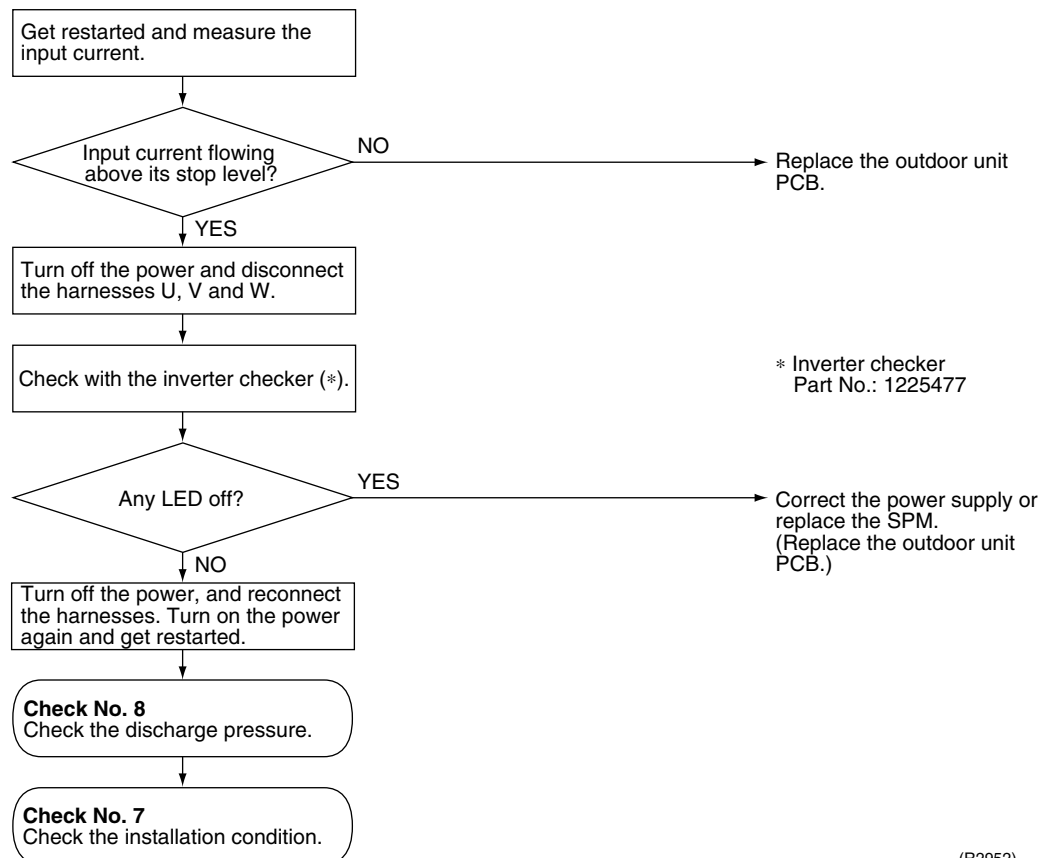
* An input over-current may result from wrong internal wiring. If the wires have been disconnected and reconnected for part replacement, for example, and the system is interrupted by an input over-current, take the following procedure.



(R2952)



Note: If the model doesn't have SPM, replace the outdoor unit PCB.

4.11 Four Way Valve Abnormality

**Remote
Controller
Display**

ER

**Method of
Malfunction
Detection**

The indoor air temperature thermistor, the indoor unit heat exchanger thermistor, the outdoor temperature thermistor and the outdoor unit heat exchanger thermistor are checked to see if they function within their normal ranges in the operating mode.

**Malfunction
Decision
Conditions**

A following condition continues over 10 minute after operating 5 minutes.

- Cooling / dry operation
(room temp. – indoor heat exchanger temp.) < -5°C
- Heating
(indoor unit heat exchanger temp. – room temp.) < -5°C

**Supposed
Causes**

- Connector in poor contact
- Thermistor defective
- Outdoor unit PCB defective
- Four way valve coil or harness defective
- Four way valve defective
- Foreign substance mixed in refrigerant
- Insufficient gas

Troubleshooting

 **Check No.5**
Refer to P.125

 **Check No.6**
Refer to P.126

 **Check No.11**
Refer to P.129



Caution Be sure to turn off power switch before connect or disconnect connector, or parts damage may be occurred.

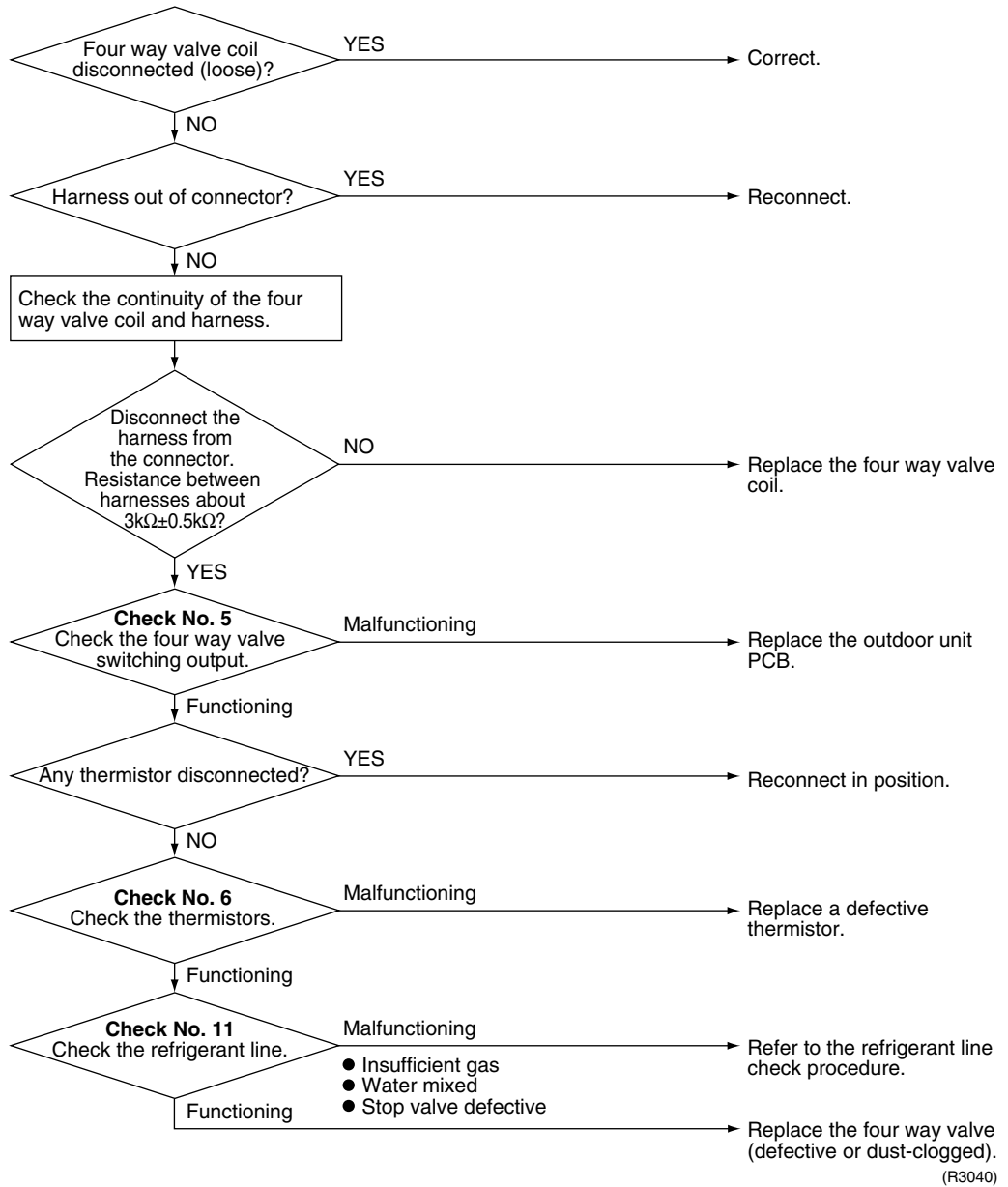

4.12 Discharge Pipe Temperature Control

Remote
Controller
Display



Method of
Malfunction
Detection

The discharge pipe temperature control (stop, frequency drooping, etc.) is checked with the temperature being detected by the discharge pipe thermistor.

Malfunction
Decision
Conditions

- If a stop takes place 4 times successively due to abnormal discharge pipe temperature, the system will be shut down.
- If the temperature being detected by the discharge pipe thermistor rises above A°C , the compressor will stop. (The error is cleared when the temperature has dropped below B°C .)

Stop temperatures	A	B	
		(A)RK(X)S	(A)RK(X)H, R(Y)N
(1) above 45Hz (rising), above 40Hz (dropping)	110	97	85
(2) 30~45Hz (rising), 25~40Hz (dropping)	105	92	80
(3) below 30Hz (rising), below 25Hz (dropping)	99	86	74

- The error counter will reset itself if this or any other error does not occur during the following 60-minute compressor running time (total time).

Supposed
Causes

- Refrigerant shortage
- Four way valve malfunctioning
- Discharge pipe thermistor defective (heat exchanger or outdoor air temperature thermistor defective)
- Outdoor unit PCB defective
- Water mixed in the local piping
- Electronic expansion valve defective
- Stop valve defective

Troubleshooting

Check No.4
Refer to P.124

Check No.6
Refer to P.126

Check No.11
Refer to P.129

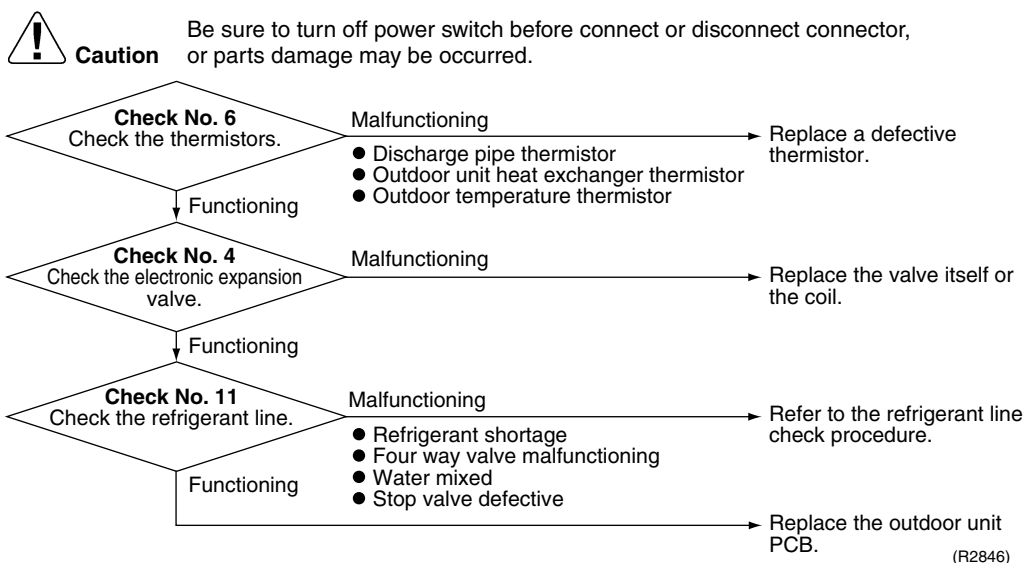

4.13 High Pressure Control in Cooling

Remote
Controller
Display

FB

Method of
Malfunction
Detection

High-pressure control (stop, frequency drop, etc.) is activated in the cooling mode if the temperature being sensed by the heat exchanger thermistor exceeds the limit.

Malfunction
Decision
Conditions

Activated when the temperature being sensed by the heat exchanger thermistor rises above 65°C. (The error is cleared when the temperature drops below 54°C.)

Supposed
Causes

- The installation space is not large enough.
- Faulty outdoor unit fan
- Faulty electronic expansion valve
- Faulty defrost thermistor
- Faulty outdoor unit PCB
- Faulty stop valve
- Dirty heat exchanger

Troubleshooting

Check No.4
 Refer to P.124

Check No.6
 Refer to P.126

Check No.7
 Refer to P.127

Check No.9
 Refer to P.128

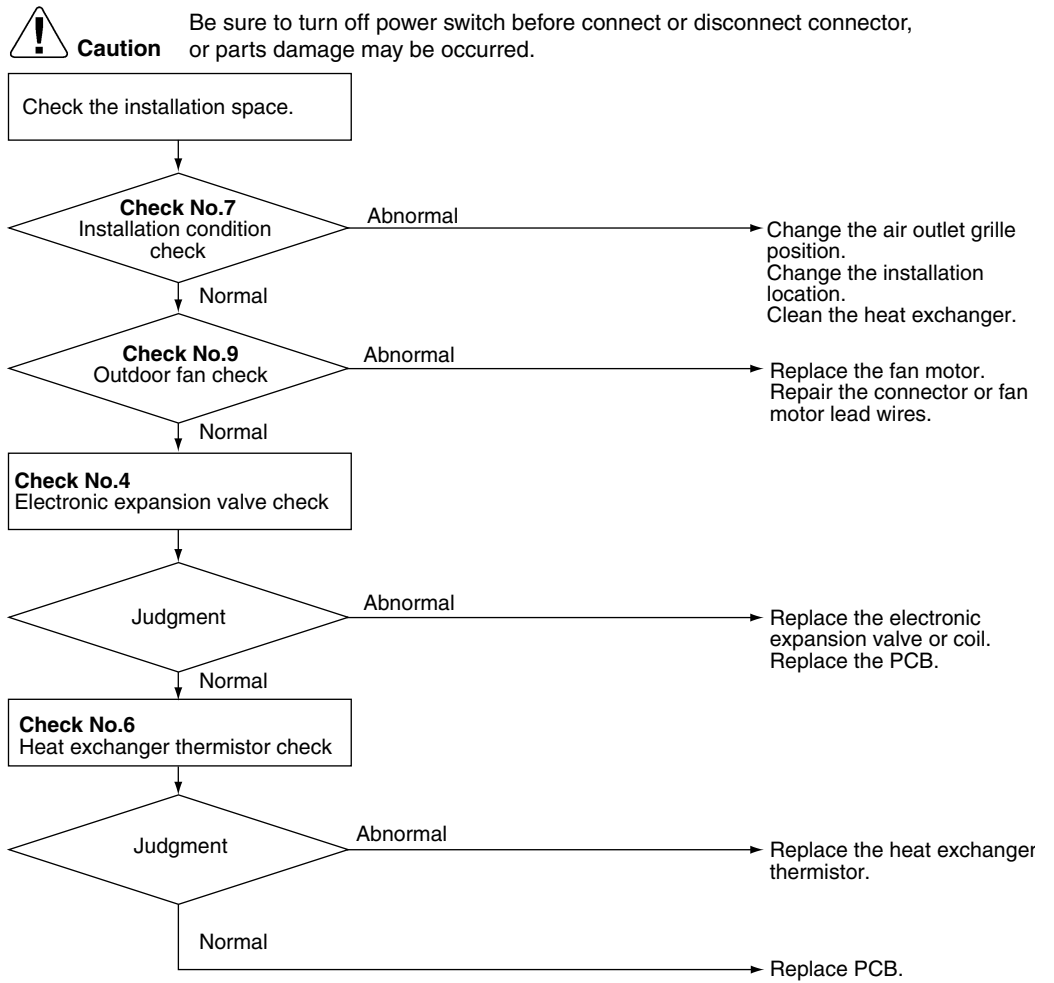

(R2855)

4.14 Position Sensor Abnormality

Remote
Controller
Display

46

Method of
Malfunction
Detection

A compressor startup failure is detected by checking the compressor running condition through the position detection circuit.

Malfunction
Decision
Conditions

- The compressor fails to start in about 15 seconds after the compressor run command signal is sent.
- Clearing condition: Continuous run for about 10 minutes (normal)
- The system will be shut down if the error occurs 16 times.

Supposed
Causes

- Compressor relay cable disconnected
- Compressor itself defective
- Outdoor unit PCB defective
- Stop valve closed
- Input voltage out of specification

Troubleshooting



Check No.13
Refer to P.130

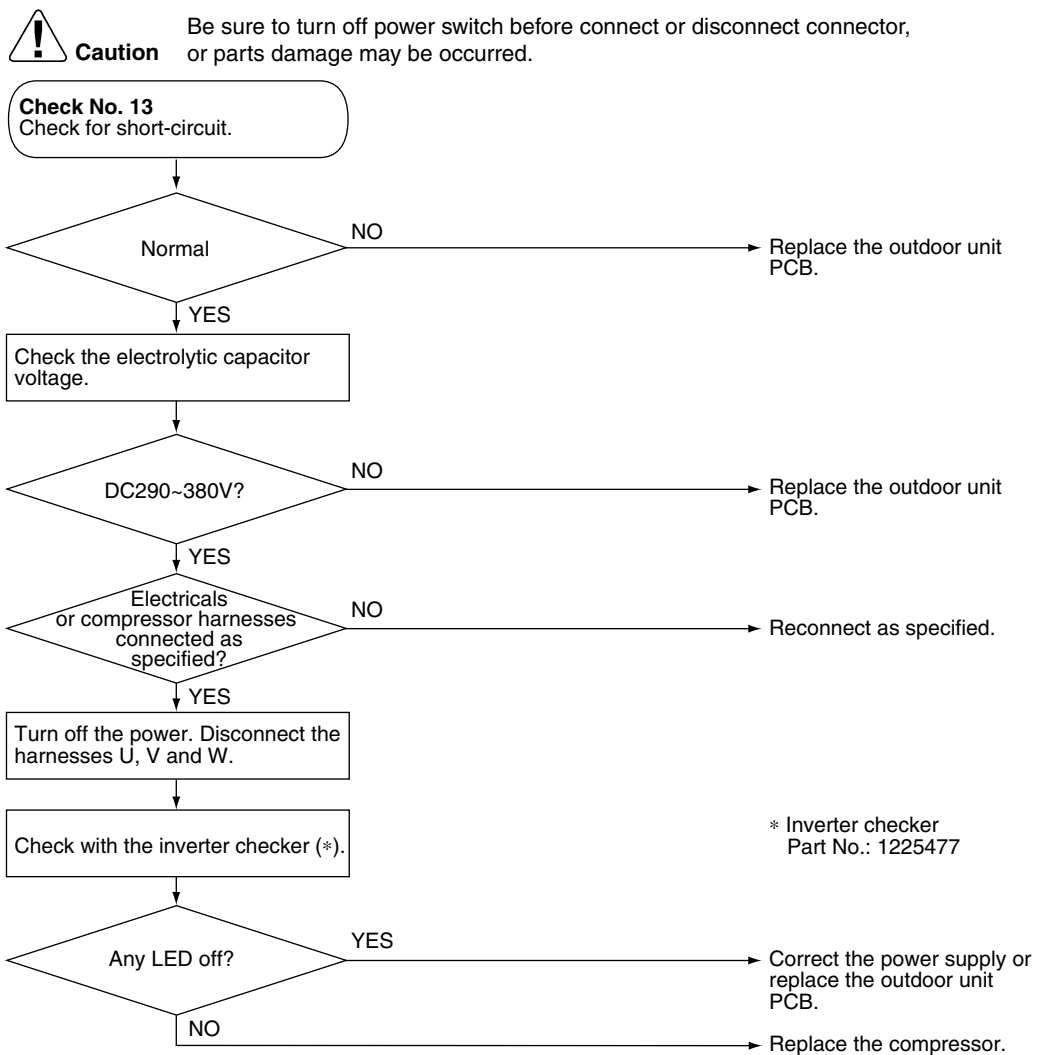

(R3041)

4.15 DC Voltage / Current Sensor Abnormality

Remote
Controller
Display

H8

Method of
Malfunction
Detection

Detecting abnormality of the DC sensor by the running frequency of compressor and by the input current multiplied DC voltage and current.

Malfunction
Decision
Conditions

The compressor running frequency is below 52 Hz.
(The input current is also below 0.5 A.)

- If this error repeats 4 times, the system will be shut down.
- The error counter will reset itself if this or any other error does not occur during the following 60-minute compressor running time (total time).

Supposed
Causes

- Outdoor unit PCB defective

Troubleshooting



Caution

Be sure to turn off power switch before connect or disconnect connector, or parts damage may be occurred.

Replace the outdoor unit PCB.

4.16 Thermistor or Related Abnormality (Outdoor Unit)

Remote
Controller
Display

P4, J3, J6, H9

Method of
Malfunction
Detection

This type of error is detected by checking the thermistor input voltage to the microcomputer.
[A thermistor error is detected by checking the temperature.]

Malfunction
Decision
Conditions

The thermistor input is above 4.96 V or below 0.04 V with the power on.
Error *J3* is judged if the discharge pipe thermistor temperature is smaller than the condenser thermistor temperature.

Supposed
Causes

- Connector in poor contact
- Thermistor defective
- Outdoor unit PCB defective
- Indoor unit PCB defective
- Condenser thermistor defective in the case of *J3* error (outdoor unit heat exchanger thermistor in the cooling mode, or indoor unit heat exchanger thermistor in the heating mode)

Troubleshooting



Check No.6
Refer to P.126

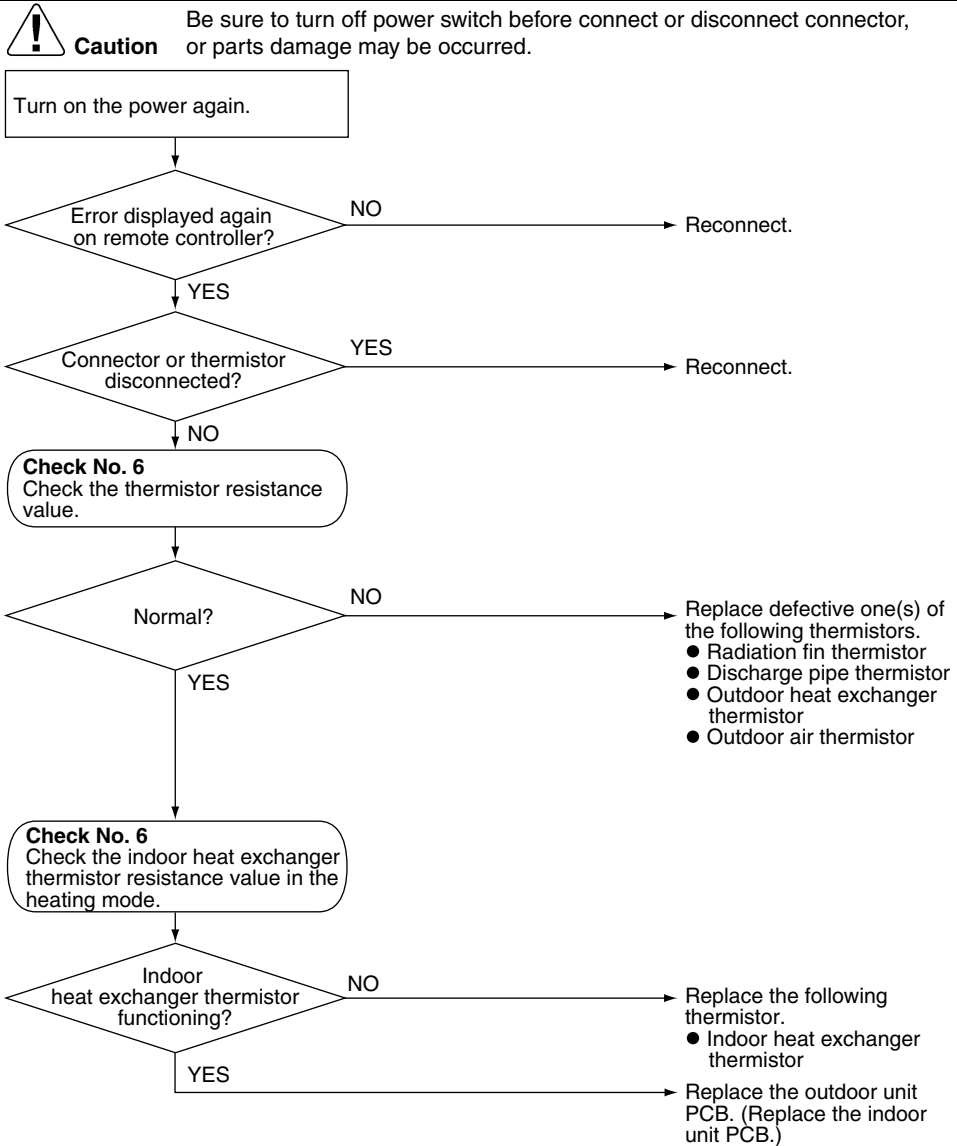

(R4097)

- P4 : Radiation fin thermistor
- J3 : Discharge pipe thermistor
- J5 : Outdoor heat exchanger thermistor
- H9 : Outdoor air temperature thermistor

4.17 Electrical Box Temperature Rise

Remote
Controller
Display

L3

Method of
Malfunction
Detection

An electrical box temperature rise is detected by checking the radiation fin thermistor with the compressor off.

Malfunction
Decision
Conditions

With the compressor off, the radiation fin temperature is above 80°C(90°C★). Reset is made when the temperature drops below 70°C(80°C★).

★: value for (A)RK(X)H, R(Y)N models

Supposed
Causes

- Fin temperature rise due to defective outdoor unit fan
- Fin temperature rise due to short-circuit
- Fin thermistor defective
- Connector in poor contact
- Outdoor unit PCB defective

Troubleshooting

 **Check No.6**
Refer to P.126

 **Check No.7**
Refer to P.127

 **Check No.9**
Refer to P.128

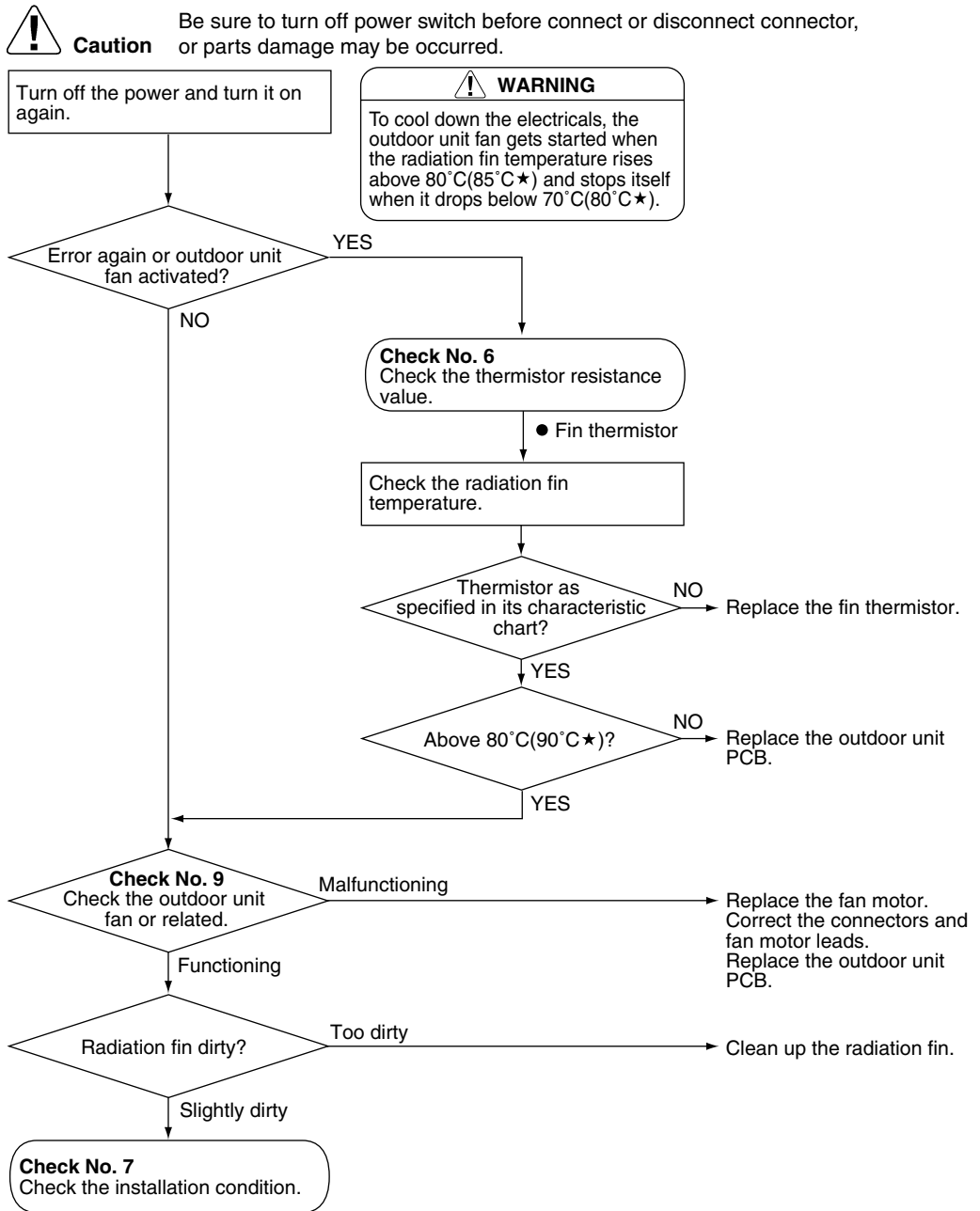

★: value for (A)RK(X)H, R(Y)N models

(R4016)

4.18 Radiation Fin Temperature Rise

Remote
Controller
Display

L4

Method of
Malfunction
Detection

A radiation fin temperature rise is detected by checking the radiation fin thermistor with the compressor on.

Malfunction
Decision
Conditions

If the radiation fin temperature with the compressor on is above 90°C (100°C for (A)RK(X)H, R(Y)N models).

- If a radiation fin temperature rise takes place 4 times successively, the system will be shut down.
- The error counter will reset itself if this or any other error does not occur during the following 60-minute compressor running time (total time).

Supposed
Causes

- Fin temperature rise due to defective outdoor unit fan
- Fin temperature rise due to short-circuit
- Fin thermistor defective
- Connector in poor contact
- Outdoor unit PCB defective

Troubleshooting

 **Check No.6**
Refer to P.126

 **Check No.7**
Refer to P.127

 **Check No.9**
Refer to P.128

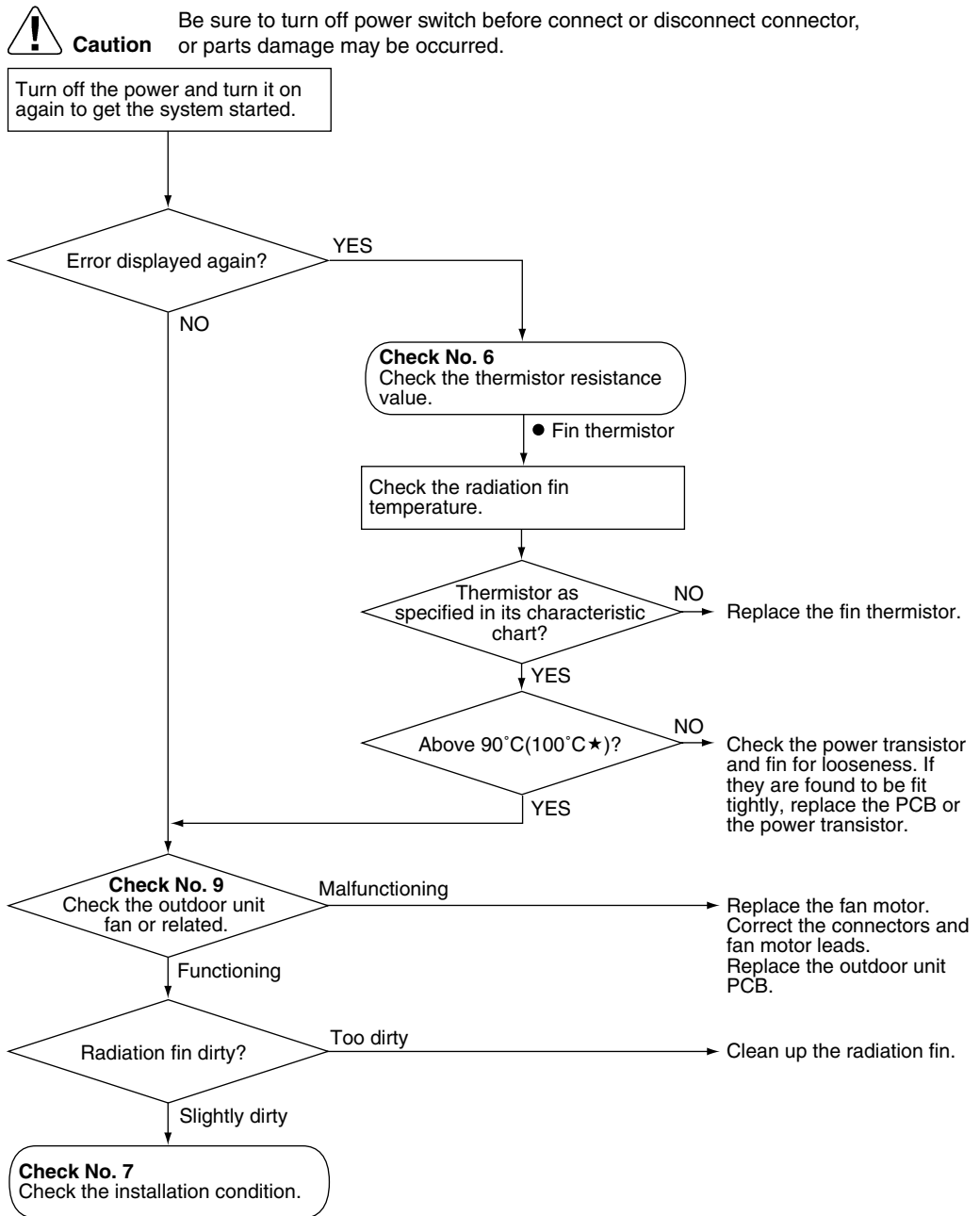

★: value for (A)RK(X)H, R(Y)N models

(R4017)

4.19 Output Over Current Detection

Remote
Controller
Display

L5

Method of
Malfunction
Detection

An output over-current is detected by checking the current that flows in the inverter DC section.

Malfunction
Decision
Conditions

- A position signal error occurs while the compressor is running.
- A speed error occurs while the compressor is running.
- An output over-current input is fed from the output over-current detection circuit to the microcomputer.
- The system will be shut down if the error occurs 255 times.
- Clearing condition: Continuous run for about 10 minutes (normal)

Supposed
Causes

- Over-current due to defective power transistor
- Over-current due to wrong internal wiring
- Over-current due to abnormal supply voltage
- Over-current due to defective PCB
- Error detection due to defective PCB
- Over-current due to closed stop valve
- Over-current due to compressor failure
- Over-current due to poor installation condition

Troubleshooting



Check No.7
 Refer to P.127

Check No.8
 Refer to P.127

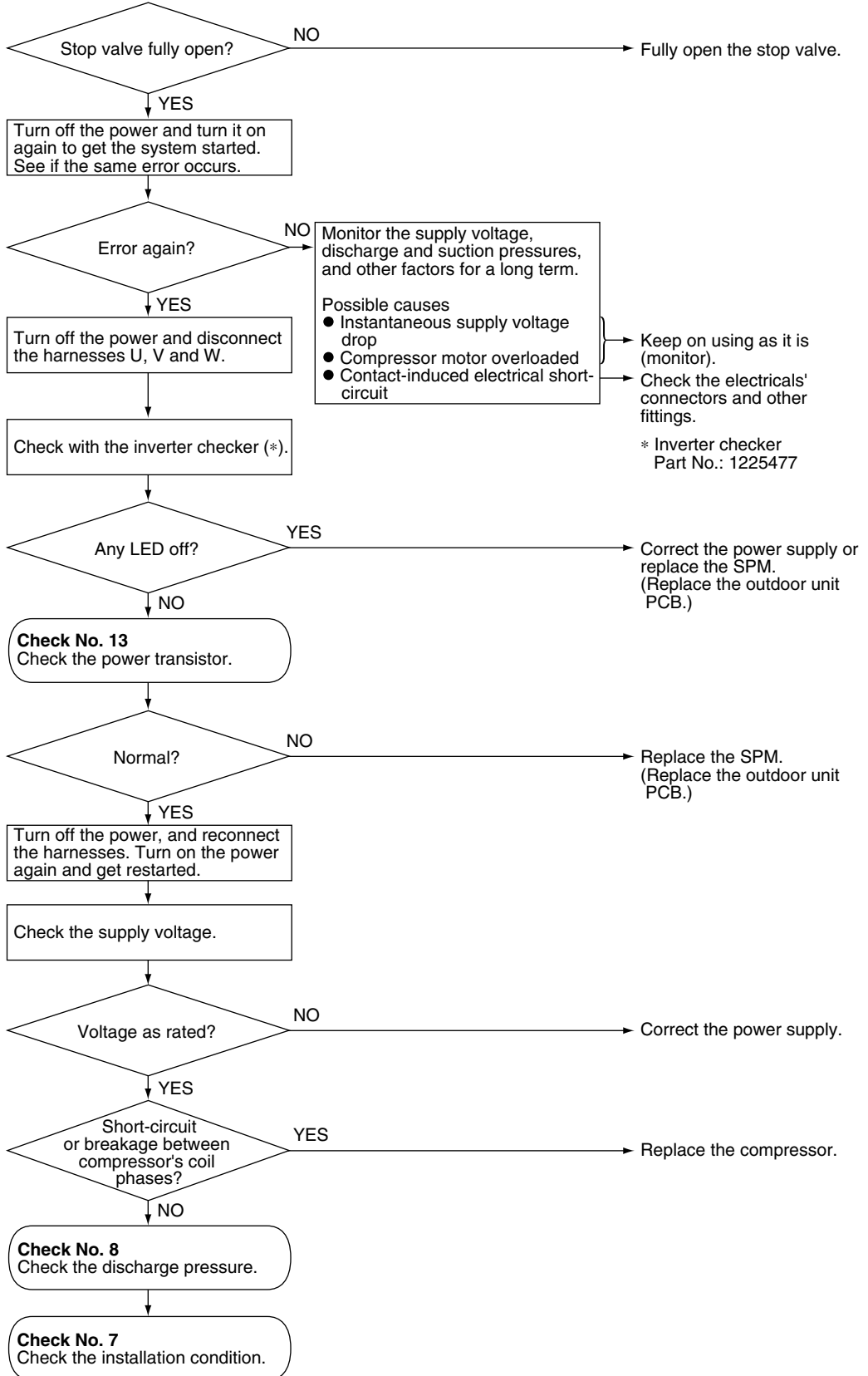

Check No.13
 Refer to P.130

 **Caution** Be sure to turn off power switch before connect or disconnect connector, or parts damage may be occurred.

* An output over-current may result from wrong internal wiring. If the wires have been disconnected and reconnected for part replacement, for example, and the system is interrupted by an output over-current, take the following procedure.



* Inverter checker
 Part No.: 1225477

 **Note:** If the model doesn't have SPM, replace the outdoor unit PCB.

(R2852)

4.20 Insufficient Gas

Remote
Controller
Display



Method of
Malfunction
Detection

Gas shortage detection I : A gas shortage is detected by checking the compressor running frequency.

Gas shortage detection II : A gas shortage is detected by checking the difference between indoor unit heat exchanger temperature and room temperature as well as the difference between outdoor unit heat exchanger temperature and room temperature.

Gas shortage detection III : A gas shortage is detected by checking the difference between inhale and exhale temperature.

Malfunction
Decision
Conditions

Gas shortage detection I :

Input current < Δ (A/Hz) x Compressor running frequency x Voltage + B

However, when the status of running frequency > C (Hz) is kept on for a certain time.

Note : The values are different from model to model.

	Δ	B	C
(A)RK(X)S models	640 / 256	0	55
(A)RK(X)H, R(Y)N models	640 / 256	50	55

Gas shortage detection II :

If a gas shortage error takes place 4 times successively, the system will be shut down. The error counter will reset itself if this or any other error does not occur during the following 60-minute compressor running time (total time).

Gas shortage detection III :

When the difference of the temperature is smaller than Δ , it is regarded as insufficient gas.

		Δ
Cooling	room temperature – indoor heat exchanger temperature	4.0°C
	outdoor heat exchanger temperature – outdoor temperature	4.0°C
Heating	indoor heat exchanger temperature – room temperature	4.0°C
	outdoor temperature – outdoor heat exchanger temperature	3.0°C

Supposed
Causes

- Refrigerant shortage (refrigerant leakage)
- Poor compression performance of compressor
- Discharge pipe thermistor disconnected, or indoor unit or outdoor unit heat exchanger thermistor disconnected, room or outdoor air temperature thermistor disconnected
- Stop valve closed
- Electronic expansion valve defective

Troubleshooting



Check No.4
Refer to P.124



Check No.6
Refer to P.126



Caution Be sure to turn off power switch before connect or disconnect connector, or parts damage may be occurred.

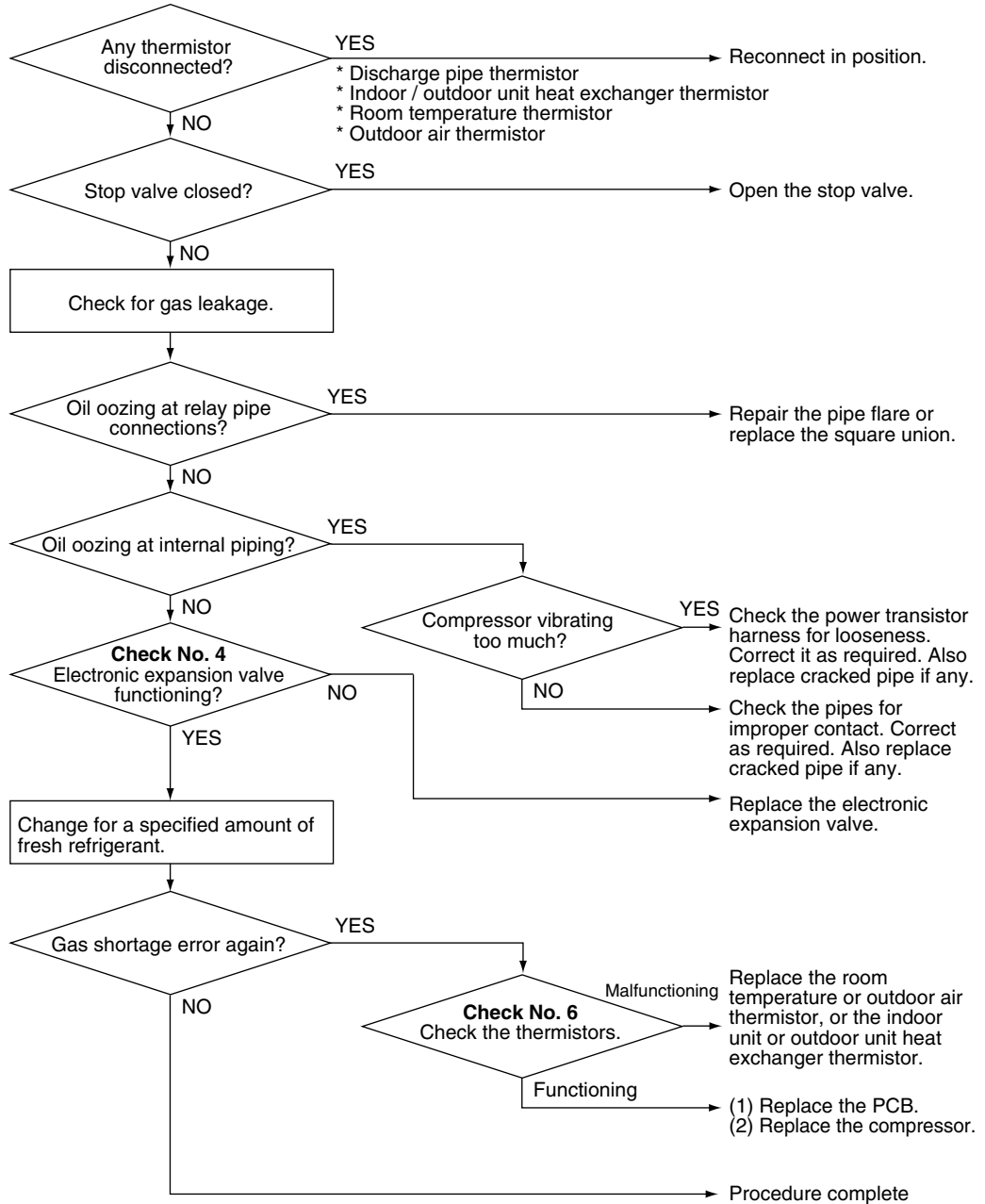

(R3318)

4.21 Over-voltage Detection

Remote
Controller
Display

U2

Method of
Malfunction
Detection

An abnormal voltage rise is detected by checking the specified over-voltage detection circuit.

Malfunction
Decision
Conditions

- An over-voltage signal is fed from the over-voltage detection circuit to the microcomputer (The voltage is over 400V).
- The system will be shut down if the error occurs 255 times.
- Clearing condition: Continuous run for about 10 minutes (normal)

Supposed
Causes

- Supply voltage not as specified
- Over-voltage detection circuit defective
- PAM control part(s) defective

Troubleshooting

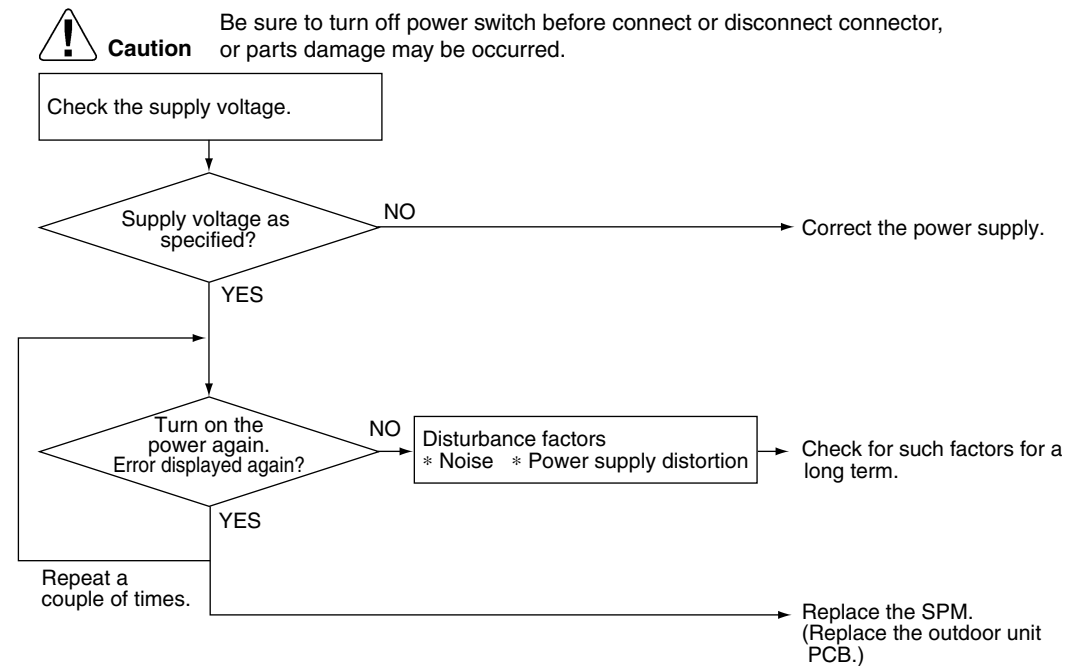

(R2957)



Note: If the model doesn't have SPM, replace the outdoor unit PCB.

5. Check

5.1 How to Check

5.1.1 Electronic Expansion Valve Check

Check No.4

Conduct the followings to check the electronic expansion valve (EV).

1. Check to see if the EV connector is correctly inserted in the PCB. Compare the EV unit and the connector number.
2. Turn the power off and back on again, and check to see if all the EVs generate latching sound.
3. If any of the EVs does not generate latching noise in the above step 2, disconnect that connector and check the conductivity using a tester.
Check the conductivity between pins 1, 3 and 6, and between pins 2, 4 and 5. If there is no conductivity between the pins, the EV coil is faulty.

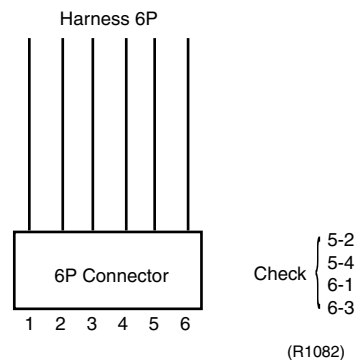

4. If no EV generates latching sound in the above step 2, the outdoor unit PCB is faulty.
5. If the conductivity is confirmed in the above step 2, mount a good coil (which generated latching sound) in the EV unit that did not generate latching sound, and check to see if that EV generates latching sound.
*If latching sound is generated, the outdoor unit PCB is faulty.
*If latching sound is not generated, the EV unit is faulty.



Note: Please note that the latching sound varies depending on the valve type.

5.1.2 Four Way Valve Performance Check

Check No.5

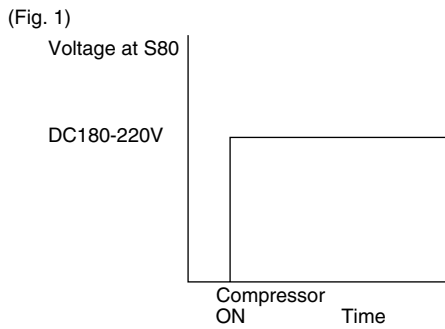
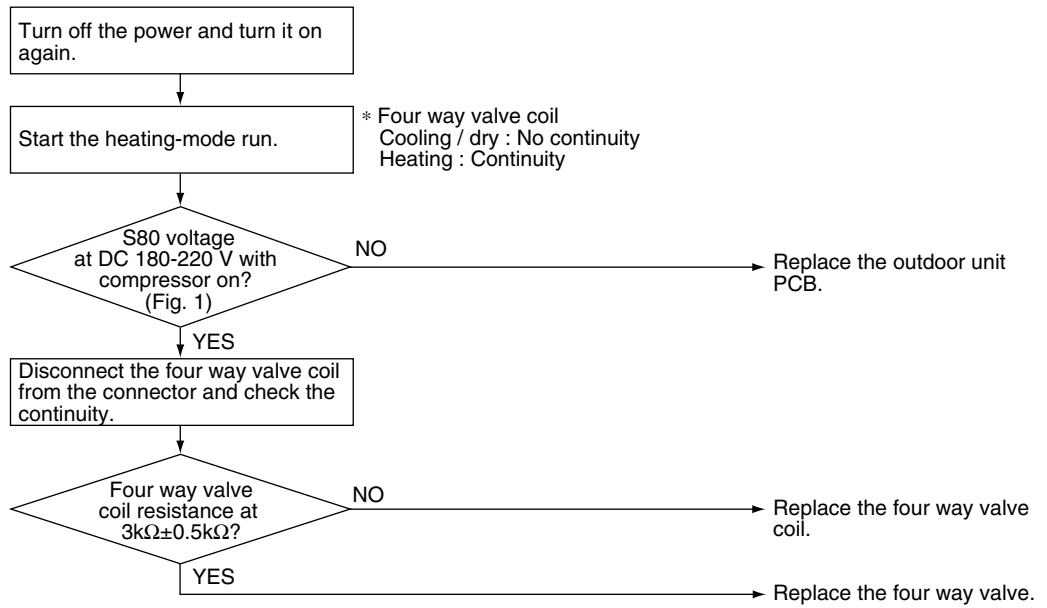

(R3047)

5.1.3 Thermistor Resistance Check

Check No.6

Remove the connectors of the thermistors on the PCB, and measure the resistance of each thermistor using tester.
 The relationship between normal temperature and resistance is shown in the graph and the table below.

Temperature (°C)	Thermistor R25°C=20kΩ B=3950
-20	211.0 (kΩ)
-15	150
-10	116.5
-5	88
0	67.2
5	51.9
10	40
15	31.8
20	25
25	20
30	16
35	13
40	10.6
45	8.7
50	7.2

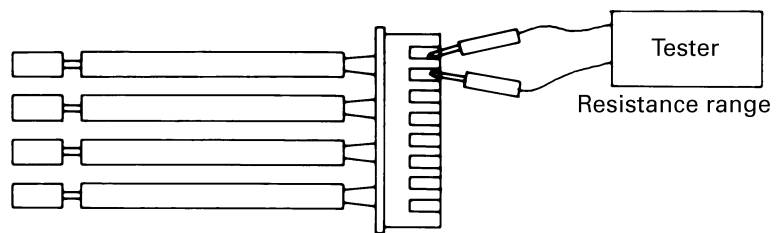

(R25 = 20k Ω 、 B = 3950)

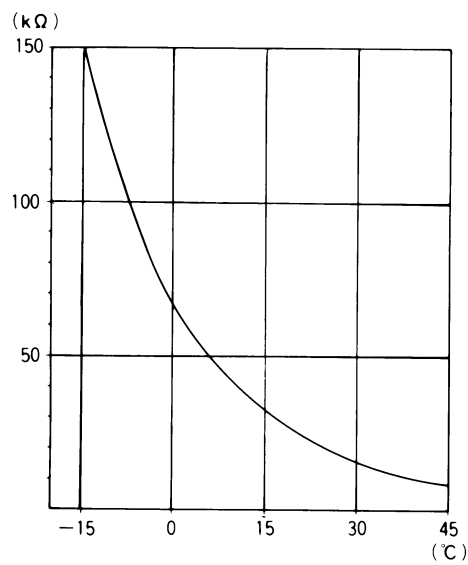

(R1437)

5.1.4 Installation Condition Check

Check No.7

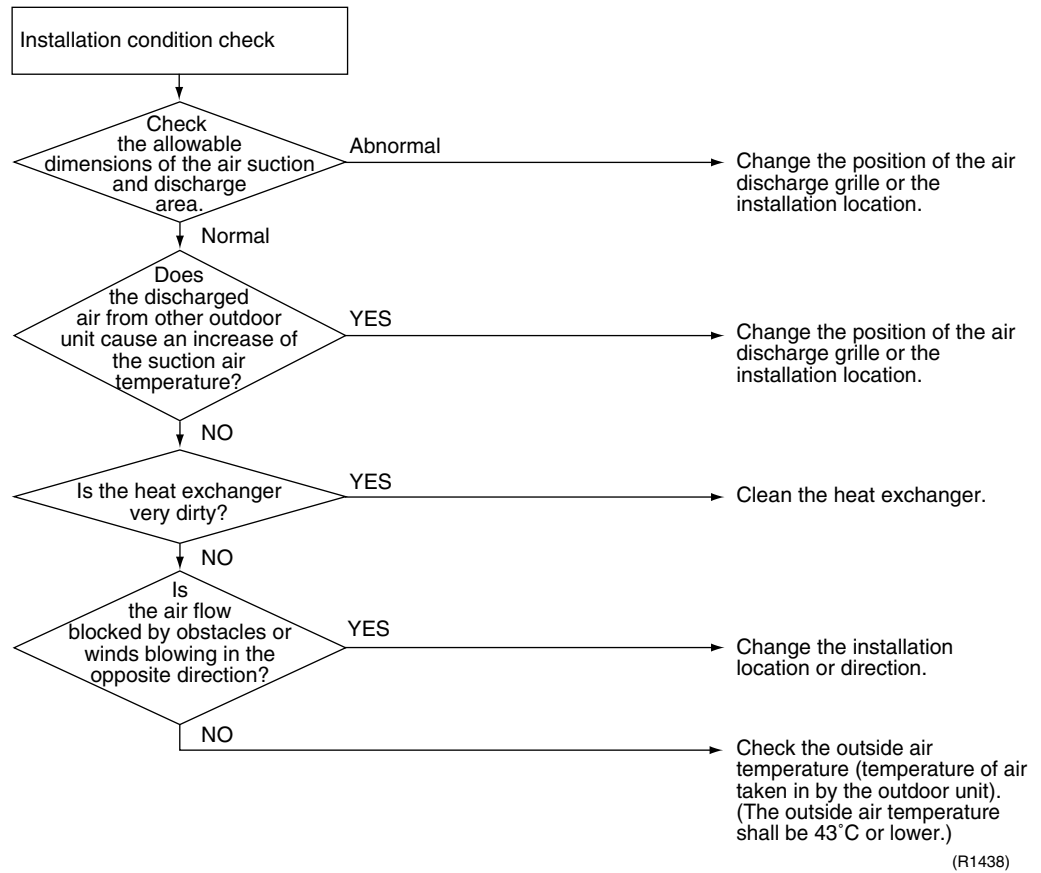

5.1.5 Discharge Pressure Check

Check No.8

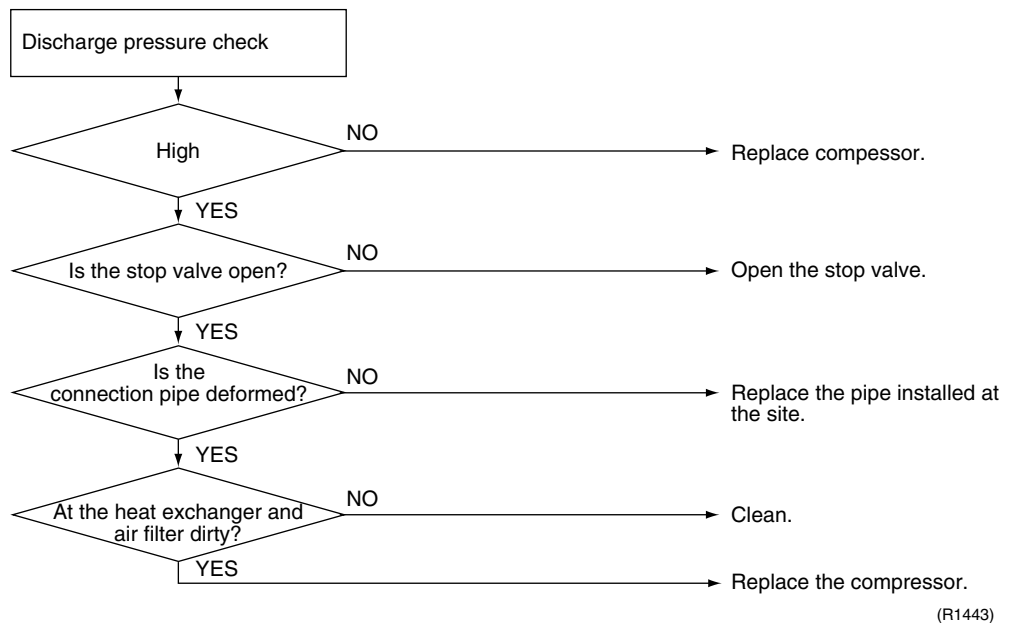

5.1.6 Outdoor Unit Fan System Check

Check No.9

DC motor — (A)RK(X)S models

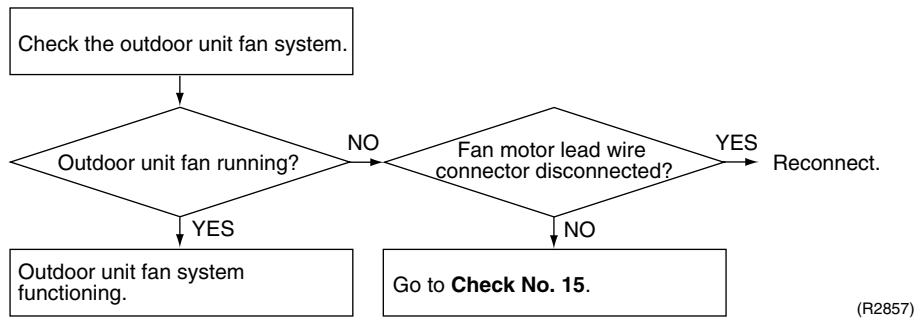

(R2857)

AC motor — (A)RK(X)H, R(Y)N models

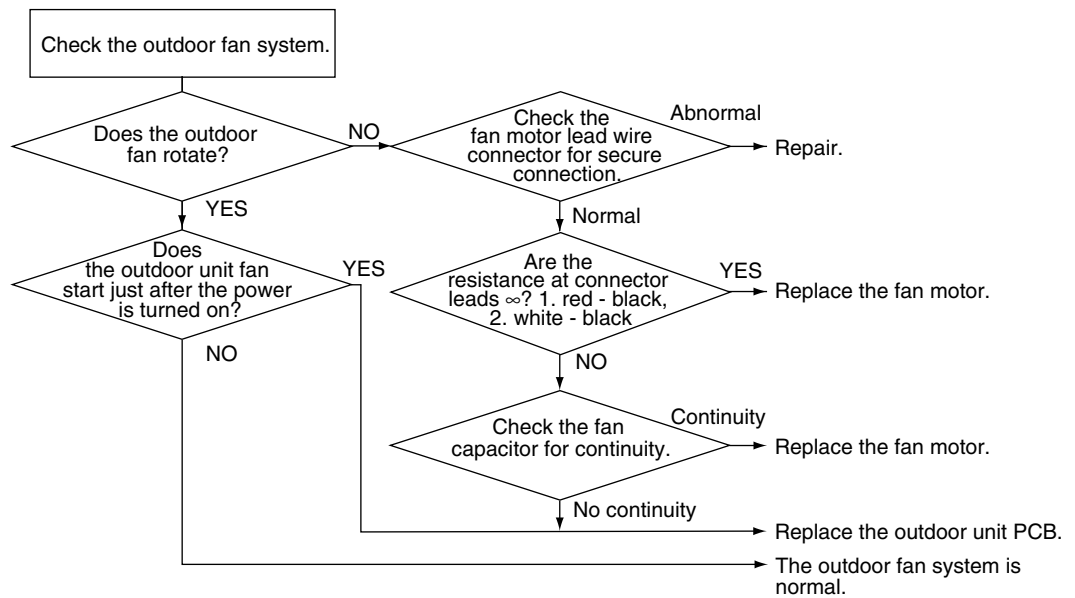

(R2670)

5.1.7 Power Supply Waveforms Check

Check No.10

Measure the power supply waveform between pins 1 and 3 on the terminal board, and check the waveform disturbance.

- Check to see if the power supply waveform is a sine wave (Fig.1).
- Check to see if there is waveform disturbance near the zero cross (sections circled in Fig.2)

[Fig.1]

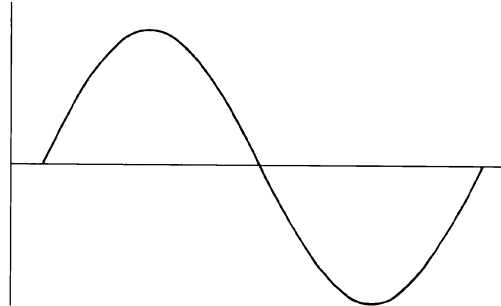

(R1736)

[Fig.2]

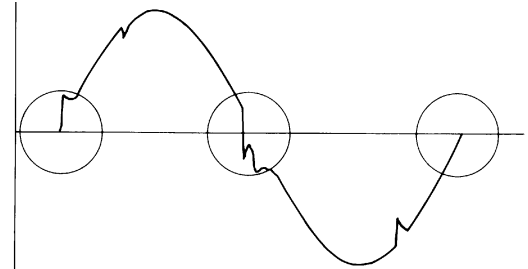

(R1444)

5.1.8 Inverter Units Refrigerant System Check

Check No.11

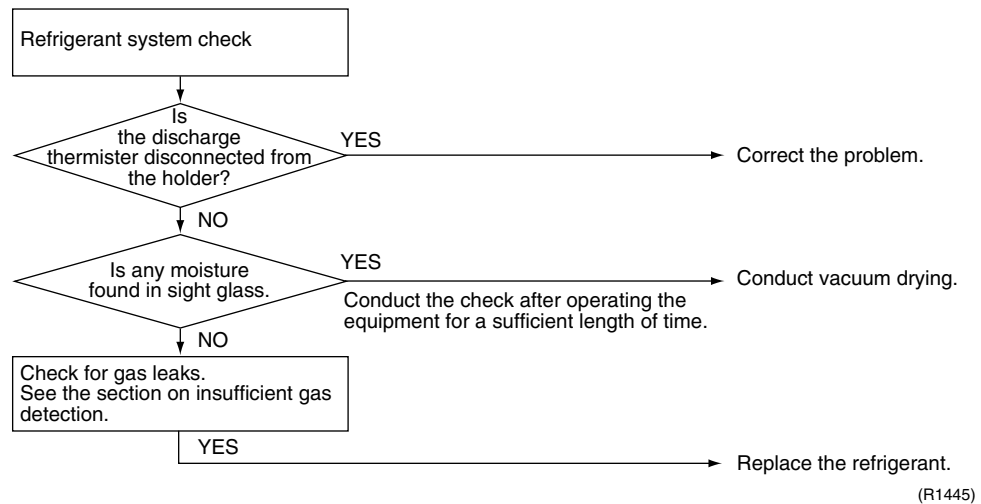

5.1.9 Power Transistor Check

Check No.13



Note: Check to make sure that the voltage between the terminal of Power transistor (+) and (-) is approx. 0 volt before checking power transistor.

< Measuring method >

Disconnect the compressor harness connector from the outdoor unit PCB. To disengage the connector, press the protrusion on the connector.

Then, follow the procedure below to measure resistance between power transistor (+) and (-) and the U, V and W terminals of the compressor connector with a multi-tester. Evaluate the measurement results for a pass/fail judgment.

<Power transistor check>

Negative (-) terminal of tester (positive terminal (+) for digital tester)	Power transistor (+)	UVW	Power transistor (-)	UVW
Positive (+) terminal of tester (negative terminal (-) for digital tester)	UVW	Power transistor (+)	UVW	Power transistor (-)
Normal resistance	Several kΩ to several MΩ (*)			
Unacceptable resistance	Short (0 Ω) or open			

5.1.10 Turning Speed Pulse Input on the Outdoor Unit PCB Check

Check No.15

<Propeller fan motor>

Make sure the voltage of 270±30V is being applied.

- (1) Stop the operation first and then the power off, and disconnect the connector S70.
- (2) Make sure there is about DC 270 V between pins 4 and 7.
- (3) With the system and the power still off, reconnect the connector S70.
- (4) Make a turn of the fan motor with a hand, and make sure the pulse (0-15 V) appears twice at pins 1 and 4.

If the fuse is blown out, the outdoor-unit fan may also be in trouble. Check the fan too.

If the voltage in Step (2) is not applied, it means the PCB is defective. Replace the PCB.

If the pulse in Step (4) is not available, it means the Hall IC is defective. Replace the DC fan motor. If there are both the voltage (2) and the pulse (4), replace the PCB.

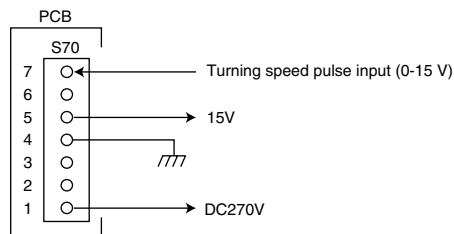

(R2859)

* Propeller fan motor : S70

5.1.11 Hall IC Check

Check No.16

1. Check the connector connection.
2. With the power ON, operation OFF, and the connector connected, check the following.
 - *Output voltage of about 5 V between pins 1 and 3.
 - *Generation of 3 pulses between pins 2 and 3 when the fan motor is operating.

Failure of (1) → faulty PCB → Replace the PCB.

Failure of (2) → faulty Hall IC → Replace the fan motor.

Both (1) and (2) result → Replace the PCB.

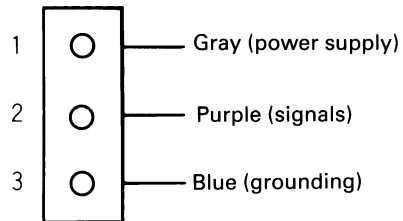

(R1968)

Part 7

Removal Procedure

1. Indoor Unit.....	134
1.1 Removal of Air Filter.....	134
1.2 Removal of Front Grille	137
1.3 Removal of Horizontal Blade and Vertical Blade.....	140
1.4 Removal of Electrical Box, PCB and Swing Motor	142
1.5 Removal of Heat Exchanger	148
1.6 Install of Drain Plug	151
1.7 Removal of Fan Rotor and Fan Motor.....	152
2. Outdoor Unit / RK(X)S-C, ARK(X)S-C	156
2.1 Removal of Panels and Fan Motor.....	156
2.2 Removal of Electrical Box	163
2.3 Removal of Reactor and Partition Plate	165
2.4 Removal of Sound Blanket.....	167
2.5 Removal of Four Way Valve.....	169
2.6 Removal of Compressor.....	171
2.7 Removal of PCB.....	173
3. Outdoor Unit / RK(X)H-C, ARK(X)H-C, R(Y)N-C	176
3.1 Removal of External Panels	176
3.2 Removal of Bell mouth	179
3.3 Removal of PCB and Electrical Box	180
3.4 Removal of Propeller Fan and Fan Motor	187
3.5 Removal of Partition Plate and Reactor	190
3.6 Removal of Sound Insulation Pad	193
3.7 Removal of Electronic Expansion Valve and Four Way Valve	196
3.8 Removal of Compressor.....	200

1. Indoor Unit

1.1 Removal of Air Filter

Procedure

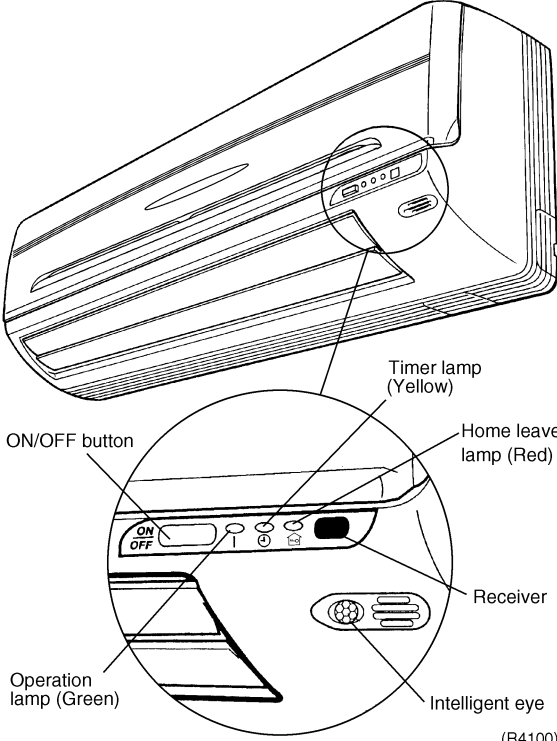
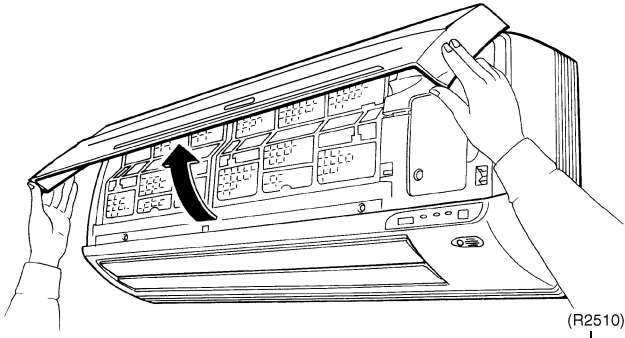
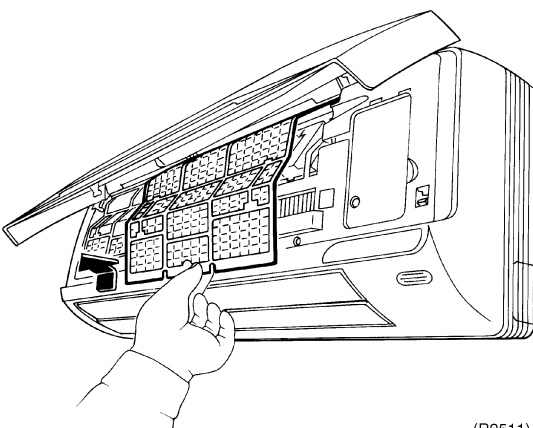

Warning Be sure to wait 10 minutes or more after turning off all power supplies before disassembling work..

Step	Procedure	Points
1. External features		<ul style="list-style-type: none"> ■ If ON/OFF button is kept pushing for 5 seconds, a forced cooling operation will be carried out for approx. 15 minutes.
2. Removing air filters	<p>1 Pull protrusions on left and right sides of panel with fingers and open front grille all the way.</p>  <p>2 Lift center section of air filter and disengage hooks. Remove air filter by pulling forward.</p> 	<ul style="list-style-type: none"> ■ Left and right filters are interchangeable. ■ To re-install, insert air filter along the guide.

Step	Procedure	Points
<p>3. Opening and shutting front panel</p>		<p>Support the front panel by one hand, while remove the rotation axis at the upper center by the other hand.</p> <ul style="list-style-type: none"> ■ And pull out the front panel forward to remove.
<p>1</p>	<p>Hook a finger onto the projection part provided on the both sides of the unit's panel and open up the panel to the position higher than it will stop.</p>	
<p>2</p>	<p>Remove front panel from the unit.</p>	

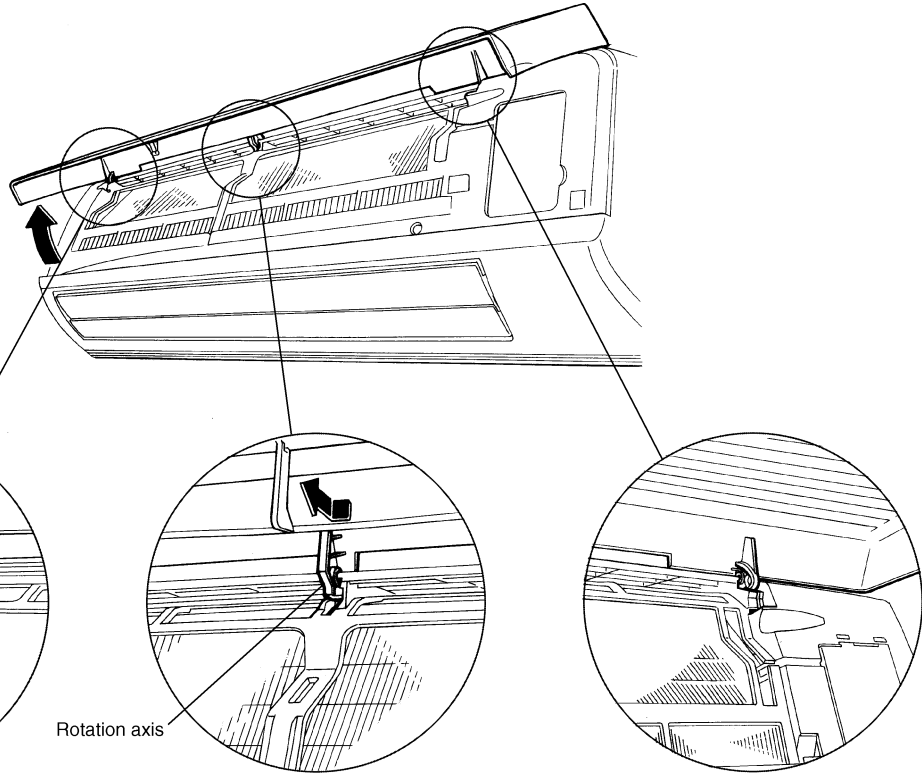

Rotation axis

Slide the center rotary axis the left and remove it out.

(R2512)

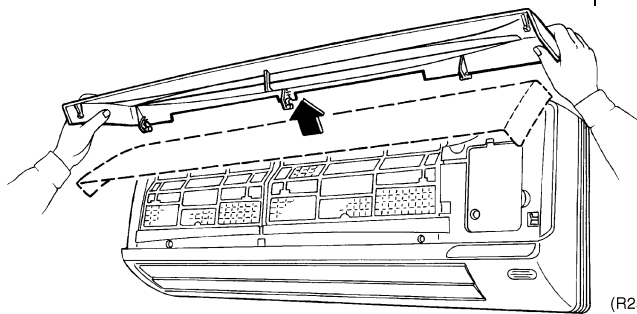

(R2513)

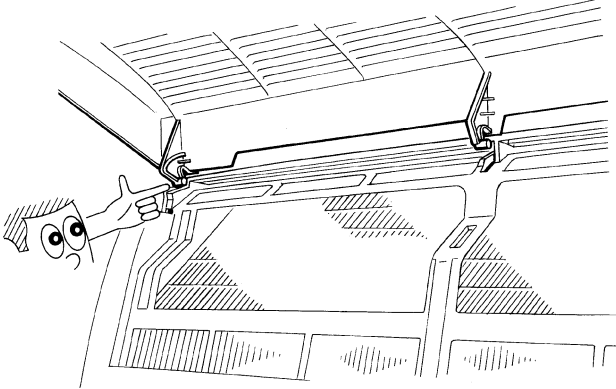
Step	Procedure	Points
3	<p data-bbox="201 217 467 409">When restoring the air filter, make sure that the projection parts on the panel are in the guide groove, and then shut the panel.</p>  <p data-bbox="1118 629 1177 651">(R2514)</p>	

1.2 Removal of Front Grille

Procedure

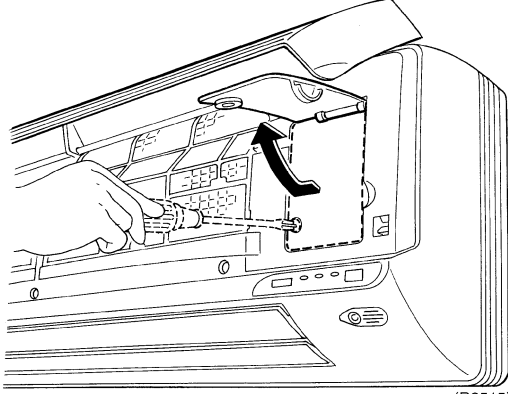
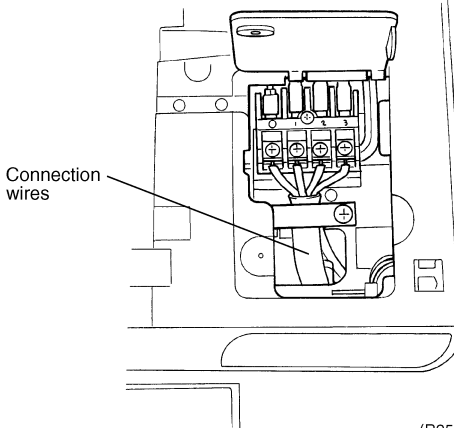

Warning Be sure to wait 10 minutes or more after turning off all power supplies before disassembling work.

Step	Procedure	Points
1. Opening and closing of service cover	 <p style="text-align: right;">(R2515)</p>  <p style="text-align: right;">(R2516)</p>	<ul style="list-style-type: none"> ■ A switch for field setting is not provided in particular.

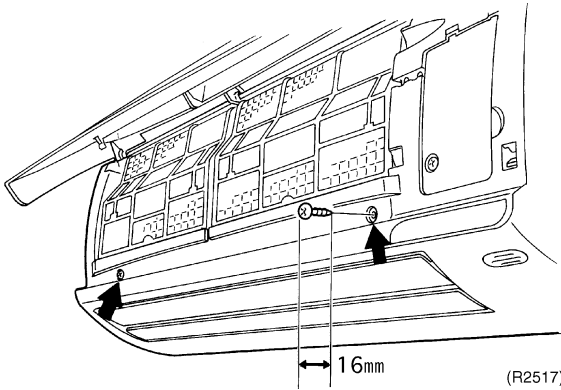
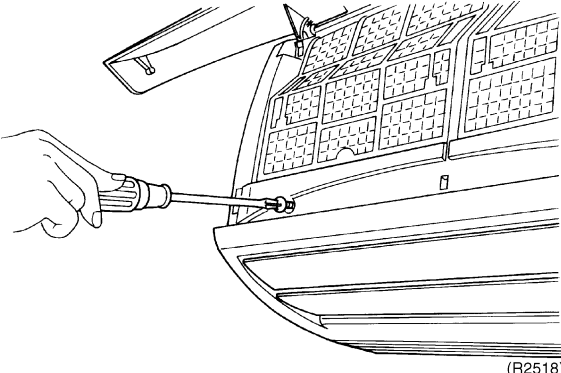
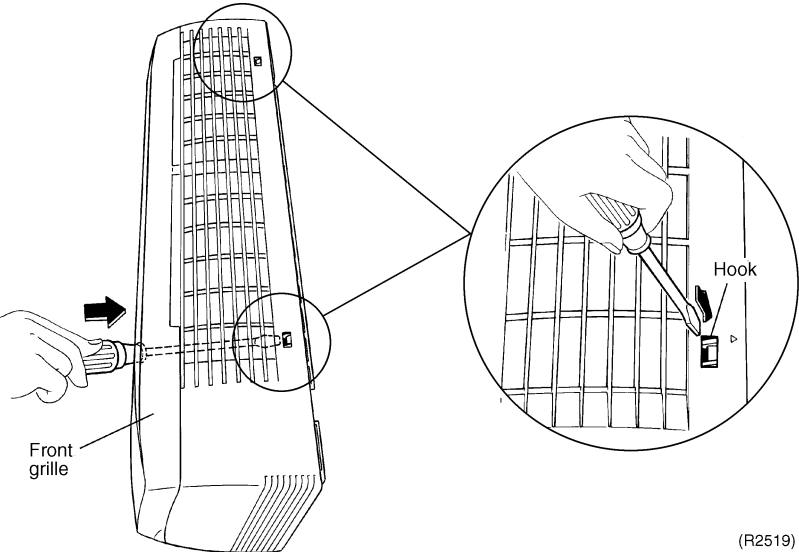
Step	Procedure	Points
<p>2. Removal of front grille assembly.</p>	<p>1 Remove the two screws, in the right and the left, which fix the main body with the front grille.</p>  <p>(R2517)</p>  <p>(R2518)</p> <p>2 Disengage the two hooks on the upper part. In case that the hooks are not pressed from above, remove the front panel and then remove the grille while pushing the hook through a clearance between the front grille and the heat exchanger.</p>  <p>(R2519)</p>	<ul style="list-style-type: none"> ■ Screw stoppers inside the flap which were equipped in the existing models are not provided. ■ At the upper part there are two hooks in the left and the right. ■ Disengage the hooks by pressing knobs with a screwdriver.

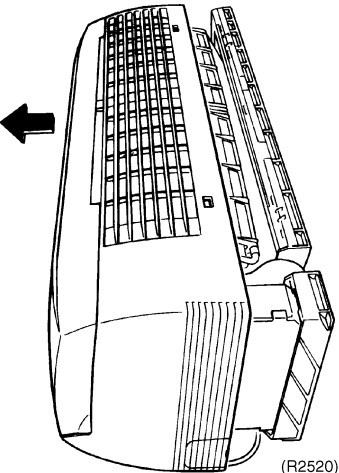
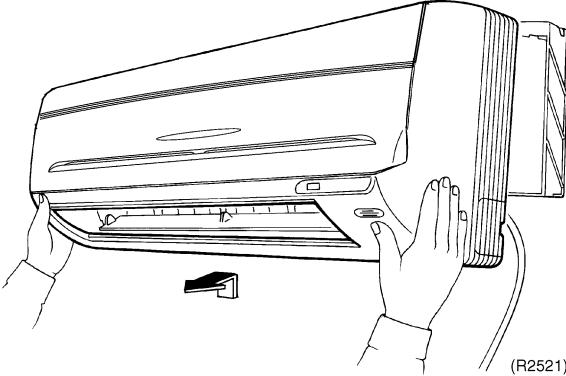
Step	Procedure	Points
3	<p data-bbox="201 215 472 376">The front grille can be removed in a manner to pull out the upper part forward and lift up the lower part.</p>  <p data-bbox="900 719 959 741">(R2520)</p>  <p data-bbox="1011 1133 1070 1155">(R2521)</p>	<ul data-bbox="1098 215 1422 309" style="list-style-type: none">■ When restoring the grille, Make sure whether each hook is set as it was.

1.3 Removal of Horizontal Blade and Vertical Blade

Procedure

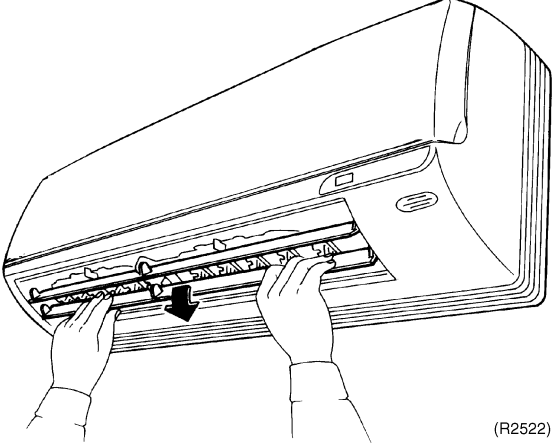
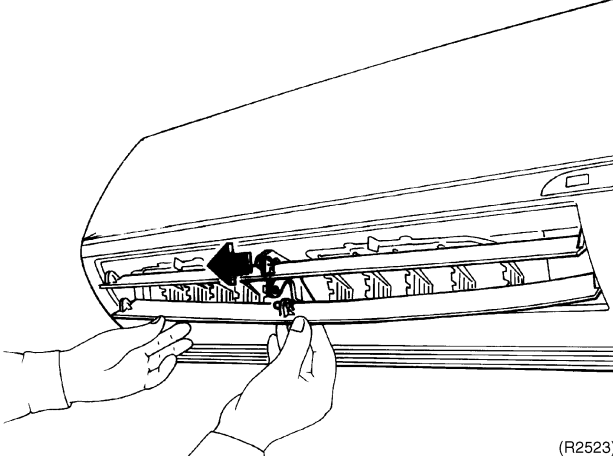
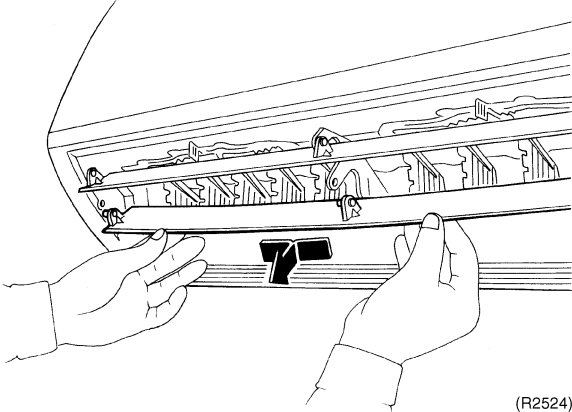

Warning Be sure to wait 10 minutes or more after turning off all power supplies before disassembling work.

Step	Procedure	Points
<p>1. Remove horizontal blade.</p> <p>1 Lift horizontal blade to open position.</p> <p>2 Disengage horizontal blade from blade retaining section.</p> <p>3 Bend blade slightly and remove it from the unit.</p>	 <p>(R2522)</p>  <p>(R2523)</p>  <p>(R2524)</p>	<ul style="list-style-type: none"> ■ Screw stoppers inside the flap which were equipped in the existing models are not provided.

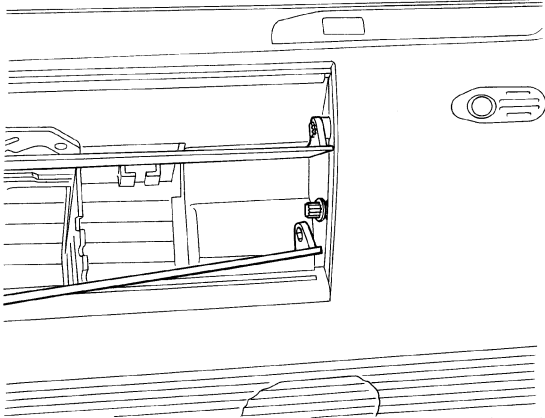
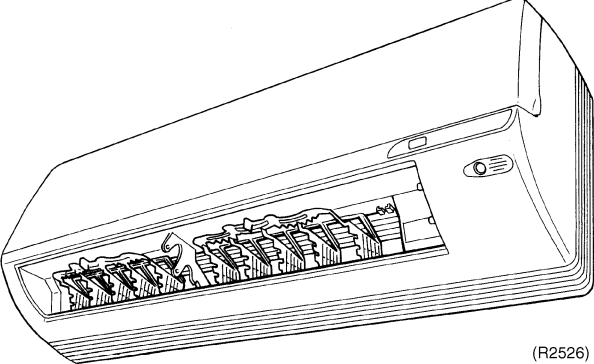
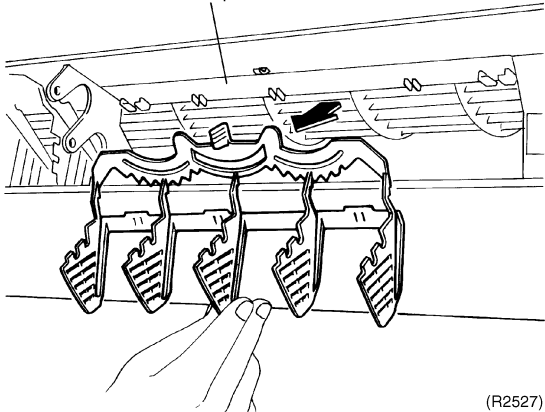
Step	Procedure	Points
	 <p style="text-align: right;">(R2525)</p>	<ul style="list-style-type: none"> ■ For restoring. 1. Since the key pattern hook is provided on the left side, insert the edge of the blade to the tip while rotating it. 2. Restore the two fixed parts of the horizontal blade onto the hook.
<p>2. Removal of vertical blade</p> <p>1</p> <p>2</p>	<p>1 Disengage the vertical blade's joint from the fixed plate.</p>  <p style="text-align: right;">(R2526)</p> <p>2 Remove the blade forward.</p>  <p style="text-align: right;">(R2527)</p>	<ul style="list-style-type: none"> ■ Five vertical blades are integrated with the joint rod. (so, only one blade can't be exchanged.)

1.4 Removal of Electrical Box, PCB and Swing Motor

Procedure



Warning Be sure to wait 10 minutes or more after turning off all power supplies before disassembling work.

Step	Procedure	Points
<p>■ Remove front grill.</p>		
<p>1. Remove electrical box.</p> <p>1 Disconnect the connection wires.</p> <p>2 Disconnect connectors (S1 and S7) of fan motor.</p> <p>3 Disconnect one connector (S6) of swing motor.</p> <p>4 Remove heat exchanger thermistor.</p>		<p>■ Pay attention to the direction of the retainer of the thermistor so that the retainer will not touch the harness (same as the existing models.)</p>

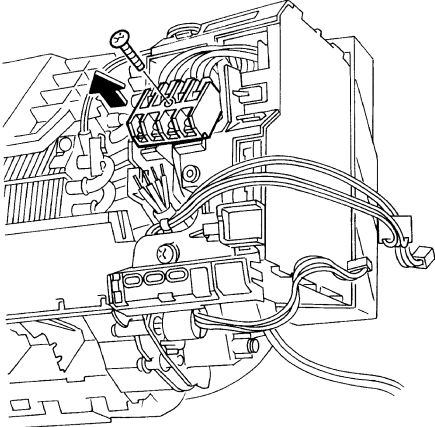
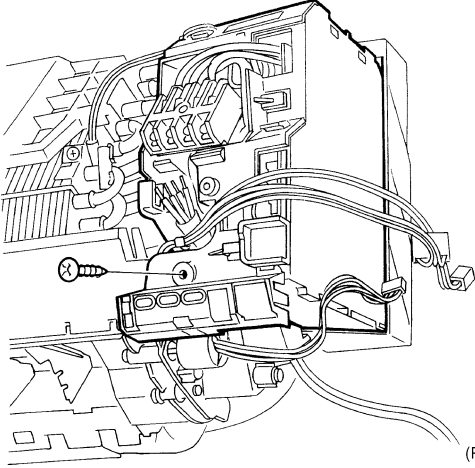
Step	Procedure	Procedure	Points
5	Remove a screw on the terminal board.	 <p>(R2531)</p>	<ul style="list-style-type: none">■ The electrical box can be removed instead of disengaging the terminal board.
6	Remove a screw on the electrical box.	 <p>(R2532)</p>	

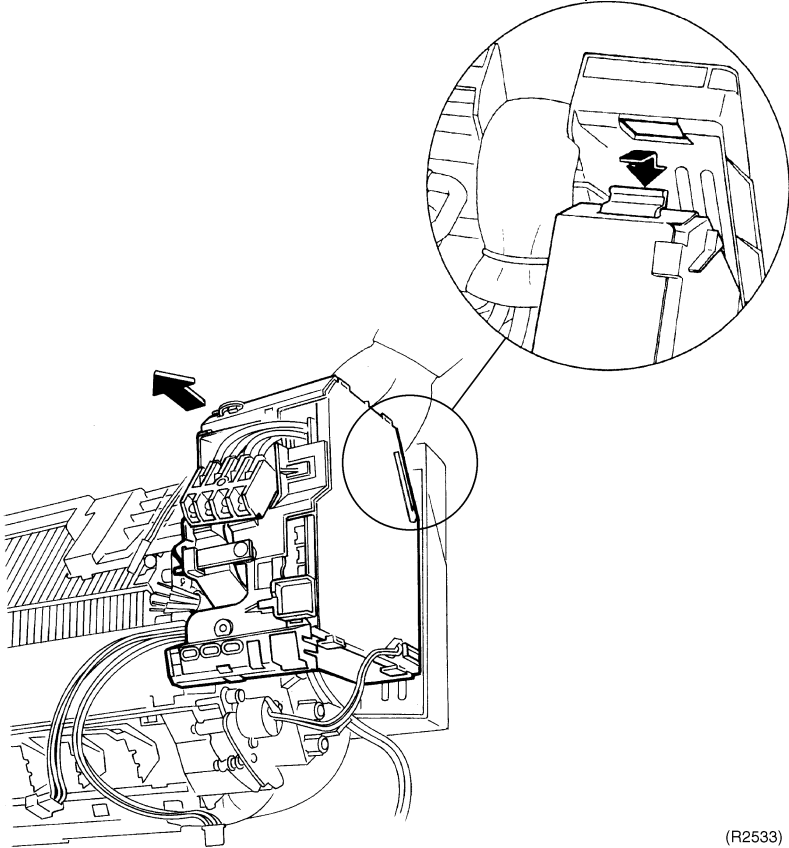
Step	Procedure	Points
7	<p data-bbox="201 215 464 275">Pull up the electrical box forward to remove.</p>  <p>The diagram shows a detailed view of an electrical box assembly. A black arrow points to the front panel of the box. A circular callout provides a magnified view of a hook mechanism on the back of the box, with another black arrow pointing to the hook's tip.</p>	<ul style="list-style-type: none"> <li data-bbox="1098 215 1426 275">■ A hook is provided on the behind. <p data-bbox="1230 1115 1289 1137">(R2533)</p>

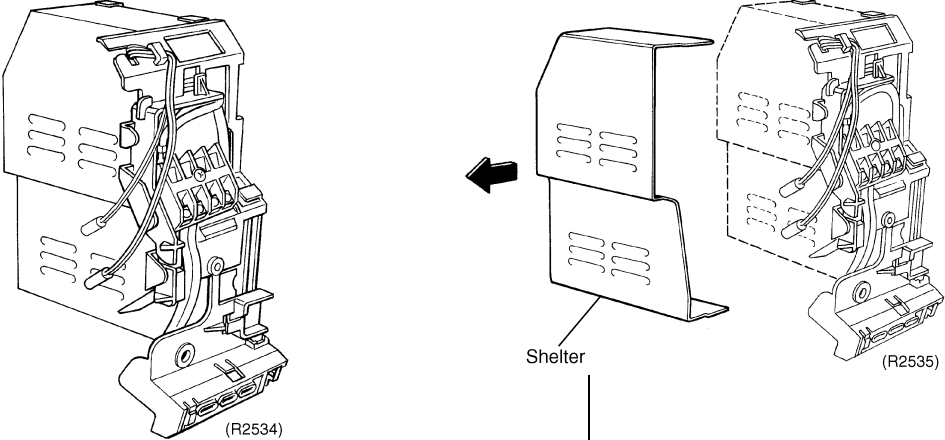
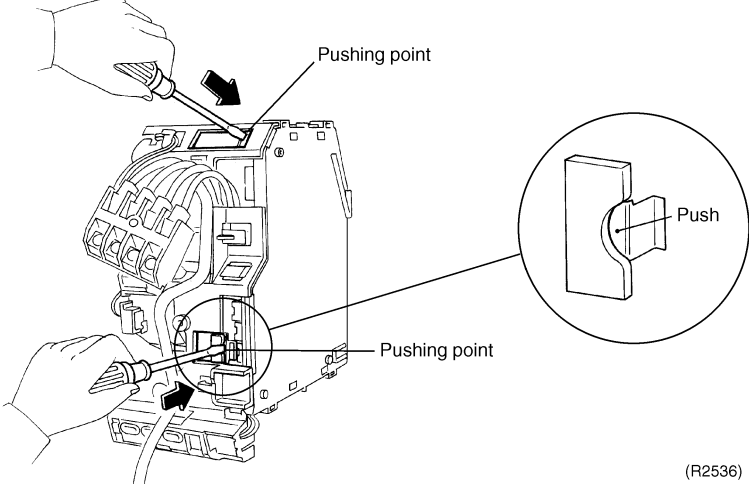
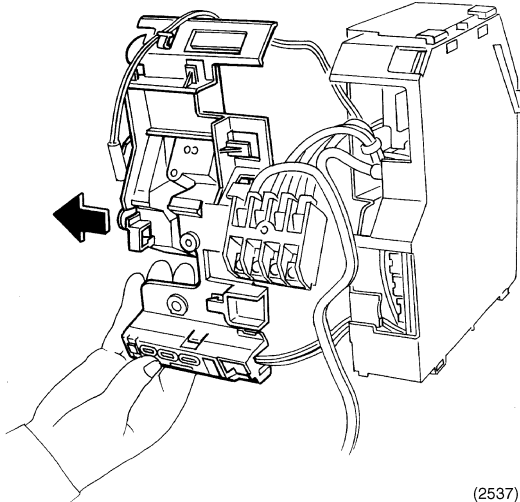
Step	Procedure	Points
2. Removal of PCB		
1	<p>Remove the shelter.</p> 	
2	<p>Disengage the front plate of the electrical box. Disengage the knobs by pushing the two hooks at the top and the bottom.</p> 	
3	<p>Sliding to the left, the front part of the electrical box can be removed.</p> 	

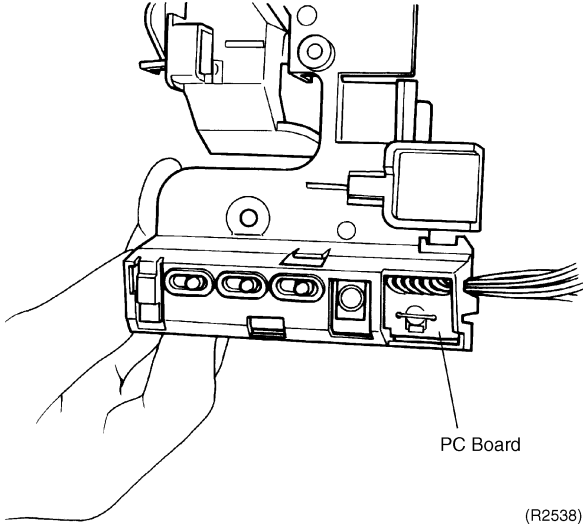
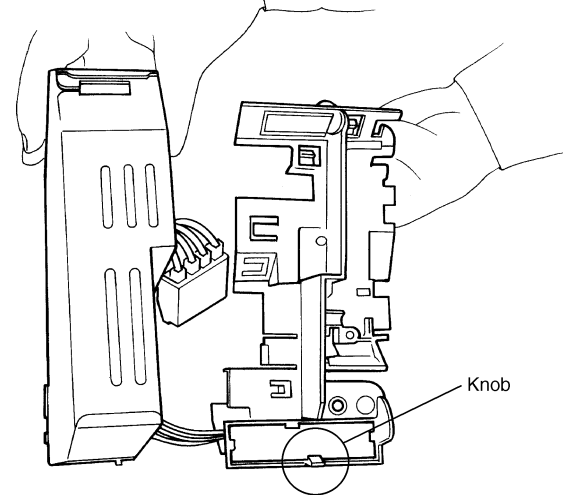
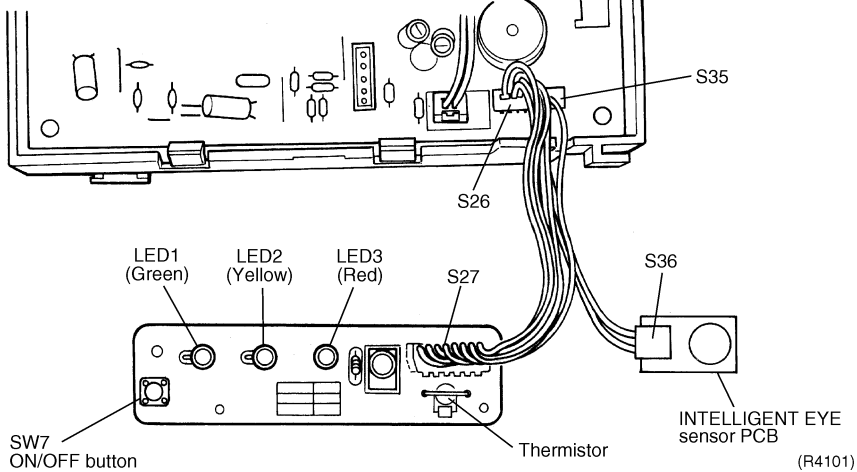
Step	Procedure	Points
4	<p>Disengage the four knobs on the back of the signal receiver PCB.</p>  <p>PC Board</p> <p>(R2538)</p>	
5	<p>Signal receiver PCB</p>  <p>Knob</p> <p>(R2539)</p>  <p>SW7 ON/OFF button</p> <p>LED1 (Green)</p> <p>LED2 (Yellow)</p> <p>LED3 (Red)</p> <p>S27</p> <p>Thermistor</p> <p>S35</p> <p>S26</p> <p>S36</p> <p>INTELLIGENT EYE sensor PCB</p> <p>(R4101)</p>	

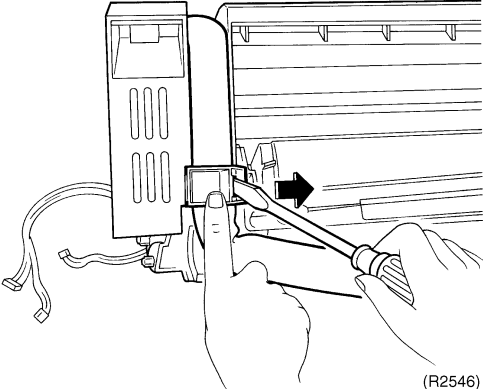
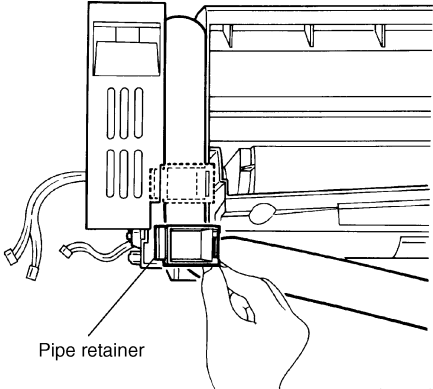
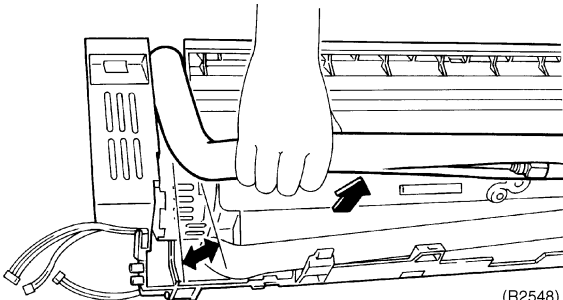
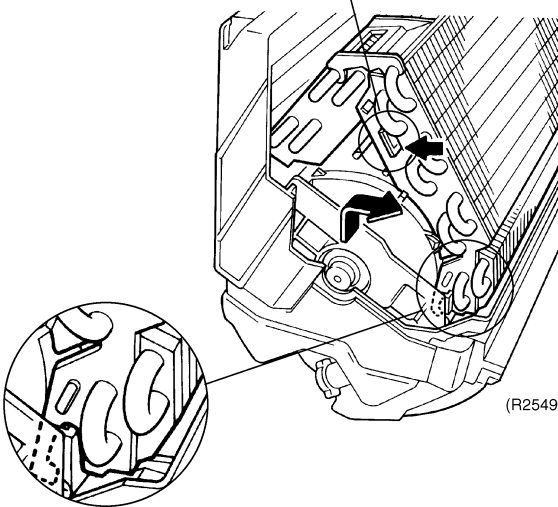
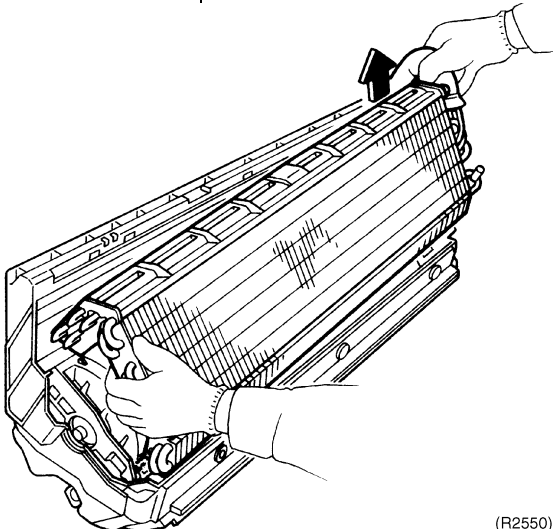
Step	Procedure	Procedure	Points
4	Disengage the hooks of the pipe retainer on the back.	 <p>(R2546)</p>	 <p>Pipe retainer (R2547)</p>
5	Pull auxiliary pipe forward to an angle of 10 to 20 degrees.	 <p>(R2548)</p>	<ul style="list-style-type: none"> Be careful to prevent pipe deformation.
6	Disengage hooks located right and left side, and pull heat exchanger forward. The hooks are symmetrically placed in the right and the left.	<p>This hook is located both side of heat exchanger. Press this hook to remove heat exchanger easily.</p>  <p>(R2549)</p>	<ul style="list-style-type: none"> Lifting the heat-exchanger slightly upward to the right, the left hook comes to be disengaged easily.  <p>(R2550)</p>

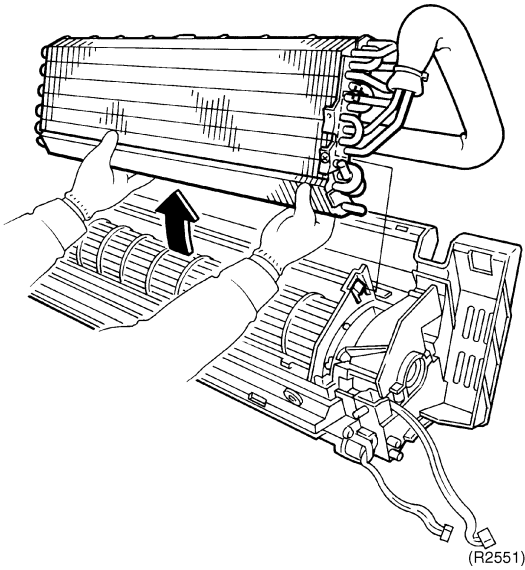
Step		Procedure	Points
7	Lift and remove heat exchanger.	 <p>(R2551)</p>	<p>Caution! When removing or re-installing heat exchanger, be sure to wear protective gloves or wrap heat exchanger with cloths. (Fins can cut fingers.)</p>

1.6 Install of Drain Plug

Procedure

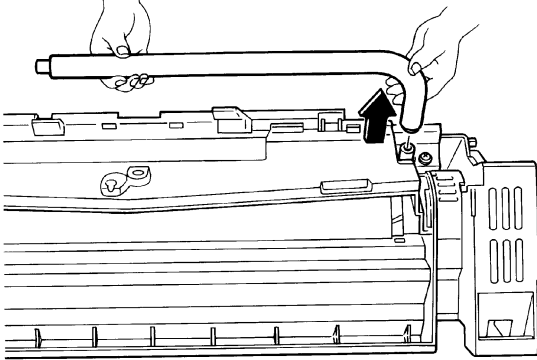
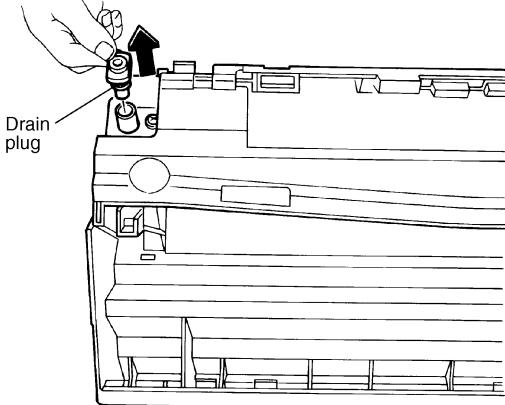
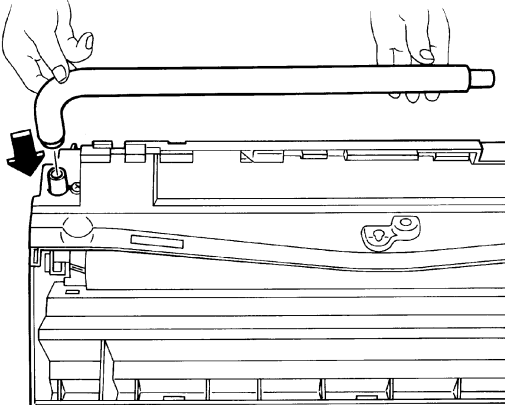
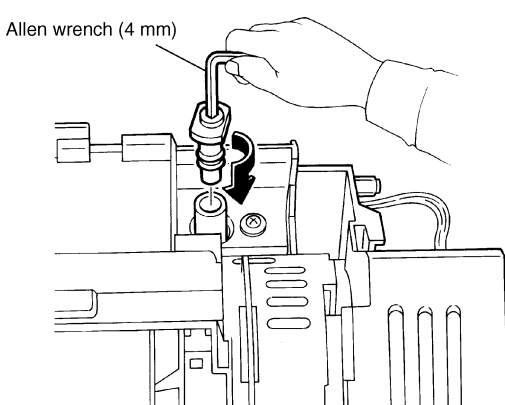

Warning Be sure to wait 10 minutes or more after turning off all power supplies before disassembling work.

Step	Procedure	Procedure	Points
1	Disconnect drain hose.	 <p>(R2552)</p>	<ul style="list-style-type: none"> ■ The drain pan is integrated with the bottom plate.
2	Pull out the drain plug in the left on the drain pan by hand.	 <p>(R2553)</p>	
3	Insert the drain hose,	 <p>(R2554)</p>	<ul style="list-style-type: none"> ■ Push it into the inner part firmly.
4	Push the drain plug into the right by Allen wrench.	 <p>(R2555)</p>	<ul style="list-style-type: none"> ■ Push it into the inner part firmly.

1.7 Removal of Fan Rotor and Fan Motor

Procedure

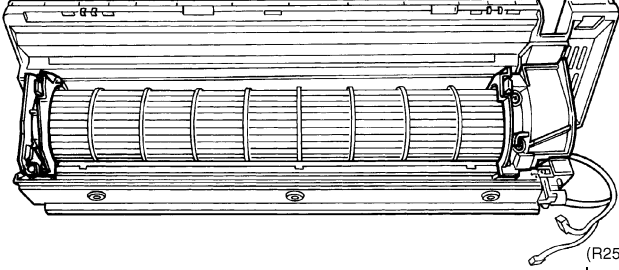
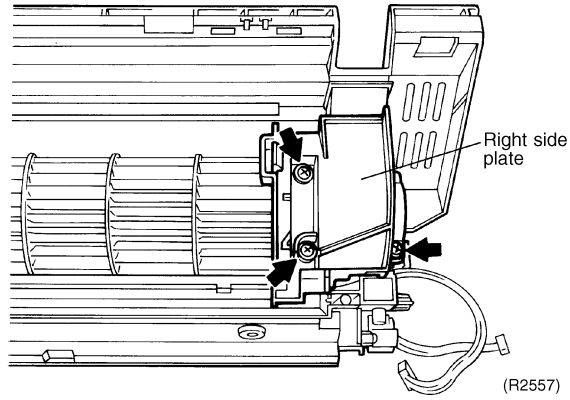

Warning Be sure to wait 10 minutes or more after turning off all power supplies before disassembling work.

Step	Procedure	Points
<p>■ Remove heat exchanger.</p>	 <p>(R2556)</p>	
<p>1</p>	<p>To remove right side plate, remove three screws.</p>  <p>Right side plate</p> <p>(R2557)</p>	

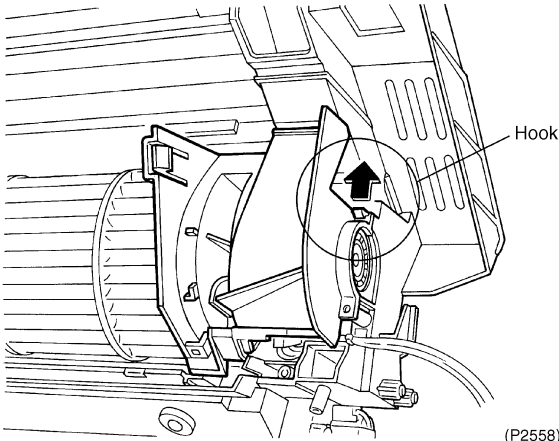
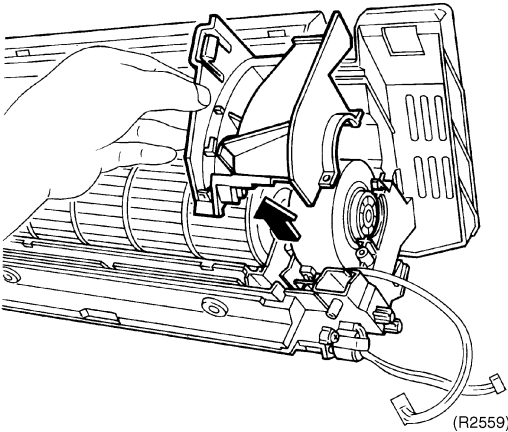
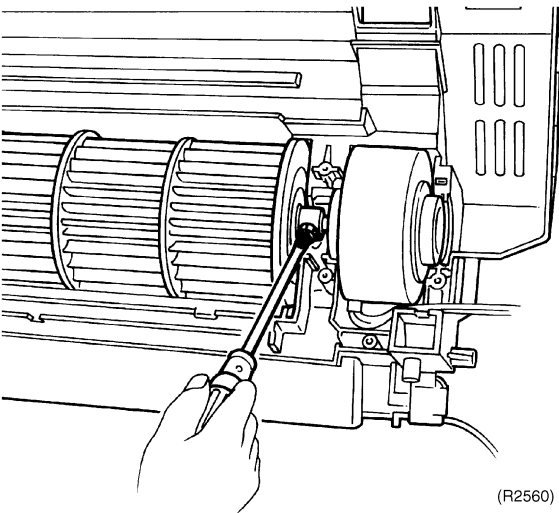
Step		Procedure	Points
2	Disengage hook.	 <p>(P2558)</p>  <p>(R2559)</p>	
3	Loosen the hexagon head set screw on the fan rotor.	 <p>(R2560)</p>	

Step	Procedure	Points
4	Remove the motor and fan rotor.	
5	Remove a screw on the left side plate.	

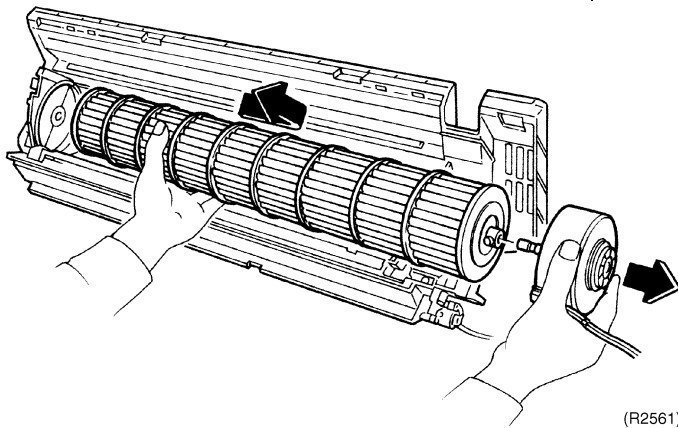

(R2561)

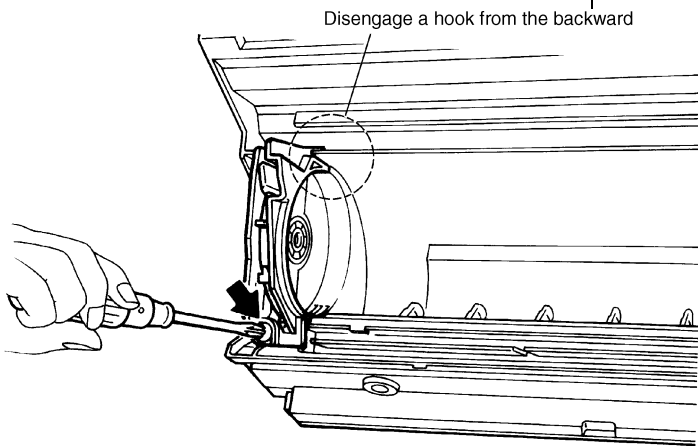

(R2562)

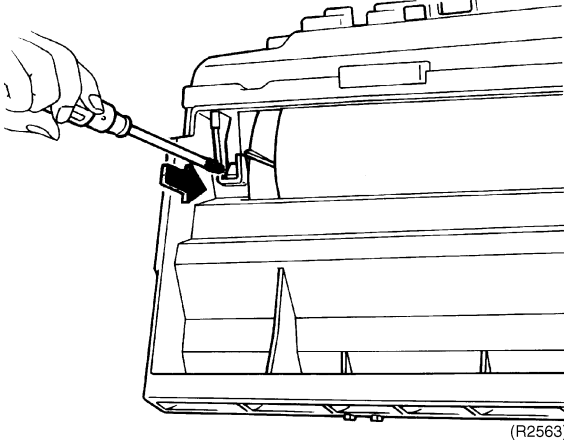
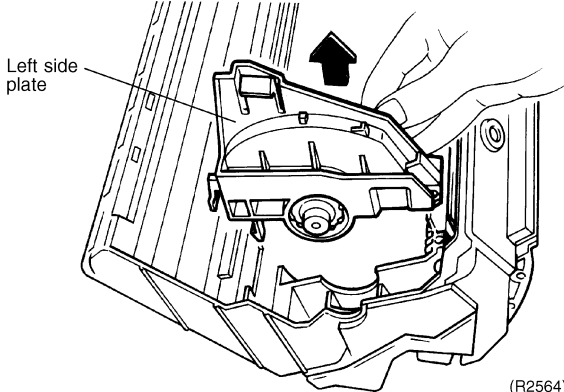
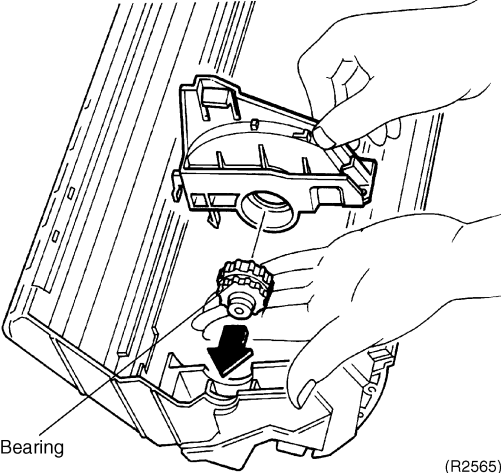
Step	Procedure	Points
6	<p>Disengage a hook from the backward.</p>  <p>(R2563)</p>  <p>Left side plate</p> <p>(R2564)</p>	
7	<p>Since the fan bearing is made of rubber, push it strongly off from the inside. The bearing can be removed just as the left side plate is attached with.</p>  <p>Bearing</p> <p>(R2565)</p>	

2. Outdoor Unit / RK(X)S-C, ARK(X)S-C

2.1 Removal of Panels and Fan Motor

Procedure



Warning Be sure to wait 10 minutes or more after turning off all power supplies before disassembling work.

Step	Procedure	Points
<p>1. Features</p> <p>1 Loosen the screw of the stop valve cover. Pull down the stop valve cover and remove it.</p>	<p>Handle</p> <p>(R3235)</p> <p>Outdoor air thermistor</p> <p>(R3236)</p> <p>Stop valve cover</p> <p>(R3237)</p> <p>Shelter</p> <p>Hooks</p> <p>(R3238)</p>	<ul style="list-style-type: none"> ■ Take care not to cut your finger by the fins of the heat exchanger. ■ The stop valve cover is united with the shelter. ■ When reassembling, make sure to fit the 5 hooks.

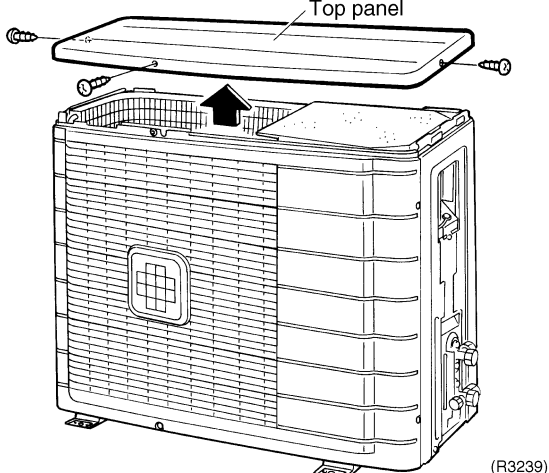
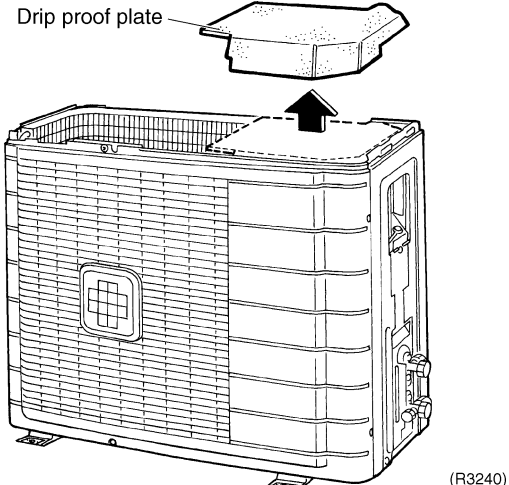
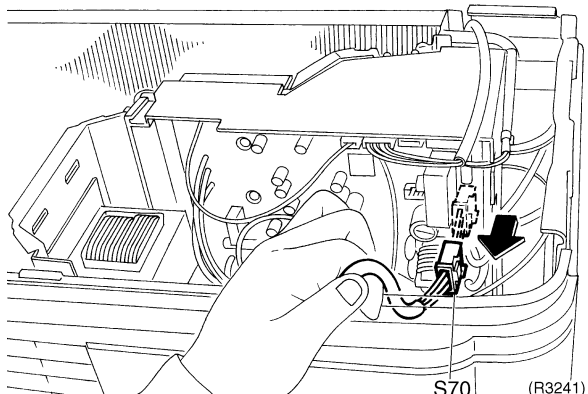
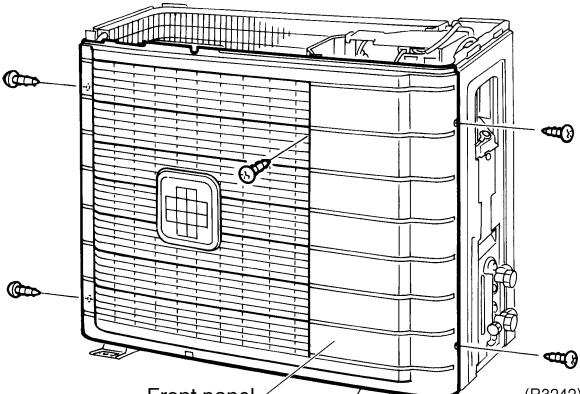
Step	Procedure	Points
2. Remove the panels.		
1	<p>Loosen the 3 screws (front, right, left) and lift the top panel.</p>  <p style="text-align: right;">(R3239)</p>	
2	<p>Remove the drip proof plate.</p>  <p style="text-align: right;">(R3240)</p>	
3	<p>Disconnect the connector for fan motor (S70).</p>  <p style="text-align: right;">(R3241)</p>	<p>■ The fan motor is united with the front panel.</p>
4	<p>Loosen the 5 screws of the front panel.</p>  <p style="text-align: right;">(R3242)</p>	

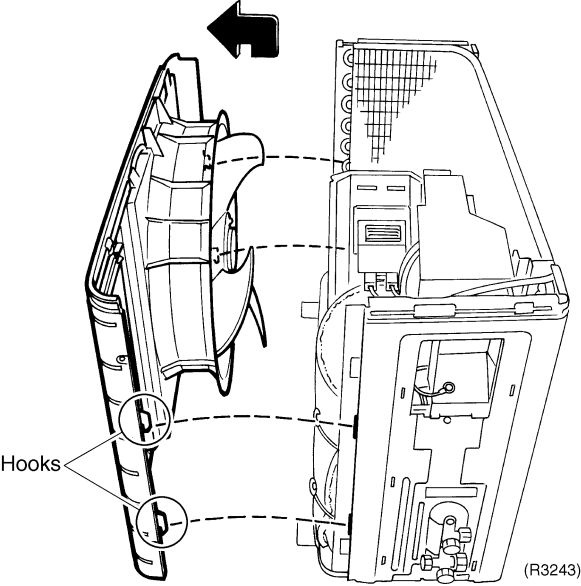
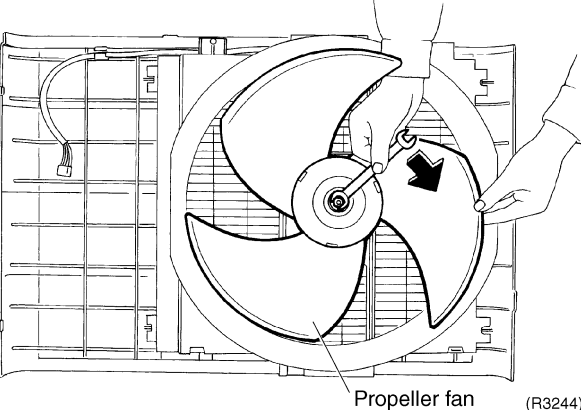
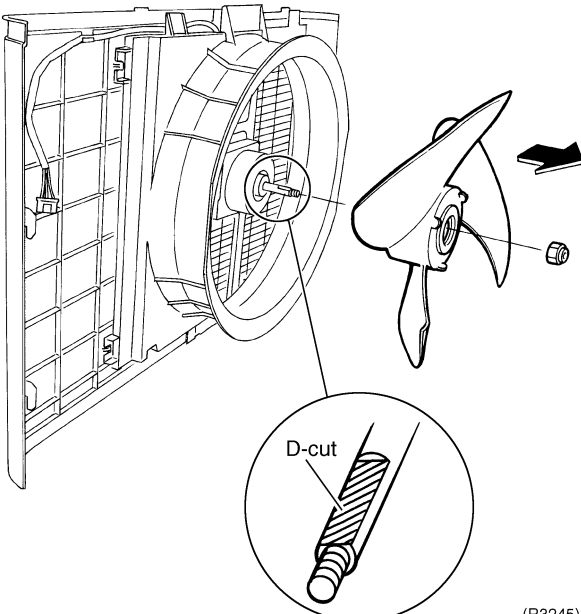
Step	Procedure	Points
5	<p>Undo the hooks. Pull and remove the front panel.</p> 	<ul style="list-style-type: none"> ■ The front panel has 4 hooks. ■ The fan motor is united with the front panel.
<p>3. Remove the fan motor.</p> <p>1</p> <p>2</p>	<p>1 Unscrew the washer-fitted nut (M10) of the propeller fan with a spanner.</p>  <p>2 Remove the propeller fan.</p> 	<ul style="list-style-type: none"> ■ The screw has reverse winding. ■ Align ▼ mark of the propeller fan with D-cut section of the motor shaft when reassembling.

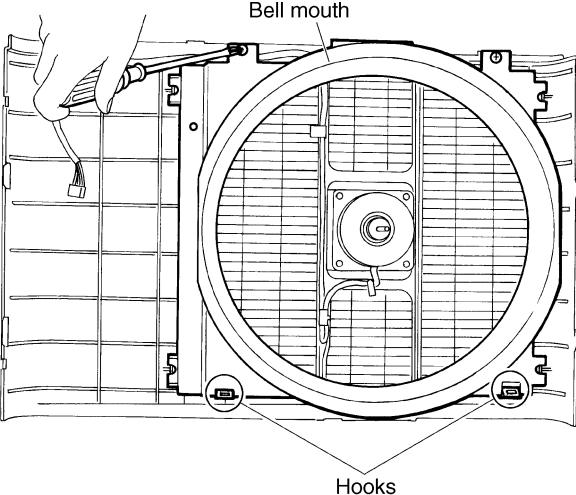
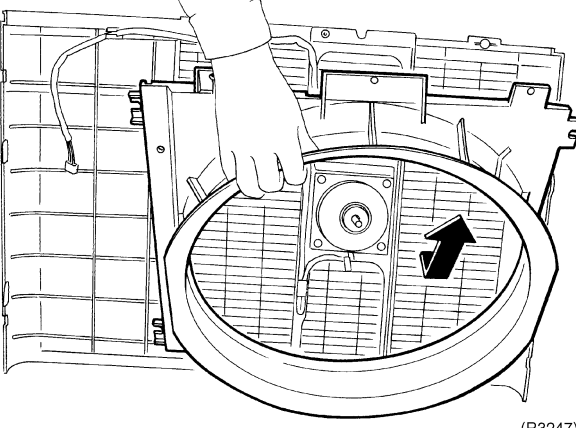
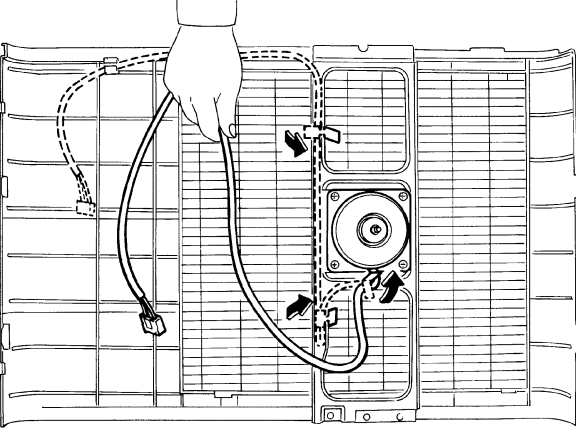
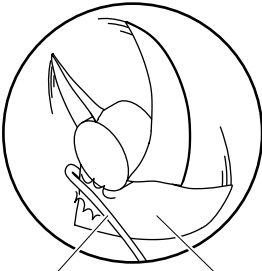
Step	Procedure	Points
<p>3</p> <p>Loosen the 2 screws and lift the bell mouth to undo the hooks. Remove the bell mouth.</p>	 <p>Bell mouth</p> <p>Hooks</p> <p>(R3246)</p>  <p>(R3247)</p>	
<p>4</p> <p>Loosen the fixing hooks and release the lead wire.</p>	 <p>(R3248)</p>	<ul style="list-style-type: none"> Put the lead wire through the back of the motor when reassembling. (so as not to be entangled with the propeller fan)  <p>Lead wire</p> <p>Propeller fan</p> <p>(R3249)</p>

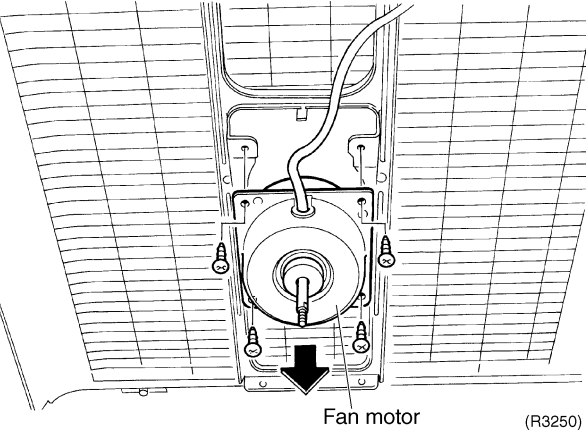
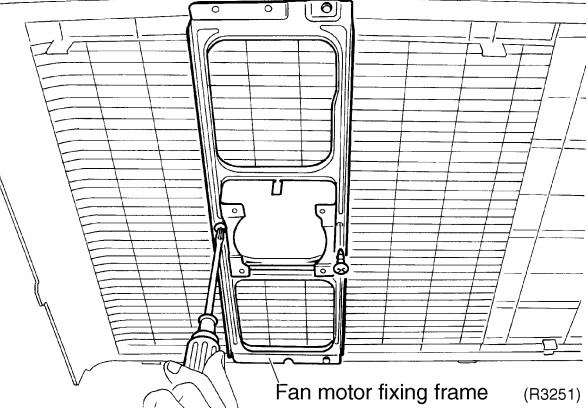
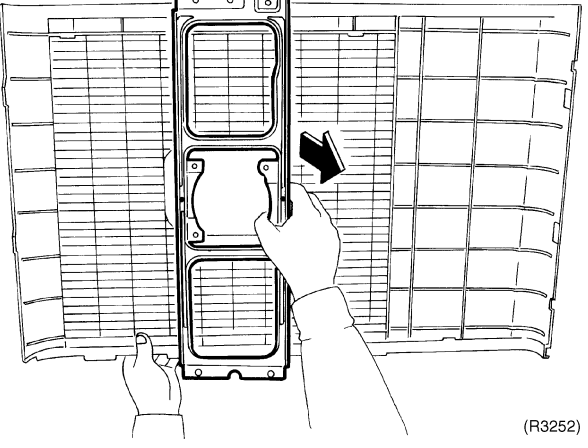
Step	Procedure	Points
5	<p>Loosen the 4 screws to remove the fan motor.</p> 	<ul style="list-style-type: none"> ■ M4×16 ■ DC fan motor
6	<p>Loosen the 2 screws to remove the fan motor fixing frame.</p>  	

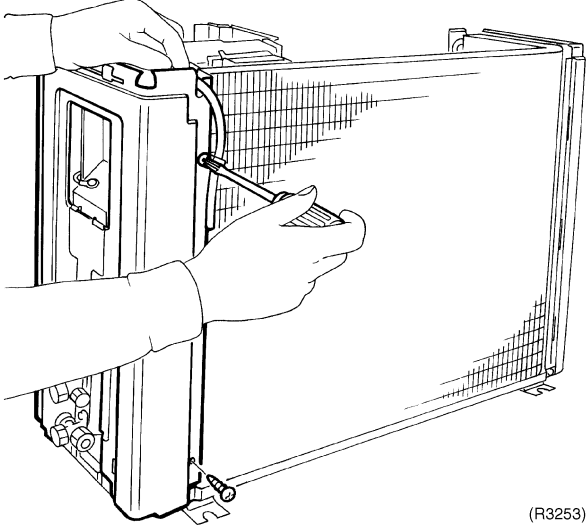
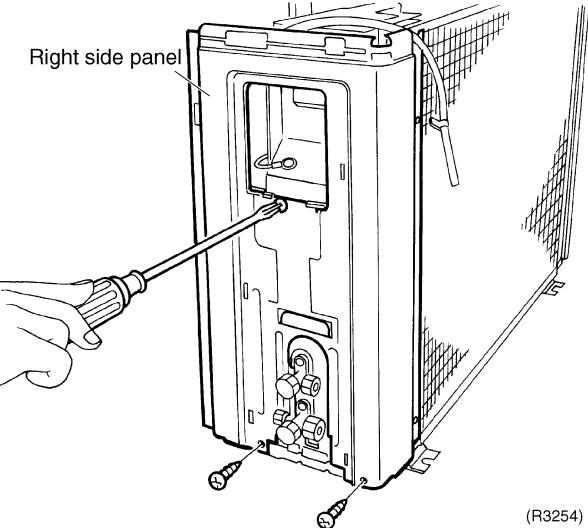
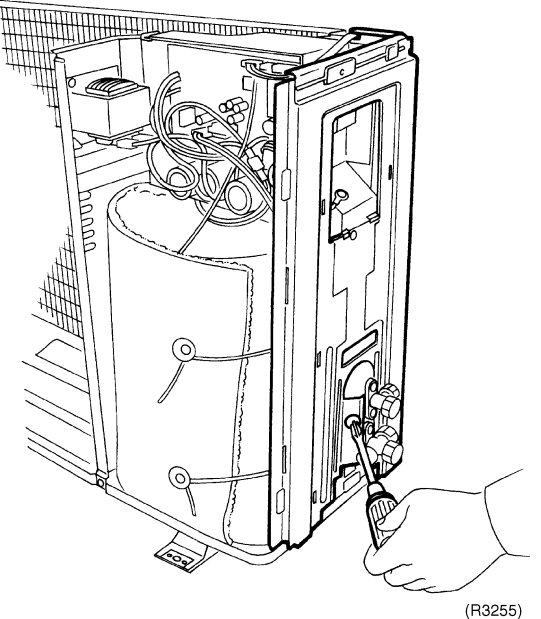
Step	Procedure	Points
4. Remove the right side panel.		
1	<p>Loosen the 2 screws on the rear side.</p>  <p>(R3253)</p>	
2	<p>Loosen the 3 screws on the right side.</p>  <p>Right side panel</p> <p>(R3254)</p>	
3	<p>Loosen the screw and lift the connection port to remove.</p>  <p>(R3255)</p>	

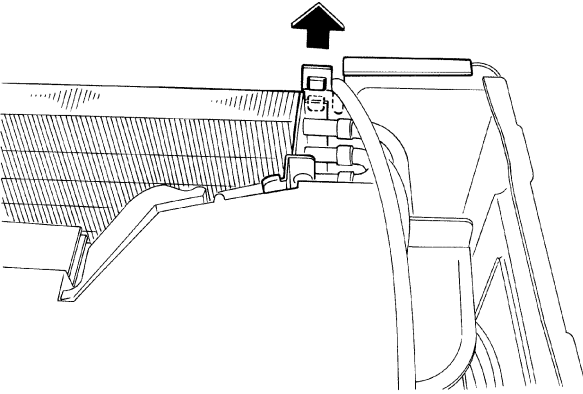
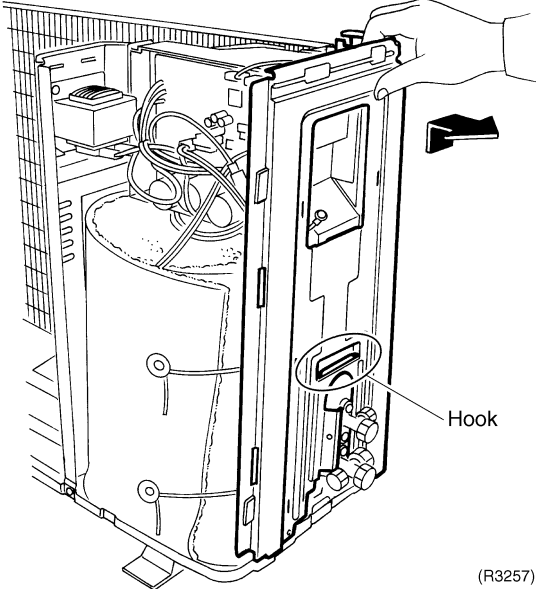
Step	Procedure	Points
	 <p>(R3256)</p>  <p>Hook</p> <p>(R3257)</p>	<ul style="list-style-type: none"> ■ When reassembling, make sure to fit the hook.

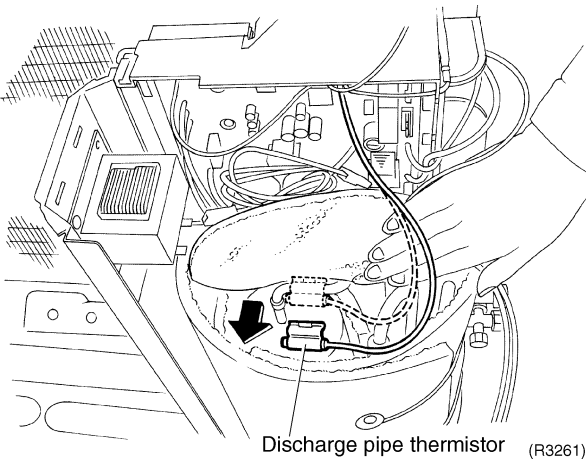
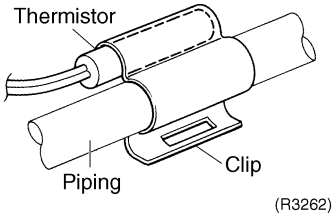
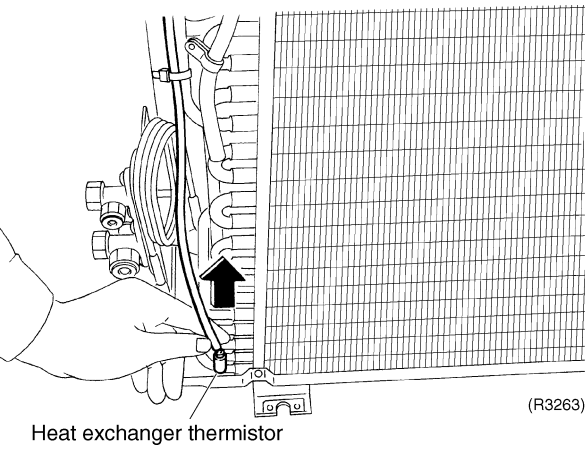
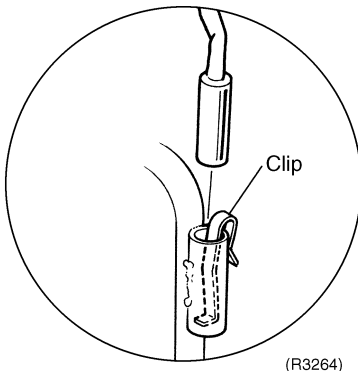
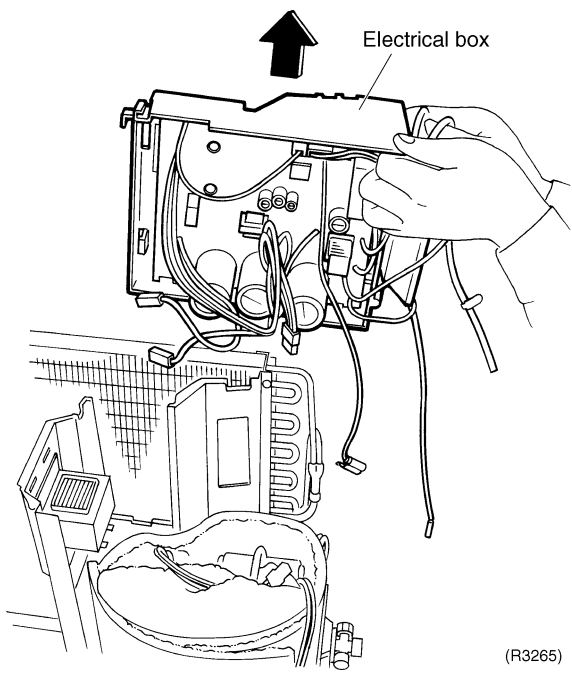
Step	Procedure	Procedure	Points
4	Release the discharge pipe thermistor.		<ul style="list-style-type: none"> ■ Pay attention so as not to lose the clip for thermistor. 
5	Release the heat exchanger thermistor.		<ul style="list-style-type: none"> ■ Pay attention so as not to lose the clip. 
6	Lift and remove the electrical box.		

2.3 Removal of Reactor and Partition Plate

Procedure

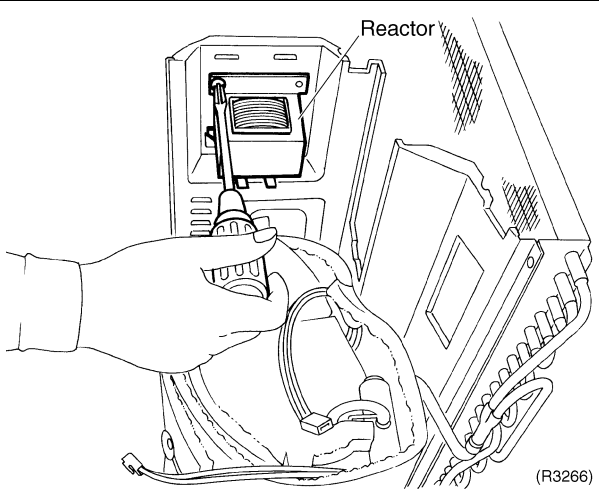
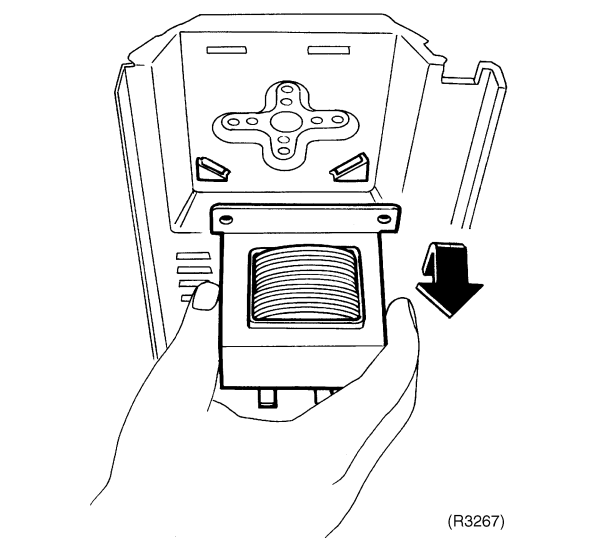
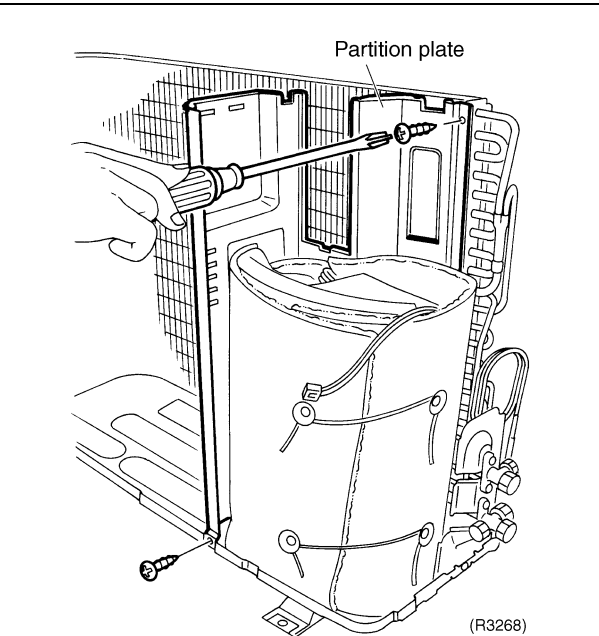

Warning Be sure to wait 10 minutes or more after turning off all power supplies before disassembling work.

Step	Procedure	Points
<ul style="list-style-type: none"> ■ Remove the outer panels. ■ Remove the electrical box. 	 <p style="text-align: right;">(R3266)</p>  <p style="text-align: right;">(R3267)</p>	
<p>1. Remove the reactor.</p>		
<p>1</p>	<p>Loosen the screw. Lift and remove the reactor.</p>	
<p>2. Remove the partition plate.</p>	 <p style="text-align: right;">(R3268)</p>	
<p>1</p>	<p>Loosen the 2 screws.</p>	

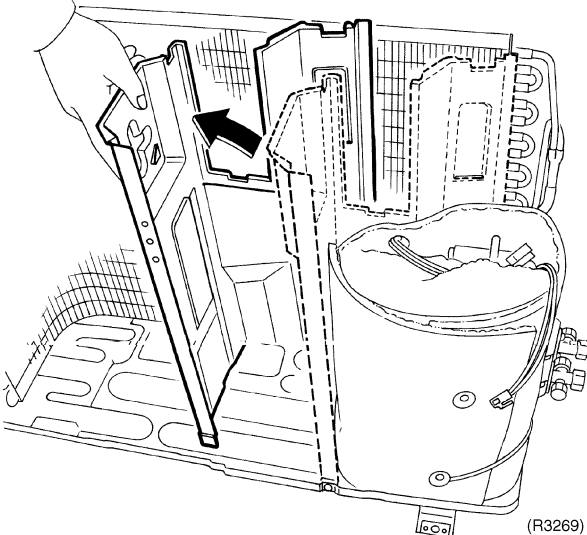
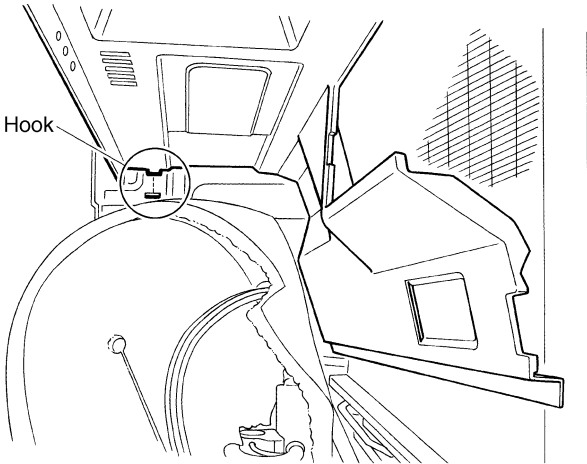
Step	Procedure	Points
<p>2</p>	<p>The partition plate has a hook on the lower side. Lift and pull the partition plate to remove.</p>  <p>(R3269)</p>  <p>(R3270)</p>	<ul style="list-style-type: none"> ■ When reassembling, fit the lower hook into the bottom frame.

2.4 Removal of Sound Blanket

Procedure



Warning Be sure to wait 10 minutes or more after turning off all power supplies before disassembling work.

Step	Procedure	Points
<ul style="list-style-type: none"> ■ Remove the outer panels. ■ Remove the electrical box. 	<p style="text-align: right;">(R3271)</p>	
<p>1. Remove the sound blanket.</p>	<p>1 Untie the strings and open the sound blanket.</p> <p>2 Lift and remove the sound blanket (body) as it is opened.</p> <p style="text-align: right;">(R3272)</p>	<ul style="list-style-type: none"> ■ Since the piping ports on the sound blanket are torn easily, remove the blanket carefully.
<p>3 Lift and remove the sound blanket (top).</p>	<p style="text-align: right;">(R3273)</p>	

Step	Procedure	Points
4	Pull the sound blanket (inner) out.	<ul style="list-style-type: none"> ■ Since the piping ports on the sound blanket are torn easily, remove the blanket carefully.
5	Pull the sound blanket (bottom) out.	

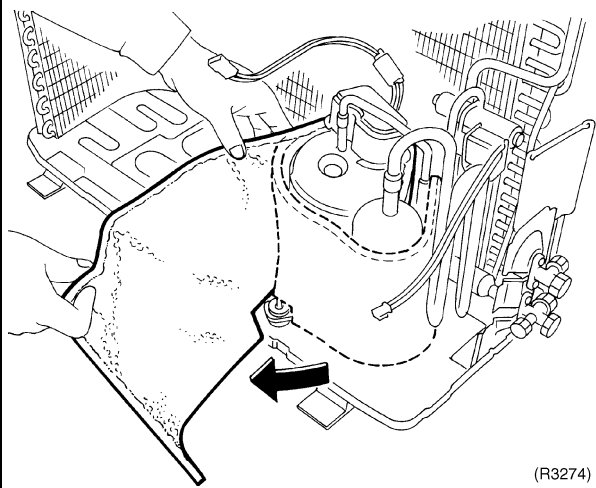

(R3274)

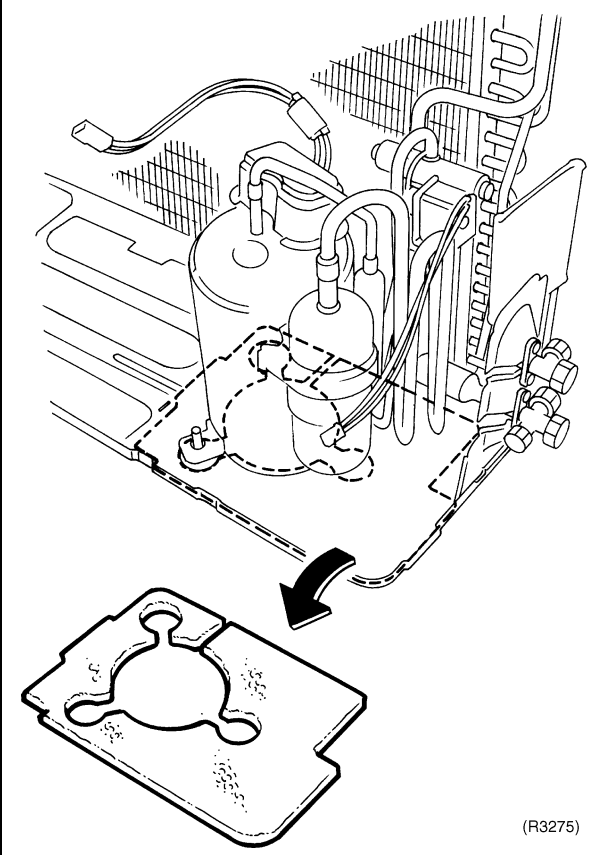

(R3275)

2.5 Removal of Four Way Valve

Procedure

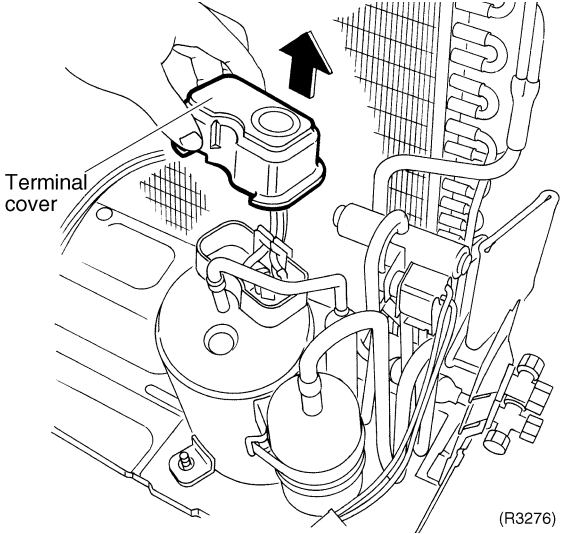
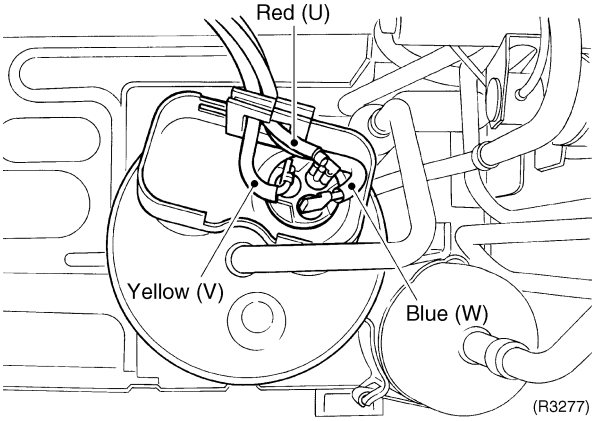
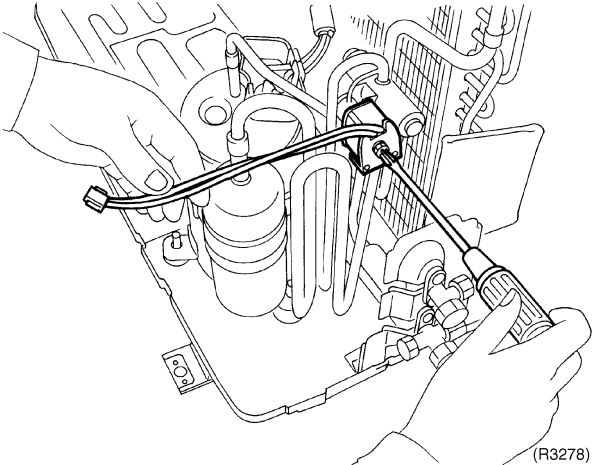

Warning Be sure to wait 10 minutes or more after turning off all power supplies before disassembling work.

Step	Procedure	Points
1. Remove the peripheries.	<ul style="list-style-type: none"> Remove the four way valve and the sheets of putty so as not to burn them. 	
1 Remove the terminal cover.	 <p>Terminal cover</p> <p>(R3276)</p>  <p>Red (U)</p> <p>Yellow (V)</p> <p>Blue (W)</p> <p>(R3277)</p>	<ul style="list-style-type: none"> Be careful so as not to burn the compressor terminals or the name plate. <p>Make a note.</p>
2 Loosen the screw of the four way valve coil.	 <p>(R3278)</p>	

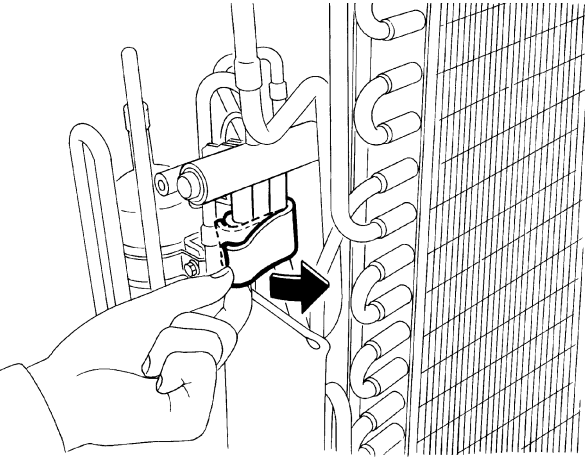
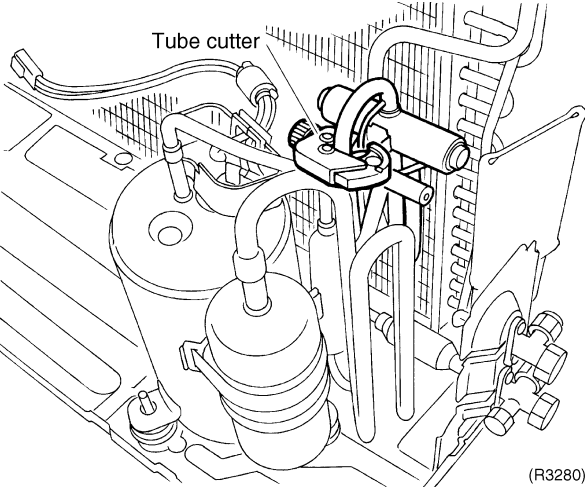
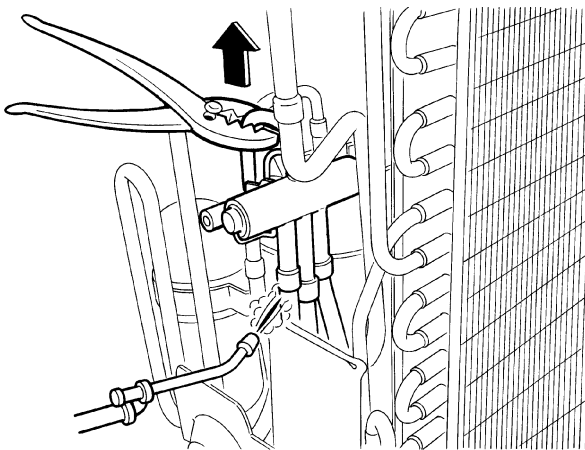
Step	Procedure	Procedure	Points
3	<p>Remove the sheets of putty. Cut the pipe with a tube cutter.</p>	 <p>(R3279)</p>  <p>(R3280)</p>	
4	<p>Heat up the brazed part and withdraw the piping with pliers.</p>	 <p>(R3281)</p>	<ul style="list-style-type: none"> ■ Provide a protective sheet or a steel plate so that the brazing flame cannot influence peripheries. ■ Be careful so as not to break the pipes by pressing it excessively by pliers when withdrawing it.

2.6 Removal of Compressor

Procedure

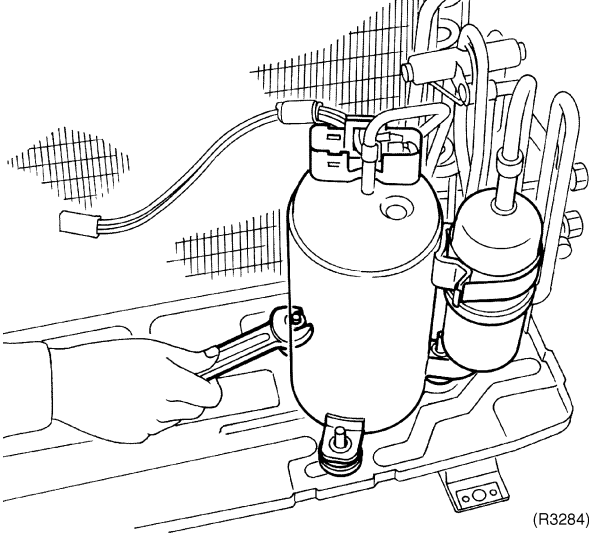
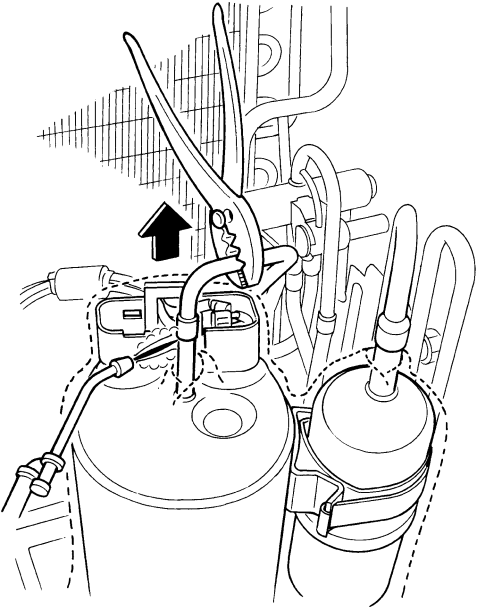

Warning Be sure to wait 10 minutes or more after turning off all power supplies before disassembling work.

Step	Procedure	Points
<p>1. Remove the compressor.</p> <p>1 Unscrew the nut of the compressor.</p> <ul style="list-style-type: none"> ■ Before working, make sure that the refrigerant is empty in the circuit. ■ Be sure to apply nitrogen replacement when heating up the brazed part. <p>2 Heat up the brazed part of the discharge side and disconnect.</p>	 <p style="text-align: right;">(R3284)</p>  <p style="text-align: right;">(R3285)</p>	<p>Warning Ventilate when refrigerant leaks during the work. (If refrigerant contacts fire, it will cause to arise toxic gas.)</p> <ul style="list-style-type: none"> ■ Provide a protective sheet or a steel plate so that the brazing flame cannot influence peripheries. ■ Be careful so as not to burn the compressor terminals or the name plate. ■ Be careful so as not to burn the heat exchanger fin. <p>Warning Since it may happen that refrigeration oil in the compressor will catch fire, prepare wet cloth so as to extinguish fire immediately.</p> <p>In case of the difficulty with gas brazing machine</p> <ol style="list-style-type: none"> 1. Disconnect the brazed part where is easy to disconnect and restore. 2. Cut pipes on the main unit by a miniature copper tube cutter in order to make it easy to disconnect. <p>Cautions for restoration</p> <ol style="list-style-type: none"> 1. Restore the piping by non-oxidation brazing. 2. It is required to prevent the carbonization of the oil inside the four way valve and the deterioration of the gaskets affected by heat. For the sake of this, wrap the four way valve with wet cloth and provide water so that the cloth will not be dried and avoid excessive heating. (Keep below 120°C) <p>i Note: Do not use a metal saw for cutting pipes by all means because the sawdust come into the circuit.</p>

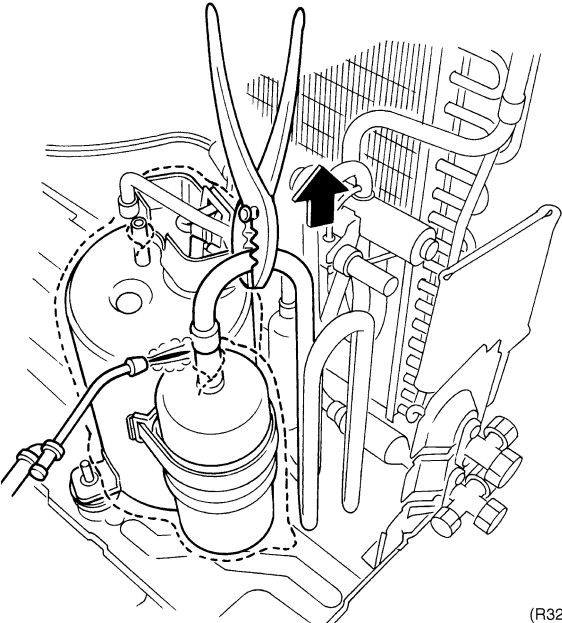
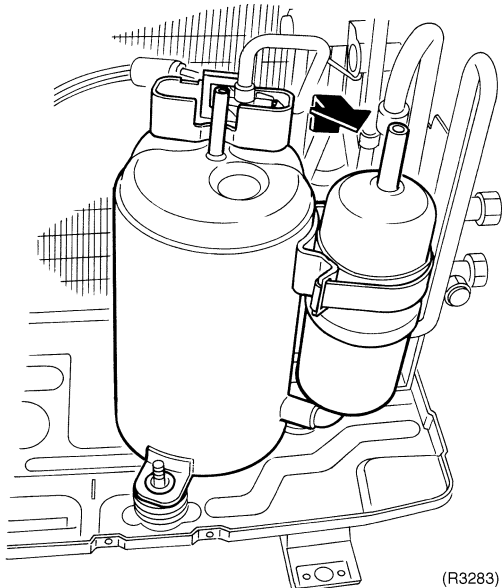
Step	Procedure	Points
3	<p>Heat up the brazed part of the suction side and disconnect.</p>  <p>(R3282)</p>	
4	<p>Lift the compressor up and remove it.</p>  <p>(R3283)</p>	

2.7 Removal of PCB

Procedure

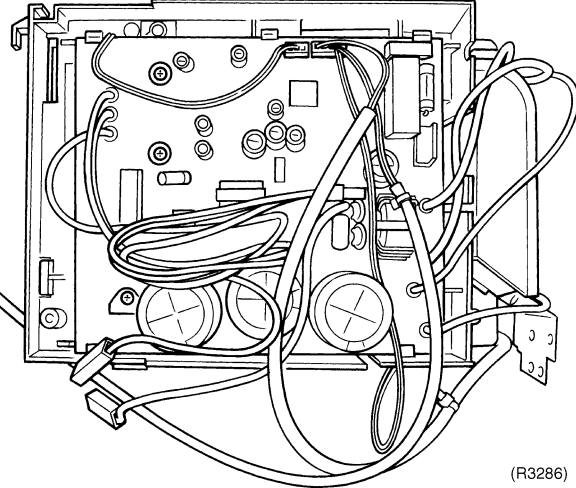
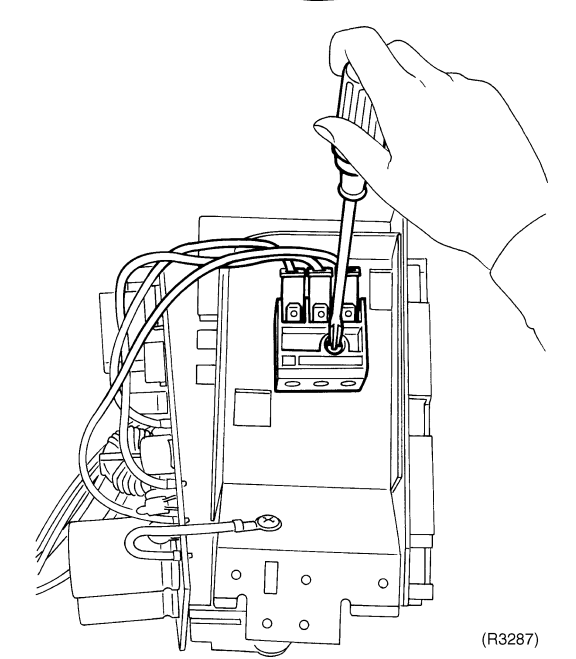
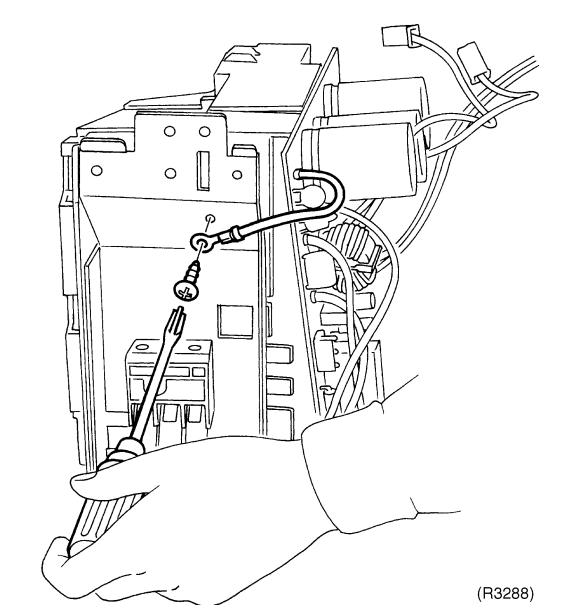

Warning Be sure to wait 10 minutes or more after turning off all power supplies before disassembling work.

Step	Procedure	Points
1. Remove the PCB.		
1 Feature of the PCB	 <p style="text-align: right;">(R3286)</p>	<ul style="list-style-type: none"> ■ You can remove the PCB when you disconnect the read wires on the terminal board without removing the electrical box. ■ PbF (Pb free brazing) is adopted.
2 Loosen the screw on the terminal board.	 <p style="text-align: right;">(R3287)</p>	
3 Release the earth terminal.	 <p style="text-align: right;">(R3288)</p>	

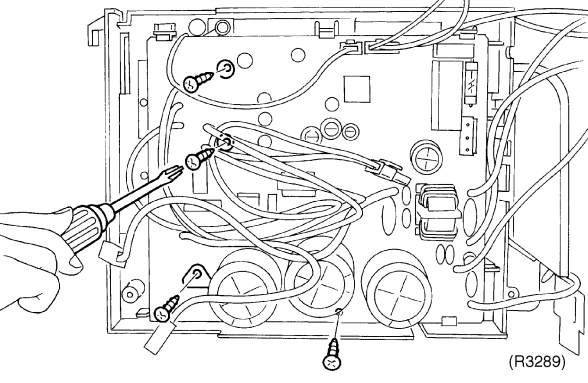
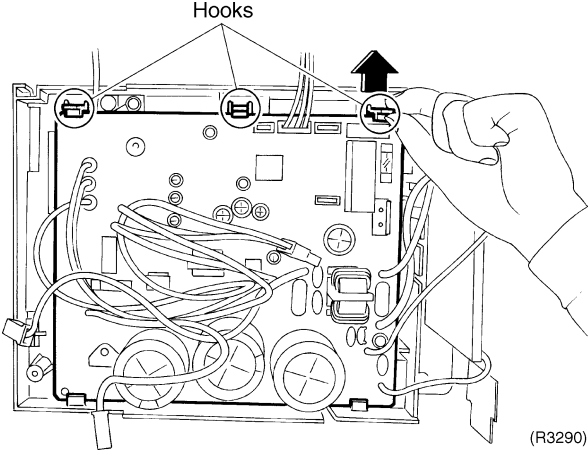
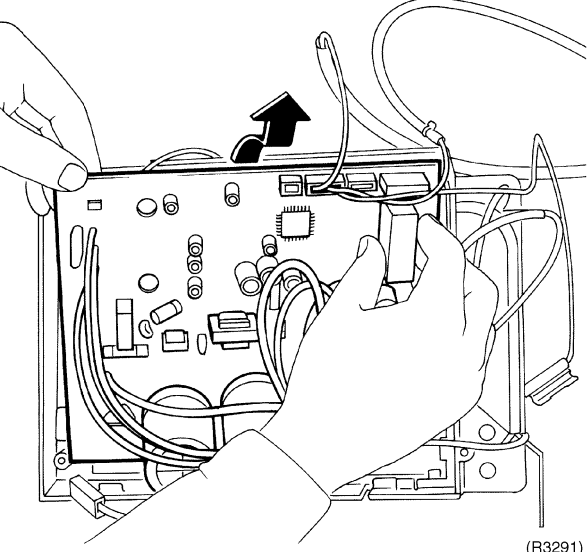
Step	Procedure	Procedure	Points
4	Loosen the 4 screws.	 <p>(R3289)</p>	
5	Undo the 3 hooks on the upper side.	 <p>Hooks</p> <p>(R3290)</p>	
6	Lift and pull out the PCB.	 <p>(R3291)</p>	

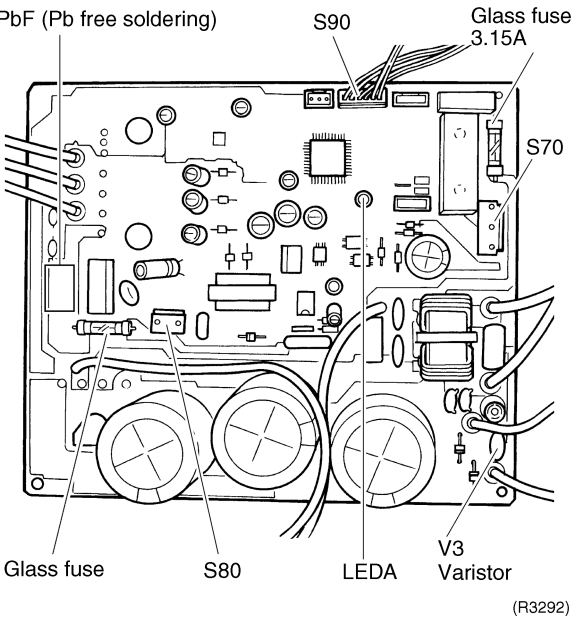
Step	Procedure	Points
7	<p>Feature of the PCB S70: fan motor S80: four way valve S90: thermistor (outdoor air, heat exchanger, discharge pipe)</p>  <p>PbF (Pb free soldering) S90 Glass fuse 3.15A</p> <p>Glass fuse S80 LEDA V3 Varistor</p> <p>(R3292)</p>	

3. Outdoor Unit / RK(X)H-C, ARK(X)H-C, R(Y)N-C

3.1 Removal of External Panels

Procedure



Warning

Be sure to wait 10 minutes or more after turning off all power supplies before disassembling work.

Step	Procedure	Procedure	Points
1	The stop valve cover can be removed when the fixing screw is removed.	<p>(R4025)</p> <p>(R4026)</p> <p>(R1451)</p>	<ul style="list-style-type: none"> ■ As hooks are provided, slide the cover downward to remove. ■ The forced cooling operation in the pumping down mode can be carried out by pushing the ON / OFF button on the indoor unit for 5 seconds.

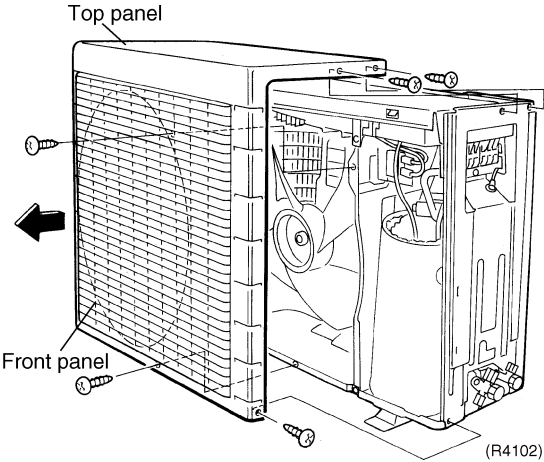
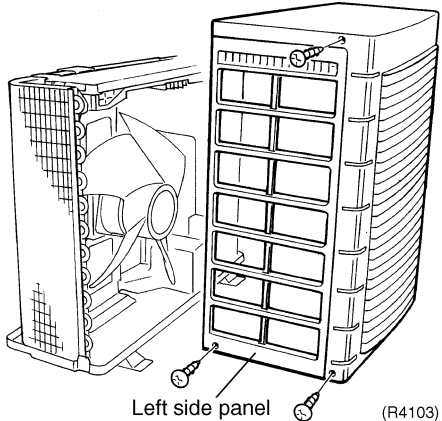
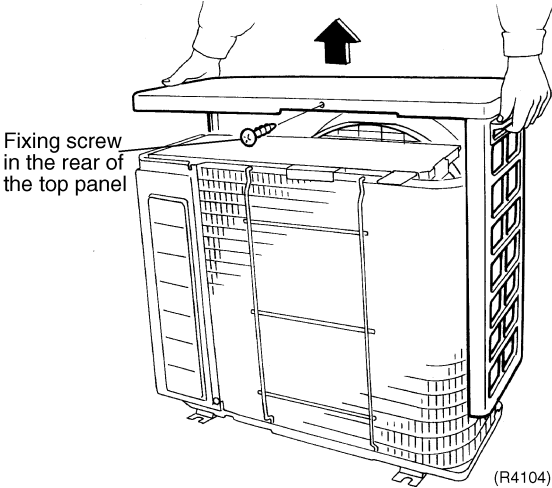
Step	Procedure	Procedure	Points
2	The top panel and the front panel are constructed in a monoblock. Remove the 3 screws on the right side and the 2 screws on the front panel.	 <p>Top panel</p> <p>Front panel</p> <p>(R4102)</p>	
3	Remove the 3 screws on the left side.	 <p>Left side panel</p> <p>(R4103)</p>	
4	Remove the fixing screw in the rear of the top panel. Once lift the top panel and then remove it forward.	 <p>Fixing screw in the rear of the top panel</p> <p>(R4104)</p>	<ul style="list-style-type: none"> ■ The left side panel and the bell mouth can be removed all at once. ■ When restoring the top panel, move it horizontally and get it down for the easy work.

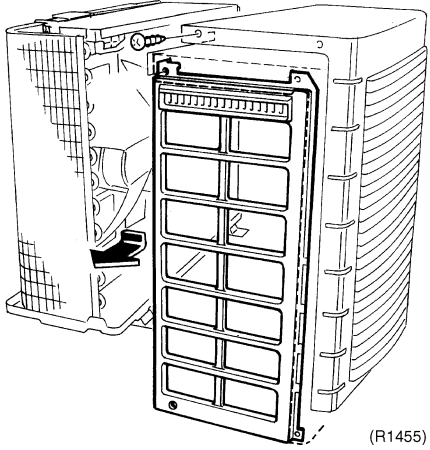
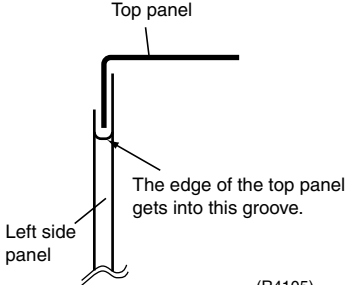
Step	Procedure	Points
<p>5</p>	<p>The front panel and the left side panel can be separated when the fixing screw is removed.</p>  <p>(R1455)</p>	<p>■ Sectional view at the front.</p>  <p>(R4105)</p>

3.2 Removal of Bell mouth

Procedure



Warning Be sure to wait 10 minutes or more after turning off all power supplies before disassembling work.

Step	Procedure	Points
<p>1 The bell mouth is attached to the front plate with 2 screws and 4 hooks.</p>	<p>(R4094)</p>	
<p>2 Remove the 2 screws and undo the 4 hooks to release the bell mouth.</p>	<p>(R4095)</p>	<ul style="list-style-type: none"> Slide the bell mouth in the arrow direction to disengage the hook B.

3.3 Removal of PCB and Electrical Box

Procedure

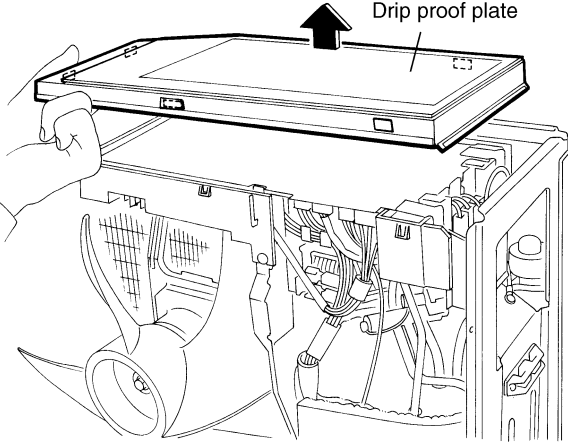
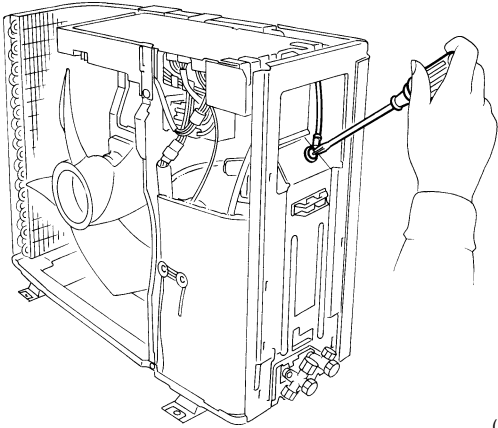
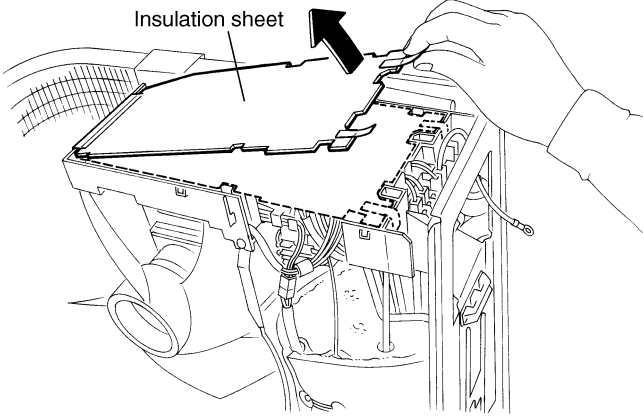

Warning Be sure to wait 10 minutes or more after turning off all power supplies before disassembling work.

Step	Procedure	Points
<p>1. Remove the drip proof plate.</p> <p>1 Undo the 5 hooks and remove the drip proof plate.</p>	 <p>(R4027)</p>	<ul style="list-style-type: none"> ■ The drip proof plate has 5 hooks. ■ Be sure to restore the drip proof plate and to avoid losing or damaging it.
<p>2. Remove the PCB.</p> <p>1 Disconnect the earth terminal.</p> <p>2 Remove the insulation sheet.</p>	 <p>(R4028)</p>  <p>(R4029)</p>	

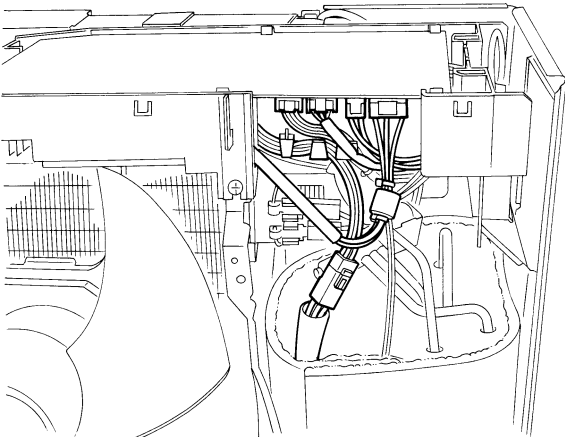
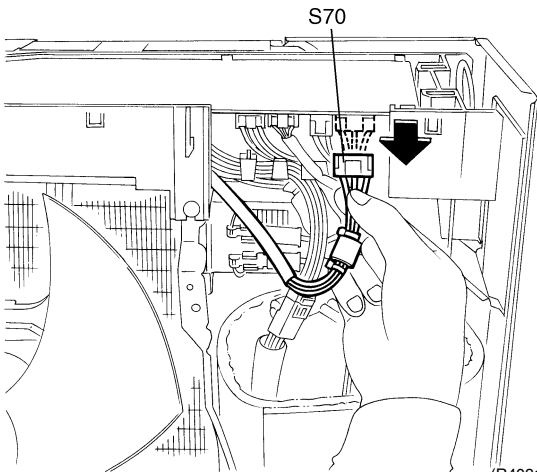
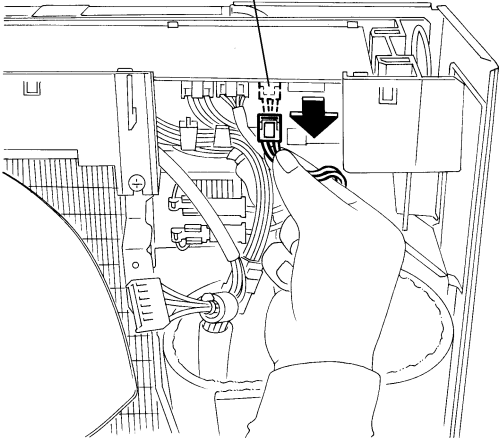
Step	Procedure	Points
3	<p>Disconnect the fan motor connector. (S70)</p>  <p>(R4030)</p>  <p>(R4031)</p>	
4	<p>Disconnect the four way valve connector. (S80)</p>  <p>(R4032)</p>	

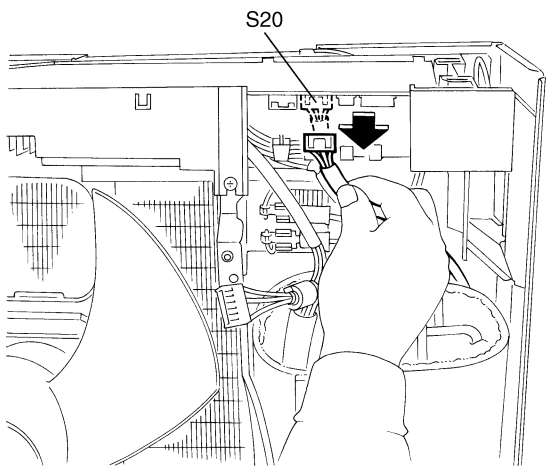
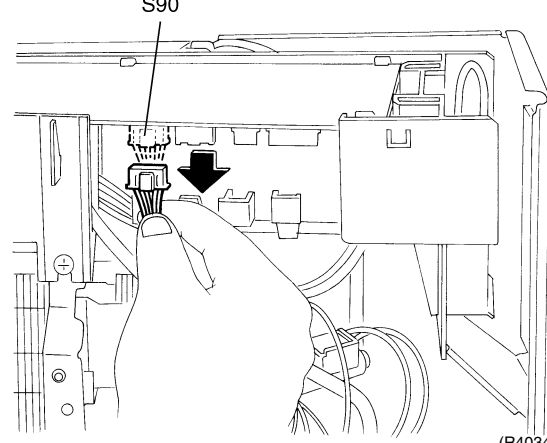
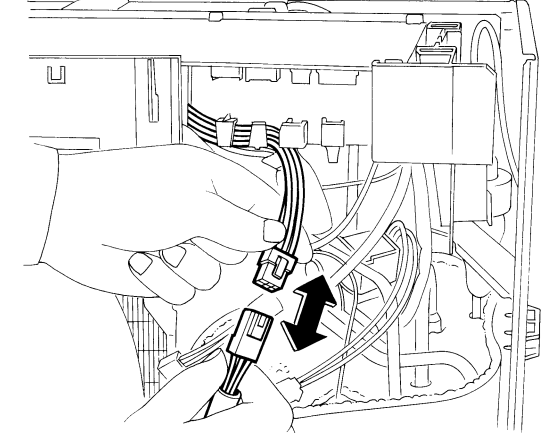
Step	Procedure	Procedure	Points
5	Disconnect the electronic expansion valve connector. (S20)	 <p style="text-align: right;">(R4033)</p>	
6	Disconnect the thermistor connector. (S90) <ul style="list-style-type: none"> ■ outdoor air ■ heat exchanger ■ discharge pipe 	 <p style="text-align: right;">(R4034)</p>	
7	Disconnect the relay harness.	 <p style="text-align: right;">(R4035)</p>	

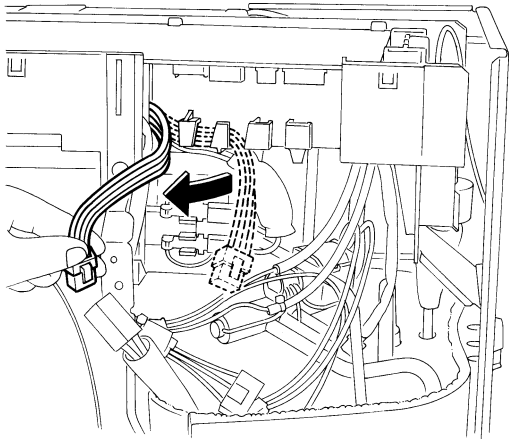
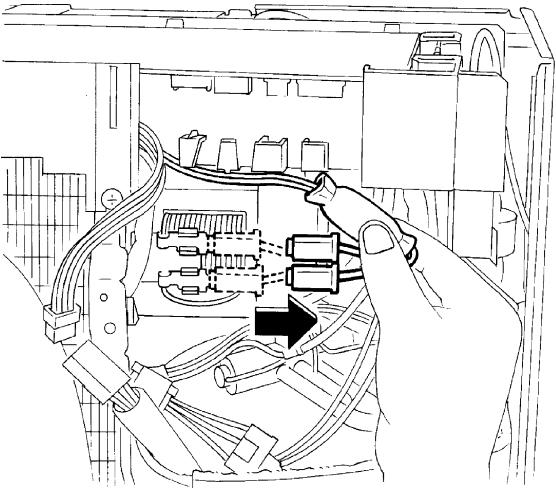
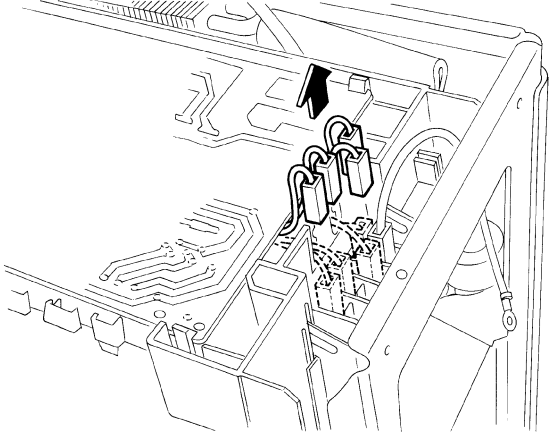
Step	Procedure	Points
	 <p data-bbox="999 723 1059 745">(R4036)</p>	
<p data-bbox="156 770 416 831">8 Disconnect the 2 reactor harnesses.</p>	 <p data-bbox="1015 1310 1075 1332">(R4037)</p>	
<p data-bbox="156 1361 448 1422">9 Disconnect the 4 wire harnesses.</p>	 <p data-bbox="1015 1854 1075 1877">(R4038)</p>	

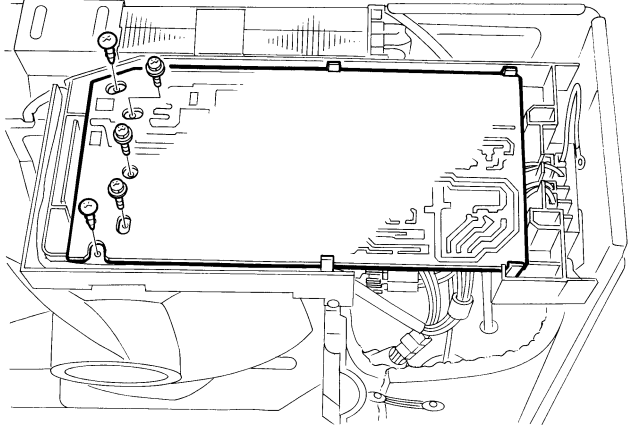
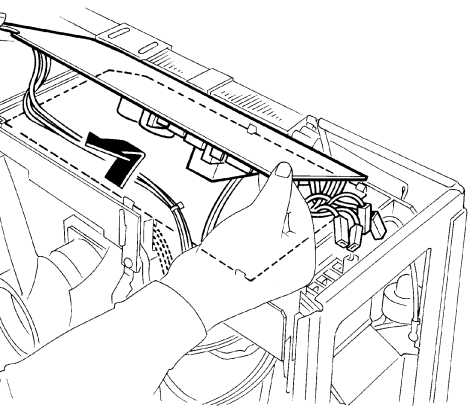
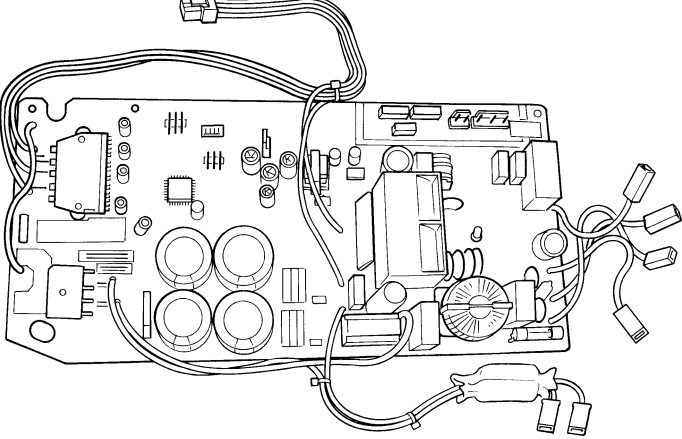
Step	Procedure	Points
10	<p>Remove the 5 screws fixing the PCB.</p> 	
11	<p>Undo the 4 hooks and the PCB can be disengaged.</p> 	<p>(R4039)</p> <ul style="list-style-type: none"> ■ The PCB has 4 hooks.
12	<p>Control PCB (outdoor unit)</p> 	<p>(R4041)</p>

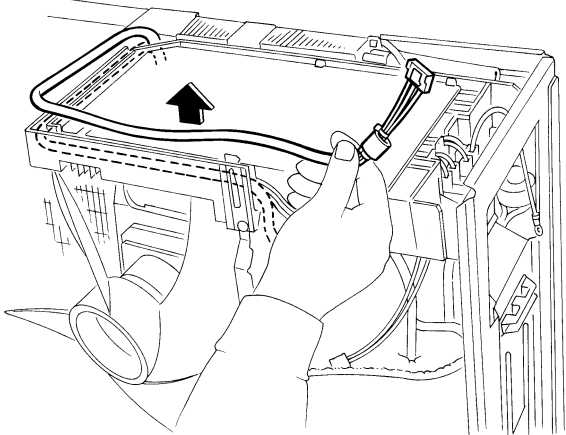
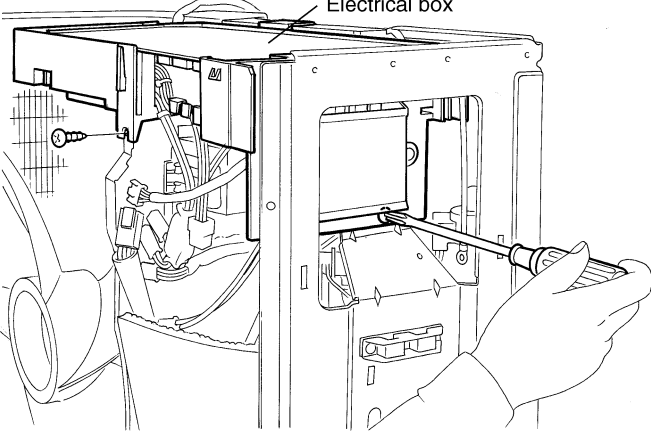
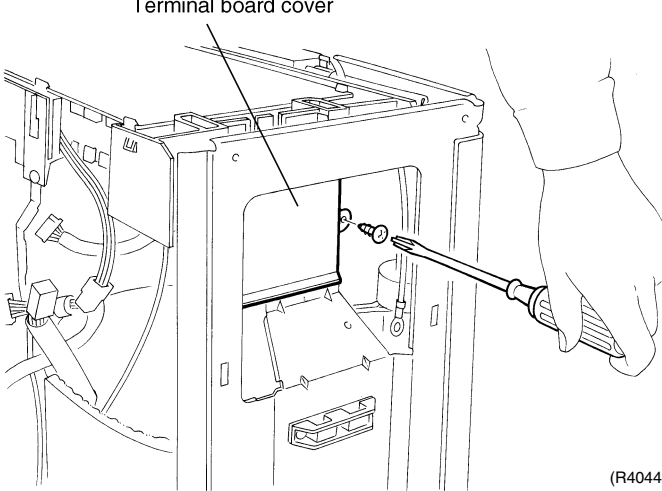
Step	Procedure	Points
3.	Remove the electrical box.	
1	<p>Release the lead wire of the fan motor from the ditch.</p>  <p>(R4042)</p>	
2	<p>Remove the 2 screws fixing the electrical box.</p>  <p>(R4043)</p>	
3	<p>Remove the screw of the terminal board cover.</p>  <p>(R4044)</p>	

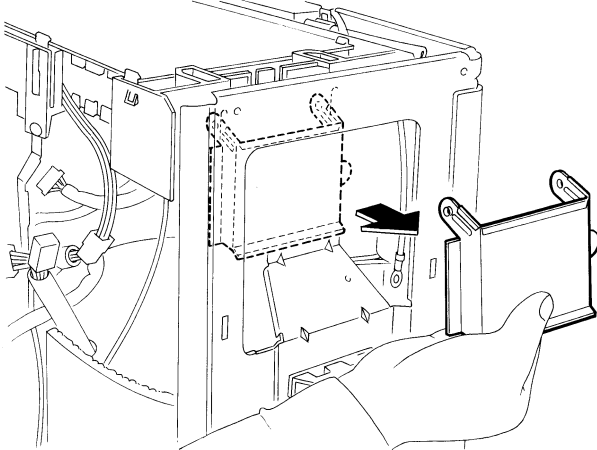
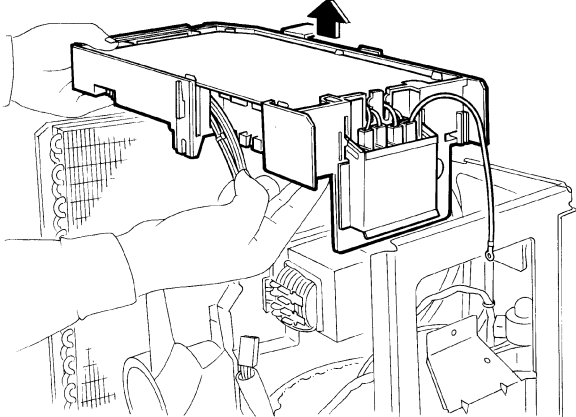
Step	Procedure	Points
4	<p data-bbox="201 215 443 275">Remove the terminal board cover.</p>  <p data-bbox="1059 719 1118 741">(R4045)</p>	
5	<p data-bbox="201 752 424 813">Lift and remove the electrical box.</p>  <p data-bbox="1011 1240 1070 1263">(R4046)</p>	

3.4 Removal of Propeller Fan and Fan Motor

Procedure



Warning Be sure to wait 10 minutes or more after turning off all power supplies before disassembling work.

Step	Procedure	Points
<ul style="list-style-type: none"> Remove the external panels and the drip proof plate protecting the electrical parts. 	<p style="text-align: right;">(R4047)</p>	<ul style="list-style-type: none"> Be sure to restore the drip proof plate and to avoid losing or damaging it.
<p>1 Remove the 2 screws of the fan motor assembly.</p>	<p style="text-align: right;">(R4048)</p>	
<p>2 Release the 2 hooks of the fan motor stand.</p>	<p style="text-align: right;">(R4049)</p>	

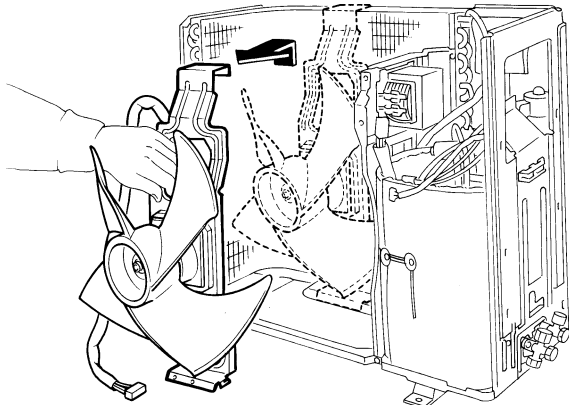
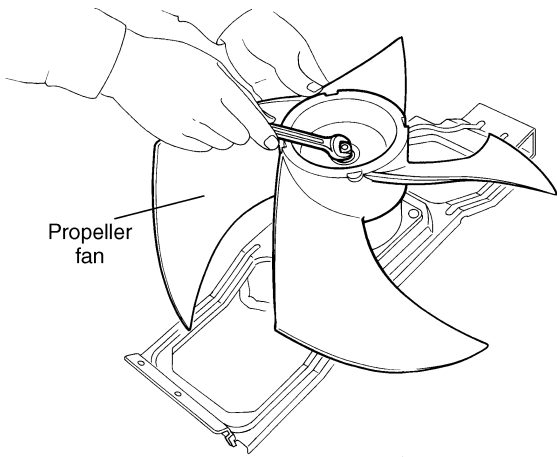
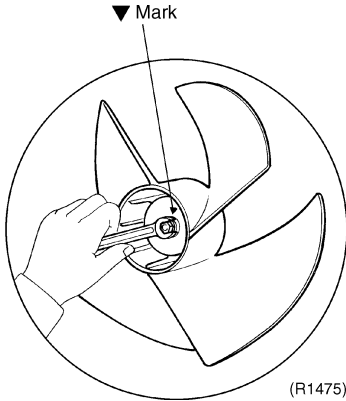
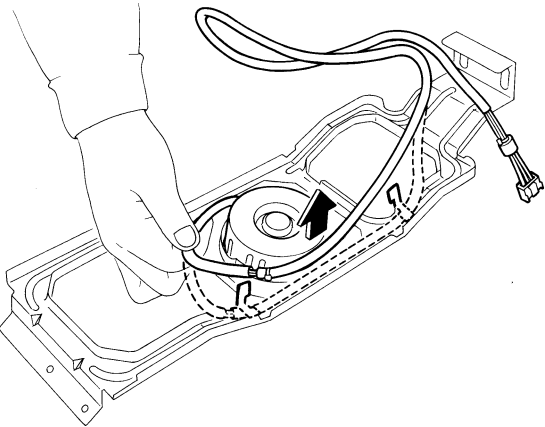
Step	Procedure	Procedure	Points
3	Remove the fan motor assembly.	 <p>(R4050)</p>	
4	The propeller fan can be removed when the washer faced nut (M8) is removed.	 <p>(R4051)</p>	 <p>(R1475)</p> <ul style="list-style-type: none"> ■ When restoring, match the ▼ mark of the propeller fan with the D-cut of the motor shaft. ■ The fan should be restored so that the mark ● will be at upper part of the fan motor.
5	Release the lead wire from the hooks.	 <p>(R4052)</p>	

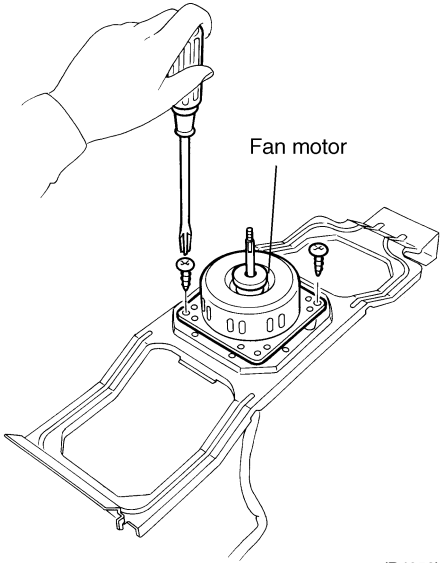
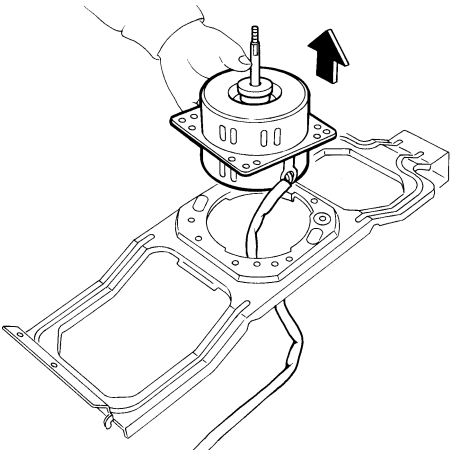
Step	Procedure	Points
6	<p>Remove the 2 screws for removing the fan motor.</p>  <p>(R4053)</p>	
7	<p>Remove the fan motor.</p>  <p>(R4054)</p>	

3.5 Removal of Partition Plate and Reactor

Procedure

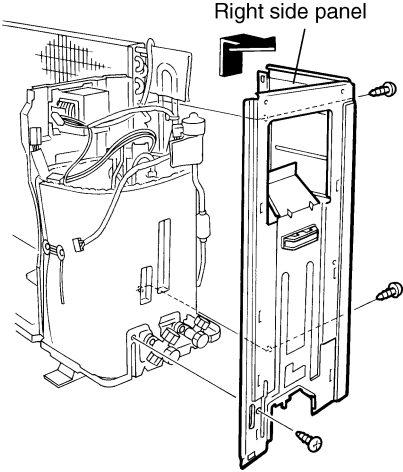
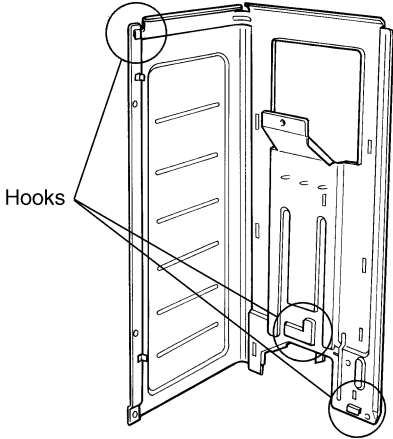
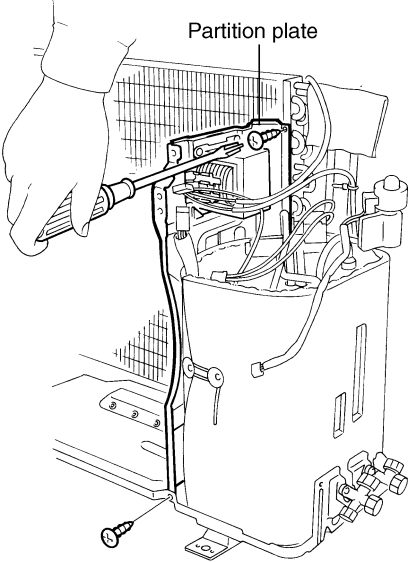

Warning Be sure to wait 10 minutes or more after turning off all power supplies before disassembling work.

Step	Procedure	Points
<p>1. Remove the right side panel.</p> <p>1 Remove the 3 screws for removing the right side panel.</p> <p>2 Lift the right side panel to disengage the hooks.</p>	 <p>Right side panel</p> <p>(R4055)</p>  <p>Hooks</p> <p>(R4056)</p>	<p>■ Insert the 3 hooks for the restoration.</p>
<p>2. Remove the partition plate.</p> <p>1 Remove the 2 screws fixing the partition plate.</p>	 <p>Partition plate</p> <p>(R4057)</p>	

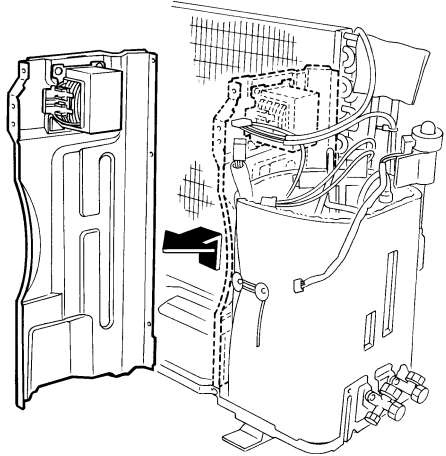
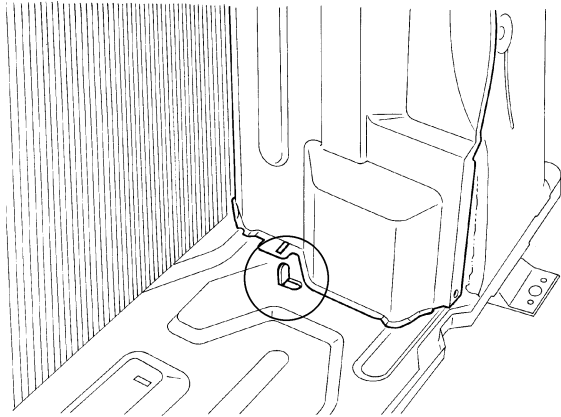
Step	Procedure	Procedure	Points
2	Pull the partition plate upward to remove.	 <p>(R4058)</p>	
3	When restoring the partition plate, fit the hook into the bottom frame.	 <p>(R4059)</p>	

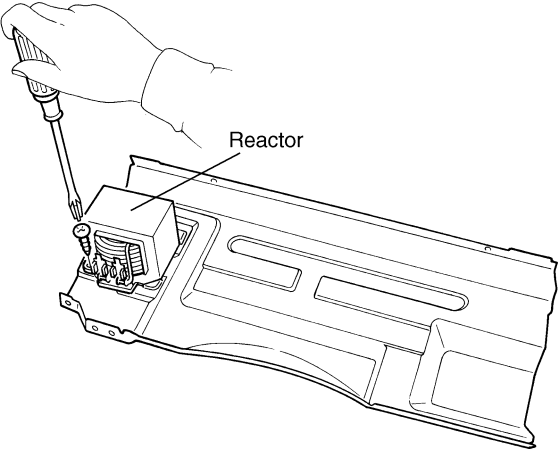
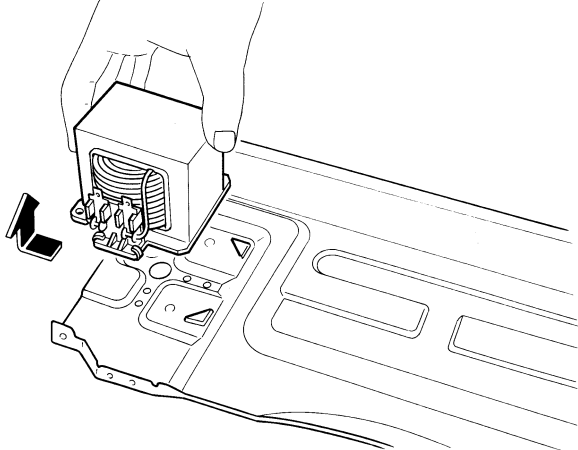
Step	Procedure	Points
<p>3. Remove the reactor.</p> <p>1</p>	<p>The reactor can be released by removing the screw.</p>  <p>(R4060)</p>  <p>(R4061)</p>	

3.6 Removal of Sound Insulation Pad

Procedure

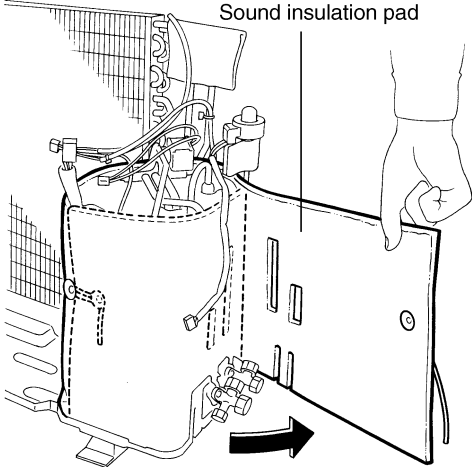
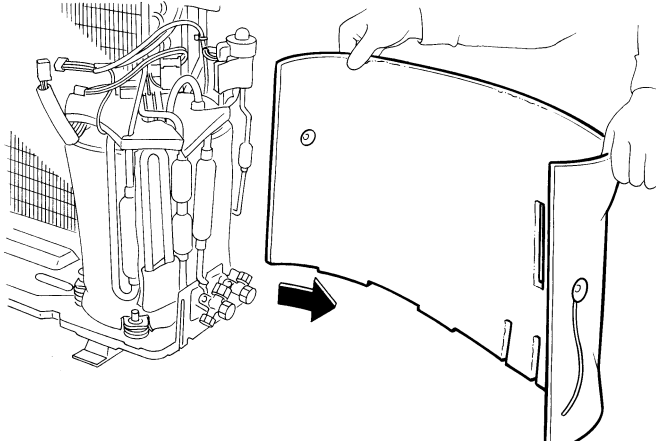

Warning Be sure to wait 10 minutes or more after turning off all power supplies before disassembling work.

Step	Procedure	Points
1. Remove the sound insulation pad.	<p data-bbox="199 434 464 528">1 Untie the string fixing the sound insulation pad to the compressor.</p>  <p data-bbox="1007 943 1066 958">(R4062)</p>	<ul style="list-style-type: none"> ■ Since the slit prepared for the piping connection on the sound insulation pad is torn easily, remove the pad carefully. ■ When restoring, the sound insulation pad should pass the internal side of the piping.
2 Pull out the sound insulation pad for the body.	<p data-bbox="199 981 443 1070">2 Pull out the sound insulation pad for the body.</p>  <p data-bbox="1203 1509 1262 1525">(R4063)</p>	

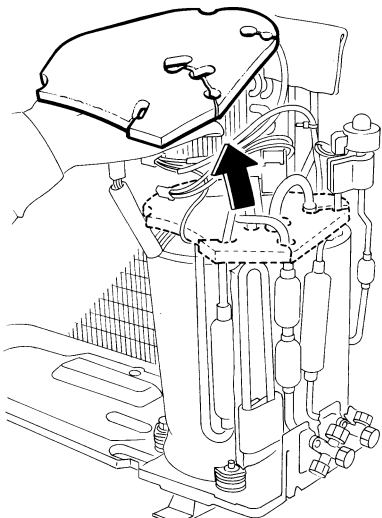
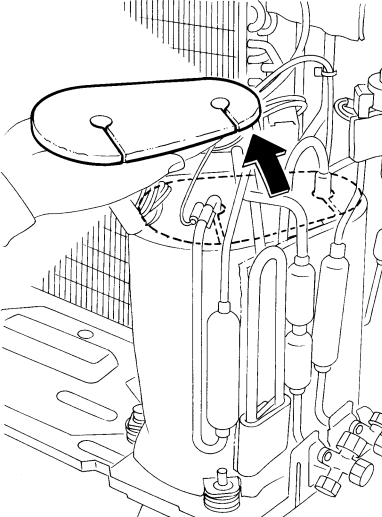
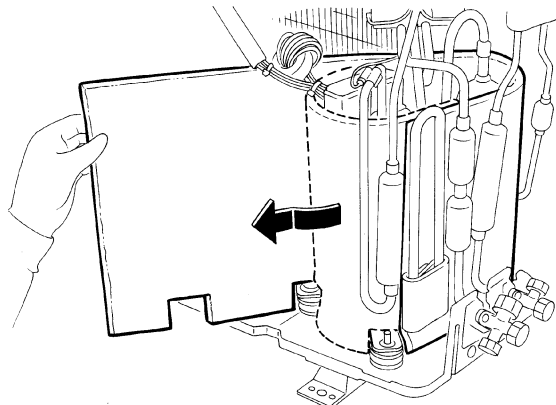
Step	Procedure	Procedure	Points
3	Pull out the top sound insulation pad.	 <p>(R4064)</p>	<ul style="list-style-type: none"> ■ Since the slit prepared for the piping on the sound insulation pad is torn easily, remove the pad carefully.
4	Pull out the under pad of the top sound insulation.	 <p>(R4065)</p>	
5	Pull out the inner sound insulation pad.	 <p>(R4066)</p>	<ul style="list-style-type: none"> ■ When restoring, the sound insulation pad should pass the internal side of the piping.

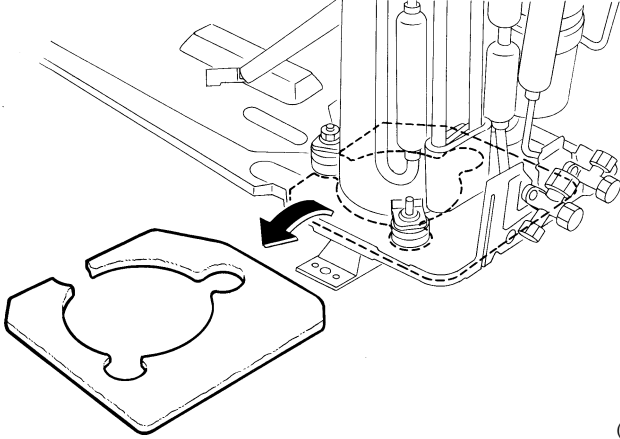
Step	Procedure	Points
6	<p data-bbox="204 215 448 275">Pull out the bottom sound insulation pad.</p>  <p data-bbox="1129 696 1193 712">(R4067)</p>	

3.7 Removal of Electronic Expansion Valve and Four Way Valve



Procedure

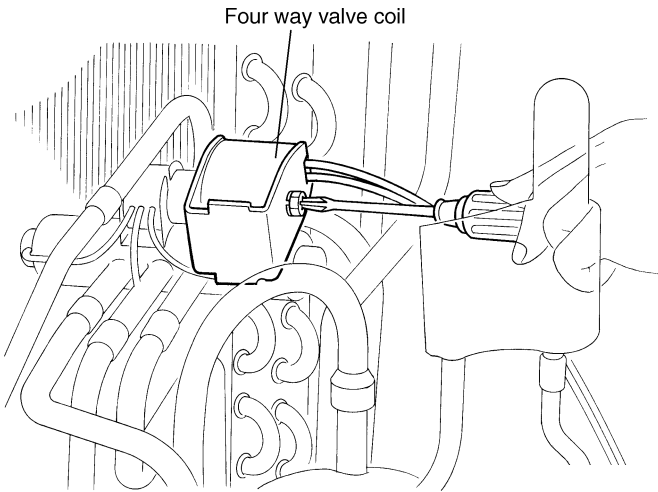
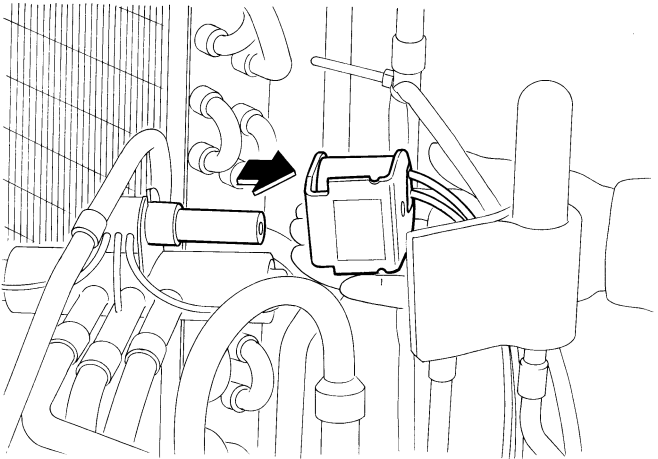

Warning Be sure to wait 10 minutes or more after turning off all power supplies before disassembling work.

Step	Procedure	Points
1. Remove the parts around the four way valve.	<p>Terminal cover</p>	
1 Remove the terminal cover and the lead wires of the compressor so as not to be burnt out by a gas brazing machine.		
2 Release the heat exchanger thermistor.	<p>Clip Heat exchanger thermistor</p>	<p>(R4068)</p> <ul style="list-style-type: none"> ■ The thermistor for the heat exchanger is fixed by a clamp material at one portion. Be sure to fix the thermistor back on the original position when restoring.
3 Remove the electric expansion valve coil.	<p>Electronic expansion valve coil</p>	<p>(R4069)</p> <ul style="list-style-type: none"> ■ Pay attention so as not to lose the clip for the thermistor. <p>Warning! Ventilate when the refrigerant leaks during the work. (If the refrigerant is exposed to the fire, it will cause toxic gas.)</p>
	<p>(R4070)</p>	

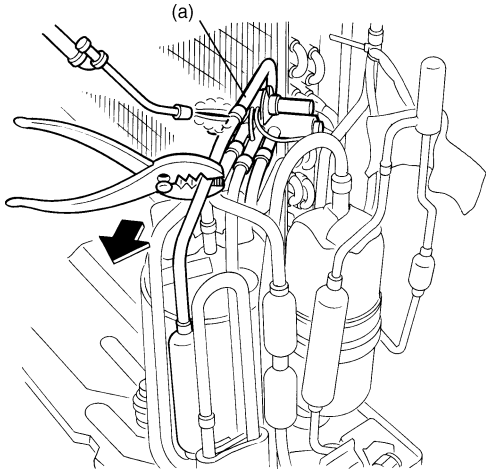
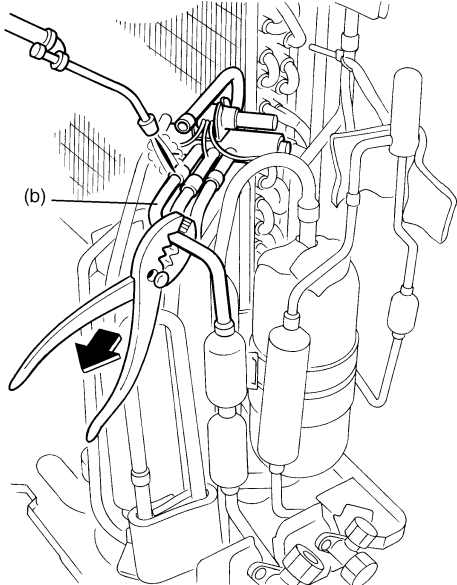
Step	Procedure	Points
4	<p data-bbox="201 215 456 309">Loosen the screw and remove the four way valve coil.</p> <div data-bbox="517 271 1177 761">  <p data-bbox="740 271 927 297">Four way valve coil</p> </div> <div data-bbox="1145 763 1209 790">(R4071)</div> <div data-bbox="517 842 1177 1299">  </div> <div data-bbox="1121 1312 1185 1339">(R4072)</div>	

Step	Procedure	Points
<p>■ Confirm that the refrigerant is completely empty in the refrigerant circuit before starting work.</p>	 <p>(R4073)</p>  <p>(R4074)</p>	<p>Caution  Be careful about four way valve, pipes and so on, which were heated up by a gas brazing machine, so as not to get burnt on your hands.</p> <p>Cautions at the restoration.</p> <ol style="list-style-type: none"> 1. Restore the piping by non-oxidation brazing. Braze it quickly unless nitrogen gas can be used. 2. It is required to prevent the carbonization of the oil inside the four way valve and the deterioration of the gaskets affected by heat. For the sake of this, wrap the four way valve with wet cloth and make up water so that the cloth will not be dried and avoid excessive heating. (It keeps below 120°C). <p>■ Be careful so as not to break pipes by pressing the pipes excessively by pliers when withdrawing the piping.</p>

Step	Procedure	Points
	<div data-bbox="560 309 1007 763"> <p>(c)</p> </div> <div data-bbox="951 779 1011 801">(R4075)</div> <div data-bbox="560 875 1007 1330"> <p>(d)</p> </div> <div data-bbox="963 1350 1024 1373">(R4076)</div>	<p>In case that the removal seems to be hard;</p> <ol style="list-style-type: none"> 1. Remove the piping connection part (brazing part) which is easy to remove and restore. 2. Cut the pipes on the main unit by a miniature copper tube cutter in order to make it easy to remove. <p>NOTE: Don't use a metal saw for cutting pipes by all means because the chips come into the circuit.</p> <p>Cautions at the restoration. Wrap the motor valve with wet cloth and make up water so that the cloth will not be dried and avoid excessive heating.</p> <p> Caution Be careful about four way valve, pipes and so on, which were heated up by a gas brazing machine, so as not to get burnt on your hands.</p>

3.8 Removal of Compressor

Procedure

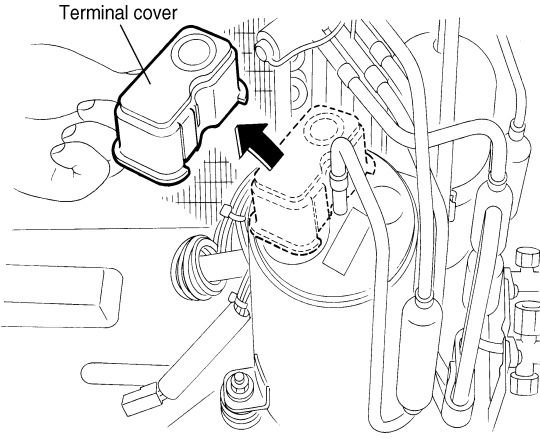
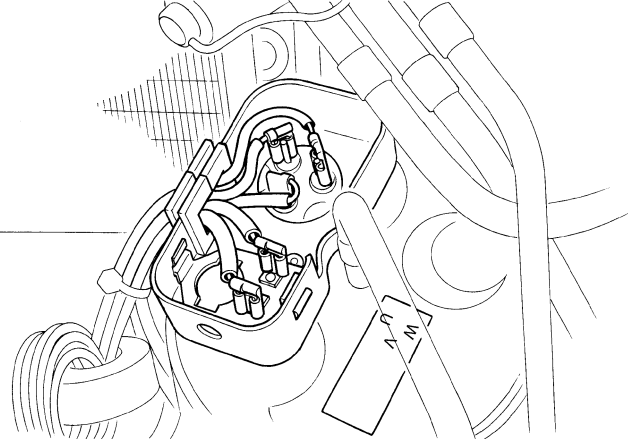
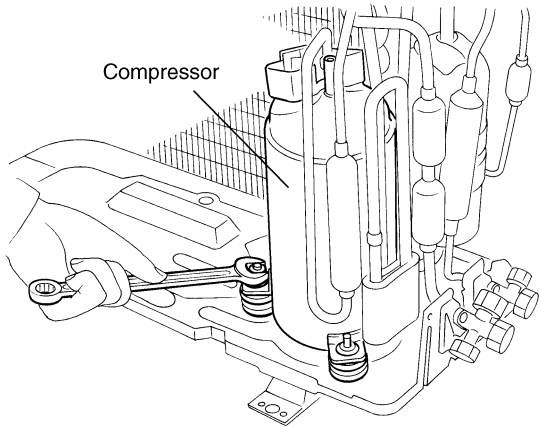

Warning Be sure to wait 10 minutes or more after turning off all power supplies before disassembling work.

Step	Procedure	Points
<p>1. Remove the parts around the compressor.</p> <p>1 Remove the terminal cover and the lead wires of the compressor so as not to be burnt out by a gas brazing machine.</p>	 <p>(R4077)</p>  <p>(R4078)</p>	<ul style="list-style-type: none"> ■ Be careful so as not to burn the compressor terminals or the name plate.
<p>2. Remove the compressor.</p> <p>1 The mounting nut for the compressor is only one piece.</p> <p>2 Remove the nut by an open-end wrench.</p>	 <p>(R4079)</p>	<ul style="list-style-type: none"> ■ Remove the four way valve and the electronic expansion valve also so as not to be burnt out.

Part 8 Others

1. Others	204
1.1 Test Run from the Remote Controller	204
1.2 Jumper Settings	205

1. Others

1.1 Test Run from the Remote Controller

For Heat pump

In cooling mode, select the lowest programmable temperature; in heating mode, select the highest programmable temperature.

- Trial operation may be disabled in either mode depending on the room temperature.
- After trial operation is complete, set the temperature to a normal level.
(26°C to 28°C in cooling mode, 20°C to 24°C in heating mode)
- For protection, the system disables restart operation for 3 minutes after it is turned off.

For Cooling Only

Select the lowest programmable temperature.

- Trial operation in cooling mode may be disabled depending on the room temperature.
Use the remote control for trial operation as described below.
- After trial operation is complete, set the temperature to a normal level (26°C to 28°C).
- For protection, the machine disables restart operation for 3 minutes after it is turned off.

Trial Operation and Testing

1. Measure the supply voltage and make sure that it falls in the specified range.
 2. Trial operation should be carried out in either cooling or heating mode.
 3. Carry out the test operation in accordance with the Operation Manual to ensure that all functions and parts, such as louver movement, are working properly.
- The air conditioner requires a small amount of power in its standby mode. If the system is not to be used for some time after installation, shut off the circuit breaker to eliminate unnecessary power consumption.
 - If the circuit breaker trips to shut off the power to the air conditioner, the system will restore the original operation mode when the circuit breaker is opened again.

Trial operation from Remote Controller

- (1) Press ON/OFF button to turn on the system.
- (2) Simultaneously press center of TEMP button and MODE buttons.
- (3) Press MODE button twice.
(“T” will appear on the display to indicate that Trial Operation mode is selected.)
- (4) Trial run mode terminates in approx. 15 minutes and switches into normal mode. To quit a trial operation, press ON/OFF button.

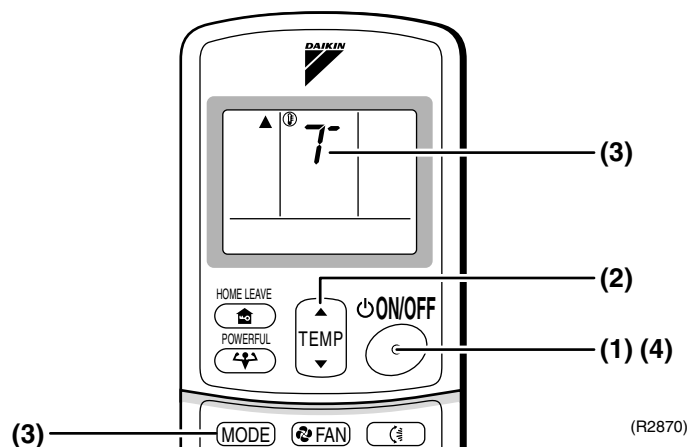

1.2 Jumper Settings

1.2.1 When Two Units are Installed in One Room

When two indoor units are installed in one room, the two wireless remote controllers can be set for different addresses.

How to set the different addresses

- Control PCB of the indoor unit
 - (1) Remove the front grille. (3 screws)
 - (2) Remove the electrical box (1-screw).
 - (3) Remove the drip proof plate. (4 tabs)
 - (4) Cut the address jumper **JA** on the control PCB.

- Wireless remote controller
 - (1) Slide the front cover and take it off.
 - (2) Cut the address jumper **J4**.

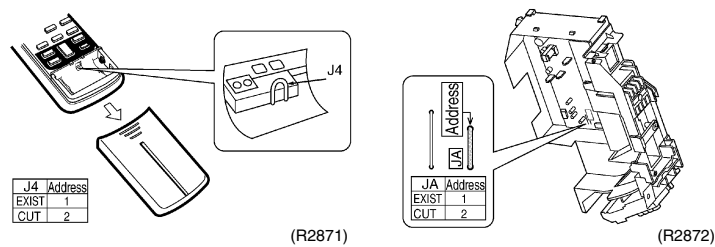

1.2.2 Jumper Setting

Jumper (On indoor control PCB)	Function	When connected (factory set)	When cut
JC	Power failure recovery function	Auto-restart	Unit does not resume operation after recovering from a power failure. Timer ON-OFF settings are cleared.
JB	Fan speed setting when compressor is OFF on thermostat.	Fan speed setting ; Remote controller setting	Fan rpm is set to "0" <Fan stop>

Part 9

Appendix

1. Piping Diagrams.....	208
1.1 Indoor Units.....	208
1.2 Outdoor Units.....	209
2. Wiring Diagrams.....	213
2.1 Indoor Units.....	213
2.2 Outdoor Units.....	214

1. Piping Diagrams

1.1 Indoor Units

FTK(X)S 20/25/35 CVMB(9)(8), ATK(X)S 20/25/35 CVMB(9)
FTN20/25/35CVMB9, FTYN20/25/35CVMB9

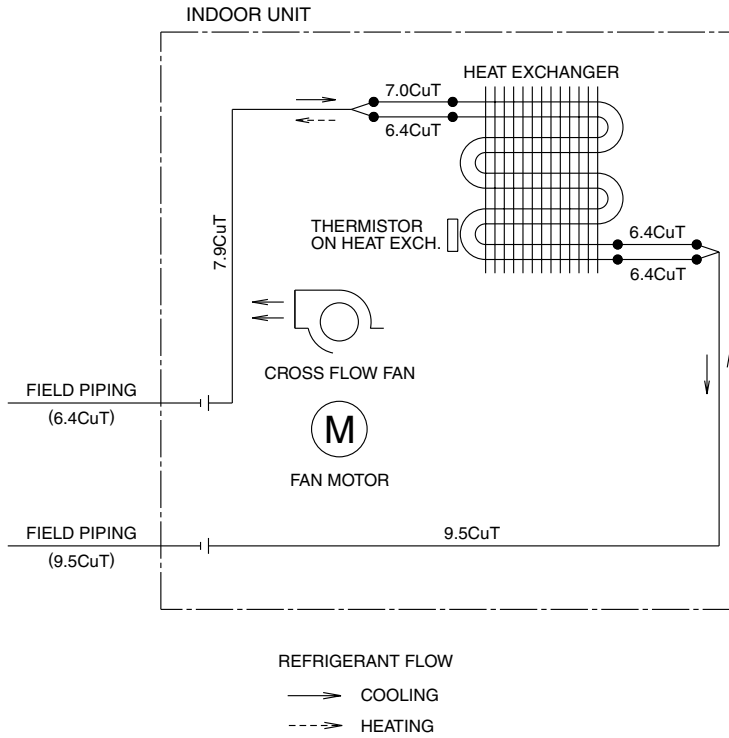

C:4D033698B

1.2 Outdoor Units

1.2.1 Cooling Only

RKS20/25CVMB, ARKS20/25CVMB

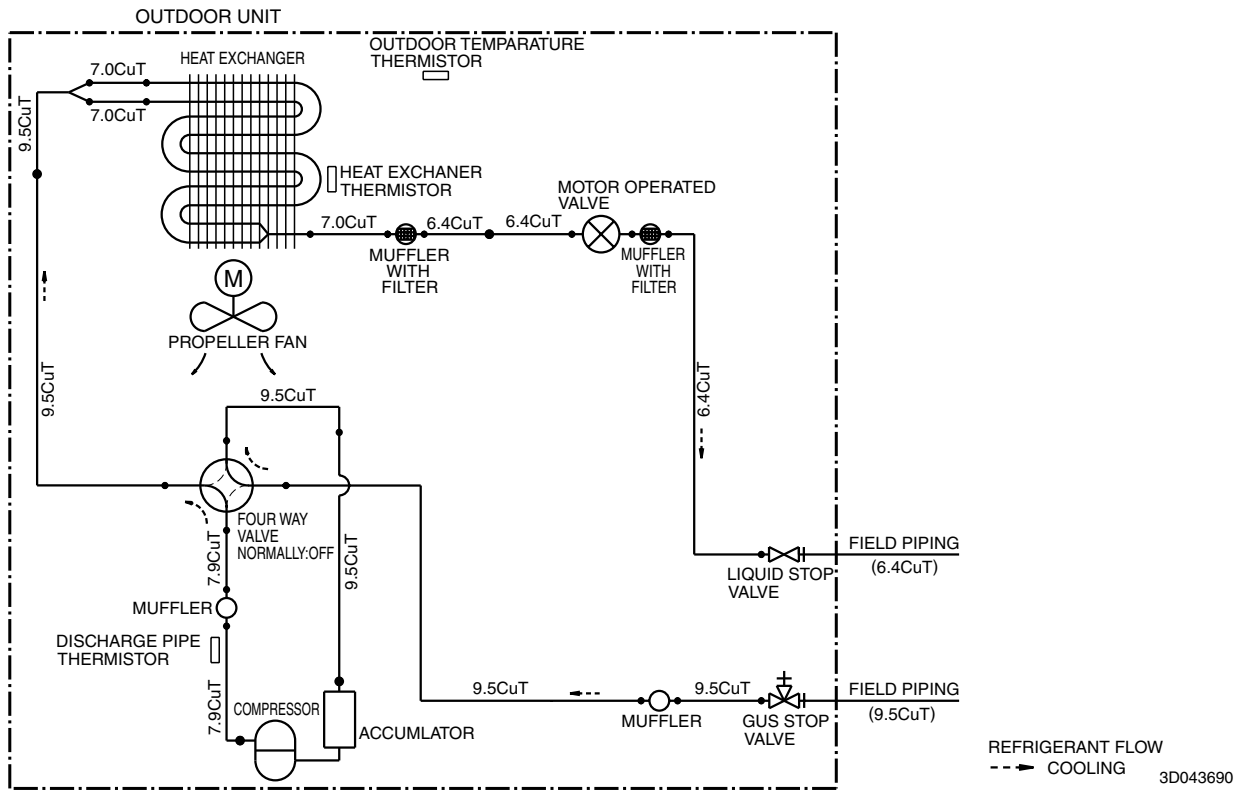

RKS35CVMB, ARKS35CVMB

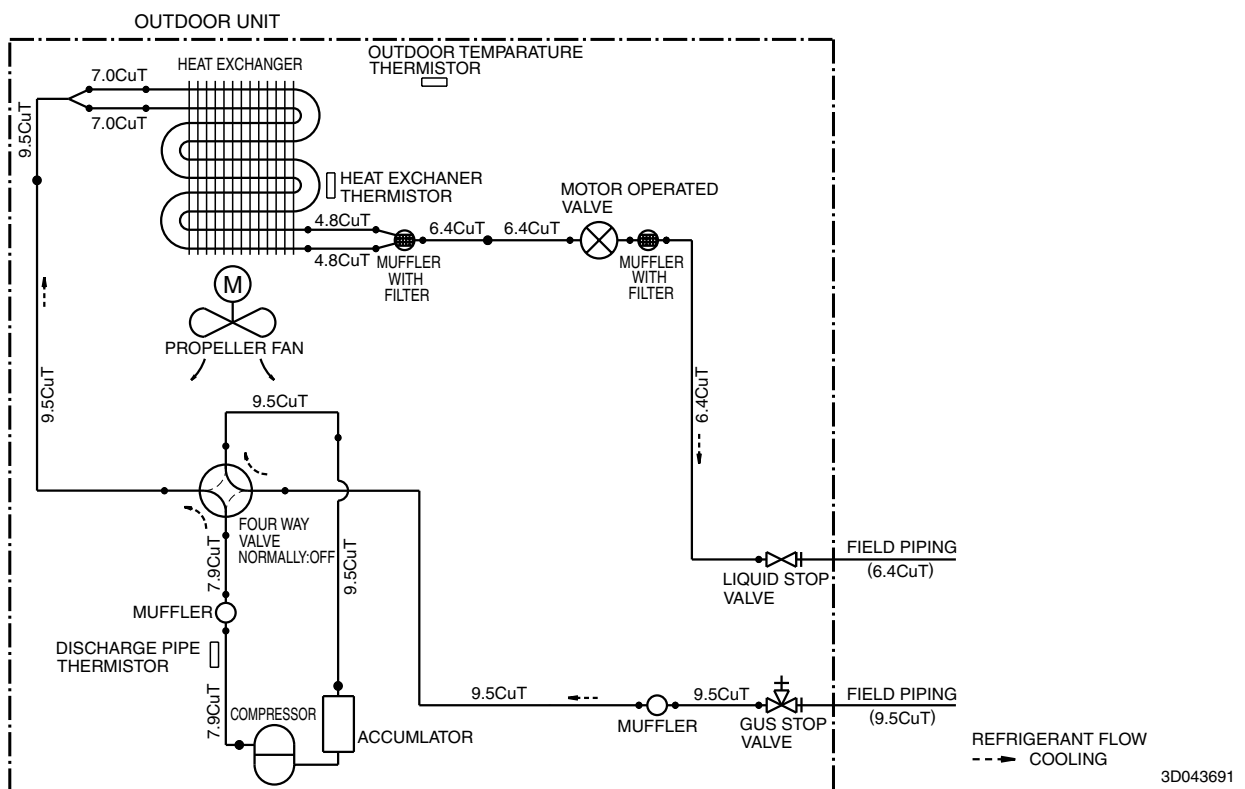

RKH20/25CVMB9, ARKH20/25CVMB9, RN20/25CVMB9

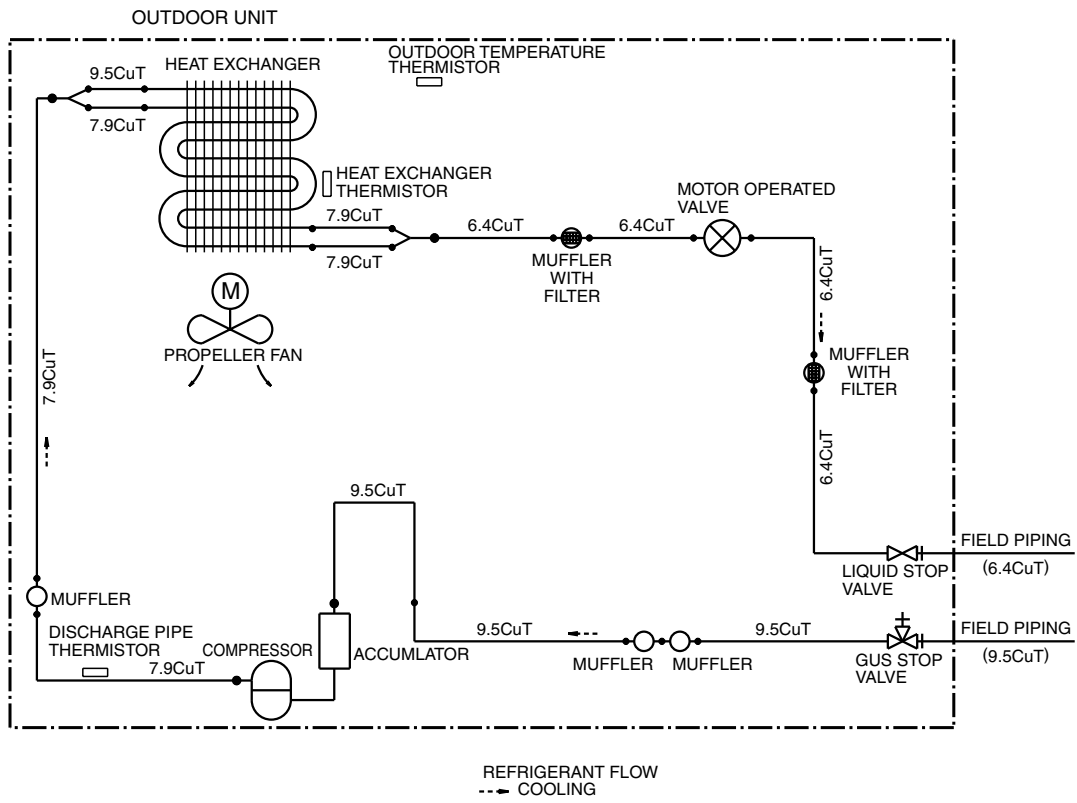

RKH35CVMB9, ARKH35CVMB9, RN35CVMB9

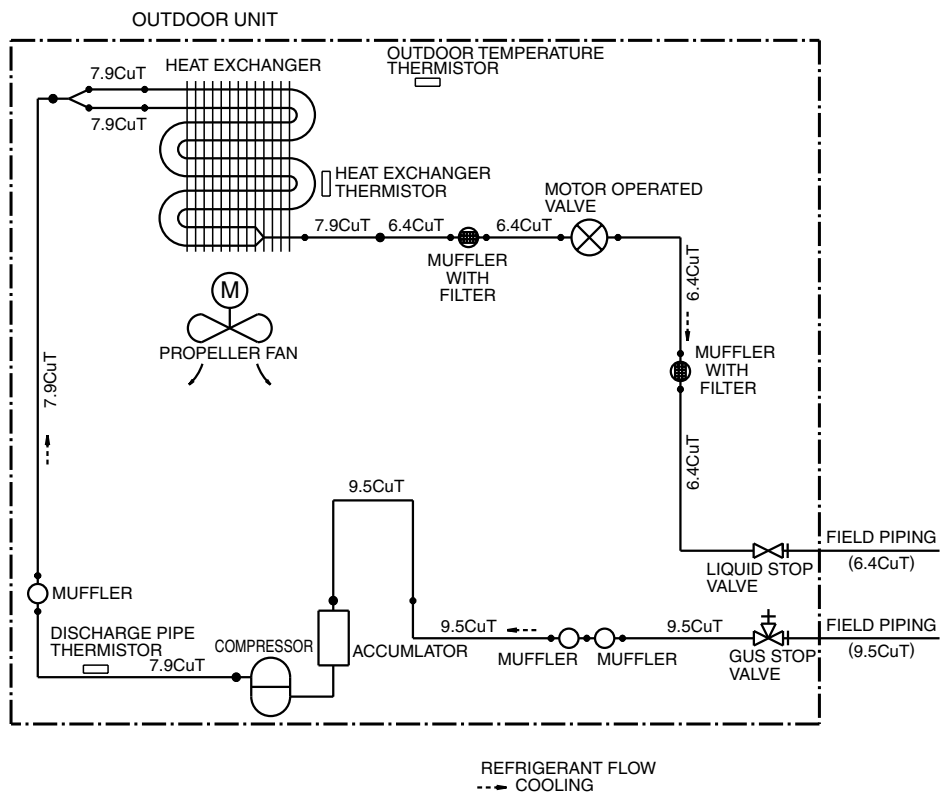

1.2.2 Heat Pump

RXS20/25CVMB, ARXS20/25CVMB

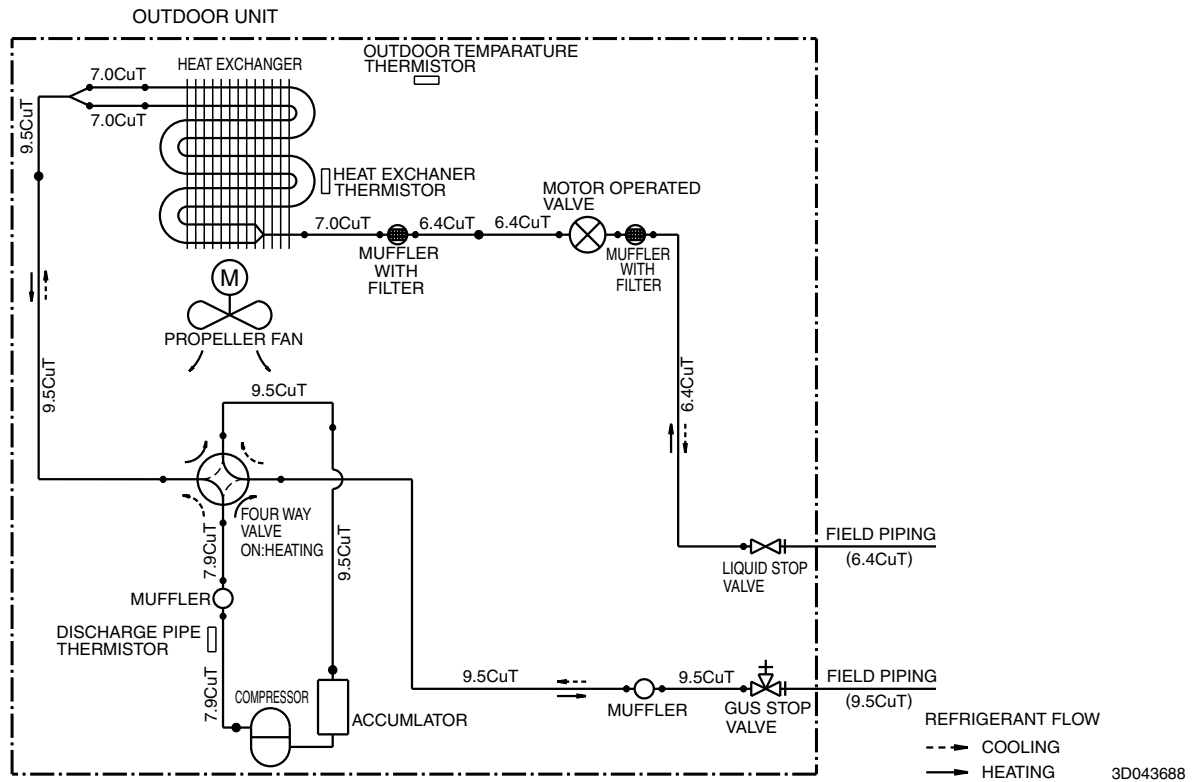

RXS35CVMB, ARXS35CVMB

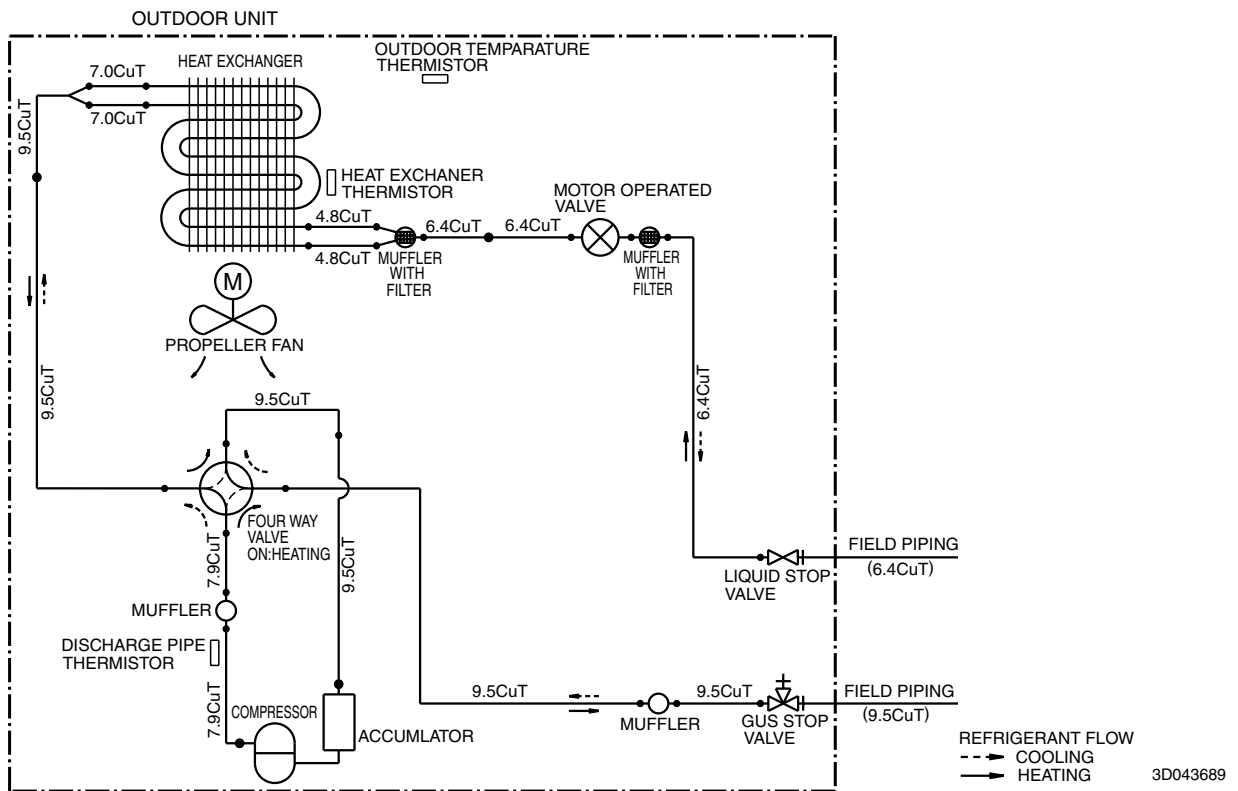

RXH20/25CVMB9, ARXH20/25CVMB9, RYN20/25CVMB9

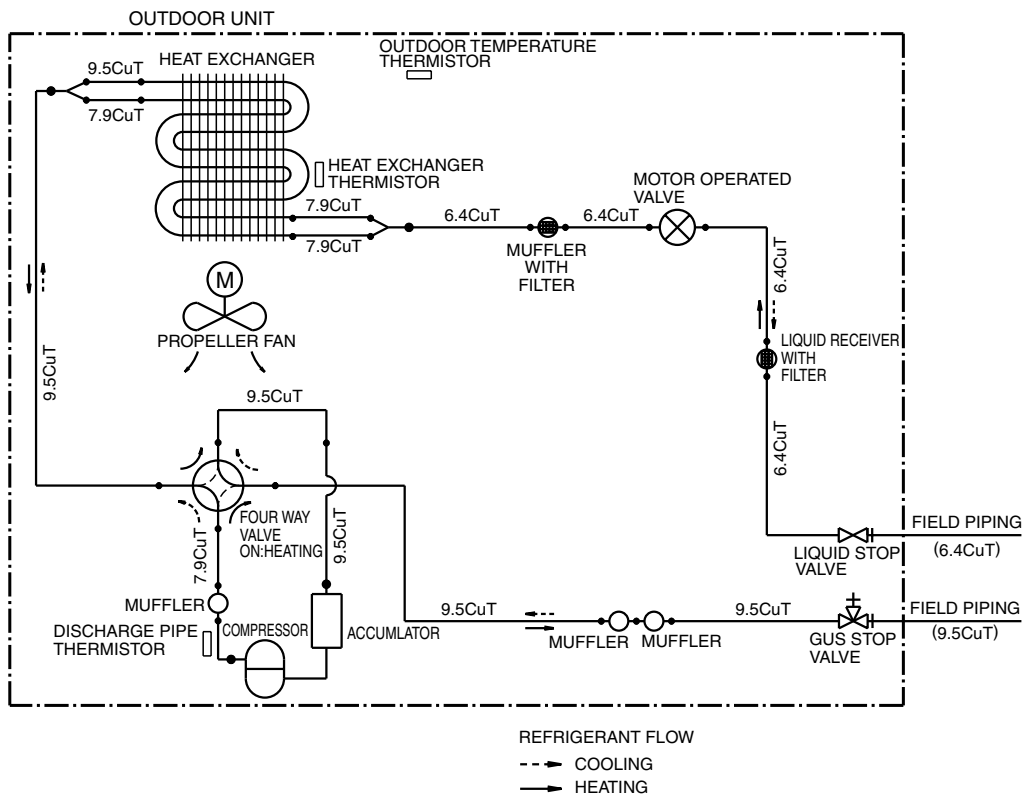

RXH35CVMB9, ARXH35CVMB9, RYN35CVMB9

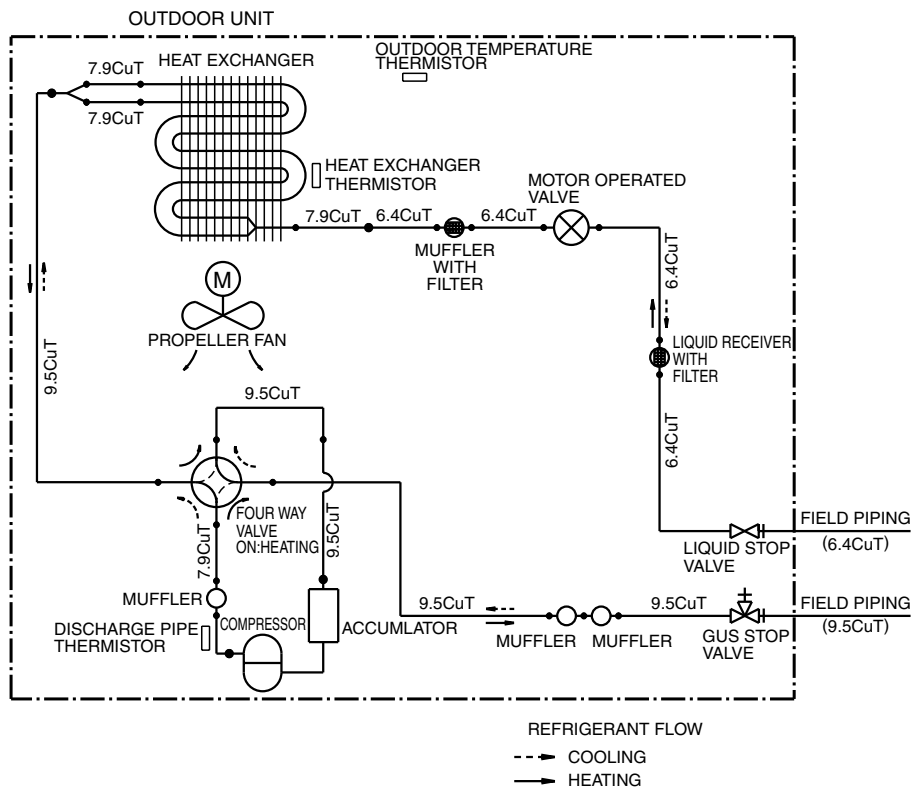

2. Wiring Diagrams

2.1 Indoor Units

FTK(X)S 20/25/35 CVMB(9)(8), ATK(X)S 20/25/35 CVMB(9)

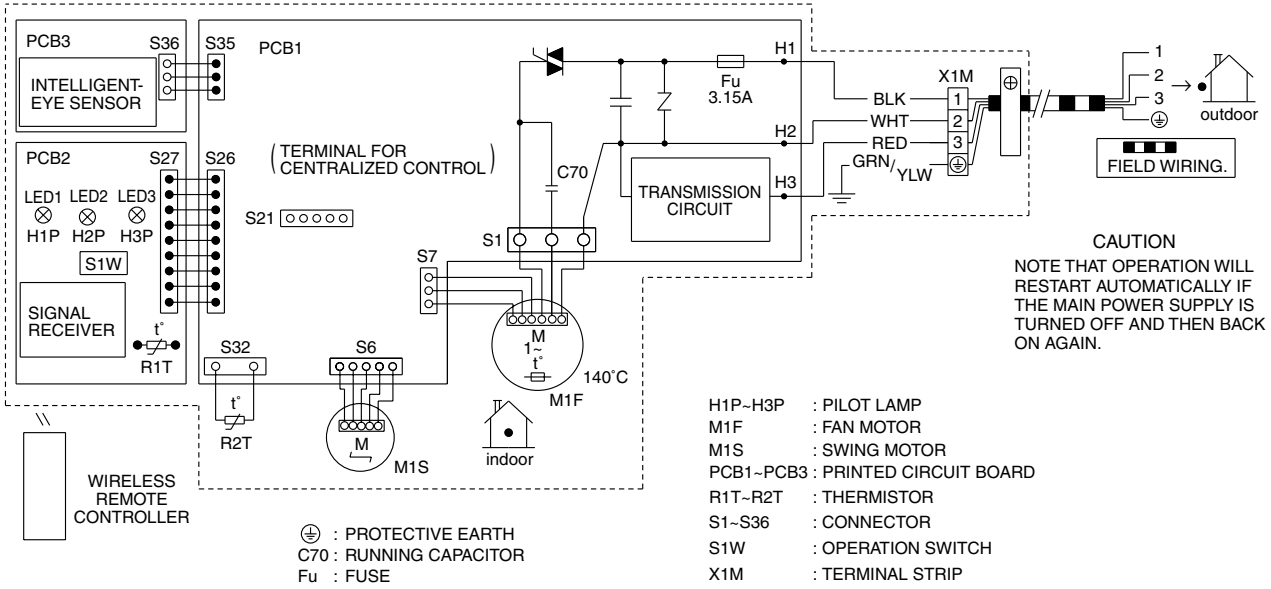

C:3D033599C

FTN20/25/35CVMB9, FTYN20/25/35CVMB9

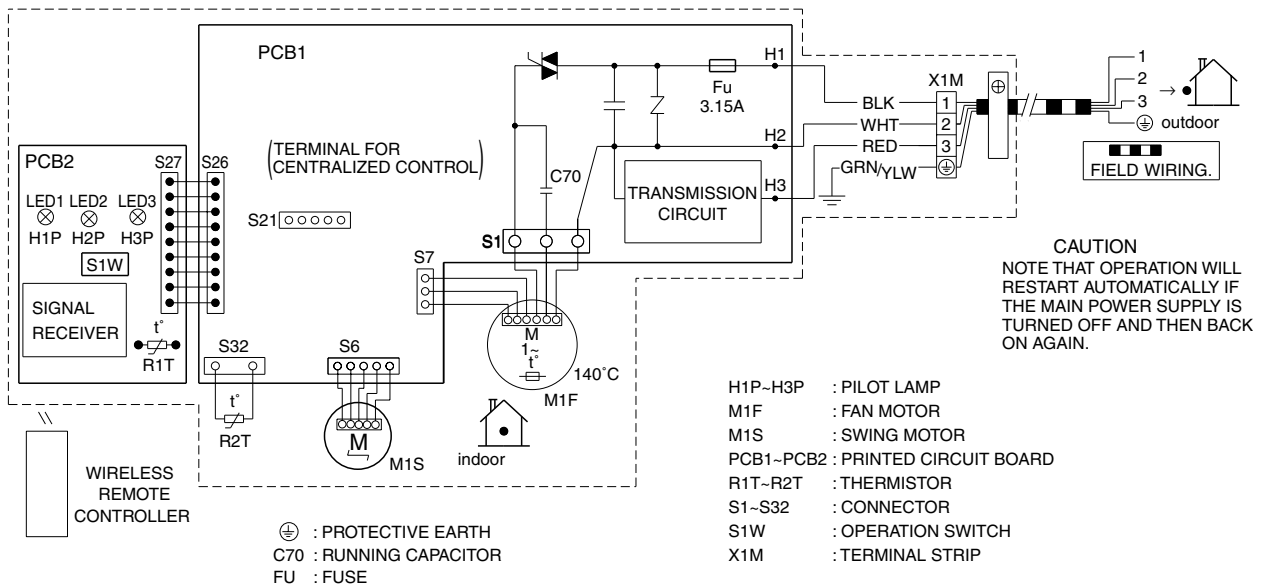

C:3D038710A

2.2 Outdoor Units

RK(X)S 20/25/35 CVMB, ARK(X)S 20/25/35 CVMB

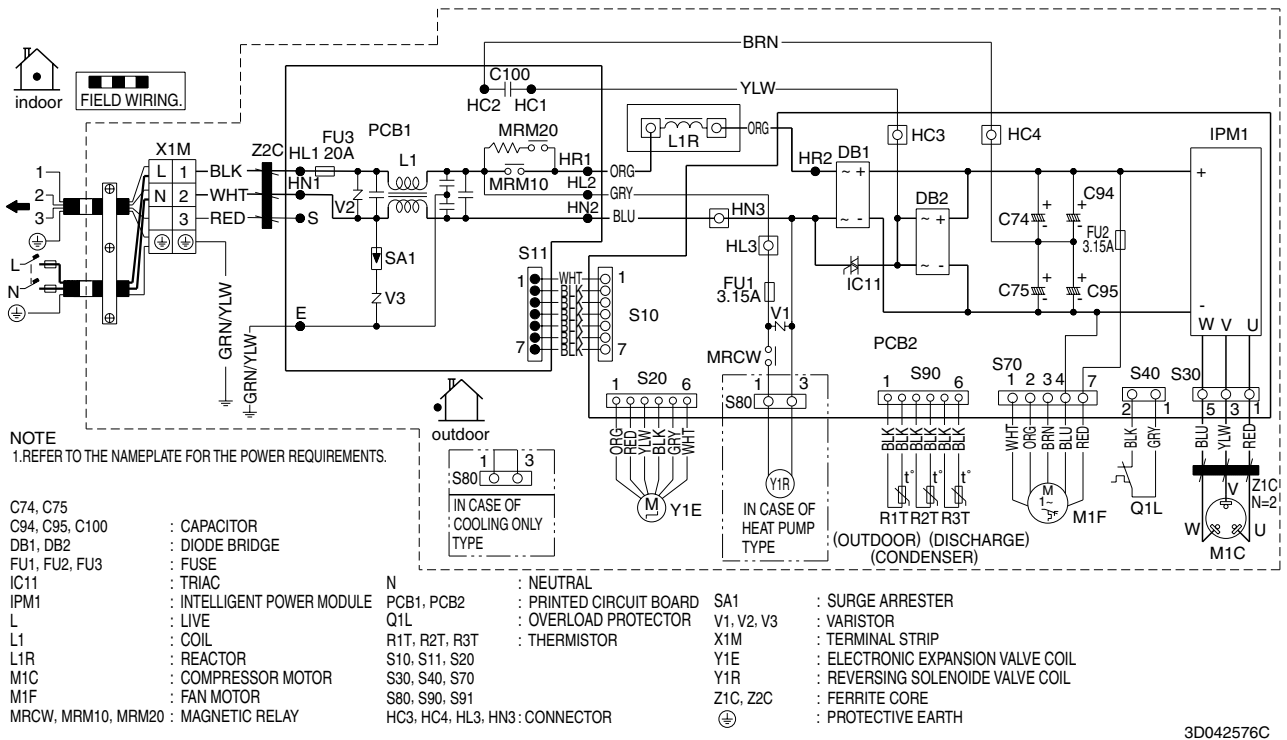

RKH20/25/35CVMB9, ARKH20/25/35CVMB9, RN20/25/35CVMB9

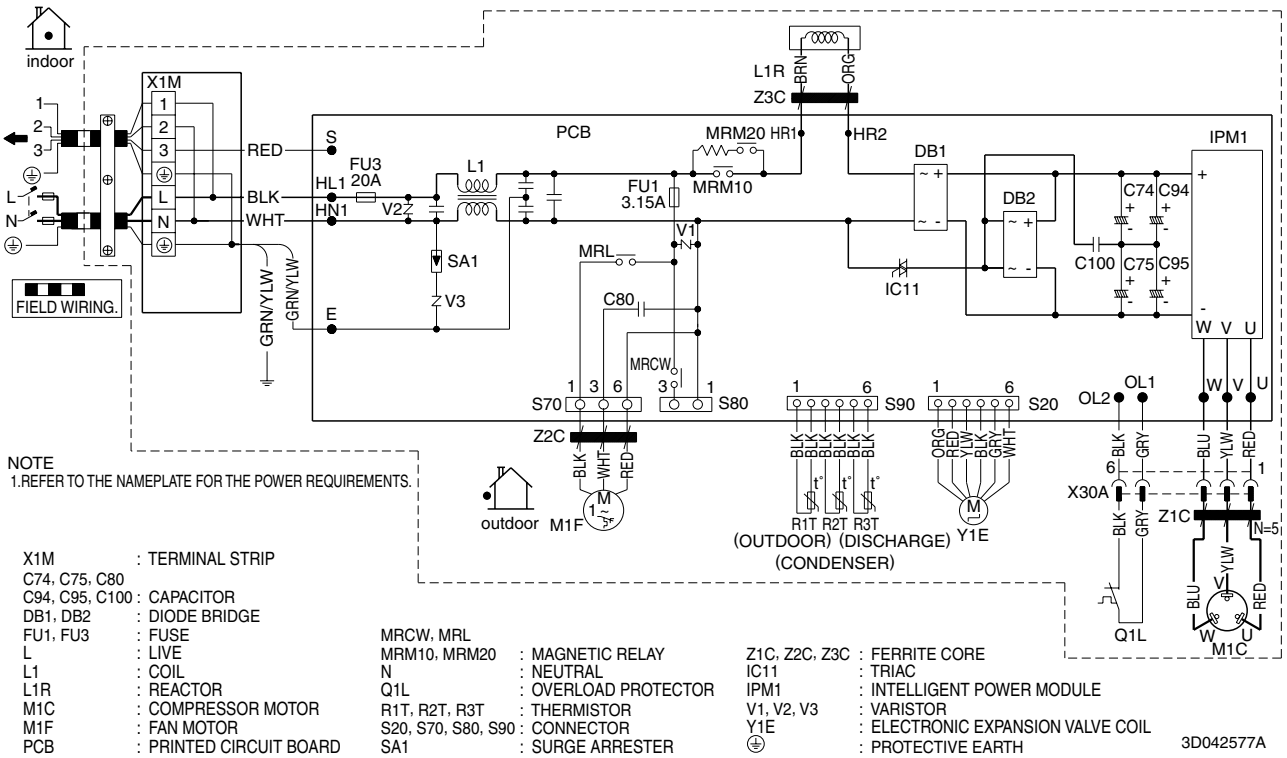

RXH20/25/35CVMB9, ARXH20/25/35CVMB9, RYN20/25/35CVMB9

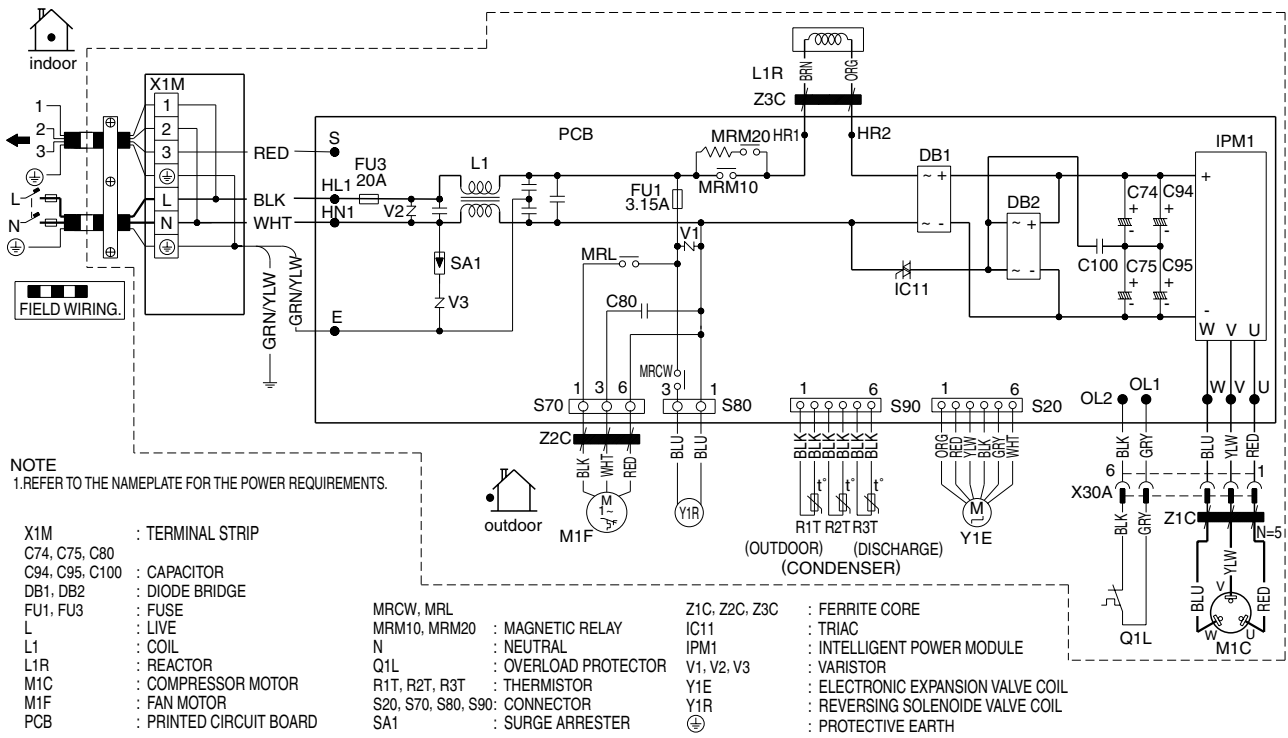

3D042575A

Index

Numerics

00	95
3-minutes standby	41, 48

A

A1	96
A5	97
A6	99
address setting jumper	24
air filter	41, 134
air flow control	33
air flow direction	71
air purifying filter with photocatalytic deodorizing function	41
ARC433A	92
AUTO · DRY · COOL · HEAT · FAN operation	69
automatic operation	35
auto-restart	24, 205
auto-restart function	41
auto-swing	32
auxiliary pipe	149

B

bell mouth	159, 179
------------------	----------

C

C4	100
C9	100
care and cleaning	81
centralized control	24
check	
discharge pressure check	127
electronic expansion valve check	124
four way valve performance check	125
Hall IC check	131
installation condition check	127
inverter units refrigerant system check	129
outdoor unit fan system check	128
power supply waveforms check	129
power transistor check	130
thermistor resistance check	126
turning speed pulse input on the outdoor unit PCB check	130
compressor	171, 200
compressor lock	103
compressor overload	102
compressor protection function	48
connectors	24, 26, 28
connectors	
discharge pipe thermistor	182
electronic expansion valve	182
fan motor	142, 157, 181
four way valve	163, 181
outdoor air thermistor	182
outdoor heat exchanger thermistor	182

swing motor	142
control PCB (indoor unit)	25, 147
control PCB (outdoor unit)	27, 28, 173, 184
cover	
service cover	137
stop valve cover	156, 176
terminal board cover	185
terminal cover	169, 196, 200

D

DC fan lock	104
DC voltage / current sensor abnormality	112
defrost control	51
diagnosis mode	93
discharge pipe	53
discharge pipe control	48
discharge pipe temperature control	54, 108
discharge pipe thermistor	42, 43, 53, 114, 164
discharge pipe thermistor, connector	182
discharge pressure check	127
drain hose	148, 151
drain plug	151
drip proof plate	157, 180

E

E5	102
E6	103
E7	104
E8	105
EA	106
electric expansion valve	196
electrical box	142, 163, 185
electrical box temperature rise	115
electronic expansion valve check	124
electronic expansion valve control	52
electronic expansion valve, connector	182
error codes	
00	95
A1	96
A5	97
A6	99
C4	100
C9	100
E5	102
E6	103
E7	104
E8	105
EA	106
F3	108
F6	109
H6	111
H8	112
H9	113
J3	113
J6	113

L3	115
L4	117
L5	119
P4	113
U0	121
U2	123
U4	101
error codes and description	95
F	
F3	108
F6	109
facility setting jumper	26, 57
fan control	50
fan motor	152, 160, 187
fan motor fixing frame	160
fan motor or related abnormality	99
fan motor, connector	142, 157, 181
fan rotor	152
fan speed control	33
fan speed setting	24, 205
filter	
air filter	41, 134
air purifying filter with photocatalytic deodorizing function	41
filter PCB	27
forced cooling operation	31
forced operation mode	56
forced operation ON/OFF switch	24
four way valve	169, 196
four way valve abnormality	106
four way valve operation compensation	47
four way valve performance check	125
four way valve switching	47
four way valve, connector	163, 181
freeze-up protection control	49, 97
frequency control	30, 45
frequency principle	30
front grille	137
front panel	135, 157, 177
FU1	24, 26, 28
FU2	26
FU3	26, 28
functions, list	2
fuse	24, 26, 28
H	
H6	111
H8	112
H9	113
HA	24
Hall IC	33, 99
Hall IC check	131
HC3	26
HC4	26
heat exchanger	148
heat exchanger thermistor	42, 43, 100, 114, 142, 164, 196
heat exchanger thermistor,connector	182
heating peak-cut control	50
high pressure control	97
high pressure control in cooling	109
HL3	26
HN3	26
HOME LEAVE operation	39, 75
horizontal blade	140
hot start function	41
I	
indoor unit PCB abnormality	96
input current control	49
input over current detection	105
installation condition check	127
instruction	61
insufficient gas	121
insufficient gas control	55
insulation sheet	180
INTELLIGENT EYE	37
INTELLIGENT EYE operation	77
INTELLIGENT EYE sensor PCB	25
inverter powerful operation	40
inverter principle	30
inverter units refrigerant system check	129
J	
J3	113
J4	205
J6	113
J8	26
JA	24, 205
JB	24, 205
JC	24, 205
jumper settings	205
L	
L3	115
L4	117
L5	119
LED1	24
LED2	24
LED3	24
LEDA	26, 28
left side panel	178
left side plate	154
liquid compression protection function 2	50
lower limit for cooling	57
M	
mode changing control	47
mode hierarchy	44
mold proof air filter	41
motor	
fan motor	152, 160, 187
swing motor	147
N	
names of parts	63
NIGHT SET mode	36
O	
OL activation	102
ON/OFF button on indoor unit	41

operation lamp	90
outdoor air temperature thermistor	114
outdoor air thermistor, connector	182
outdoor unit fan system check	128
OUTDOOR UNIT SILENT operation	74
output over current detection	119
over current	55, 105, 119
overload	55, 102
overload protector	26
over-voltage detection	123
P	
P4	113
panel	
front panel	135, 157, 177
left side panel	178
right side panel	161, 190
top panel	157, 177
partition plate	165, 190
PI control	46
pipng diagrams	208
plate	
drip proof plate	157, 180
left side plate	154
partition plate	165, 190
right side plate	152
shelter	145, 156
position sensor abnormality	111
power failure recovery function	24, 205
power supply waveforms check	129
power transistor check	130
power-airflow dual flaps	32
POWERFUL operation	40, 73
POWERFUL operation mode	56
preheating operation	47
preparation before operation	66
printed circuit board (PCB)	
control PCB (indoor unit)	25, 147
control PCB (outdoor unit)	27, 28, 173, 184
filter PCB	27
INTELLIGENT EYE sensor PCB	25
signal receiver PCB	25, 146
problem symptoms and measures	91
programme dry function	34
propeller fan	158, 187
R	
radiation fin temperature rise	117
radiation fin thermistor	114
reactor	165, 192
reactor harnesses	163, 183
remote controller	92
right side panel	161, 190
right side plate	152
room temperature thermistor	100
RTH1	24
S	
S1	24, 142
S10	26
S11	26
S20	26, 28, 182
S21	24
S26	24
S27	24
S30	26
S32	24
S35	24
S36	24
S40	26
S6	24, 142
S7	24, 142
S70	26, 28, 157, 181
S80	26, 28, 163, 181
S90	26, 28, 182
safety precautions	61
self-diagnosis digital display	41
sensor malfunction detection	55
service check function	92
service cover	137
shelter	145, 156
signal receiver PCB	25, 146
signal receiving sign	41
signal transmission error	101
sound blanket	167
sound insulation pad	193
specifications	8
starting control	47
stop valve cover	156, 176
SW7	24
swing motor	147
swing motor, connector	142
T	
terminal board	143, 173
terminal board cover	185
terminal cover	169, 196, 200
test run	204
thermistor	
discharge pipe thermistor	42, 43, 53, 114, 164
indoor heat exchanger thermistor	
	42, 43, 100, 142
outdoor air temperature thermistor	114
outdoor heat exchanger thermistor	
	42, 43, 114, 164, 196
radiation fin thermistor	114
room temperature thermistor	100
thermistor or related abnormality (indoor unit)	100
thermistor or related abnormality (outdoor unit)	113
thermistor resistance check	126
TIMER operation	79
top panel	157, 177
troubleshooting	84, 95
troubleshooting with LED indication	90
turning speed pulse input on the outdoor unit PCB	
check	130
U	
U0	121
U2	123
U4	101

V

V1	24, 26, 28
V2	26, 28
V3	26, 28
varistor	24, 26, 28
vertical blade	141
voltage detection function	56

W

wide-angle louvres	32
wiring diagrams	213

remote controller92

S

service check function92

signal receiver PCB25

signal transmission error (between indoor and outdoor units)101

T

target discharge pipe temperature control54

thermistor or related abnormality (indoor unit)100

thermistor or related abnormality (outdoor unit) ...113

thermistor resistance check126

trial operation from remote controller204

turning speed pulse input on the outdoor unit PCB check130

W

wiring diagrams

ARK(X)S 20/25/35 CVMB214

ARKH20/25/35CVMB9214

ARXH20/25/35CVMB9215

ATK(X)S 20/25/35 CVMB(9)213

FTK(X)S 20/25/35 CVMB(9)(8)213

FTN20/25/35CVMB9213

FTYN20/25/35CVMB9213

RK(X)S 20/25/35 CVMB214

RKH20/25/35CVMB9214

RN20/25/35CVMB9214

RXH20/25/35CVMB9215

RYN20/25/35CVMB9215

DAIKIN INDUSTRIES, LTD.

Head office:

Umeda Center Bldg., 4-12, Nakazaki-Nishi 2-chome,
Kita-ku, Osaka, 530-8323 Japan

Tokyo office:

Shinjuku Sumitomo Bldg., 6-1 Nishi-Shinjuku
2-chome, Shinjuku-ku, Tokyo, 163-0235 Japan

DAIKIN EUROPE NV

Zandvoordestraat 300, B-8400 Oostende, Belgium