

Service Manual



Design, Installation & Testing Instruction R-410A Heat Pump 50Hz/60Hz Cooling Only 50Hz



RXYQ5PY1(E)	RXYQ5PYL(E)	RXQ5PY1
RXYQ8PY1(E)	RXYQ8PYL(E)	RXQ8PY1
RXYQ10PY1(E)	RXYQ10PYL(E)	RXQ10PY1
RXYQ12PY1(E)	RXYQ12PYL(E)	RXQ12PY1
RXYQ14PY1(E)	RXYQ14PYL(E)	RXQ14PY1
RXYQ16PY1(E)	RXYQ16PYL(E)	RXQ16PY1
RXYQ18PY1(E)	RXYQ18PYL(E)	RXQ18PY1
RXYQ20PY1(E)	RXYQ20PYL(E)	RXQ20PY1
RXYQ22PY1(E)	RXYQ22PYL(E)	RXQ22PY1
RXYQ24PY1(E)	RXYQ24PYL(E)	RXQ24PY1
RXYQ26PY1(E)	RXYQ26PYL(E)	RXQ26PY1
RXYQ28PY1(E)	RXYQ28PYL(E)	RXQ28PY1
RXYQ30PY1(E)	RXYQ30PYL(E)	RXQ30PY1
RXYQ32PY1(E)	RXYQ32PYL(E)	RXQ32PY1
RXYQ34PY1(E)	RXYQ34PYL(E)	RXQ34PY1
RXYQ36PY1(E)	RXYQ36PYL(E)	RXQ36PY1
RXYQ38PY1(E)	RXYQ38PYL(E)	RXQ38PY1
RXYQ40PY1(E)	RXYQ40PYL(E)	RXQ40PY1
RXYQ42PY1(E)	RXYQ42PYL(E)	RXQ42PY1
RXYQ44PY1(E)	RXYQ44PYL(E)	RXQ44PY1
RXYQ46PY1(E)	RXYQ46PYL(E)	RXQ46PY1
RXYQ48PY1(E)	RXYQ48PYL(E)	RXQ48PY1
RXYQ50PY1(E)	RXYQ50PYL(E)	RXQ50PY1
RXYQ52PY1(E)	RXYQ52PYL(E)	RXQ52PY1
RXYQ54PY1(E)	RXYQ54PYL(E)	RXQ54PY1

VRV[®] III

R-410A Series

Part 1	General Information	1
1.	Product Outline	2
1.1	Model Names of Indoor/Outdoor Units	2
1.2	External Appearance	3
1.3	Combination of Outdoor Units	6
1.4	Model Selection	10
2.	Points to Bear in Mind at the System Design	12
2.1	Points Relating to the Performance of the Air Conditioning Units	12
2.2	The Installation is of Vital Importance	14
2.3	Striking a Balance between System Installation and General Construction Work (Comprehensive Flow Chart)15	
2.4	Points to Bear in Mind when Preparing the Contract Drawings	16
3.	Installation	19
3.1	Step by Step Installation Procedure	19
3.2	Work Involved in Individual Operations and Points to be Borne in Mind	20
4.	Test Operation	82
4.1	Procedure and Outline	82
4.2	Operation when Power is Turned On	86
4.3	Outdoor Unit PC Board Layout.....	87
4.4	Field Setting	88
5.	Caution for Refrigerant Leaks	124
5.1	Caution for Refrigerant Leaks	124
6.	Hand Over to Customer	127
6.1	Operational Steps.....	127
7.	Appendix	128
7.1	Operating Noise of Indoor Units	128
7.2	Piping Installation Point	130
7.3	Example of Connection (R-410A type).....	132
7.4	Refrigerant Branch Kit Selection	136
7.5	Pipe Size Selection	139
7.6	How to Calculate the Additional Refrigerant to be Charged.....	141
7.7	Size of Main Gas and Liquid Pipes and Allowable Length	142
7.8	Record of Field Setting and Additional Refrigerant Charge	144
7.9	Outdoor Unit Multi Connection Piping Kit	145
7.10	REFNET Joint and Header.....	160
7.11	VRV Inspection Sheet	165
7.12	Piping System Diagrams	170
7.13	Wiring Diagrams (Heat Pump 50Hz/60Hz, Cooling Only 50Hz).....	182
7.14	Bad Examples and Good Examples in Installation.....	195
7.15	Malfunction of Transmission Examples.....	210

Part 2 Installation Manual 213

1. Heat Pump / Cooling Only 50Hz (RX(Y)Q5~54P).....	214
1.1 First of All	215
1.2 Introduction.....	218
1.3 Selection of Location	222
1.4 Inspecting and Handling the Unit	224
1.5 Placing the Unit	225
1.6 Refrigerant Piping.....	226
1.7 Field Wiring	238
1.8 Air Tight Test and Vacuum Drying	246
1.9 Pipe Insulation.....	248
1.10 Checking of Device and Installation Conditions	249
1.11 Additional Refrigerant Charge and Check Operation	250
1.12 Onsite Settings	257
1.13 Test Run.....	258
1.14 Caution for Refrigerant Leaks	259
2. Heat Pump 60Hz (RXYQ5~54P).....	261
2.1 First of All	262
2.2 Introduction.....	265
2.3 Selection of Location	269
2.4 Inspecting and Handling the Unit	271
2.5 Placing the Unit	272
2.6 Refrigerant Piping.....	273
2.7 Field Wiring	286
2.8 Air Tight Test and Vacuum Drying	294
2.9 Pipe Insulation.....	296
2.10 Checking of Device and Installation Conditions	297
2.11 Additional Refrigerant Charge and Check Operation	298
2.12 Onsite Settings	305
2.13 Test Run.....	306
2.14 Caution for Refrigerant Leaks	307

Part 3 Operation Manual 309

1. Heat Pump / Cooling Only 50Hz (RX(Y)Q5~54P)	310
1.1 Safety Cautions	311
1.2 Specifications	312
1.3 What to do before Operation	312
1.4 Remote Control and COOL/HEAT Selector: Name and Function of Each Switch and Display (Refer to figure 2 and 3).....	313
1.5 Operation Range	313
1.6 Operation Procedure	313
1.7 Optimum Operation	317
1.8 Seasonal Maintenance	317
1.9 Following Symptoms are not Air Conditioner Troubles.....	317
1.10 Trouble Shooting	319
2. Heat Pump 60Hz (RXYQ5~54P).....	321
2.1 Safety Cautions	322
2.2 Specifications	323
2.3 What to do before Operation	323
2.4 Remote Control and COOL/HEAT Selector: Name and Function of	

- each Switch and Display (Refer to figure 2 and 3) 323
- 2.5 Operation Range 324
- 2.6 Operation Procedure 324
- 2.7 Optimum Operation 328
- 2.8 Seasonal Maintenance 328
- 2.9 Following Symptoms are not Air Conditioner Troubles..... 328
- 2.10 Trouble Shooting 330

Part 4 Precautions for New Refrigerant (R-410A) 333

- 1. Precautions for New Refrigerant (R-410A)334
 - 1.1 Outline334
 - 1.2 Refrigerant Cylinders.....336
 - 1.3 Service Tools.....337

Index i

Drawings & Flow Charts iii

Preface

This system is a modular zone controllable air conditioning system of great sophistication which is capable of assembly in a variety of different configurations. It would, however, be no exaggeration to say that the full potential of the systems functions can only be achieved in combination with the skills of those involved in the design of the equipment itself and those responsible for the installation work.

As the move towards intelligent buildings has gathered momentum, so we have also been seeing ever more a growing demand for a wider range of independently controllable building related functions.

Against this background there have also quite naturally been calls for the development of more distributed types of air conditioning systems while at the same time taking full account of the need to use energy economically by demand matching in view of the huge annual increases in the demand for electric power seen in recent years.

We have therefore prepared this installation manual to enable installation work to be handled confidently on the basis of a clear understanding of the special features of this system. We have paid particular attention to points of difference in installation procedure between this system and the more traditional package and room air conditioning system.

The manual is designed specifically to cater for those supervising installation work and concentrates on those products which are currently on the market. Essential points which need to be taken into consideration when designing an appropriate configuration for the system and in each of the separate installation processes have also been included.

We have also added a section covering problems which have arisen in connection with installation work undertaken to date in an attempt to prevent the recurrence of the same problems.

Please be sure to read this manual thoroughly before starting installation work in order to ensure that all such work is carried out with maximum efficiency and to maximum effect.

The following technical documents are also available from Daikin. Please use these documents together with this manual to conduct efficient servicing.

Title	Pub.:No.	Published In
Service Manual VRVIII R-410A Heat Pump 50Hz P Series	Si34-601	Jun., 2006
Service Manual VRVIII R-410A Heat Pump 60Hz P Series	Si34-605	Feb., 2007
Service Manual VRVIII R-410A Cooling Only 50Hz P Series	Si34-704	Mar., 2007

May, 2007

After Sales Service Division

Part 1

General Information

1. Product Outline	2
1.1 Model Names of Indoor/Outdoor Units	2
1.2 External Appearance	3
1.3 Combination of Outdoor Units	6
1.4 Model Selection	10
2. Points to Bear in Mind at the System Design	12
2.1 Points Relating to the Performance of the Air Conditioning Units	12
2.2 The Installation is of Vital Importance	14
2.3 Striking a Balance between System Installation and General Construction Work (Comprehensive Flow Chart)	15
2.4 Points to Bear in Mind when Preparing the Contract Drawings	16
3. Installation	19
3.1 Step by Step Installation Procedure	19
3.2 Work Involved in Individual Operations and Points to be Borne in Mind	20
4. Test Operation	82
4.1 Procedure and Outline	82
4.2 Operation when Power is Turned On	86
4.3 Outdoor Unit PC Board Layout	87
4.4 Field Setting	88
5. Caution for Refrigerant Leaks	124
5.1 Caution for Refrigerant Leaks	124
6. Hand Over to Customer	127
6.1 Operational Steps	127
7. Appendix	128
7.1 Operating Noise of Indoor Units	128
7.2 Piping Installation Point	130
7.3 Example of Connection (R-410A type)	132
7.4 Refrigerant Branch Kit Selection	136
7.5 Pipe Size Selection	139
7.6 How to Calculate the Additional Refrigerant to be Charged	141
7.7 Size of Main Gas and Liquid Pipes and Allowable Length	142
7.8 Record of Field Setting and Additional Refrigerant Charge	144
7.9 Outdoor Unit Multi Connection Piping Kit	145
7.10 REFNET Joint and Header	160
7.11 VRV Inspection Sheet	165
7.12 Piping System Diagrams	170
7.13 Wiring Diagrams (Heat Pump 50Hz/60Hz, Cooling Only 50Hz)	182
7.14 Bad Examples and Good Examples in Installation	195
7.15 Malfunction of Transmission Examples	210

1. Product Outline

1.1 Model Names of Indoor/Outdoor Units

Indoor Units

Type		Model Name											Power Supply
Ceiling Mounted Cassette Type (Double Flow)	FXCQ	20M	25M	32M	40M	50M	63M	80M	—	125M	—	—	VE
Ceiling Mounted Cassette Type (Multi Flow)	FXFQ	—	25M	32M	40M	50M	63M	80M	100M	125M	—	—	
600×600 Ceiling Mounted Cassette Type	FXZQ	20M	25M	32M	40M	50M	—	—	—	—	—	—	V1
Ceiling Mounted Cassette Corner Type	FXKQ	—	25MA	32MA	40MA	—	63MA	—	—	—	—	—	VE
Slim Ceiling Mounted Duct Type	FXDQ-PVE	20P	25P	32P	—	—	—	—	—	—	—	—	
	FXDQ-PVET	20P	25P	32P	—	—	—	—	—	—	—	—	
	FXDQ-NAVE	20NA	25NA	32NA	40NA	50NA	63NA	—	—	—	—	—	
	FXDQ-NVET	20N	25N	32N	40N	50N	63N	—	—	—	—	—	
Ceiling Mounted Built-In Type	FXSQ	20M	25M	32M	40M	50M	63M	80M	100M	125M	—	—	
Ceiling Mounted Duct Type	FXMQ	—	—	—	40MA	50MA	63MA	80MA	100MA	125MA	200MA	250MA	
Ceiling Suspended Type	FXHQ	—	—	32MA	—	—	63MA	—	100MA	—	—	—	
Wall Mounted Type	FXAQ	20MA	25MA	32MA	40MA	50MA	63MA	—	—	—	—	—	
Floor Standing Type	FXLQ	20MA	25MA	32MA	40MA	50MA	63MA	—	—	—	—	—	
Concealed Floor Standing Type	FXNQ	20MA	25MA	32MA	40MA	50MA	63MA	—	—	—	—	—	
Outdoor Air Processing Unit	FXMQ-MF	—	—	—	—	—	—	—	—	125MF	200MF	250MF	V1
Ceiling Suspended Cassette Type	FXUQ	—	—	—	—	—	—	71MA	100MA	125MA	—	—	
Connection Unit for FXUQ	BEVQ-MA	—	—	—	—	—	—	71MA	100MA	125MA	—	—	VE

Note: FXDQ has following 2 Series, as show below.

FXDQ-P, N(A)VET: without Drain Pump (For General, Asia: except for EU, China and Australia)

FXDQ-P, N(A)VE: with Drain Pump

BEV unit is required for each indoor unit.

MA, NA: RoHS Directive models; Specifications, Dimensions and other functions are not changed compared with M, N type.

Outdoor Units

Normal Series

Series	Model Name											Power Supply
Heat Pump	RX(Y)Q	5P	8P	10P	12P	14P	16P	18P	20P	22P	Y1(E) YL(E)	
		24P	26P	28P	30P	32P	34P	36P	38P	40P		
		42P	44P	46P	48P	50P	52P	54P				

Note: There is no YL(E) power supply in Cooling only model.

High COP Series (Energy Saving Series)













Series	Model Name										Power Supply
Heat Pump	RX(Y)Q	16PH	18PH	24PH	26PH	28PH	30PH	32PH	34PH	36PH	Y1(E) YL(E)
		38PH	40PH	42PH	44PH	46PH	48PH	50PH			

Note: There is no YL(E) power supply in Cooling only model.

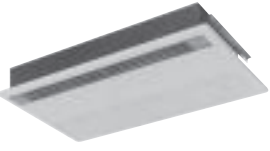
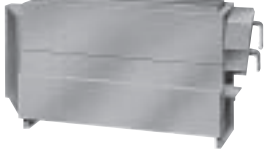
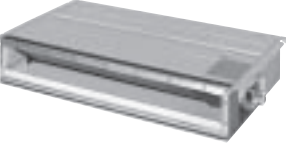
E : The unit with anti corrosion treatment
 VE : 1φ, 220~240V, 50Hz, 1φ, 220V, 60Hz
 V1 : 1φ, 220~240V, 50Hz
 Y1 : 3φ, 380~415V, 50Hz
 YL : 3φ, 380V, 60Hz







1.2 External Appearance

1.2.1 Indoor Units Heat Pump: 50Hz/60Hz, Cooling Only: 50Hz





<p>Ceiling Mounted Cassette Type (Double Flow)</p> <p>FXCQ20M FXCQ25M FXCQ32M FXCQ40M FXCQ50M FXCQ63M FXCQ80M FXCQ125M</p> 	<p>Ceiling Suspended Type</p> <p>FXHQ32MA FXHQ63MA FXHQ100MA</p> 
<p>Ceiling Mounted Cassette Type (Multi Flow)</p> <p>FXFQ25M FXFQ32M FXFQ40M FXFQ50M FXFQ63M FXFQ80M FXFQ100M FXFQ125M</p> 	<p>Wall Mounted Type</p> <p>FXAQ20MA FXAQ25MA FXAQ32MA FXAQ40MA FXAQ50MA FXAQ63MA</p> 
<p>600×600 Ceiling Mounted Cassette Type (Multi Flow)</p> <p>FXZQ20M FXZQ25M FXZQ32M FXZQ40M FXZQ50M</p> 	<p>Floor Standing Type</p> <p>FXLQ20MA FXLQ25MA FXLQ32MA FXLQ40MA FXLQ50MA FXLQ63MA</p> 
<p>Ceiling Mounted Cassette Corner Type</p> <p>FXKQ25MA FXKQ32MA FXKQ40MA FXKQ63MA</p> 	<p>Concealed Floor Standing Type</p> <p>FXNQ20MA FXNQ25MA FXNQ32MA FXNQ40MA FXNQ50MA FXNQ63MA</p> 
<p>Slim Ceiling Mounted Duct Type</p> <p>FXDQ20P FXDQ20N(A) FXDQ25P FXDQ25N(A) FXDQ32P FXDQ32N(A) FXDQ40N(A) FXDQ50N(A) FXDQ63N(A) with Drain Pump (VE) without Drain Pump (VET)</p> 	<p>Ceiling Suspended Cassette Type (Connection Unit Series)</p> <p>FXUQ71MA + BEVQ71MA FXUQ100MA + BEVQ100MA FXUQ125MA + BEVQ125MA</p> <p>Connection Unit</p> 
<p>Ceiling Mounted Built-In Type</p> <p>FXSQ20M FXSQ25M FXSQ32M FXSQ40M FXSQ50M FXSQ63M FXSQ80M FXSQ100M FXSQ125M</p> 	<p>Outdoor air processing unit</p> <p>FXMQ125MF FXMQ200MF FXMQ250MF</p> 
<p>Ceiling Mounted Duct Type</p> <p>FXMQ40MA FXMQ50MA FXMQ63MA FXMQ80MA FXMQ100MA FXMQ125MA FXMQ200MA FXMQ250MA</p>  <p>FXMQ40~125M</p>  <p>FXMQ200 · 250M</p>	

1.2.2 Outdoor Units Heat Pump: 50Hz/60Hz, Cooling Only: 50Hz

Normal Series (Space Saving Series)

H/P	RXYQ5P	H/P	RXYQ8P, 10P(12P:EUROPE)	H/P	RXYQ12P, 14P, 16P, 18P
C/O	RXQ5P	C/O	RXQ8P, 10P	C/O	RXQ12P, 14P, 16P,18P
 <p>5HP</p>		 <p>8, 10HP</p>		 <p>12, 14, 16, 18HP</p>	
H/P	RXYQ20P, 22P, 24P, 26P, 28P	H/P	RXYQ30P, 32P, 34P, 36P		
C/O	RXQ20P, 22P, 24P, 26P, 28P	C/O	RXQ30P, 32P, 34P, 36P		
 <p>20, 22, 24, 26, 28HP</p>		 <p>30, 32, 34, 36HP</p>			
H/P	RXYQ38P, 40P, 42P, 44P, 46P	H/P	RXYQ48P, 50P, 52P, 54P		
C/O	RXQ38P, 40P, 42P, 44P, 46P	C/O	RXQ48P, 50P, 52P, 54P		
 <p>38, 40, 42, 44, 46HP</p>		 <p>48, 50, 52, 54HP</p>			

High COP Series (Energy Saving Series)

H/P	RXYQ16PH, 18PH	H/P	RXYQ24PH, 26PH
C/O	RXQ16PH, 18PH	C/O	RXQ24PH, 26PH
 <p>16, 18HP</p>		 <p>24, 26HP</p>	
H/P	RXYQ28PH, 30PH	H/P	RXYQ32PH, 34PH
C/O	RXQ28PH, 30PH	C/O	RXQ32PH, 34PH
 <p>28, 30HP</p>		 <p>32, 34HP</p>	
H/P	RXYQ36PH, 38PH, 40PH, 42PH, 44PH, 46PH, 48PH, 50PH		
C/O	RXQ36PH, 38PH, 40PH, 42PH, 44PH, 46PH, 48PH, 50PH		
 <p>36, 38, 40, 42, 44, 46, 48, 50HP</p>			

1.3 Combination of Outdoor Units

Normal Series (Space Saving Series)

System Capacity	Number of units	Module							Outdoor Unit Multi Connection Piping Kit (Option)
		5	8	10	12	14	16	18	
5HP	1	●							—
8HP	1		●						
10HP	1			●					
12HP	1				●				
14HP	1					●			
16HP	1						●		
18HP	1							●	
20HP	2		●		●				BHFP22P100
22HP	2			●	●				
24HP	2		●				●		
26HP	2		●					●	
28HP	2			●				●	
30HP	2				●			●	
32HP	2						●●		
34HP	2						●	●	
36HP	2							●●	
38HP	3		●		●			●	BHFP22P151
40HP	3		●				●●		
42HP	3		●				●	●	
44HP	3		●					●●	
46HP	3			●				●●	
48HP	3				●			●●	
50HP	3					●		●●	
52HP	3						●	●●	
54HP	3							●●●	

i **Note:** For multiple connection of 20HP system or more, an optional Daikin Outdoor Unit Multi Connection Piping Kit is required.

High COP Series (Energy Saving Series)

System Capacity	Number of units	Module						Outdoor Unit Multi Connection Piping Kit (Option)
		8	10	12	14	16	18	
16HP	2	●●						BHFP22P100
18HP	2	●	●					
24HP	3	●●●						BHFP22P151
26HP	3	●●	●					
28HP	3	●●		●				
30HP	3	●	●	●				
32HP	3	●		●●				
34HP	3		●	●●				
36HP	3			●●●				
38HP	3			●●	●			
40HP	3			●●		●		
42HP	3			●●			●	
44HP	3			●		●●		
46HP	3			●		●	●	
48HP	3					●●●		
50HP	3					●●	●	



Note: For multiple connection of 16HP system or more, an optional Daikin Outdoor Unit Multi Connection Piping Kit is required.

Connectable Indoor Unit

Type		Model Name											Power Supply
Ceiling Mounted Cassette Type (Double Flow)	FXCQ	20M	25M	32M	40M	50M	63M	80M	—	125M	—	—	VE
Ceiling Mounted Cassette Type (Multi Flow)	FXFQ	—	25M	32M	40M	50M	63M	80M	100M	125M	—	—	
600×600 Ceiling Mounted Cassette Type (Multi Flow)	FXZQ	20M	25M	32M	40M	50M	—	—	—	—	—	—	V1
Ceiling Mounted Cassette Corner Type	FXKQ	—	25MA	32MA	40MA	—	63MA	—	—	—	—	—	VE
Slim Ceiling Mounted Duct Type	FXDQ-PVE	20P	25P	32P	—	—	—	—	—	—	—	—	
	FXDQ-PVET	20P	25P	32P	—	—	—	—	—	—	—	—	
	FXDQ-NAVE	20NA	25NA	32NA	40NA	50NA	63NA	—	—	—	—	—	
	FXDQ-NVET	20N	25N	32N	40N	50N	63N	—	—	—	—	—	
Ceiling Mounted Built-In Type	FXSQ	20M	25M	32M	40M	50M	63M	80M	100M	125M	—	—	
Ceiling Mounted Duct Type	FXMQ	—	—	—	40MA	50MA	63MA	80MA	100MA	125MA	200MA	250MA	
Ceiling Suspended Type	FXHQ	—	—	32MA	—	—	63MA	—	100MA	—	—	—	
Wall Mounted Type	FXAQ	20MA	25MA	32MA	40MA	50MA	63MA	—	—	—	—	—	
Floor Standing Type	FXLQ	20MA	25MA	32MA	40MA	50MA	63MA	—	—	—	—	—	
Concealed Floor Standing Type	FXNQ	20MA	25MA	32MA	40MA	50MA	63MA	—	—	—	—	—	

Note: FXDQ has following 2 Series, as shown below.

FXDQ-P, N(A)VET: without Drain Pump (For General, Asia: except for EU, China and Australia)

FXDQ-P, N(A)VE : with Drain Pump

FXZQ : only for EU, Australia

Indoor unit capacity

New refrigerant model code	P20 type	P25 type	P32 type	P40 type	P50 type	P63 type	P80 type	P100 type	P125 type	P200 type	P250 type
Selecting model capacity	2.2 kW	2.8 kW	3.5 kW	4.5 kW	5.6 kW	7.0 kW	9.0 kW	11.2 kW	14.0 kW	22.4 kW	28.0 kW
Equivalent output	0.8HP	1HP	1.25HP	1.6HP	2.0HP	2.5HP	3.2HP	4HP	5HP	8HP	10HP

Use the above tables to determine the capacities of indoor units to be connected. Make sure the total capacity of indoor units connected to each outdoor unit is within the specified value (kW).

- The total capacity of connected indoor units must be within a range of 50 to 130% of the rated capacity of the outdoor unit.
- In some models, it is not possible to connect the maximum number of connectable indoor units. Select models so the total capacity of connected indoor units conforms to the specification.

Differences from Conventional Models

Item	Differences		
	Object	New model (P Model)	Conventional model (MA Model)
Compressor	Connection of equalizer oil pipe	<ul style="list-style-type: none"> ● NONE (No particular changes in terms of service) 	<ul style="list-style-type: none"> ● YES
Workability	Equalizer oil pipe for multi-outdoor-unit system	<ul style="list-style-type: none"> ● NONE 	<ul style="list-style-type: none"> ● YES
	Procedure for calculating refrigerant refilling quantity	<ul style="list-style-type: none"> ● Refilling quantity due to piping length + Adjustment quantity according to models of outdoor units 	<ul style="list-style-type: none"> ● Refilling quantity due to piping length - Adjustment quantity according to models of outdoor units
Optional accessories	Branch pipe for outdoor unit connection	<ul style="list-style-type: none"> ● Y branch Type: BHFP22P100/151 	<ul style="list-style-type: none"> ● T branch Type: BHFP22MA90/135

1.4 Model Selection

VRV III Heat Pump: 50Hz/60Hz, Cooling Only: 50Hz

Connectable indoor units number and capacity

Normal Series

HP	5HP	8HP	10HP	12HP	14HP	16HP	18HP
System name	RX(Y)Q5P	RX(Y)Q8P	RX(Y)Q10P	RX(Y)Q12P	RX(Y)Q14P	RX(Y)Q16P	RX(Y)Q18P
Outdoor unit 1	RX(Y)Q5P	RX(Y)Q8P	RX(Y)Q10P	RX(Y)Q12P	RX(Y)Q14P	RX(Y)Q16P	RX(Y)Q18P
Outdoor unit 2	–	–	–	–	–	–	–
Outdoor unit 3	–	–	–	–	–	–	–
Total number of connectable indoor units	8	13	16	19	23	26	29
Total capacity of connectable indoor units (kW)	7.00~18.20	11.20~29.12	14.00~36.40	16.75~43.55	20.00~52.00	22.40~58.24	25.20~65.52

HP	20HP	22HP	24HP	26HP	28HP	30HP	32HP
System name	RX(Y)Q20P	RX(Y)Q22P	RX(Y)Q24P	RX(Y)Q26P	RX(Y)Q28P	RX(Y)Q30P	RX(Y)Q32P
Outdoor unit 1	RX(Y)Q8P	RX(Y)Q10P	RX(Y)Q8P	RX(Y)Q8P	RX(Y)Q10P	RX(Y)Q12P	RX(Y)Q16P
Outdoor unit 2	RX(Y)Q12P	RX(Y)Q12P	RX(Y)Q16P	RX(Y)Q18P	RX(Y)Q18P	RX(Y)Q18P	RX(Y)Q16P
Outdoor unit 3	–	–	–	–	–	–	–
Total number of connectable indoor units	32	35	39	42	45	48	52
Total capacity of connectable indoor units (kW)	27.95~72.67	30.75~79.95	33.60~87.36	36.40~94.64	39.15~101.79	41.95~109.07	44.70~116.22

HP	34HP	36HP	38HP	40HP	42HP	44HP	46HP
System name	RX(Y)Q34P	RX(Y)Q36P	RX(Y)Q38P	RX(Y)Q40P	RX(Y)Q42P	RX(Y)Q44P	RX(Y)Q46P
Outdoor unit 1	RX(Y)Q16P	RX(Y)Q18P	RX(Y)Q8P	RX(Y)Q8P	RX(Y)Q8P	RX(Y)Q8P	RX(Y)Q10P
Outdoor unit 2	RX(Y)Q18P	RX(Y)Q18P	RX(Y)Q12P	RX(Y)Q16P	RX(Y)Q16P	RX(Y)Q18P	RX(Y)Q18P
Outdoor unit 3	–	–	RX(Y)Q18P	RX(Y)Q16P	RX(Y)Q18P	RX(Y)Q18P	RX(Y)Q18P
Total number of connectable indoor units	55	58	61	64			
Total capacity of connectable indoor units (kW)	47.50~123.50	50.25~130.65	53.50~139.10	56.00~145.60	58.00~150.80	61.75~160.55	63.75~165.75

HP	48HP	50HP	52HP	54HP
System name	RX(Y)Q48P	RX(Y)Q50P	RX(Y)Q52P	RX(Y)Q54P
Outdoor unit 1	RX(Y)Q12P	RX(Y)Q14P	RX(Y)Q16P	RX(Y)Q18P
Outdoor unit 2	RX(Y)Q18P	RX(Y)Q18P	RX(Y)Q18P	RX(Y)Q18P
Outdoor unit 3	RX(Y)Q18P	RX(Y)Q18P	RX(Y)Q18P	RX(Y)Q18P
Total number of connectable indoor units	64			
Total capacity of connectable indoor units (kW)	67.50~175.50	69.50~180.70	71.50~185.90	73.50~191.10

High COP Series (Energy Saving Series)

HP	16HP	18HP
System name	RX(Y)Q16PH	RX(Y)Q18PH
Outdoor unit 1	RX(Y)Q8P	RX(Y)Q8P
Outdoor unit 2	RX(Y)Q8P	RX(Y)Q10P
Outdoor unit 3	–	–
Total number of connectable indoor units	26	29
Total capacity of connectable indoor units (kW)	22.40~58.24	25.20~65.52

HP	24HP	26HP	28HP	30HP	32HP
System name	RX(Y)Q24PH	RX(Y)Q26PH	RX(Y)Q28PH	RX(Y)Q30PH	RX(Y)Q32PH
Outdoor unit 1	RX(Y)Q8P	RX(Y)Q8P	RX(Y)Q8P	RX(Y)Q8P	RX(Y)Q8P
Outdoor unit 2	RX(Y)Q8P	RX(Y)Q8P	RX(Y)Q8P	RX(Y)Q10P	RX(Y)Q12P
Outdoor unit 3	RX(Y)Q8P	RX(Y)Q10P	RX(Y)Q12P	RX(Y)Q12P	RX(Y)Q12P
Total number of connectable indoor units	39	42	45	48	52
Total capacity of connectable indoor units (kW)	33.60~87.36	36.40~94.64	39.15~101.79	41.95~109.07	44.70~116.22

HP	34HP	36HP	38HP	40HP	42HP	44HP	46HP
System name	RX(Y)Q34PH	RX(Y)Q36PH	RX(Y)Q38PH	RX(Y)Q40PH	RX(Y)Q42PH	RX(Y)Q44PH	RX(Y)Q46PH
Outdoor unit 1	RX(Y)Q10P	RX(Y)Q12P	RX(Y)Q12P	RX(Y)Q12P	RX(Y)Q12P	RX(Y)Q12P	RX(Y)Q12P
Outdoor unit 2	RX(Y)Q12P	RX(Y)Q12P	RX(Y)Q12P	RX(Y)Q12P	RX(Y)Q12P	RX(Y)Q16P	RX(Y)Q16P
Outdoor unit 3	RX(Y)Q12P	RX(Y)Q12P	RX(Y)Q14P	RX(Y)Q16P	RX(Y)Q18P	RX(Y)Q16P	RX(Y)Q18P
Total number of connectable indoor units	55	58	61	64			
Total capacity of connectable indoor units (kW)	47.50~123.50	50.25~130.65	53.50~139.10	56.00~145.60	58.00~150.80	61.75~160.55	63.75~165.75

HP	48HP	50HP
System name	RX(Y)Q48PH	RX(Y)Q50PH
Outdoor unit 1	RX(Y)Q16P	RX(Y)Q16P
Outdoor unit 2	RX(Y)Q16P	RX(Y)Q16P
Outdoor unit 3	RX(Y)Q16P	RX(Y)Q18P
Total number of connectable indoor units	64	
Total capacity of connectable indoor units (kW)	67.50~175.50	69.50~180.70

2. Points to Bear in Mind at the System Design

2.1 Points Relating to the Performance of the Air Conditioning Units

A number of points need to be borne in mind at the system design stage in order to ensure the mechanical efficiency of the air conditioning units.

1. Path of refrigerant piping between outdoor and indoor units, height difference and pipe length.

- Path of refrigerant piping should be determined such that length of piping is kept to a minimum.
- Piping should be kept within permissible limits in terms of length and height difference.

2. Positioning of outdoor unit

- Position such that maintenance and repairs can be carried out. (leave room for servicing)
- Avoid reduction of airflow and short circuiting



- Avoid reduction of airflow and short circuiting

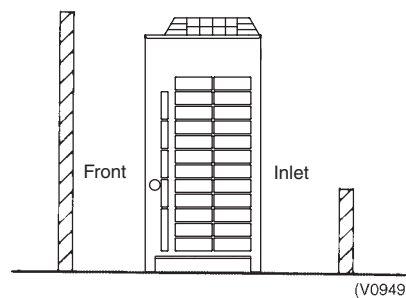

3. Positioning of indoor unit

- Position such that maintenance and repairs can be carried out. (inspection port positions and size check)
- Avoid short circuiting
- Ensure sufficient drain pipe gradient (need for drain-up kit etc.)
- In the case of a ceiling mounted type make sure ceiling depth is sufficient (need for high performance filter, etc.)

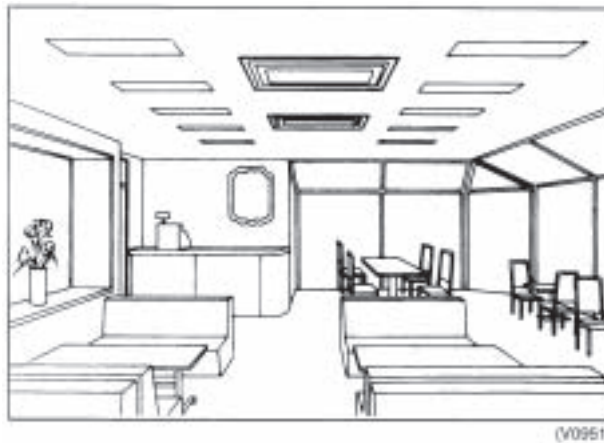

2.2 The Installation is of Vital Importance

The analysis of major installation problems experienced is shown below;

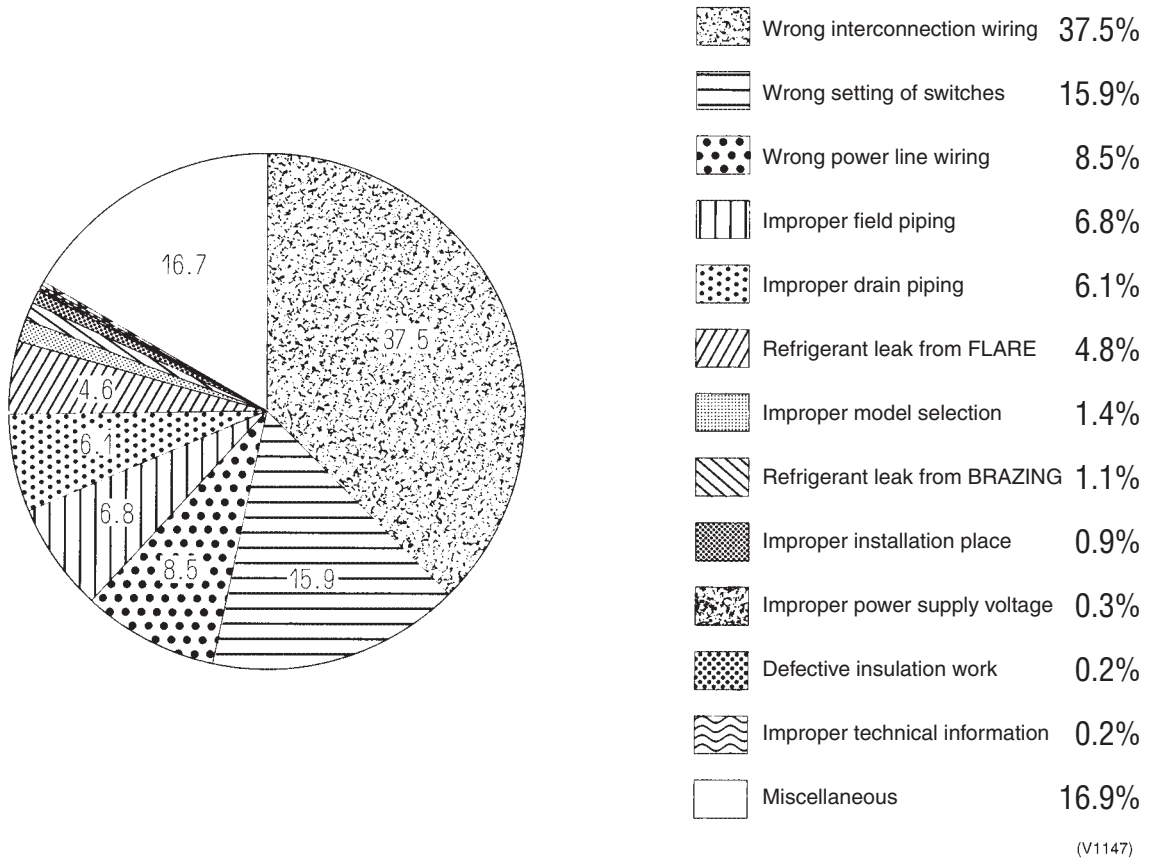

How these installation problems affect an equipment are shown below:

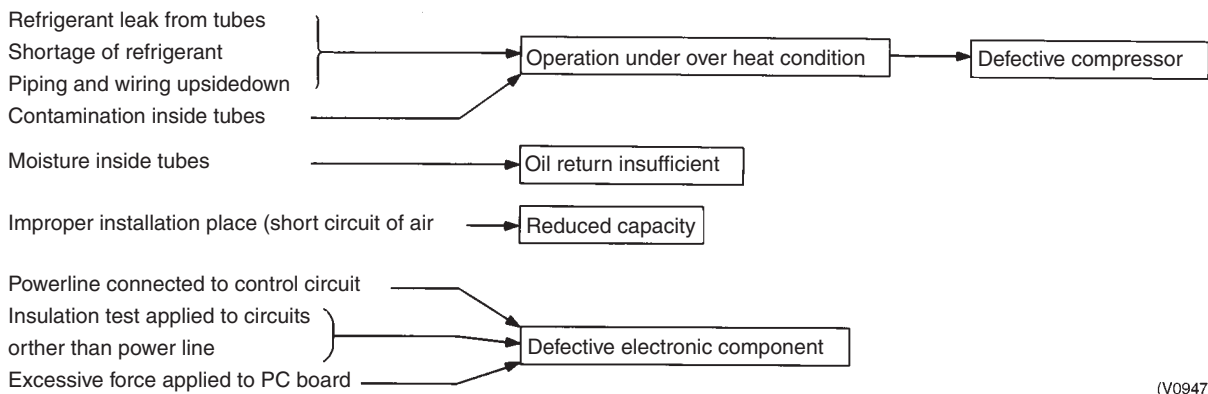

2.3 Striking a Balance between System Installation and General Construction Work (Comprehensive Flow Chart)

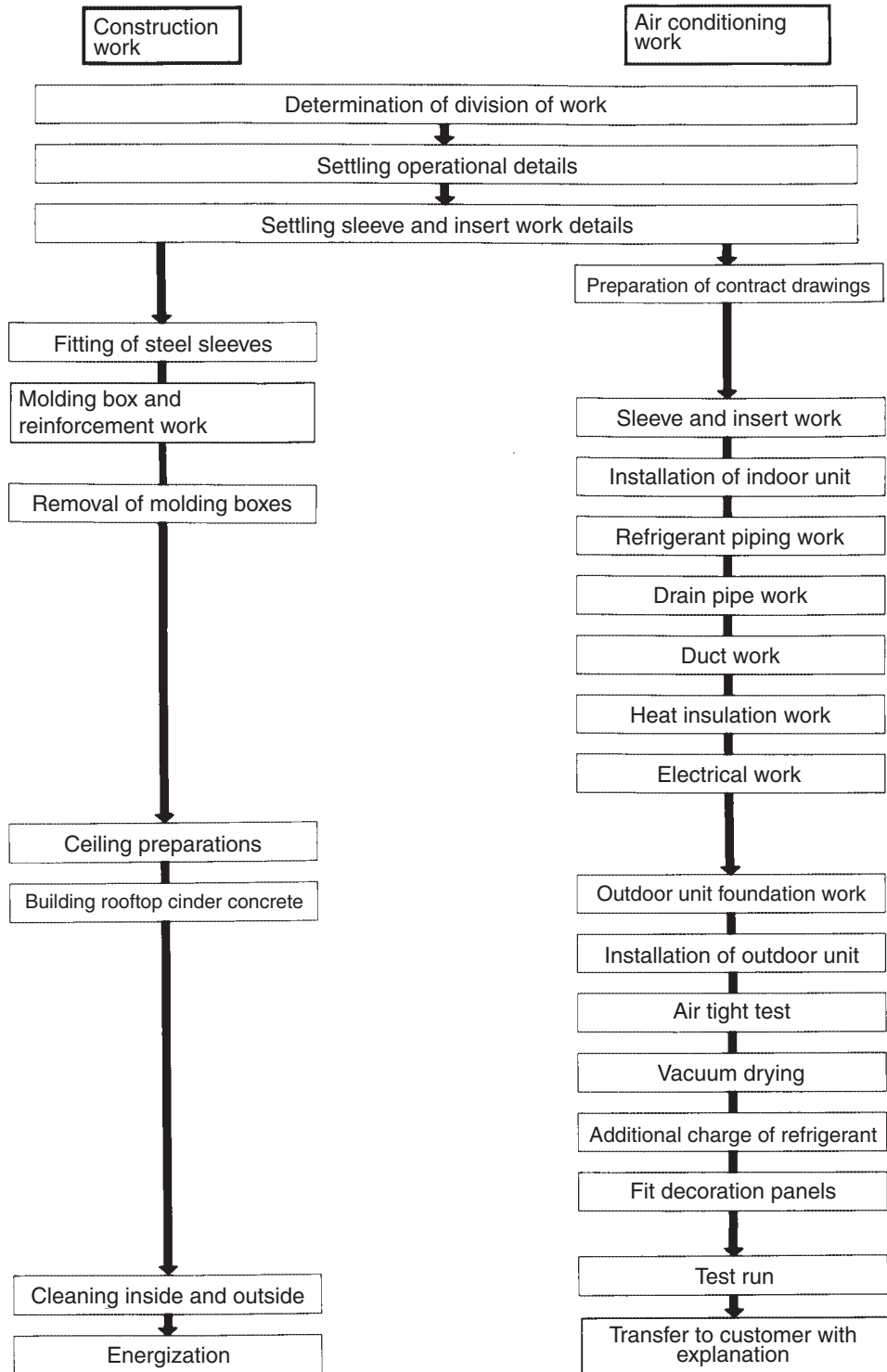

(V0952)



- Note:**
1. The division of the work should be thoroughly clarified. (This applies particularly to work relating to the connection of control wiring, fitting of remote control and central control panel, boundary work on areas such as connection of drain piping and humidification supply piping, inspection and foundation)
 2. Keep a constant check on the progress of the construction work to avoid deviations from the air conditioning work schedule.
 3. For sleeve and insert work the positions of ceiling girders should be confirmed and sleeve and insert requirement, hole diameters, positioning and numbers decided. This is particularly important in the case of sleeves for drain piping.

2.4 Points to Bear in Mind when Preparing the Contract Drawings

The following points should be borne in mind when preparing the contract drawings from the original drawings and the execution drawings.

The contract drawings for the air conditioning system are blueprints for the performance of the necessary work which are drawn up on the basis of the original drawings in such a way that a working balance is achieved between the specific requirements of each individual aspect of the work.

Contract Drawing

Objectives include:

- The drawings should be easily comprehensible to those carrying out the work.
- The contents of the drawings should not be subject to subsequent alteration.

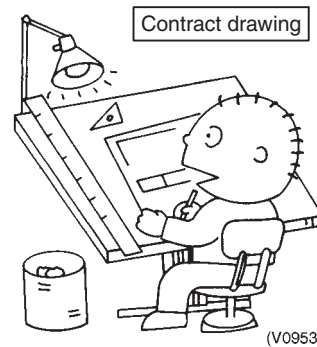

The following is a list of the main points to be considered when preparing contract drawings for the **VRV** III System and should be used as a reference during this stage of the work:

2.4.1 At the Contract Drawing Stage the Following Points are Critical!!

	Check points	
Arrangement of units	<ol style="list-style-type: none"> 1. Have you left the access passages clear and allowed sufficient room for servicing? 2. Have you taken full account of the possibility of short circuits? (Both indoor and outdoor units) 3. Can the air filters be replaced easily? 4. Have you indicated the size and location of the ceiling inspection ports? (Make sure there no other installations in the area above) 5. Have you taken into account the depth of the installation area? (In case of ceiling built-in type) 6. Have you specified the position of the indoor unit clearly? (Have you taken full account of relevant features of the local ventilation, humidity and lighting?) 	
Refrigerant piping	<ol style="list-style-type: none"> 1. Is the piping system correctly connected? 2. Are the rise and fall pipes correctly connected? 3. Are the lengths and height differences of the pipes within the recommended limits? 	
Operational control	<ol style="list-style-type: none"> 1. Are the interconnections between the piping and wiring of the indoor and outdoor units clearly shown? 2. Are the numbers of the local setting switches clearly shown? (Group No. and Unit No.) 3. Are the wiring connections between the remote control and the centralized and remote controls clearly shown? Refer to the notes relating to the preparation of the control wiring system diagrams (see next page) 4. Are the different types of wires clearly marked? 5. Are there any problems with the way the power supply cables and control wiring have been separated or bound together? 6. Are the inter-floor connections of the control wiring correct? 7. Is the position of the remote control clearly marked? 	
Miscellaneous	<ol style="list-style-type: none"> 1. Have you checked the gradient of the drain piping? (Must be at least 1/100) 	

(Example of a contract drawing)

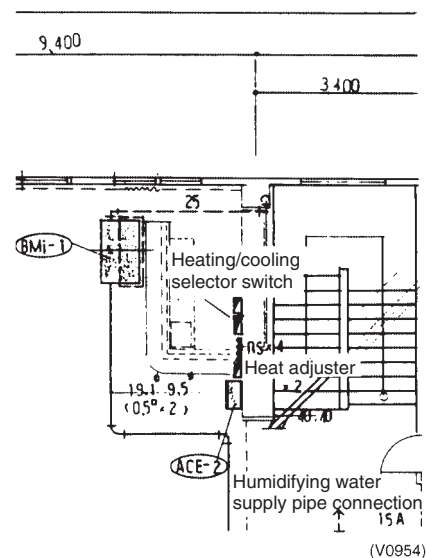

2.4.2 Main Considerations in Preparation of Control Circuit Diagrams

In addition to the design of the appropriate this system configuration it is also essential that the control system be made amply clear. If the system is designed and installed without a clear, comprehensive plan then problems are inevitably going to occur during the test run. Servicing too will become much more time consuming than necessary. However, if control circuit diagrams are prepared along with the contract drawings in order to make the total system clearly visible then the essential points relating to the electrical connections will be easily understood, the test run will go off without a hitch and the whole system will be rendered fully effective.

Step 1: Compiling a System List

1. Mark each outdoor unit with a code.
2. Add field settings and data for outdoor units, and outdoor unit No. if using sequential start.
3. Add the model number of each indoor unit connected to each refrigerant circuit.
4. Assign each indoor unit a code.
5. Fill in the location of each indoor unit.
6. Group indoor units controlled by one or two remote controls. (group or individual control).
7. Assign central group Nos. if using centralized control.
8. Add field settings and optional equipment for indoor units.
9. Add unit No. if making separate field settings for each indoor unit under group control.



Note: With the VRV III R-410A Heat Pump, Cooling Only Series, unit No. is determined through automatic addressing, therefore readout unit Nos. after activating the power.

Example: System list

Outdoor Unit		Indoor Unit						
Model Name (code)	Field Settings	Model Name	System Name	Location	Remote Control Group	Centralized Control Group No.	Unit No.	Optional equipment, field settings, etc.
RX(Y)Q16P (PAC1)	Cool/Heat selector: Indoor unit Low noise operation (L.N.O.P): Individual control Sequential start: ON Defrost: Earlier Sequential start No.	FXCQ32M	2F01	2nd floor office	A	1-00		
		FXSQ63M	2F02	2nd floor office	A	(1-00)		
		FXCQ40M	2F03	2nd floor office	A	(1-00)		
		FXHQ63MA	2F04	2nd floor office	B	1-01		
		FXCQ50M	2F05	2nd floor office	B	(1-01)		
RX(Y)Q18P (PAC2)	Cool/Heat selector: Indoor unit Low noise operation (L.N.O.P): Individual control Sequential start: ON Defrost: Earlier	FXSQ32M	3F01	3rd floor office	C	1-02		
		FXCQ40M	3F02	3rd floor office	C	(1-02)		
		FXSQ40M	3F03	3rd floor office	C	(1-02)		
		FXCQ50M	3F04	3rd floor office	D	1-03		

For details on field settings and centralized control group No., refer to the installation manual and system reference materials.

**Step 2:
Preparation of the
Control Circuit
Diagrams**

The following sequence should be followed in order to prepare control circuit diagrams in accordance with the system list which has already been completed:

- ① Diagrams should be prepared for each individual outdoor unit. The outdoor unit model number should be inserted into the diagram. (RX(Y)Q16P)
 - ② Insert name of refrigerant system. (PAC1, PAC2)
 - ③ Insert name of indoor unit. (FXCQ32M→CQ32M)
 - ④ Insert system name of indoor unit.
 - ⑤ Insert installation position. (Do this when demarcation is possible)
 - ⑥ Insert remote control control wiring. (Group) Indicated by solid line.Solid line.
 - ⑦ Insert centralized control wiring.Dotted line
 - ⑧ Insert Group No. (G No. for each indoor unit with U No. 0)
- The control circuit diagrams are now complete.

Example: Control circuit diagram

Example: Control circuit diagram

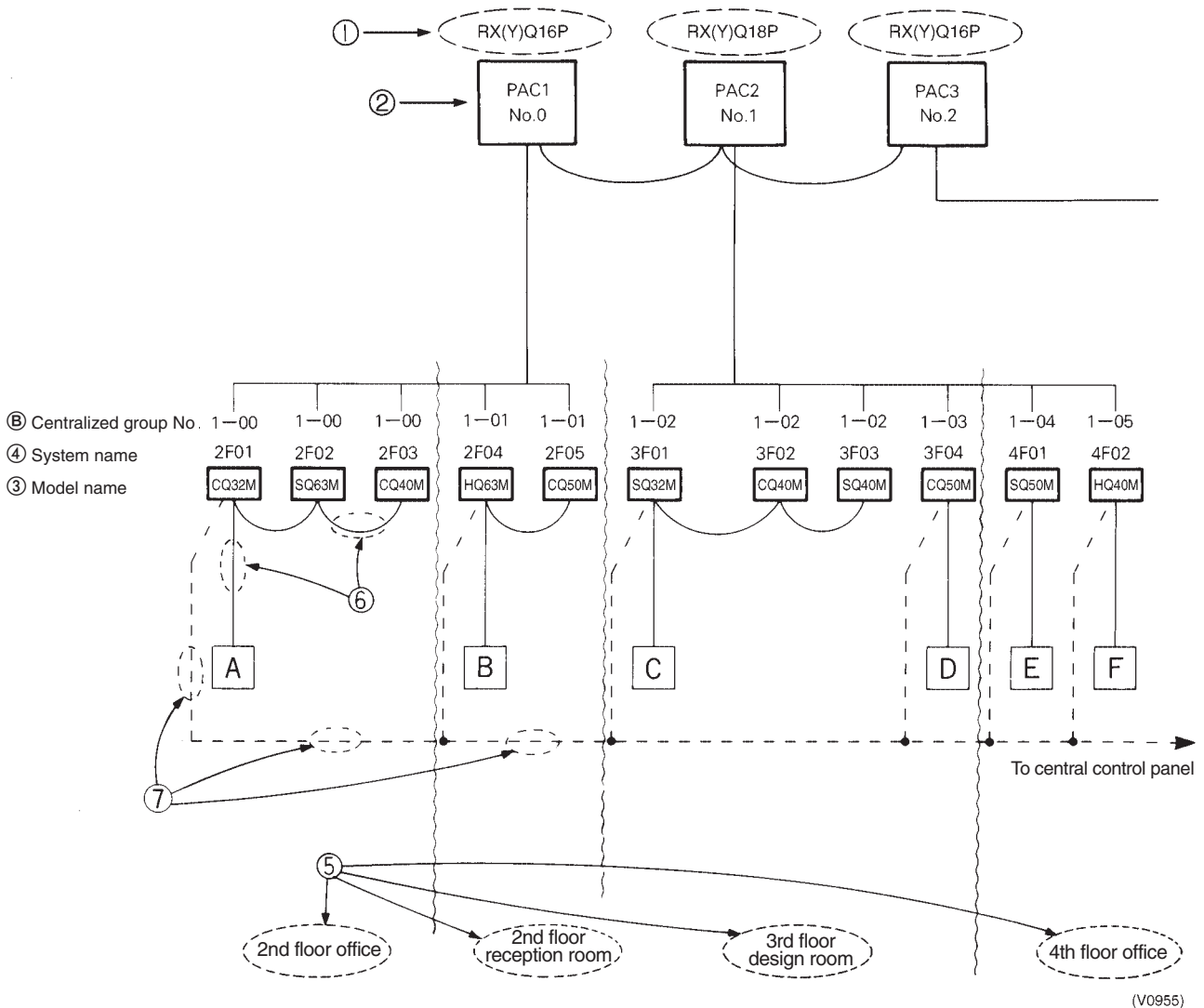

3. Installation

3.1 Step by Step Installation Procedure

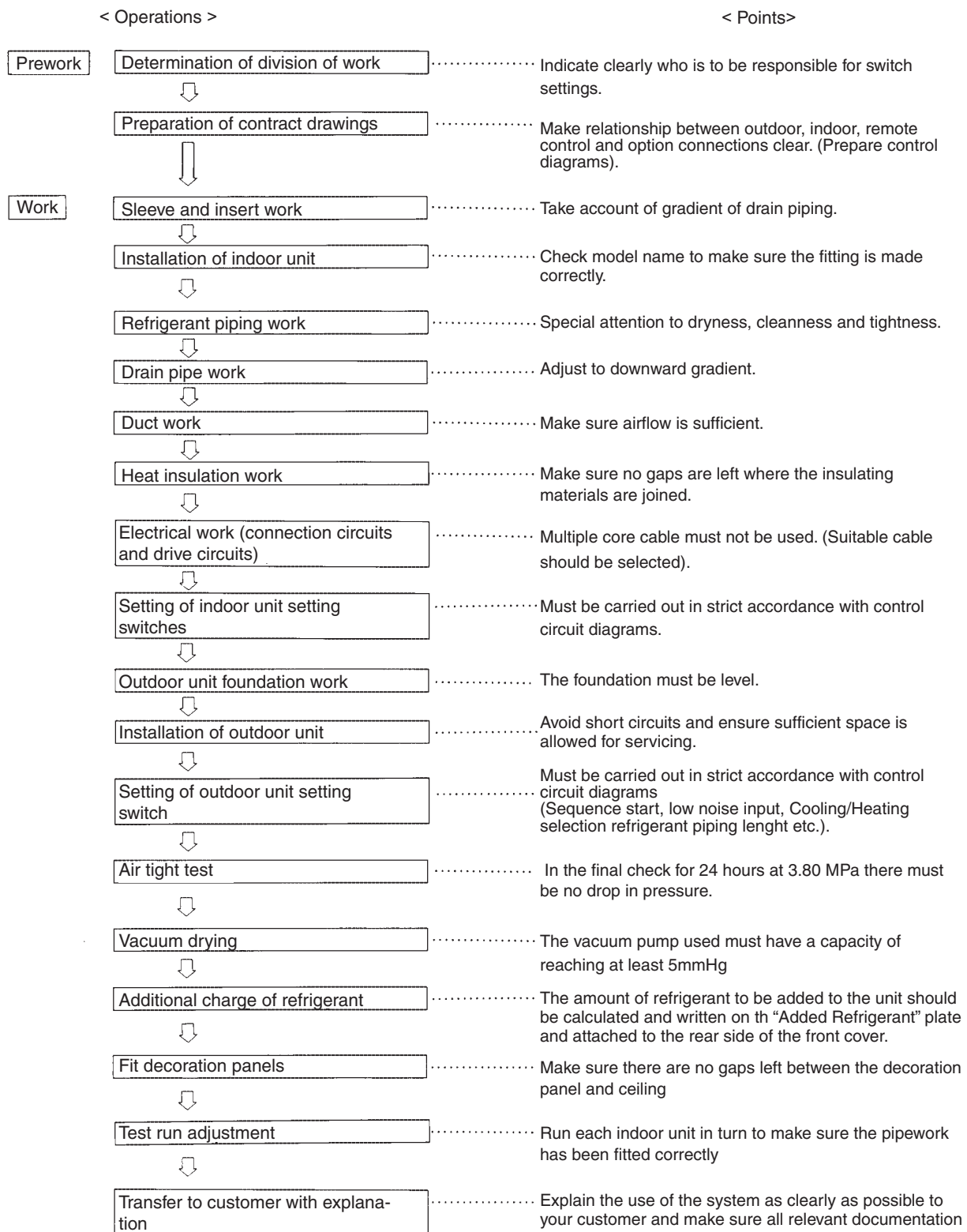

(V1351)

The above list indicates the order in which the individual work operations are normally carried out but this order may be varied where local conditions warrant such a change

3.2 Work Involved in Individual Operations and Points to be Borne in Mind

3.2.1 Sleeve and Insert Work

■ Operational steps

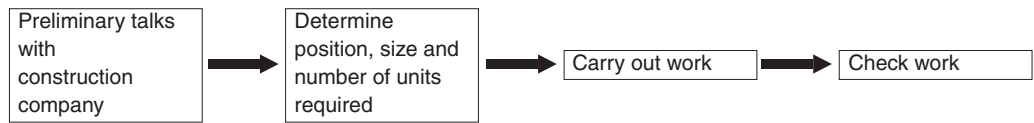

(V0957)

Positioning of the Pipe Holes

- a) The through holes for the drain piping should be positioned such that the pipes have a downward gradient. (The gradient must be at least 1/100. The thickness of the insulating materials must also be taken into consideration.)
- b) The diameter of the through holes for the refrigerant piping should include an allowance for the thickness of the heat insulation materials. (It is a good idea to think of the liquid and gas pipes as pairs.)
- c) Attention should be paid to the construction of the beam themselves since there are sometimes parts of the beam which cannot be used to accommodate through holes.

Example: Through holes in a reinforced concrete beam

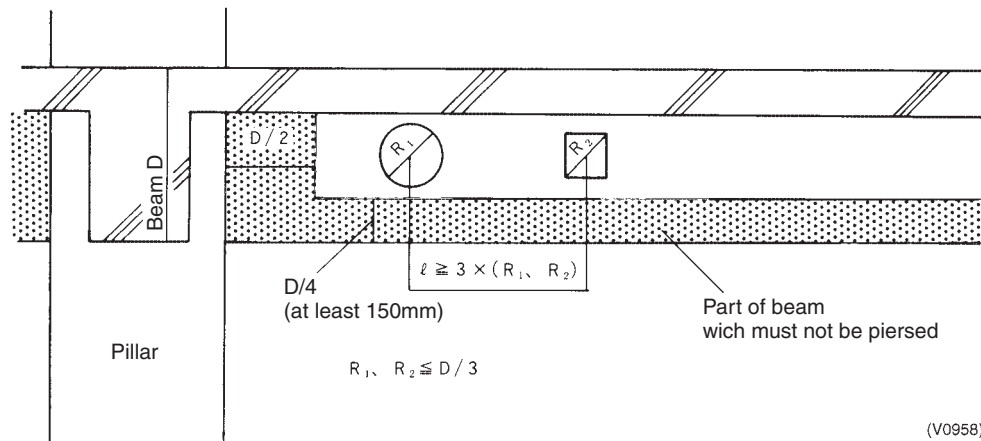

(V0958)

Positioning the Insert

- a) An insert is a metal tool which is inserted into a floor or a beam before the concrete is set such that fittings such as ducts, pipes or suspension bolts for hanging units can be fitted into place later. **The positions of the inserts must be decided early.**

Example: Steel insert

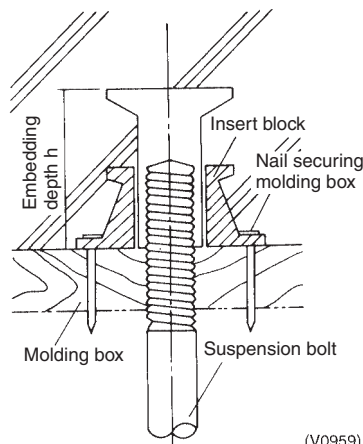

(V0959)

Important point:

- 1. The weight of the fitting to be suspended must be taken into account when choosing the insert.

3.2.2 Installation of Indoor Unit

■ Operational steps

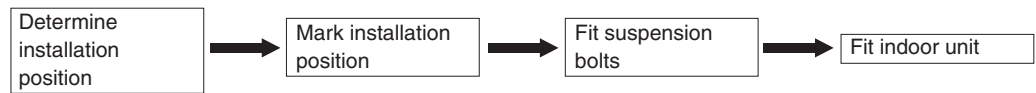

(V0960)

Positioning

3 essential points when installing an indoor unit

1. Height: Take care to account for final ceiling facing surface level
2. Level: Level fitting is essential. (within ± 1 degree of horizontal)
3. Direction: The unit must be fitted in line with the ultimately visible ceiling joints

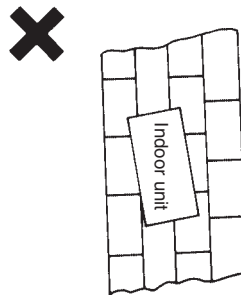
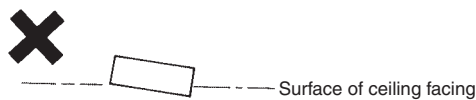
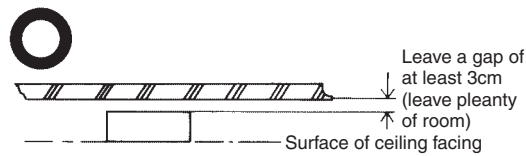

(V0961)

Important points

1. The suspension bolts must be strong enough to support the weight of the indoor unit.
2. Optional features must be added to the indoor unit prior to installation.
3. The model name should be checked prior to installation.
4. Take care to align the main unit correctly. (Bearing in mind piping layout and direction of blow out)
5. Leave sufficient space for servicing to be carried out.
6. Make inspection holes for model which need them.
7. Fit the unit to ensure proper drainage.

Example: Ceiling mounted cassette type (FXCQ63M)

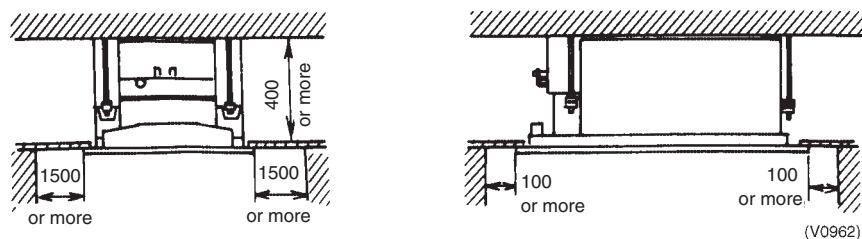

(V0962)

3.2.3 Refrigerant Pipe Work

■ Operational steps

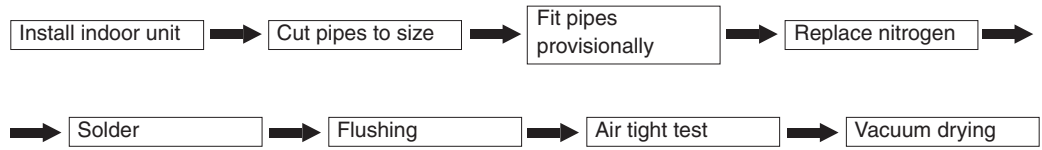

(V0963)

The 3 Principles of Refrigerant Piping

The “3 principles of refrigerant piping” must be strictly observed

	Cause of problem	Actoin to avoid problem
Dry	<ul style="list-style-type: none"> ● Rainwater, work water, etc. gets into pipes from outside ● Moisture generated inside pipes due to condensation 	
Clean	<ul style="list-style-type: none"> ● Formation of oxides inside pipes during soldering ● Dirt, dust or other extraneous material gets into pipes from outside 	
Air tight	<ul style="list-style-type: none"> ● Leak from soldered area ● Leak from flared area ● Leak from flange area 	

(V0964)

The 3 principles of refrigerant piping

Dry	Clean	Air tight
Make sure there is no moisture inside the pipes	Make sure there is no dirt inside the pipe	Make sure the refrigerant does not leak out
<p>(V0965)</p>	<p>(V1148)</p>	<p>(V1149)</p>

Method for Replacing Nitrogen (Brazing)

If brazing work is carried out without passing nitrogen gas through the pipes which are being brazed then this allows the formation of oxidation bubbles on the inside surface of the pipes. These oxidation bubbles are then carried along inside the pipes to cause damage to various members of the system such as valves or compressors and the system ceases to function properly.

In order to avoid this problem **nitrogen is passed through the pipes while the soldering work is being carried out**. This operation is known as nitrogen replacement. (Air is replaced by nitrogen)

This is **standard work practice for all brazing work**.

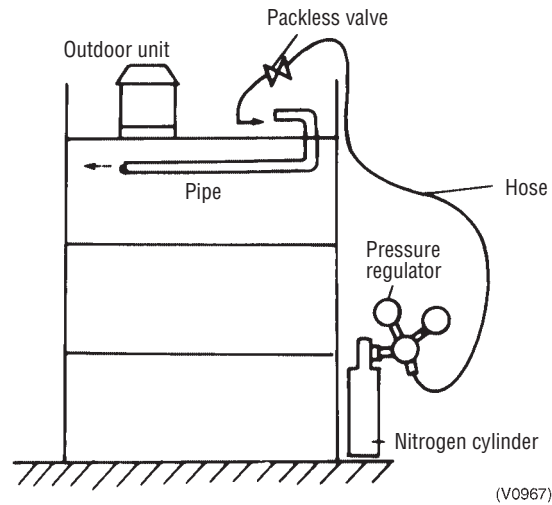
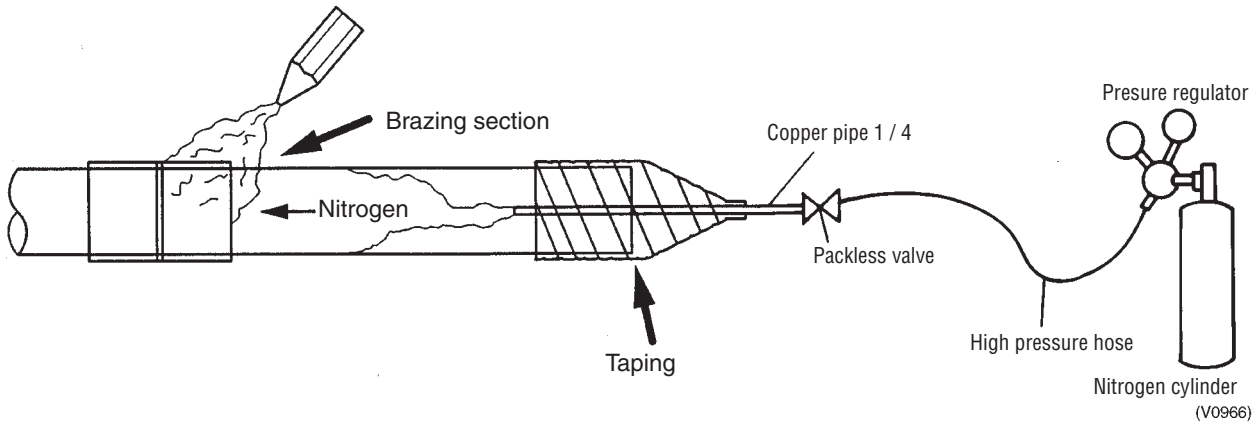

Important points:

1. The gas used must be nitrogen (oxygen, carbon dioxide and flon should not be used.)
2. A pressure regulator must be used.

Covering of Refrigerant Pipes

Covering is an extremely important operation as it prevents water, dirt or dust from getting inside the pipes. Moisture inside the pipes was a constant source of trouble in the past. The utmost care is required to nip this problem in the bud.

The end of each pieces of pipe must be covered. "Pinching" is the most effective method but "taping" is an simple alternative which may be used according to the work area and term of work.

Location	Term of Work	Covering Method
Outdoors	1 months or more	Pinching
	Less than 1 months	Pinching or taping
Indoors	Irrelevant	Pinching or taping

1. Pinching method
The end of the copper pipe is squeezed together and the gap brazed.
2. Taping method
The end of the copper pipe is covered with PVC tape (vinyl tape).

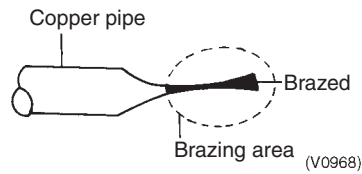

<Taping method>

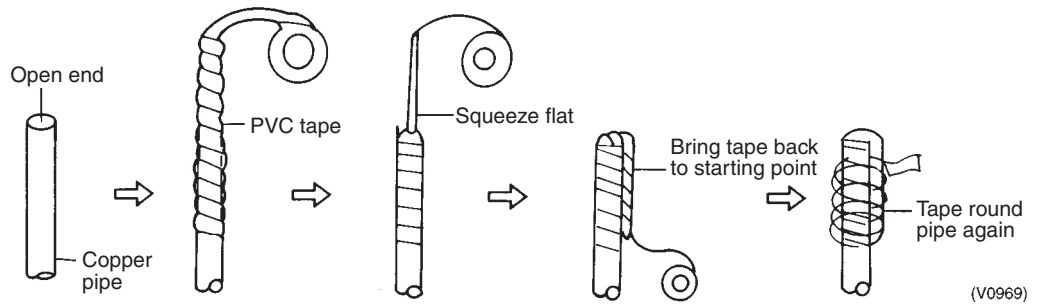

Particular care should be taken during the following operations:

- When passing copper pipe through a penetration hole (Dirt easily gets into the pipe).
- When copper pipe is located outside (Rainwater gets in)
(Special care is needed when the pipes are standing vertically outside).

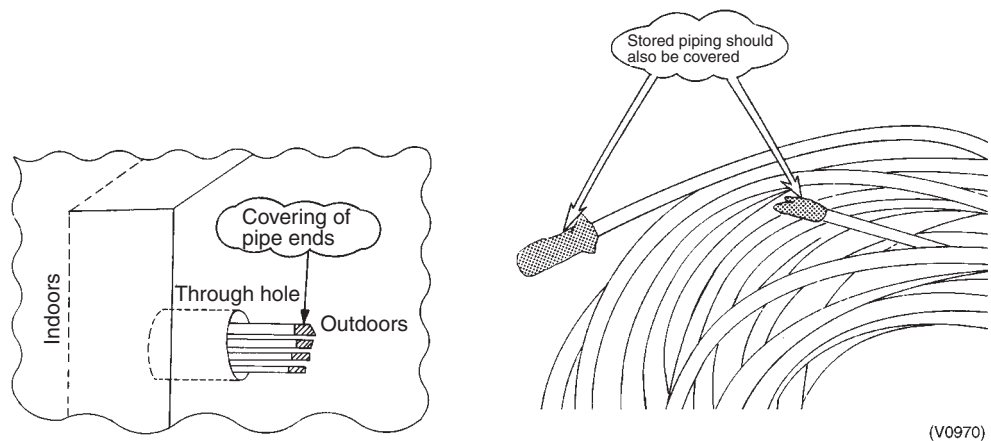

Refrigerant Pipe Flushing

Flushing is a method of cleaning extraneous matter out of pipes using pressurized gas.

[3 major effects]

1. Removal of oxidation bubbles formed inside copper pipes when “nitrogen replacement is insufficient” during soldering work
2. Removal of extraneous material and moisture from pipes when covering has been insufficient
3. Checks connections in pipes linking outdoor and indoor units (Both liquid and gas pipes)

[Example of procedure]

1. Set pressure regulator on nitrogen cylinder.
 *The gas used must be nitrogen.
 (There is a danger of condensation if fleon or carbon dioxide are used and oxygen carries the risk of explosions.)

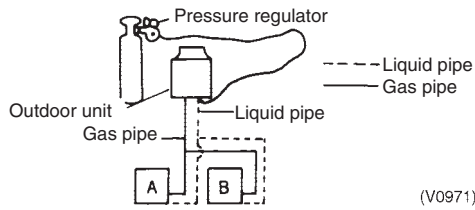

2. Connect the charge hose from the pressure regulator to the service port on the liquid pipe side of the outdoor unit.
3. Fit blanking plugs to all indoor units (B) other than unit A.

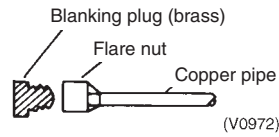

4. Open the main valve on the nitrogen cylinder and set the pressure regulator to 0.5MPa.

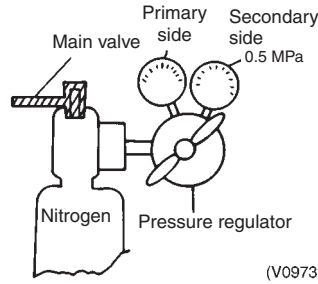

5. Check that the nitrogen is passing through the unit A liquid pipe.
6. Flushing.
 - Block the end of the pipe with the insulation of your hand.
 - ↓
 - When the gas pressure becomes too great to contain remove insulation quickly. (First flush)
 - ↓
 - Block the end of the pipe with insulation again.
 - ↓
 - (Carry out second flushing)

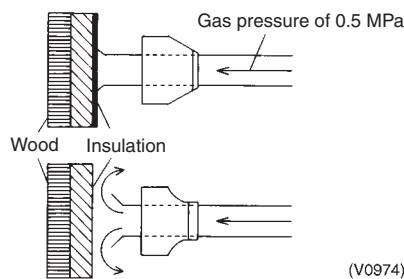

(The nature and amount of the extraneous material inside the pipe can be checked during flushing by placing a rag lightly over the end of the pipe. In the unlikely case that even a small quantity of moisture is found then the inside of the pipe should be dried out thoroughly.)

Action:

1. Flush the inside of the pipe with nitrogen gas. (Until such time as the moisture disappears.)
2. Carry out a thorough vacuum drying operation. (See page 39)
 - ① Close the main valve on the nitrogen cylinder.
 - ② Repeat the above operation for unit B.
 - ③ When the liquid pipe operations have been completed then do the same with the gas pipes.

Choice of Materials for Refrigerant Piping

a) Refrigerant piping



Selection of piping material

1. Foreign materials inside pipes (including oils for fabrication) must be 30mg/10m or less.
2. Use the following material specification for refrigerant piping:
 - construction material: Phosphoric acid deoxidized seamless copper for refrigerant.
 - size: Determine the proper size referring to chapter "Example of connection".
 - The wall thickness of the refrigerant piping should comply with relevant local and national regulations.
For R-410A the design pressure is 4.0 MPa.(40.8kgf/cm²).
3. Make sure to use the particular branches of piping that have been selected referring to chapter "Example of connection".
4. The piping minimum thickness and material.
 - * The min. thickness of the pipes shows the requirements of Japanese High Pressure Gas Control law. (As of Jan. 2003)
And the temper grade (○, 1/2H) shows the material type of JIS H 3300.
The thickness and material should comply with relevant local and national regulations for the design pressure 4.0MPa (40bar).
Select the wall thickness in accordance with relevant local and national regulations.

Size	R-410A	
	Temper grade	Minimum thickness (mm)
φ6.4	○	0.80
φ9.5	○	0.80
φ12.7	○	0.80
φ15.9	○	0.99
φ19.1	1/2H	0.80
φ22.2	1/2H	0.80
φ25.4	1/2H	0.88
φ28.6	1/2H	0.99
φ31.8	1/2H	1.10
φ34.9	1/2H	1.21
φ38.1	1/2H	1.32
φ41.3	1/2H	1.43

Equivalent piping length of joints and header (Reference)

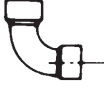
(Unit: mm)

Pipe Size	φ6.4	φ9.5	φ12.7	φ15.9	φ19.1	φ25.4	φ31.8	φ34.9	φ38.1	φ41.3
L Joints 	0.16	0.18	0.20	0.25	0.35	0.45	0.55	0.60	0.65	0.75
REFNET Joint 	0.5									
REFNET Header 	1.0									

b) Brazed joints and special branches







1. General use (L bend joint, socket joint, T joint, etc.)

- Joints must meet the requirements of the relevant JIS standard. (Size, materials, thickness, etc.)

2. Special branches

- The Daikin outdoor unit multi connection kit, REFNET joint, REFNET header or Reducing socket should be used.

Example: R-410A RXYQ-P Series

	REFNET joint	REFNET header	
		4 branches	8 branches
Liquid pipe (with heat insulation coating)			
Gas pipe (with heat insulation coating)			

(V0975)



Refer detail of DAIKIN REFNET joint and REFNET header on page 161.

c) Brazing

The Multi-System requires only copper/copper jointing and the jointing method is explained below.

- The use of “hard solder” is essential.

Type	Solder: JIS mark	Soldering: temperature (°C)	Breaking strength (kg/mm ²)	Soldering method	Jointing distance (mm)	Example for reference (product name)	Flux (example for reference)	Remarks
Hard solder	BCup-2 (Phospor copper solder)	735 ∩ 840	Approx. 25	Gas	0.05 ∩ 0.2	NEiS # 2BD	Not required	BCup-2 reacts easily with slufur to form a fragile water-soluble compound and should not therefore be used where the environment is not suitable.
	BAg-2 (Silver solder)	700 ∩ 845	Approx. 25	Gas	0.05 ∩ 0.2	NEiS # 107	NEiS # 103	Suitable for environments with a high sulfur content

This is used under normal conditions (V0976)

The R-410A Heat Pump, Cooling Only RX(Y)Q-P Series uses a wide range of piping sizes. You should therefore be careful when selecting the nozzle tip. If a small nozzle tip is used for brazing piping of large diameters such as φ38.1 and φ44.5, brazing flow becomes poor.

Table 1: Correlation of nozzle tip and size of refrigeration piping

Piping size	Nozzle tip No.							Brazing Rod diameter φ		
	# 200	# 225	# 250	# 315	# 400	# 450	# 500	1.6	2.4	3.2
6.4										
9.5										
12.7										
15.9										
19.1										
22.2										
25.4										
28.6										
31.8										
34.9										
38.1										
41.3										

(V0977)

Note: The values in the table above are for type B torch (French).

Brazing

- a) Brazing work should be carried out such that the final result is directed either downwards or sideways. An upward direction should be avoided wherever possible. (to prevent leakage)

<Recommended method>

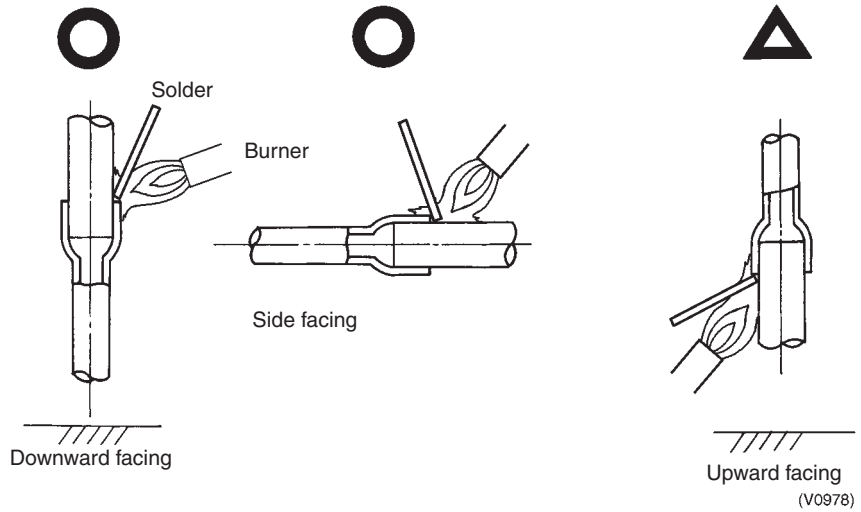

- b) Liquid and gas pipe branches should always be dealt with in the specified way with attention being paid to the direction of the fitting and its angle. (to prevent oil return or drift)
For example see page 200.
- c) It is standard working practice to use the nitrogen replacement method when brazing.

Important points

1. Every effort must be made to avoid fire. (Clean area where brazing is to be performed and make sure that fire fighting equipment and water are ready to hand.)
 2. Be careful of burns.
 3. Make sure that the gap between the pipe and the joint is correct. (To prevent leaks)
 4. Is the pipe adequately supported?
- As a rule the gaps between supports for horizontal piping (copper pipe) are as follows:

Copper pipe support spacing (From HASS 107-1977)

Nominal diameter	20 or less	25~40	50
Maximum gap (m)	1.0	1.5	2.0

- The copper pipe should not be secured directly by metal brackets.

Flare Connection

- (a) Stiffened pipe must always be annealed at least once prior to the flaring work.
- (b) A pipe cutter must be used to cut the pipe. (A large pipe cutter must be used where the pipe has a large diameter. When cutting a pipe which is too big for the pipe cutter a metal saw may be used but care must be taken to ensure that the debris from sawing does not get into the pipe.)
- (c) Set the flaring tool to make sure the flare size remains within the prescribed limits.

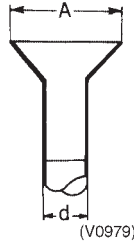

Nominal diameter	External diameter of pipe d	Pipe widening dimensions A
1/4	6.35	9.1
3/8	9.52	13.2
1/2	12.7	16.6
5/8	15.88	19.7
3/4	19.05	24.0

New Rank Compatible Flare Tool

Compared to previous refrigerants, the components of a HFC refrigerant is small. R-410A also has a higher pressure than other refrigerants. Therefore, in order to strengthen the intensity of the form and size of the flare section used for R-410A (class 2) apparatus, unlike the specification of the conventional refrigerants, it was set up with different standards. When carrying out flare processing, use a new rank compatible flare tool or a conventional flare tool.

Flare Gauge (Adapter Corresponding to the New Rank)

When using the later, use a flare gauge to take out the pipe from the gauge bar, adjust it, and then carry out the flare processing.



Size 12mmx72mm
Thickness 1.0x0.5mm Each

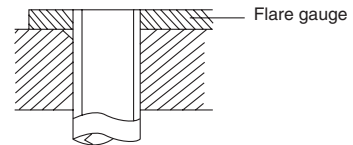

Size from the dice surface to the copper tip (in mm)

Name	Outer diameter	Wall thickness	Previous refrigerant (R-22, R-407C etc.)	R-410A
			The conventional flare tool	The conventional flare tool
			Clutch type	Clutch type
1/4"	6.35	0.8	0~0.5	1.0~1.5
3/8"	9.52	0.8	0~0.5	1.0~1.5
1/2"	12.70	0.8	0~0.5	1.0~1.5
5/8"	15.88	1.0	0~0.5	1.0~1.5

- (d) Coat the inner and outer surface of the flare with refrigerator oil (Ester or ether oil). (this ensures that the flare nut passes smoothly, preventing the pipe from twisting.)
Do not use SUNISO-4GS oil.

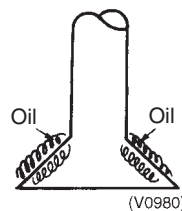

Important points

1. Burrs should be carefully removed.
2. 2 spanners should be used to grip the flare nuts.
3. The flare nut must be inserted before starting the flaring operation.
4. The appropriate amount of torque should be used to tighten the flare nut.

Standard torques for tightening flare nut	±10%
---	------

Size	Torque	
	(kgf-cm)	(N-cm)
1/4(6.4φ)	144~176	1420~1720
3/8(9.5φ)	333~407	3270~3990
1/2(12.7φ)	504~616	4950~6030
5/8(15.9φ)	630~770	6180~7540
3/4(19.1φ)	990~1210	9270~11860

5. Check that there is no superficial damage to the surface of the flare.

Flaring Procedure

- ① Cut the pipe using a pipe cutter.

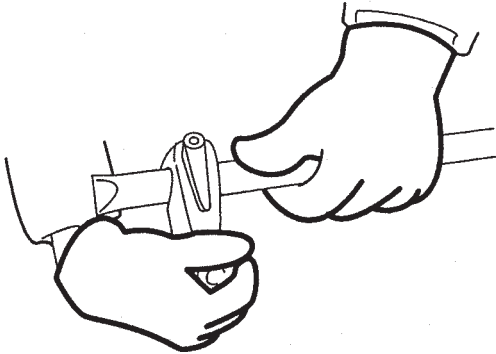

- ② The cut edge has burrs.
(The amount of burrs becomes larger when the pipe wall is thick)



- ③ Remove the burrs using a file.
(Be careful not to let particles enter the pipe. Point the pipe end downward during file)

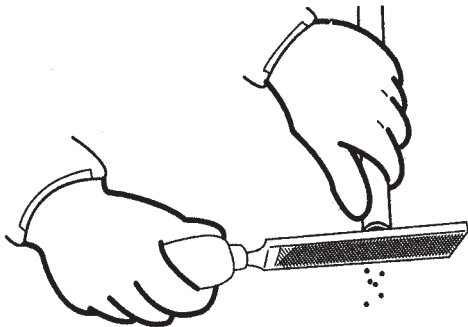

- ④ Remove the burrs using a reamer.
(Be careful not to let particles enter the pipe. Point the pipe end downward during cutting.)

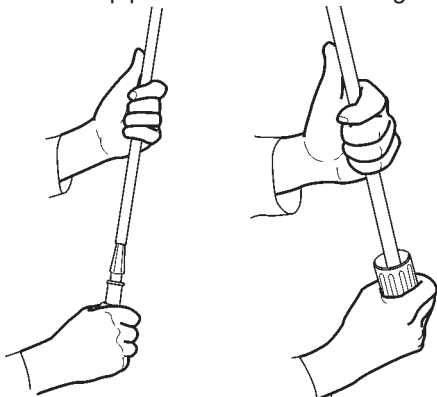

- ⑤ Clean the inside of the pipe.
(Use a thin stick with a cloth wrapped around it.)

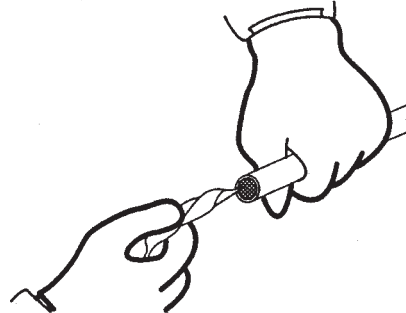

- ⑥ Before flaring, clean the cone section of the flaring tool.

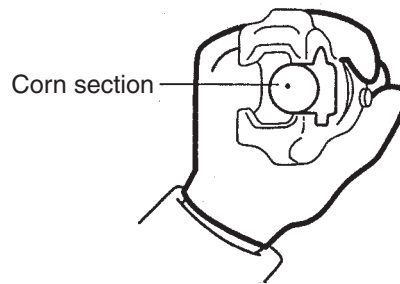

- ⑦ Flare the pipe.
Rotate the flaring tool 3 or 4 turns after a clicking sound is produced. This results in a clean flared surface.

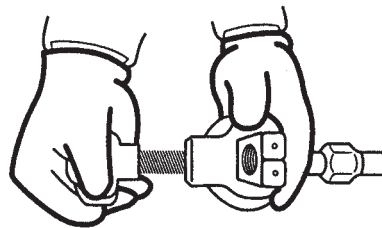

- ⑧ Apply refrigerant oil (Ester or ether oil) on the inside and outside of the flared section. (Do not apply SUNISO oil.)
(Be careful to keep dust away.)

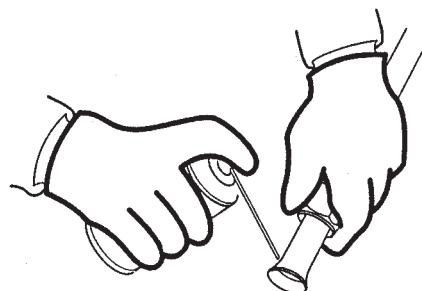

(V1352)

- ⑨ Tighten the flare nut.
(Use a torque wrench to apply the proper tightening force.)

- ⑩ Check for gas leaks.
(Check at the threaded section of the flare nut for gas leaks.)
Spray-type gas leak detecting products are available on the market. Soap water may be used to check for leaks, but use only neutral soap to prevent corrosion on the flare nut.
Be sure to wipe the nut area clean after the gas leak check.

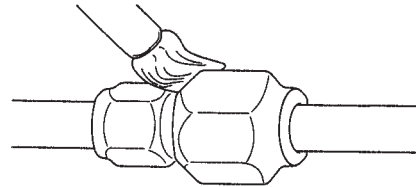
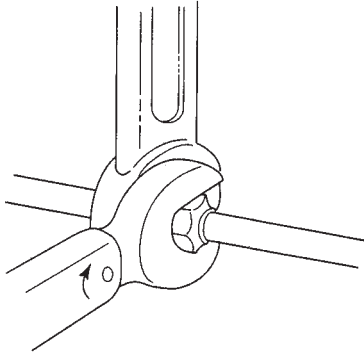

Tighten the flare but with proper torque.
It takes a lot of experience to tighten the flare nut properly without the use of a torque wrench.

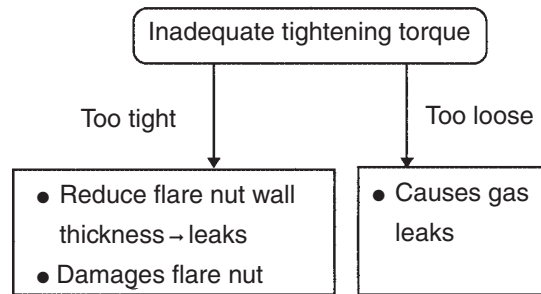

(V0984)

Not recommendable but in case of emergency

You must use a torque wrench but if you are obliged to install the unit without a torque wrench, you may follow the installation method mentioned below.

After the work is finished, make sure to check that is no gas leak.

When you keep on tightening the flare nut with a spanner, there is a point where the tightening torque suddenly increases. From that position, further tighten the flare nut the angle shown below:

Pipe size	Further tightening angle	Recommended arm length of tool
6.4 (1/4")	60 to 90 degrees	Approx. 150mm
9.5 (3/8")	60 to 90 degrees	Approx. 200mm
12.7 (1/2")	30 to 60 degrees	Approx. 250mm
15.9 (5/8")	30 to 60 degrees	Approx. 300mm
19.1 (3/4")	20 to 35 degrees	Approx. 450mm

Flange Connection

- a) The flange sheet surface should be clean and undamaged. (Clean any dirt away with a cloth and check that there has been no damage.)
- b) Coat the flange sheet surface with refrigeration oil (Ester or ether oil) and then insert the packing. (Do not use SUNISO oil.)

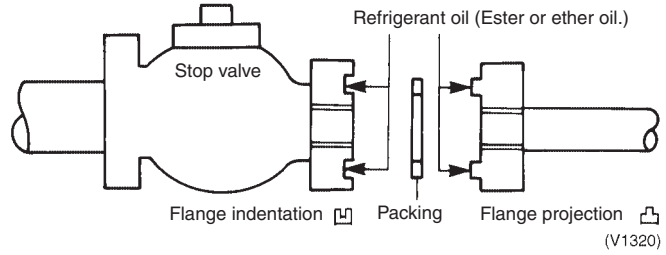

- c) Tighten the bolts in opposite corners first to ensure that the connection is true.

[Example]

Order: A→C→B→D

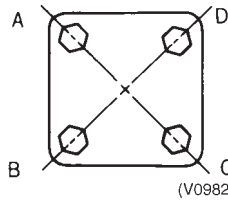

The bolts should be tightened little by little in the above order such that the same degree of torque is applied evenly to each corner.

Important points

- 1. Only clean refrigeration/oil should be used to coat the flange. (i.e. free from dirt or water)
- 2. The correct amount of torque should be applied when tightening the flange bolts.

Standard torques for tightening screws and bolts

ISO hexagonal bolt

Size	Class	5.8(5T)		10.9(10T)	
		kgf-cm ±15%	N-m ±15%	kgf-cm ±15%	N-m ±15%
M8		125	1230	302	2960
M10		257	2520	620	6080
M12		436	4280	1,050	10,300
M16		1,030	10,100	2,480	24,300
M20		2,050	20,100	4,950	48,500

3.2.4 Thermal Insulation Work (Refrigerant Piping)

■ Operational steps



(V0985)

Materials

The thermal insulation materials which are used must be well able to withstand the heat from the pipes.

Example:

Heat pump type: Heat resistant polyethylene foam (heat resistance of at least 120°C)

Cooling only: Polyethylene foam (heat resistance of 100°C or more)

Essential Points of Thermal Insulation

The insulation of jointed areas such as the soldered, flared or flanged sections should only be carried out after the successful completion of the air tight test.

The tips for insulation

- Gas piping must be insulated.
- Be sure to insulate the liquid-side and gas-side piping for the inter-unit piping and the refrigerant branch kits and always use 18-type or better insulation for the oil pressure equalizer.
- Materials: Glass fiber or heat resistant polyethylene foam.
Thickness: 10mm or more
Heat resistance: Gas pipe : 120°C or more / Liquid pipe : 70°C or more
- If you think the humidity around the cooling piping might exceed 30°C and RH80%, reinforce the insulation on the cooling piping (at least 20mm thick). Condensation might form on the surface of the insulation.
- Insulation of both liquid and gas pipe

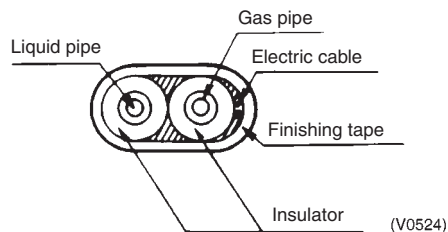

Caution

Be sure to size up the main gas line in the connecting piping of the suction gas piping if the equivalent length of the piping between the indoor and outdoor units exceeds 90m. In order to minimize the reduction of capacity caused by the pressure drop, the refrigerant pipe size may be sized up.

3.2.5 Air Tight Test

■ **Operational steps**

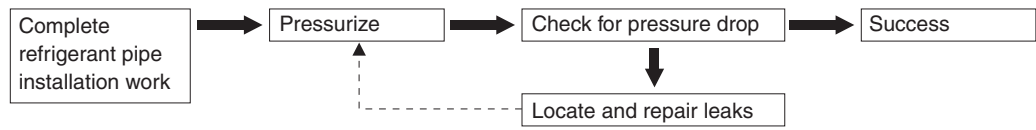

(V0987)

Essential Points of Testing (Maintaining Pressure Over a Period)

The key to successful testing is strict adherence to the following procedure:

a) The liquid and gas piping in each refrigerant system should be pressurized in turn in accordance with the following steps. (Nitrogen gas must be used.)

- **Step 1: increase pressure to 0.3MPa for 3 minutes or more**
 - **Step 2: increase pressure to 1.5MPa for 3 minutes or more**
 - **Step 3: increase pressure to 4.00MPa for approx. 24 hours**
- } Indicates existence of major leaks
- } Indicates existence of minor leaks

* Increasing the system pressure to 4.00MPa does not guarantee the identification of minor leaks if pressure is maintained for only a short time. It is therefore recommended that the system remain pressurized in accordance with Step 3 above for at least 24 hours.



Note: The pressure must on no account be increased beyond 4.00MPa.

- b) Check for pressure drop

If there is no drop in pressure then the test is deemed a success.

If the pressure drops then the leak must be located. See following page.

However, if there is a change in the ambient temperature between the pressurizing stage and the time when you check for a drop in pressure then you will have to adjust your calculations accordingly since a change of 1°C can account for a pressure change of approximately 0.01MPa.

Compensating adjustment value:

(temperature at time of pressurizing – temperature at time of checking) × 0.01

Example:

Time of pressurizing: 4.00MPa 25°C

24 hours later: 3.95MPa 20°C

The pressure drop in such a case is deemed to be zero (successful test).

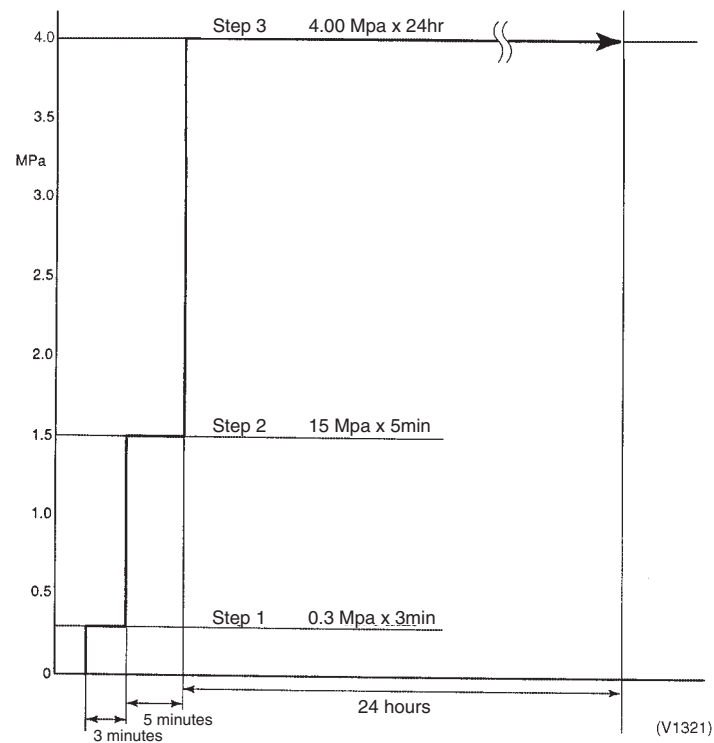

Checking for Leaks

[Check 1] (Where pressure falls while carrying out Steps 1 to 3 described on previous page)

- Check by ear.....Listen for the sound of a major leak.
- Check by hand.....Check for leak by feeling around jointed sections with hand.
- Soap and water check (*Snoop).....Bubbles will reveal the presence of a leak.

[Check 2] (When searching for a minor leak or when there has been a fall in pressure while the system has been fully pressurized but the source of the leak cannot be traced.)

1. Release the nitrogen until the pressure reaches 0.3MPa.
2. Increase pressure to 1.5MPa using gaseous flon gas (R-410A). (Nitrogen and flon gas mixed)
3. Search for the source of the leak using a leak detector.
4. If the source of the leak still cannot be traced then repressurize with nitrogen up to 4.00MPa and check again. (The pressure must not be increased to more than 4.00MPa.)

Setup of Air-tight Test

- Referring to following figure, connect an nitrogen tank, refrigerant tank, and a vacuum pump to the outdoor unit.
- The shutoff valve and valve A~C in following figure should be open or closed as shown in the table below.

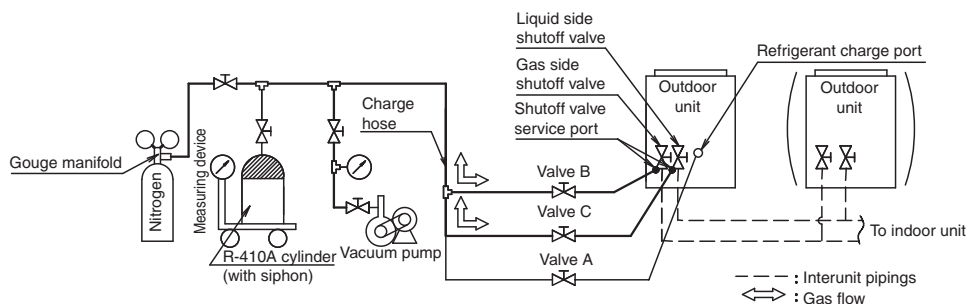

■ Important points

1. Where the lengths of piping involved are particularly long then the air tight test should be carried out block by block.

Example:

1. Indoor side
2. Indoor side + vertical pipes
3. Indoor side + vertical pipes + outdoor side

3.2.6 Vacuum Drying

What is vacuum drying?

Vacuum drying is:

“The use of a vacuum pump to vaporize (gasify) the moisture (liquid) inside the pipes and expel it leaving the pipes completely dry inside.”

At 1 atm (760 mmHg) the boiling point (evaporating temperature) of water is 100°C but if a vacuum is created inside the pipes using a vacuum pump then the boiling point is rapidly reduced as the degree of the vacuum is increased. If the boiling point is reduced to a level below that of the ambient temperature then the moisture in the pipes will evaporate.

Boiling point of water (°C)	Pressure		
	*mmHg	Pa	Torr
40	-705	7333	55
30	-724	4800	36
26.7	-735	3333	25
24.4	-738	3066	22
22.2	-740	2666	20
20.6	-742	2400	18
17.8	-745	2000	15
15.0	-747	1733	13
11.7	-750	1333	10
7.2	-752	1066	8
0	-755	667	5

<Example>
 When outside temperature is 7.2°C
 As shown in the table on the right, the degree of vacuum must be lowered below -752mmHg.



Above figures (mmHg) are gauge pressure readings.

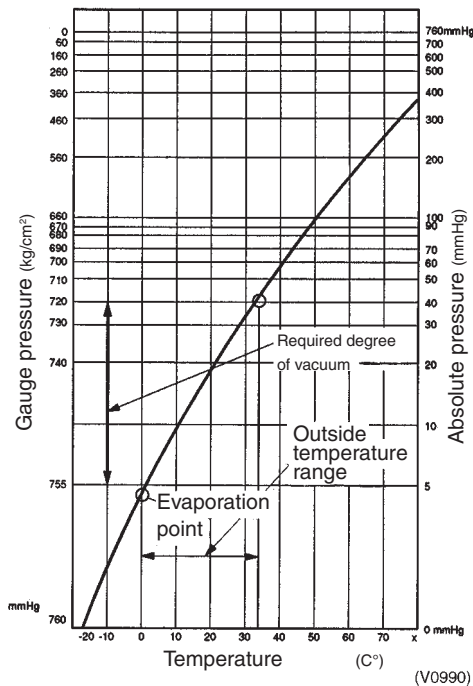

The evacuation of air conditioner piping provides the following effects.

1. Vacuum drying
2. Removes air and nitrogen (used in air-tightness test) from the inside of pipes.

Therefore, it is necessary to ensure that the both purposes have been achieved in the vacuum drying operation.

Key points
Lower the degree of vacuum to below -755mmHg

(V1216)

Choosing a Vacuum Pump

General

Refrigerant piping content volume of the VRV III R-410A Series is larger than the VRV Inverter Series, and consequently takes more time for vacuum drying. If you have time to spare, you may use the same vacuum pump, but if you want to save time, you will have to use a pump with higher exhaust velocity (exhaust volume).

The Necessity for Counter Flow Prevention

After the vacuum process of the refrigerant cycle, the inside of the hose will be vacuumed after stopping the vacuum pump, and the vacuum pump oil may flow back. Moreover, if the vacuum pump stops during the operation by some reason, the same thing happens.

In such cases, different oil mixes in the HFC system refrigerant apparatus cycle, and becomes the cause of a refrigerant circuit trouble. Therefore, in order to prevent the counter flow from the vacuum pump, a check valve is needed.

Vacuum pump with check valve or vacuum pump adapter

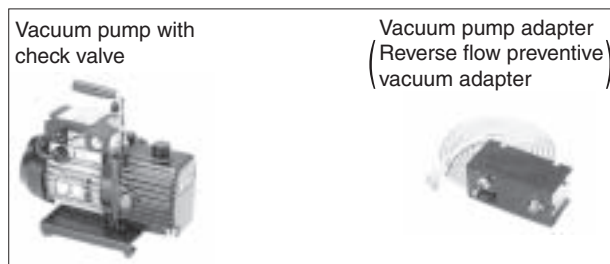

1. Vacuum pump performance

The 2 most important things for determining vacuum pump performance are as follows:

- (1) Exhaust velocity
- (2) Degree of vacuum

(1) Exhaust velocity

Exhaust volume is usually expressed as l/min or m³/h. The larger the number, the faster vacuum is achieved.

Generally speaking, the faster the exhaust velocity, the larger and heavier the vacuum pump itself is.

Commercially available vacuum pumps (exhaust velocity of 20 - 30 l/min) usually take an extremely long time to achieve vacuum. (We recommend a vacuum pump of approx. 60 - 100 l/min.)

(2) Degree of vacuum

Ultimate vacuum varies largely according to use of the vacuum pump. Vacuum pumps used for vacuum forming cannot be used for vacuum drying. (A vacuum pump with a high degree of vacuum is required.)

When selecting a vacuum, you should select one which is capable of achieving 0.2 Torr of ultimate vacuum.

Degree of vacuum is expressed in Torr, micron, mmHg, and Pascal (Pa). The units correlate as follows:

	Unit	Standard atmospheric pressure	Perfect vacuum
Gauge Pressure	kg/cm2	0	-1.033
Absolute Pressure	kg/cm2 abs	1.033	0
Torr	Torr	760	0
Micron	Micron	760000	0
*mmHg	mmHg	0	760
Pa	hPa	1013.33	0

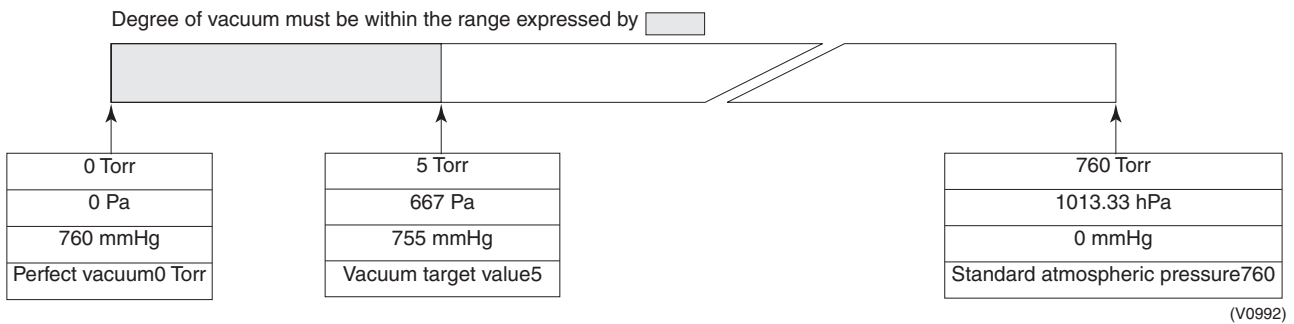

2. Vacuum pump maintenance

Because of their nature, most vacuum pumps contain large amounts of oil which lubricates bearings, etc., and functions to enhance airtightness of pistons. When using a vacuum pump to discharge air from refrigerant piping, moisture in the air tends to get mixed in with the oil. You must therefore change oil periodically and make sure the proper oil level is maintained. (Perform periodic inspections in accordance with the operating instructions.)

3. Degree of vacuum measurement

An extremely accurate vacuum gauge is required to test degree of vacuum. You cannot accurately measure degree of vacuum with the compound gauge on the gauge manifold. A Pirani vacuum gauge is required to measure degree of vacuum accurately. Because Pirani gauges are very sensitive and require extreme care when using, they are not very suitable for use in the field. You should therefore use the Pirani gauge to calibrate the attached vacuum gauge on the gauge manifold and the degree of vacuum of the vacuum pump.

4. Calibration method

1. Connect a Pirani vacuum gauge and the gauge manifold vacuum gauge (0 - 760 mmHg) to the vacuum pump at the same time, and run the pump for about 3 minutes.
2. Make sure the reading of the Pirani vacuum gauge is 5 Torr (667 Pa) or less. The reading of conventional vacuum pumps lowers to about 0.2 Torr.
If the reading is not 5 Torr or less, check the vacuum pump oil. (Oil is low in many cases.)
3. Check the attached gauge on the gauge manifold. Adjust the gauge if the reading is not exactly correct.
4. Adjust the gauge manifold valve so that the Pirani vacuum gauge reads 5 Torr.
5. Mark the position indicated by the gauge manifold gauge with an oil based ink pen.
6. Use the mark of the gauge manifold as a target when vacuuming in the field.

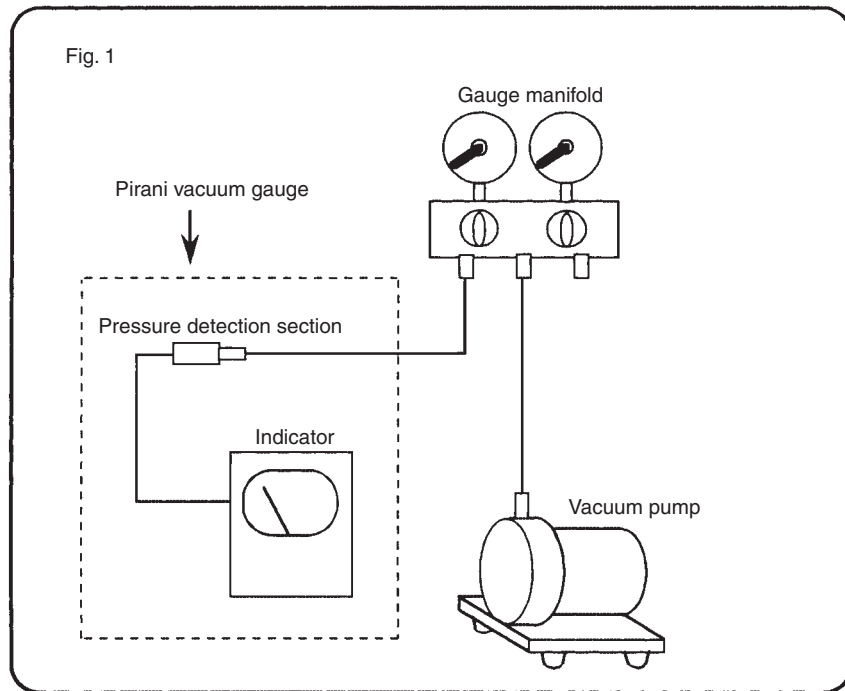

(V0993)

(Reference) Types of vacuum pump with respective maximum degree of vacuum

Type	Maximum Degree of Vacuum		Use	
		Expulsion Capacity	Vacuum Drying	Air Expulsion
Oil Rotary (Oil Using)	0.02 mmHg	100 l/min	Suitable	Suitable
Oilless Rotary (No Need of Oil)	10 mmHg	50 l/min	Unsuitable	Suitable
	0.02 mmHg	40 l/min	Suitable	Suitable

← Many handy pumps fall into this category

Vacuum Drying Procedure

There are two vacuum drying methods and the appropriate one should always be chosen to conform with individual local conditions.

[Normal vacuum drying].....The standard method

[Operational steps]

1. Vacuum drying (1st time): Connect a manifold gauge to the service port of the liquid or gas pipe and operate the vacuum pump for at least 2 hours.
(The degree of vacuum produced should be in excess of -755 mmHg)
 If after 2 hours the vacuum produced has not exceeded 5 mmHg then either there is moisture in the pipe or there is a leak. Operate the vacuum pump for a further hour.
 If, even after 3 hours, the vacuum has not reached -755 mmHg then check the system for a leak.
2. Carry out maintained vacuum test.
 Produce a vacuum in excess of -755 mmHg and do not release it for an hour or more. Check the vacuum gauge to make sure that it has not risen. (If the gauge does rise then there is still moisture in the pipe or there is a leak somewhere.)
3. Additional charge of refrigerant.
 Connect the charging cylinder to the liquid pipe service port and charge with the required amount of refrigerant.
4. Open stop valve to the full.
 Open the stop valves on the liquid and the gas pipes to the full.



Note: Vacuums should be produced in both the liquid and the gas pipes.
 (Because there are a large number of functional components in the indoor unit which cut off the vacuum mid-way through)

[Standard vacuum drying time chart]

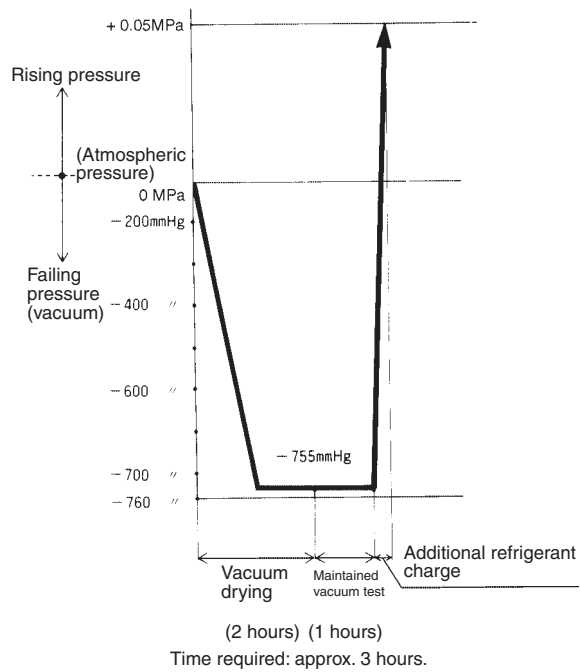

(V0991)

Special vacuum drying

This vacuum drying method is selected when there is a suspicion that there may be moisture in the pipes.

For example:

- When moisture was discovered during the refrigerant pipe flushing operation
- When there is a risk of condensation forming inside the pipes during periods of heavy rainfall
- When there is a risk of condensation forming inside the pipes if this refrigerant pipe works takes long time
- When there is a risk that rainwater may have entered the pipes during installation

The special vacuum drying method is the same as the standard method except that nitrogen is introduced into the pipes to break the vacuum on one or more occasions during the course of the operation.

[Operational steps]

1. Vacuum drying (1st time): 2 hours
 2. Vacuum breaking (1st time): Use nitrogen to raise pressure to +0.05MPa.
(Since the nitrogen gas used to break the vacuum is dry nitrogen this process serves only to enhance the overall drying effect of the vacuum drying operation itself.
However, since the effectiveness of this process is severely impaired by a high moisture level inside the pipes, the utmost care is required during installation to see that water does not enter or form inside the refrigerant pipes.)
 3. Vacuum drying (2nd time): Operate the vacuum pump for at least 1 hour.
(Observations: Degree of vacuum has reached -755 mmHg. If the degree of vacuum has not reached -755 mmHg after 2 hours or more then repeat the operations at 2 (vacuum breaking) and 3 (vacuum drying) above.)
 4. Carry out maintained vacuum test: 1 hour
 5. Additional charge of refrigerant
 6. Open stop valve to the full
- * The gas used for the vacuum breaking operation must be nitrogen.
(The use of oxygen brings a serious risk of explosions)

[Special vacuum drying time chart]

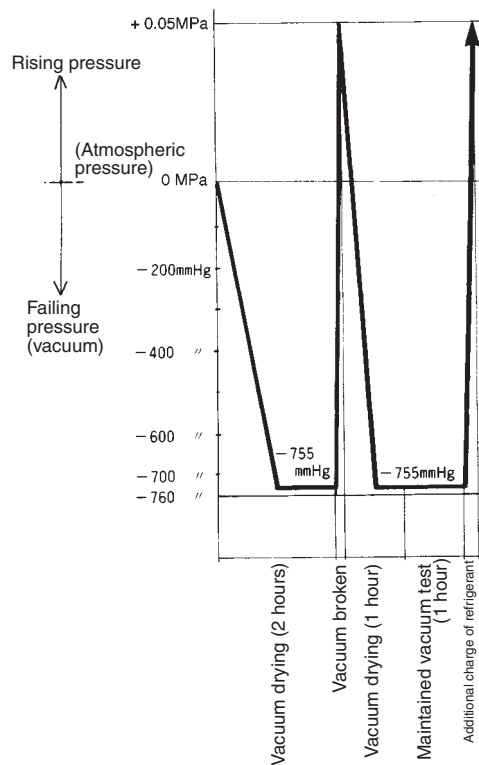

Time required: approx. 4 hours.

(V0994)

3.2.7 Additional Charge of Refrigerant at installation time

■ Operational steps

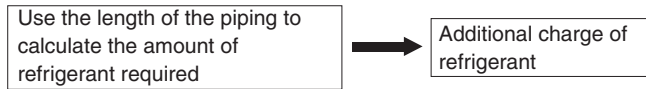

(V0995)

Important points

1. The results of all calculations must be recorded. (Make a list.)
2. The refrigerant will need to be additionally charged whenever the distance between the outdoor unit and the most distant indoor unit is more than 10m.
3. The additional charging operation should be carried out by input of liquid from Service port at liquid stop valve following completion of the vacuum drying operation.
4. When the additional charging operation cannot be satisfactorily completed use the action of the compressor to complete the additional charging during the test run.

Refrigerant Charging Instructions

HFC401A are Quasi-azeotropic* refrigerants. Therefore, these refrigerants must be charged in the liquid state. When charging the refrigerant into equipment from the refrigerant cylinder, turn the refrigerant cylinder upside down.

Important: Make sure that the refrigerant (liquid) is taken out from the bottom part of the refrigerant cylinder. Do not take out the refrigerant (gas) at the upper part of the refrigerant cylinder for charging.

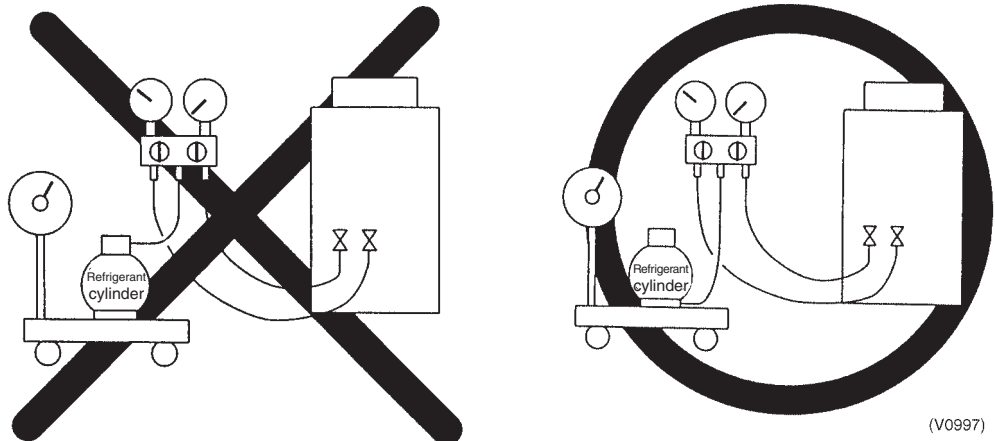

(V0996)

(V0997)



Caution

Since some refrigerant cylinders differ in the internal mechanism, it is necessary to examine the cylinder carefully. (Some cylinders have a siphon tube to eliminate the need for turning it upside down.)

Siphon tube

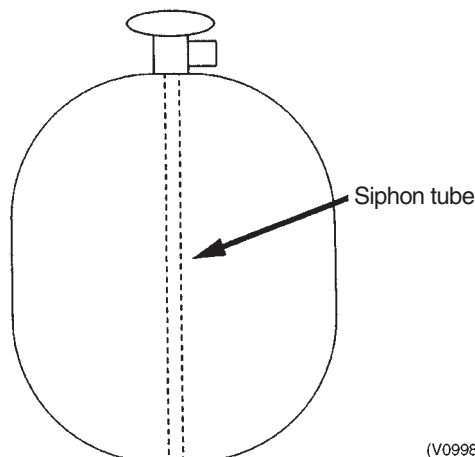

(V0998)

<*Non-azeotropic refrigerants or Quasi-azeotropic refrigerants>

When a refrigerant is a mixture of two or more types with different evaporation temperature, it is called a non-azeotropic refrigerant. If all refrigerant components evaporate at the same temperature, the mixture is called an azeotropic refrigerant.

If a non-azeotropic refrigerant is charged into equipment in the gaseous state, the refrigerant components that evaporate sooner than others enter the equipment, and the refrigerant that evaporate after others remain in the refrigerant cylinder.

* Quasi-azeotropic mixture refrigerant: mixture of two or more refrigerants having similar boiling points.

Caution items

The following devices designed for R-22 cannot be used to charge the new refrigerants. Be sure to use the devices specifically designed for the new refrigerants.

1. Charging cylinder...(Pressure resisting specification is different.)
2. Gauge manifold (including hose)...(same as above)

3.2.8 Drain Pipe Work (Indoor)

■ Operational steps

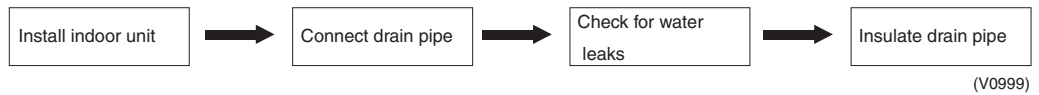

Drain Pipe Gradient and Support

- a) The drain pipe must be fitted at a gradient of at least 1/100. The drain pipe should be as short as possible and free from airlocks.

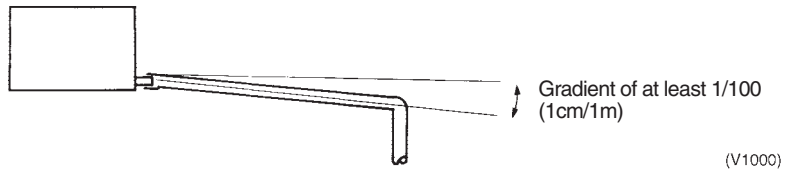

- b) Suspension bolts should be used to support long stretches of drain pipe in order to ensure that a gradient of 1/100 is maintained. (PVC pipes should not be bent)

Spacing of supports for horizontal piping

Class	Nominal diameter	Spacing
Rigid PVC pipe	25~40mm	1~1.5m

- c) The length of pipe laid horizontally should be kept to a minimum.

Drain Trap

Fit any indoor unit whose drain pipe connection is subjected to negative pressure, with a drain trap. (FXYMP40~125 only)

- a) Rig the drain trap as shown in the drawing below.

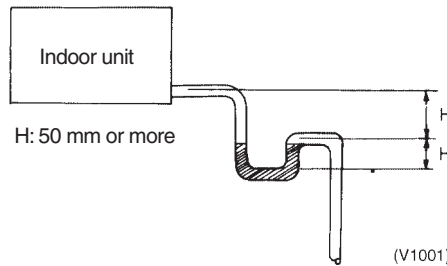

- b) Provide one trap per unit. A single trap for converging units will prove ineffective.
- c) Rig the trap to allow for future cleaning.

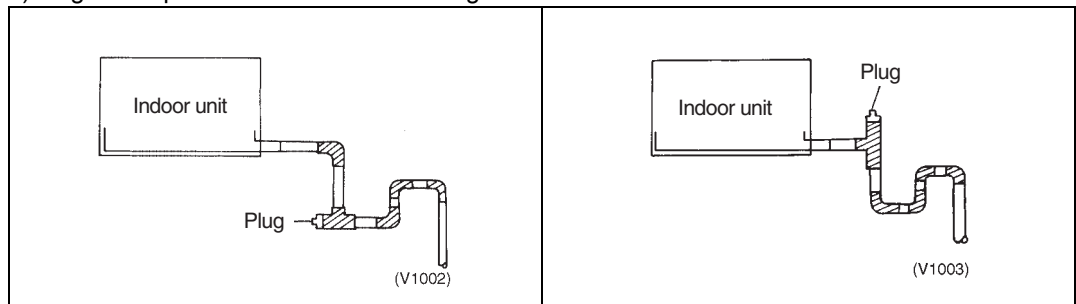

Grouped Drain Piping

1. It is standard work practice to make connections to the main pipe from above. The pipe down from the combination should be as large as possible.

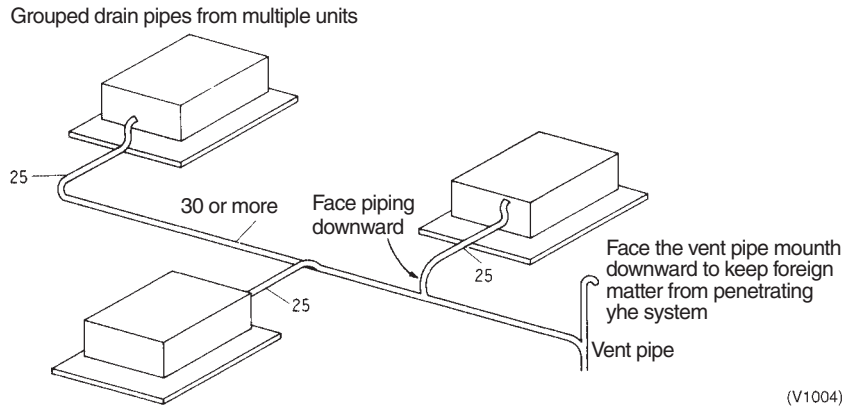

2. The pipework should be kept as short as possible and the number of indoor units per group kept to a minimum.

Use of an Auxiliary Drain Hose (Flexible)

If a drain pan made of polystyrene foam is used then an auxiliary drain hose (flexible) is also essential. A flexible drain hose permits the drain socket and drain pipe to be connected without difficulty and prevents any undue strain being placed on the drain pan.

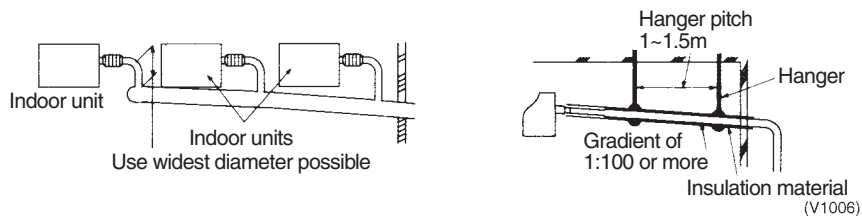
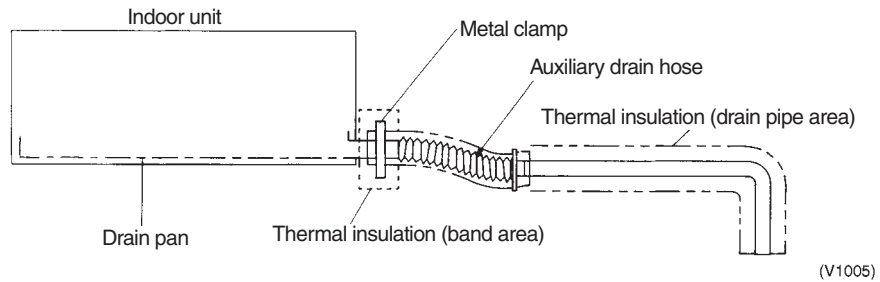

Important points

1. The drain pipe should be at least equal in size to that of the indoor unit.
2. The drain pipe is thermally insulated to prevent the formation of condensation inside the pipe.
3. The drain up mechanism should be fitted before the indoor unit is installed and when the electricity has been connected some water should be added to the drain pan and the drain pump checked to see that it is functioning correctly.
4. All connections should be secure. (Special care is needed with PVC pipe)
The use of a colored adhesive with PVC pipes will help you to remember to connect them up.)

Piping Diameter for Grouped Drain Pipes

- Select piping diameter from the below table in accordance with the amount of condensation drained by all units with a common drain pipe.
- Consider 2 l/hr of drainage for every 1 HP. For example, drainage from 3 units running at 2 HP and 2 units running at 3 HP is calculated as follows.
 $2 \text{ (l/hr)} \times 2 \text{ (HP)} \times 3 \text{ (units)} + \{ 2 \text{ (l/hr)} \times 3 \text{ (HP)} \times 2 \text{ (units)} = 24 \text{ l/hr}$

1. Relationship between horizontal pipe diameter and allowable drainage (for extended ventilation system)

JIS nominal	Vinyl chloride pipe diameter (mm)	Allowable flow rate (l/hr)		Remarks
		Piping gradient 1:50	Piping gradient 1:100	
VP20	20	39	27	(Reference value) Cannot be used in grouped piping.
VP25	25	70	50	
VP30	31	125	88	Can be used in grouped piping.
VP40	40	247	175	
VP50	51	473	334	



Notes:

- Calculations have been made with water area inside the pipe as 10%.
- Allowable flow rate figures below the decimal have been discarded.
- Use VP30 or larger pipe after the convergence point.

2. Relationship between riser diameter and allowable drainage (for extended ventilation system)

JIS nominal	Vinyl chloride pipe diameter (mm)	Allowable flow rate (l/hr)	Remarks
VP20	20	220	(Reference value) Cannot be used in grouped piping.
VP25	25	410	
VP30	31	730	Can be used in grouped piping.
VP40	40	1440	
VP50	51	2760	
VP65	67	5710	
VP75	77	8280	



Notes:

- Allowed flow rate figures below the decimal have been discarded.
- Use VP30 or larger pipe in risers.
- Use the same drain pipe for the humidifier as the indoor unit.

3.2.9 Drain Piping for Each Model

Ceiling Mounted Cassette Type (FXCQ-M Double flow)

Drain Pump Kit

Indoor unit	Drain pump kit
FXCQ-M	Standard (Equipped with indoor unit)

Drain Piping Work

⟨⟨Rig the drain pipe as shown below and take measures against condensation. Improperly rigged piping could lead to leaks and eventually wet furniture and belongings.⟩⟩

(1) Carry out the drain piping

- The diameter of the drain pipe should be greater than or equal to the diameter of the connecting pipe (vinyl tube, pipe size: 25 mm; outer dimension: 32 mm).
- Keep the drain pipe short and sloping downwards at a gradient of at least 1/100 to prevent air pockets from forming.
- If the drain hose cannot be sufficiently set on a slope, execute the drain raising piping.
- To keep the drain hose from sagging, space hanging wires every 1 to 1.5 m.

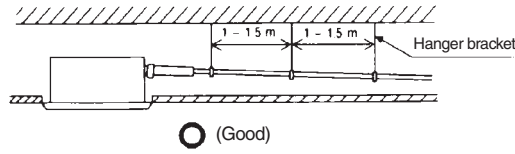

(V0615)

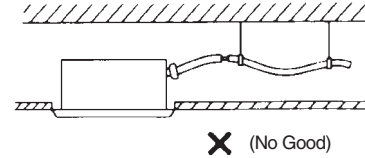

(V0616)



Caution

Setting the unit at an angle opposite to the drain piping might cause leaks.

- Use the attached drain hose and clamp metal.
Insert the drain hose into the drain socket, up to the white tape. Tighten the clamp until the screw head is less than 4mm from the hose.
- Wrap the attached sealing pad over the clamp and drain hose to insulate.
- Insulate the drain hose inside the building.

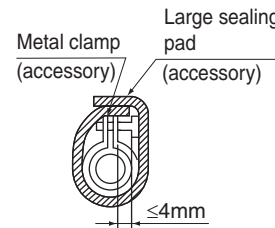
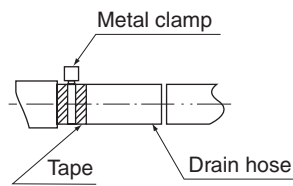

(PRECAUTIONS FOR DRAIN RAISING PIPING)

- Install the drain raising pipes at a height of less than 310 mm.
- Install the drain raising pipes at a right angle to the indoor unit and no more than 300 mm from the unit.

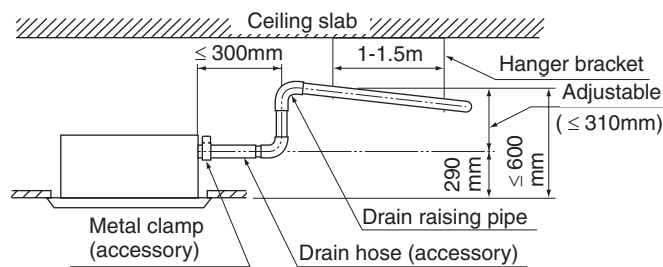

- If converging multiple drain pipes, install according to the procedure shown below.

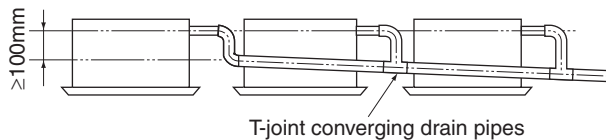

Select converging drain pipes whose gauge is suitable for the operating capacity of the unit.



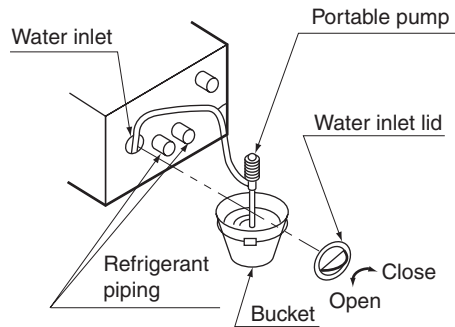

(2) After piping work is finished, check drainage flows smoothly.

- Open the water inlet lid, add approximately 2.5 liter of water gradually and check drainage flow.

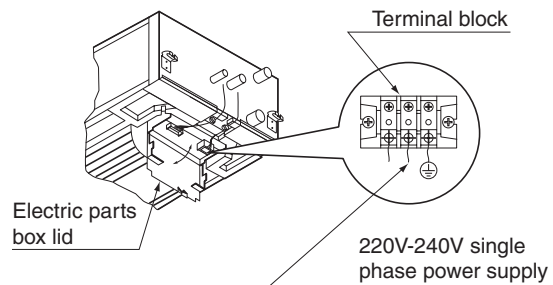
**WHEN ELECTRIC WIRING WORK IS FINISHED**

- Check drainage flow during COOL running, explained under "TEST OPERATION".

WHEN ELECTRIC WIRING WORK IS NOT FINISHED

- Remove the electric parts box lid, connect a power supply and remote control to the terminals.
(Refer to the "HOW TO CONNECT WIRINGS")
Be sure attach the electric parts box lid before turning on the power.
- Next, press the inspection / test operation button "  " on the remote control. The unit will engage the test operation mode. Press the operation mode selector button "  " until selecting FAN OPERATION "  ". Then, press the ON / OFF button "  ". The indoor unit fan and drain pump will start up. Check that the water has drained from the unit. Press "  " to go back to the first mode.
- **Be careful when doing so because the fan is turning at the same time.**
- Attach the electric parts box lid as before.

**Caution**

- Drain piping connections
Do not connect the drain piping directly to sewage pipes that smell of ammonia. The ammonia in the sewage might enter the indoor unit through the drain pipes and corrode the heat exchanger.
- Keep in mind that it will become the cause of getting drain pipe blocked if water collects on drain pipe.

3PR01906-7R

**Ceiling Mounted
Cassette Type
(FXFQ-M Multi-
flow)**

Drain Pump Kit

Indoor unit	Drain pump kit
FXFQ-M	Standard (Equipped with indoor unit)

Drain Piping Work

(1) Carry out the drain piping

- Lay pipes so as to ensure that drainage can occur with no problems.
- Employ a pipe with either the same diameter or with the diameter larger (excluding the raising section) than that of the connecting pipe (PVC pipe, nominal diameter 25 mm, outside diameter 32 mm).
- Keep the drain pipe short and sloping downwards at a gradient of at least 1/100 to prevent air pockets from forming.
- If the drain hose cannot be sufficiently set on a slope, execute the drain raising piping.
- To keep the drain hose from sagging, space hanging wires every 1 to 1.5 m.

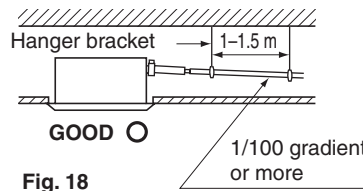

Fig. 18

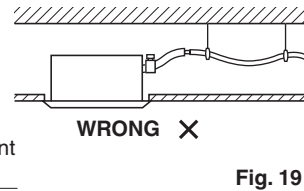

Fig. 19

- Use the attached drain hose (1) and clamp (2).
- Insert the drain hose into the drain socket up to the base, and tighten the clamp securely within the portion of a white tape of the hose-inserted tip. Tighten the clamp until the screw head is less than 4 mm from the hose.
- Wrap the attached sealing pad (10) over the clamp and drain hose to insulate.
- Make sure that heat insulation work is executed on the following 2 spots to prevent any possible water leakage due to dew condensation.
 - Indoor drain pipe
 - Drain socket

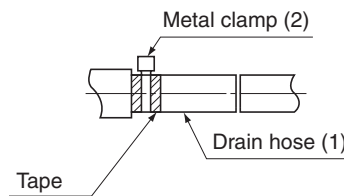

Fig. 20

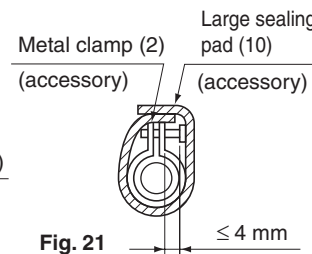
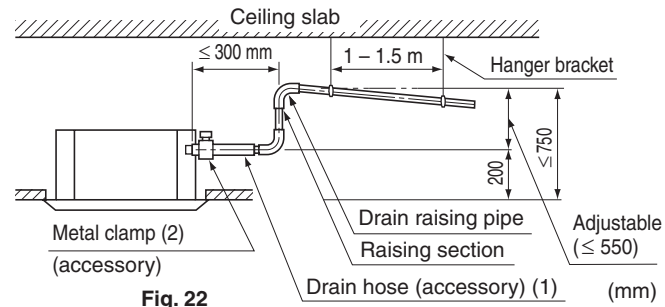

Fig. 21

3PA60996-14Y

<PRECAUTIONS FOR DRAIN RAISING PIPING>

- Install the drain raising pipes at a height of less than 550 mm.
- Install the drain raising pipes at a right angle to the indoor unit and no more than 300 mm from the unit.

**Fig. 22**

- Note:**
- To ensure no excessive pressure is applied to the included drain hose (1), do not bend or twist when installing. (This may cause leakage.)
 - If converging multiple drain pipes, install according to the procedure shown below.

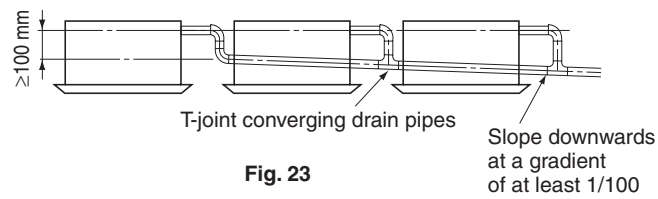
**Fig. 23**

Select converging drain pipes whose gauge is suitable for the operating capacity of the unit.





- (2) After piping work is finished, check if drainage flows smoothly.
 Add approximately 2 liter of water slowly from the air outlet and check drainage flow.

WHEN ELECTRIC WIRING WORK IS FINISHED

- Check drainage flow during COOL running, explained under "TEST OPERATION".

WHEN ELECTRIC WIRING WORK IS NOT FINISHED

- Remove the terminal box lid connect a power supply and remote control to the terminals.
 (Refer to the Installation Manual)

Next, press the inspection/test operation button "  " on the remote control. The unit will engage the test operation mode. Press the operation mode selector button "  " until selecting FAN OPERATION "  ". Then, press the ON/OFF button "  ". The indoor unit fan and drain pump will start up. Check that the water has drained from the unit. Press "  " to go back to the first mode.

- **Note that the fan also starts rotating.**

Attach the terminal box lid as before.

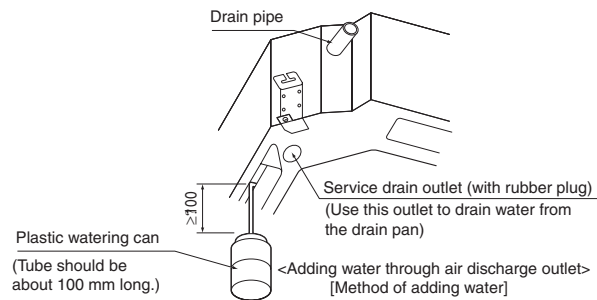

Fig. 24

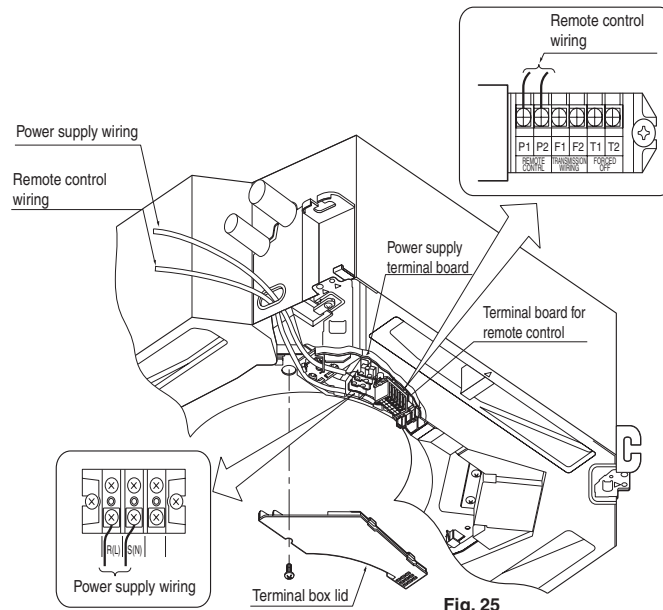

Fig. 25



Caution:

- Drain piping connections
 Do not connect the drain piping directly to sewage pipes that smell of ammonia. The ammonia in the sewage might enter the indoor unit through the drain pipes and corrode the heat exchanger.
- Keep in mind that it will become the cause of getting drain pipe blocked if water collects on drain pipe.

3PA60996-14Y

**Ceiling Mounted
Cassette Corner
Type (FXKQ-MA)**

Drain Piping Work

《Rig the drain pipe as shown below and take measures against condensation. Improperly rigged piping could lead to leaks and eventually wet furniture and belongings.》

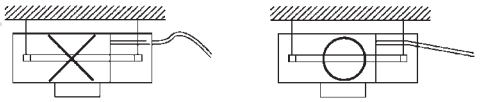

(1) Carry out the drain piping.

- Keep piping as short as possible and slope it downwards so that air may not be trapped inside the pipe.
- The diameter of the drain pipe should be greater than or equal to the diameter of the connecting pipe (vinyl tube; pipe size : 25 mm ; outer dimension : 32 mm).
- Use the drain hose and metal clamp. Insert the drain hose into the drain socket, up to the white tape. Tighten the metal clamp until the screw head is less than 4 mm from the hose.

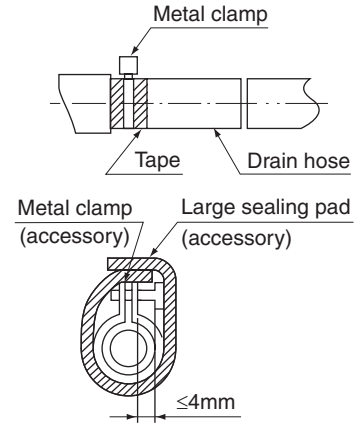

Caution

Setting the unit at an angle opposite to the drain piping might cause leaks.

- Wrap the sealing pad over the clamp and drain hose to insulate.
- Insulate the drain hose inside the building. While referring to the figure on the right, insulate the clamp and drain hose with the large sealing pad.
- If the drain hose cannot be sufficiently set on a slope, execute the drain raising piping.
- Secure a downward gradient of 1 / 100 or more for the drain pipe. To accomplish this, mount supporting brackets at an interval of 1 - 1.5 m.

《Precautions when doing drain-up piping work.》

- Make sure the drain-up piping is at most 330 mm high.
- Stand the drain-up piping horizontally, and make sure it is not further than 300 mm from the base of the drain socket.

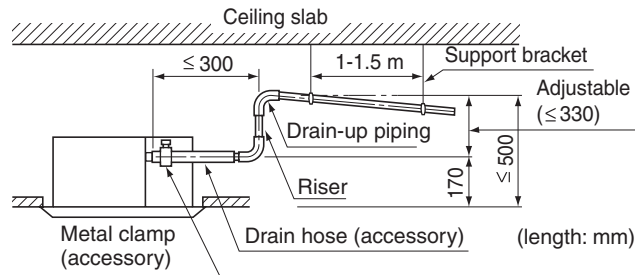

- Use the following outline if laying concentrated drain piping.
- If converging multiple drain pipes, install according to the procedure shown below.

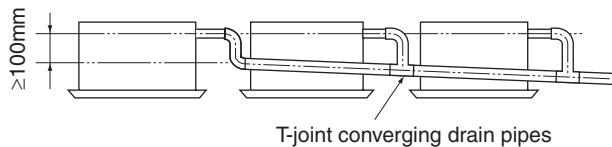

Select converging drain pipes whose gauge is suitable for the operating capacity of the unit.

3P086156-8V

- (2) After piping work is finished, check drainage flows smoothly.
- Open the inspection opening, add approximately 1liter of water slowly into the drain pan and check drainage flow.

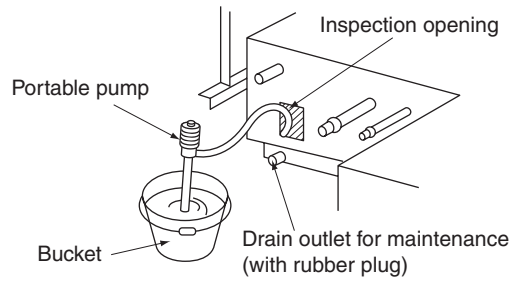

Note: Use the drain outlet for maintenance to drain water from the drain pan.





WHEN ELECTRIC WIRING WORK IS FINISHED

- Check drainage flow during COOL running, explained under “TEST OPERATION”.

WHEN ELECTRIC WIRING WORK IS NOT FINISHED

- Remove the electric parts box lid connect a power supply and remote control to the terminals.
(Refer to the **Installation Manual**)

Be sure attach the electric parts box lid before turning on the power.

Next, press the inspection/test operation button “” on the remote control. The unit will engage the test operation mode. Press the operation mode selector button “” until selecting FAN OPERATION “”. Then, press the ON/OFF button “”. The indoor unit fan and drain pump will start up. Check that the water has drained from the unit. Press “” to go back to the first mode.

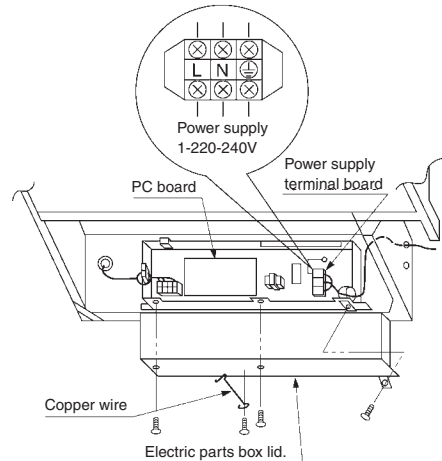

3P086156-8V

Caution

- Drain piping connections
Do not connect the drain piping directly to sewage pipes that smell of ammonia. The ammonia in the sewage might enter the indoor unit through the drain pipes and corrode the heat exchanger.
- Keep in mind that it will become the cause of getting drain pipe blocked if water collects on drain pipe.

**Slim Ceiling
Mounted Duct
Type (FXDQ)**

Drain Piping Work

1. Install the drain piping.

In case of PVE, NAVE (with Drain Pump) Type

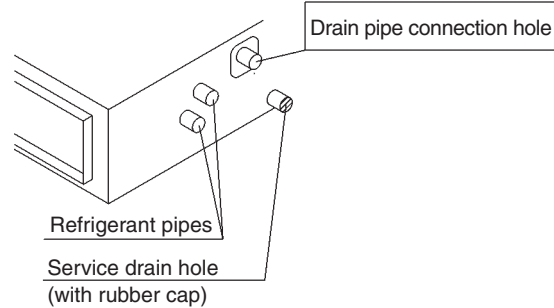

In case of PVET, NVET (without Drain Pump) Type

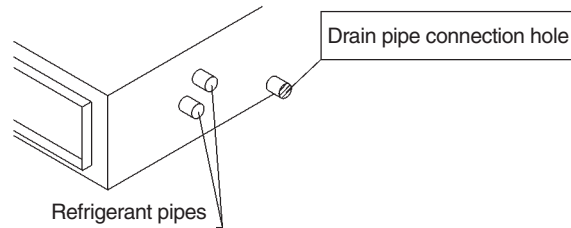

Connect the drain pipe after removing the rubber cap and insulation tubing attached to the connection hole.

- Make sure the drain works properly.
- The diameter of the drain piping should be greater than or equal to the diameter of the connecting pipe (vinyl tube; pipe size: 20 mm; outer dimension: 26 mm). (not including the riser)
- Keep the drain pipe short and sloping downwards at a gradient of at least 1/100 to prevent air pockets from forming. **(Refer to Fig. 10)**

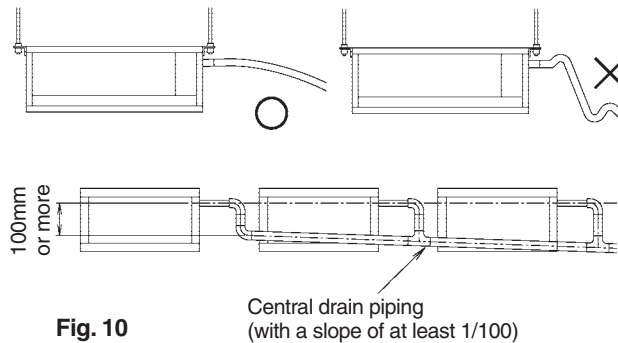

Fig. 10



Caution Water accumulating in the drain piping can cause the drain to clog.

- To keep the drain piping from sagging, space hanging bracket every 1 to 1.5 m.
- Use the drain hose (2) and the metal clamp (1). Insert the drain hose (2) fully into the drain pipe connection hole and firmly tighten the metal clamp (1) with the upper part of the tape on the hose end. Tighten the metal clamp (1) until the screw head is less than 4 mm from the hose. **(Refer to Fig. 11, 12)**
- The two areas below should be insulated because condensation may form there causing water to leak.
 - Drain piping passing indoors
 - Drain pipe connection hole

Referring the figure below, insulate the metal clamp (1) and drain hose (2) using the included large sealing pad (5). **(Refer to Fig. 12)**

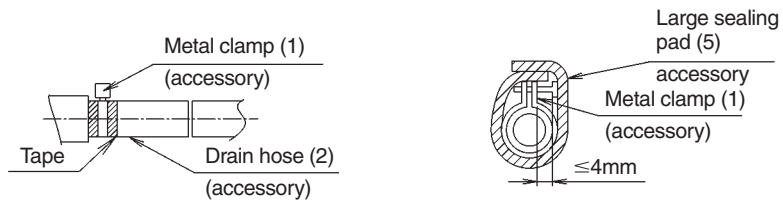

Fig. 11

Fig. 12

In case of PVE · N(A)VE (with Drain Pump) Type

3PN05141-4S

<PRECAUTIONS FOR DRAIN RAISING PIPE>

- Make sure the drain raising pipe height is no higher than 600mm.
- Place the drain raising pipe vertically and make sure it is no further than 300mm from the unit. **(Refer to Fig. 13)**

Fig. 13 is a schematic diagram showing the installation of a drain raising pipe. The pipe is connected to the unit and runs horizontally to a ceiling slab. The distance from the unit to the ceiling slab is labeled as '300 mm or less'. The pipe then runs horizontally along the ceiling slab, supported by a 'Hanging bracket'. The distance between the unit and the hanging bracket is labeled as '1 - 1.5m'. The vertical height of the pipe from the unit to the ceiling slab is labeled as 'Adjustable range (600mm or less)'. The pipe is labeled as 'Drain rising pipe (Field supply)'. Labels for 'Metal clamp (1) (accessory)' and 'Drain hose (2) (accessory)' are also present.

Fig. 13

<PRECAUTIONS>

Drain piping connections

- Do not connect the drain piping directly to sewage pipes that smell of ammonia. The ammonia in the sewage might enter the indoor unit through the drain piping and corrode the heat exchanger.
- Do not twist or bend the drain hose (2), so that excessive force is not applied to it. (This type of treatment may cause leaking.)
- If you are using central drain piping, follow the procedure outlined in the figure 10.
- Select central drain piping of proper size according to the capacity of the connected unit.

3PN05141-4S

2. After piping work is finished, check drainage flows smoothly.

- Gradually insert approximately 1L of water into the drain pan to check drainage in the manner described below.

In case of NVET Type

The diagram shows a portable pump connected to a bucket. The pump is used to draw water from the bucket and pour it into the drain pan through the drain outlet. Labels include 'Air outlet', 'Portable pump', 'Bucket', 'Refrigerant pipes', and 'Drain outlet'.

- Gradually pour approximately 1L of water from the outlet hole into the drain pan to check drainage.
- Check the drainage

**Ceiling Mounted
Built-in Type
(FXSQ-M)**

Drain Piping Work

<<Rig the drain pipe as shown below and take measures against condensation. Improperly rigged piping could lead to leaks and eventually wet furniture and belongings.>>

(1) Carry out the drain piping

- The diameter of the drain pipe should be greater than or equal to the diameter of the connecting pipe (vinyl tube; pipe size: 25 mm; outer dimension: 32 mm).
- Keep the drain pipe short and sloping downwards at a gradient of at least 1/100 to prevent air pockets from forming.
- If the drain hose cannot be sufficiently set on a slope, execute the drain raising piping.
- To keep the drain hose from sagging, space hanging wires every 1 to 1.5 m.

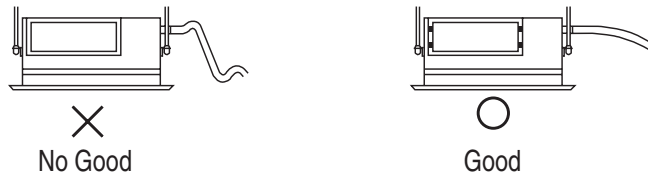

Caution

Setting the unit at an angle opposite to the drain piping might cause leaks.

- Use the attached drain hose and clamp metal. Tighten the clamp firmly. Insert the drain hose into the drain socket, up to the white tape. Tighten the clamp until the screw head is less than 4 mm from the hose.
- Wrap the attached sealing pad over the clamp and drain hose to insulate.
- Insulate the drain hose inside the building.

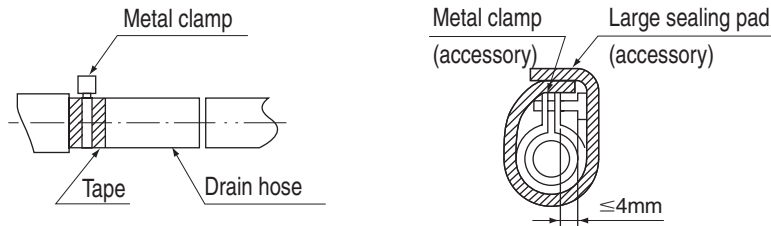

< PRECAUTIONS FOR DRAIN RAISING PIPING >

< HOW TO INSTALL PIPING >

- (1) Connect the drain hose to the drain raising pipes, and insulate them.
- (2) Connect the drain hose to the drain outlet on the indoor unit, and tighten it with the clamp.
- (3) Insulate both metal clamp and drain hose with the attached sealing pad.

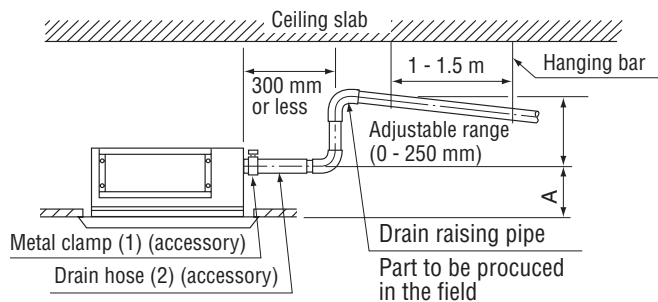

	A
When canvas duct is installed	350 - 530
When air inlet panel is directly installed	275

- If converging multiple drain pipes, install according to the procedure shown below.

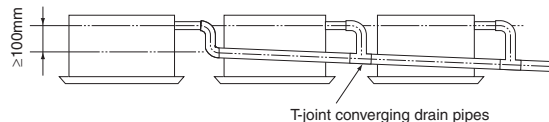

T-joint converging drain pipes

3P086156-3A-9

Select converging drain pipes whose gauge is suitable for the operating capacity of the unit.

Caution

- Drain piping connections
Do not connect the drain piping directly to sewage pipes that smell of ammonia. The ammonia in the sewage might enter the indoor unit through the drain pipes and corrode the heat exchanger.
- Keep in mind that it will become the cause of getting drain pipe blocked if water collects on drain pipe.

(2) After piping work is finished, check drainage flows smoothly.

- Open the water inlet lid, add approximately 1 liter of water gradually and check drainage flow.

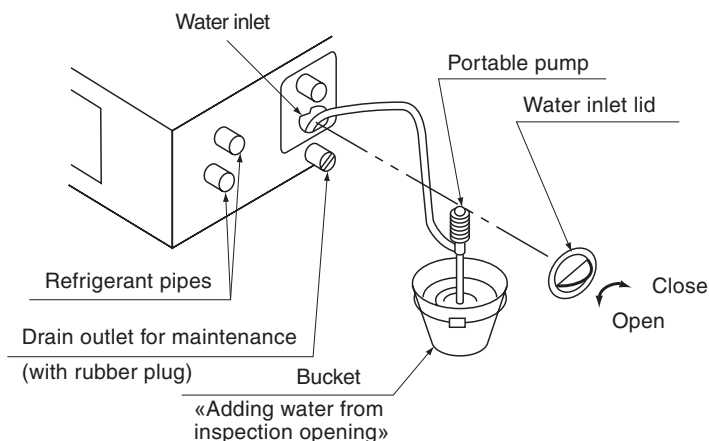

Note: Use this outlet to drain water from the drain pan.

[WHEN ELECTRIC WIRING WORK IS FINISHED]

- Check drainage flow during COOL running, explained under “TEST OPERATION”.

[WHEN ELECTRIC WIRING WORK IS NOT FINISHED]

- Remove the electric parts box lid, connect a power supply and remote control to the terminals.

(Refer to the “HOW TO CONNECT WIRINGS”)

Be sure attach the electric parts box lid before turning on the power.

Next, press the inspection/ test operation button “” on the remote control. The unit will engage the test operation mode.

Press the operation mode selector button

“” until selecting FAN OPERATION

“”. Then, press the ON/OFF button

“”. The indoor unit fan and drain pump will start up. Check that the water has drained

from the unit. Press “” to go back to the first mode.

- You can check whether drainage is satisfactory or not by removing the access opening lid and checking the water level of the drain pan through the access opening.
- **Be careful when doing so because the fan is turning at the same time.**

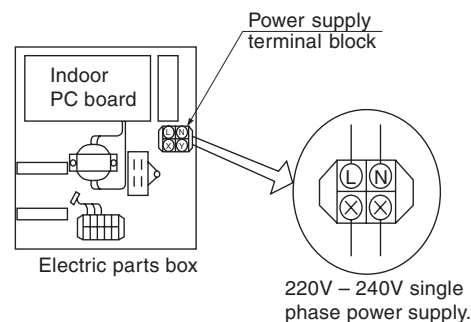

3P086156-7D

**Ceiling Mounted
Duct Type
(FXMQ-MA)**

Drain Piping Work

«Rig the drain pipe as shown below and take measures against condensation. Improperly rigged piping could lead to leaks and eventually wet furniture and belongings.»

«Insulate the drain hose inside the building.»

(1) Carry out the drain piping.

FXMQ40-125MAVE

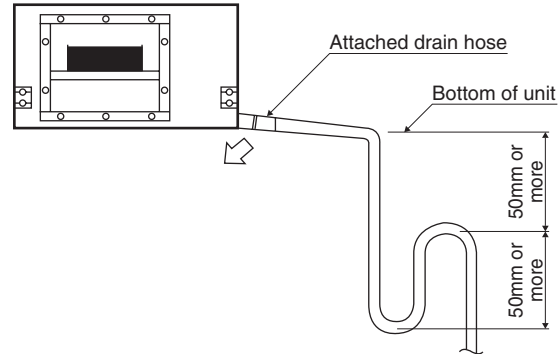

- Keep piping as short as possible and slope it downwards so that air may not remain trapped inside the pipe.
- Keep pipe size equal to or greater than that of the connecting pipe (Vinyl pipe of 25 mm nominal diameter and 32 mm outer diameter).
- Use the attached drain hose and clamp. Tighten the clamp firmly.
- Insulate the clamp metal with the sealing pad.

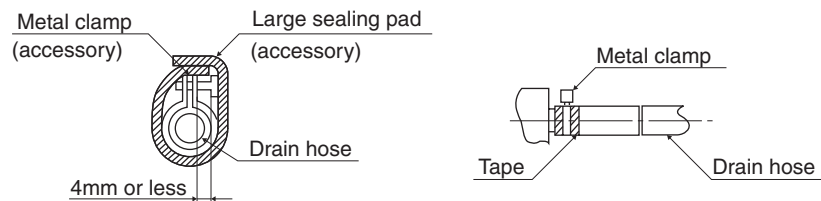

- There is negative pressure inside the unit relative to atmospheric pressure when the unit is running, so be sure to provide drain flap on the drain outlet. (See the figure)
- In order to prevent foreign matter from building up inside the piping, you should avoid curves as much as possible, and arrange so the trap can be cleaned.



Note:

- If converging multiple drain pipes, install according to the procedure shown below. (Install a drain trap for each indoor unit.)

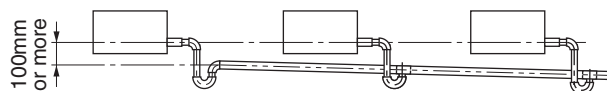

FXMQ200 · 250MAVE

- A drain trap need not be installed.
- The diameter of the piping is the same as that of the connecting pipe (PS1B), and should be kept equal to or greater than that of the connecting pipe.

(2) After piping work is finished, check drainage flows smoothly.

FXMQ40-125MAVE

- Add approximately 1 liter of water slowly from the air inlet and check drainage flow.

FXMQ200 · 250MAVE

- Open the water supply port, add approximately 1 liter of water slowly into the drain pan and check drainage flow.

**Caution**

- Drain piping connections

Do not connect the drain piping directly to sewage pipes that smell of ammonia. The ammonia in the sewage might enter the indoor unit through the drain pipes and corrode the heat exchanger.

C: 3P086156-6U

**Ceiling
Suspended Type
(FXHQ-MA)**

Drain Piping Work

Rig the drain pipe as shown below and take measures against condensation. Improperly rigged piping could lead to leaks and eventually wet furniture and belongings.

(1) Carry out the drain piping.

- For drain work, rig the pipes so that they drain reliably.
- The drain pipe outlet direction can be chosen from the right rear, right, left rear, and left. Refer to “REFRIGERANT PIPING WORK” for right rear and right direction, and refer to Fig. 20 for left rear and left direction.

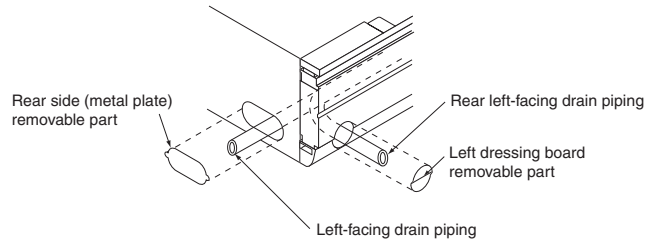

Fig. 20

- For left drain pipe outlet, remove the rubber plug and the insulation on the drain pipe connecting opening on the left side of the unit and change the position to the right side.
 - Insert the rubber stopper securely, all the way to the base, in order to prevent water leakage.
 - The diameter of the drain pipe should be greater than or equal to the diameter of the connecting pipe. (Vinyl tube; pipe size: 20 mm; outer dimension: 26 mm)
 - Keep the drain pipe short and sloping downwards at a gradient of at least 1/100 to prevent air pockets from forming. (Refer to Fig. 21)
 - Use the attached drain hose (1) and clamp (2).
- Insert the drain hose into the drain socket, up to the gray tape. (Refer to Fig. 22)
- Tighten the clamp until the screw head is less than 4 mm from the hose. (Refer to Fig. 23)
- (Be careful of the installation direction. Install so that the clamp metal does not contact the intake grill.)
- Wrap the attached sealing pad (8) over the clamp and drain hose to insulate. (Refer to Fig. 23)
 - No folding of drain hose inside the indoor unit. (Refer to Fig. 24)
- (If there is slack in the drain hose, it may cause damage to the intake grill.)

3PN01417-7P

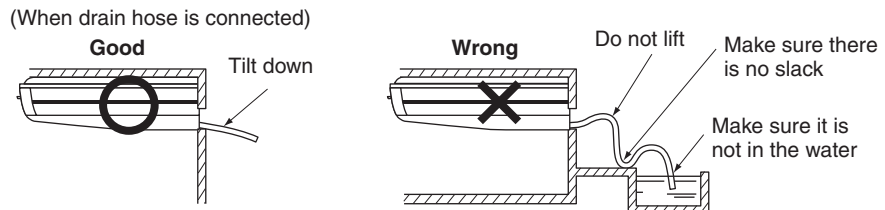

Fig. 21

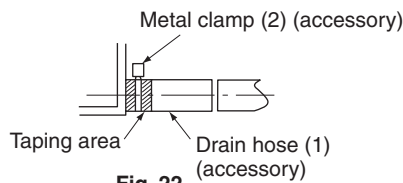

Fig. 22

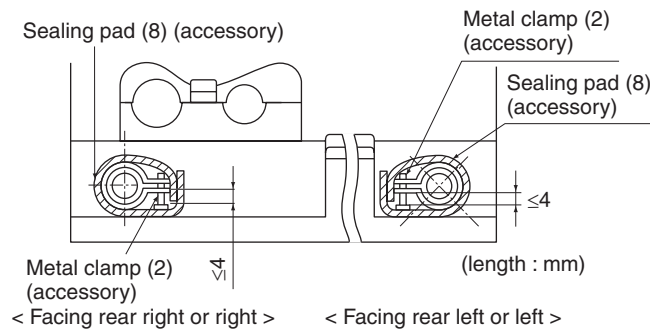
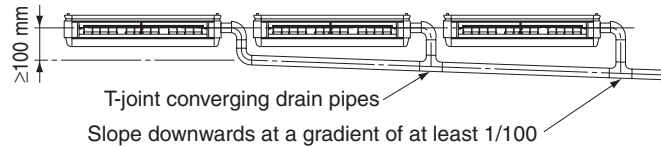

Fig. 23



- Notes:**
- To ensure no excessive pressure is applied to the included drain hose (1), do not bend or twist when installing. (This may cause leakage.)
 - If converging multiple drain pipes, install according to the procedure shown below.



Select converging drain pipes whose gauge is suitable for the operating capacity of the unit.

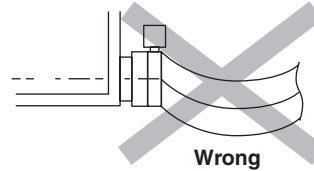

Fig. 24

(2) Confirm that smooth drainage is achieved after the piping work.

- Add 0.6 liter of water in the drain pan from the air outlet for confirming drainage.
(Refer to Fig. 25)

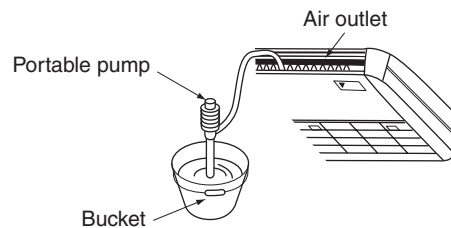

Fig. 25



Caution

- Drain piping connections
Do not connect the drain piping directly to sewage pipes that smell of ammonia. The ammonia in the sewage might enter the indoor unit through the drain pipes and corrode the heat exchanger.
- Keep in mind that it will become the cause of getting drain pipe blocked if water collects on drain pipe.

Wall Mounted Type (FXAQ-MA)

(1) Install the drain piping. (Refer to Fig. 16)

- The drain pipe should be short with a downward slope and should prevent air pockets from forming.
- Watch out for the points in the figure 16 when performing drain work.

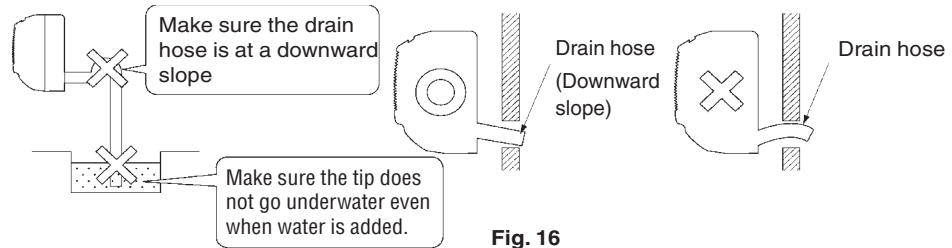

Fig. 16

- When extending the drain hose, use a commercially available drain extension hose, and be sure to insulate the extended section of the drain hose which is indoors. (Refer to Fig. 17)

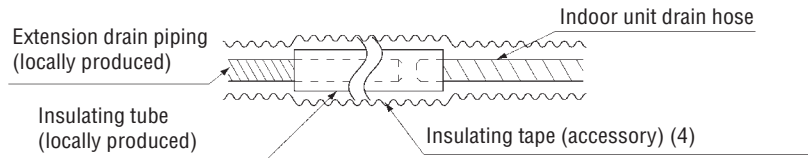

Fig. 17

- Make sure the diameter of the piping is the same as the piping (hard vinyl chloride, nominal diameter 13mm) or bigger.
- When directly connecting a hard vinyl chloride pipe joint (nominal diameter 13mm) to the drain hose connected to the indoor unit (i.e. for embedded piping, etc.), use a commercially available hard vinyl chloride pipe joint (nominal diameter 13mm). (Refer to Fig. 18)

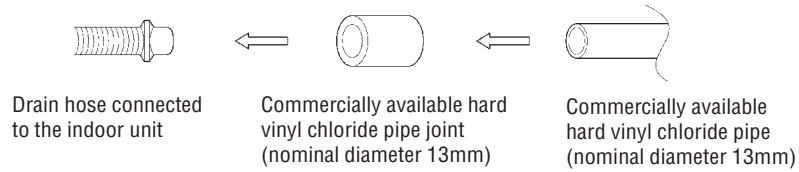

Fig. 18

(2) Make sure the drain works properly.

- After drain work is complete, perform a drain check by opening the front panel, removing the air filter, pouring water into the drain pan, and making sure the water flows smoothly out of the drain hose. (Refer to Fig. 19)

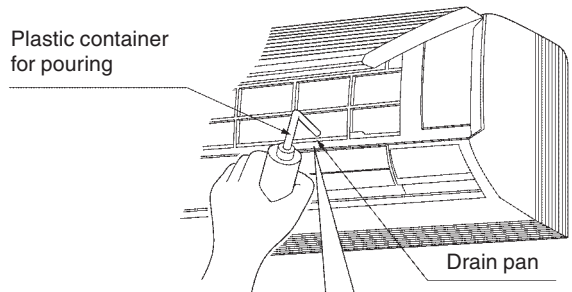

Fig. 19

Make sure not to splash the water.

Caution

Drain piping connections

Do not connect the drain piping directly to sewage pipes that smell of ammonia. The ammonia in the sewage might enter the indoor unit through the drain pipes and corrode the heat exchanger. Keep in mind that it will become the cause of getting drain pipe blocked if water collects on drain pipe.

C: 3P156215-6D

**Floor Standing/
Concealed Floor
Standing Type
(FXLQ-MA,
FXNQ-MA)**

Drain Piping Work

<<Rig the drain pipe as shown below and take measures against condensation. Improperly rigged piping could lead to leaks and eventually wet furniture and belongings.>>

(1) Carry out the drain piping.

Connect the drain hose (1) using the attached hose and parts, as shown in the right drawing.

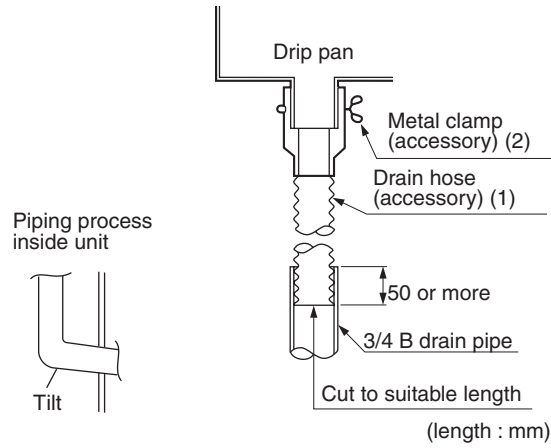

• If converging multiple drain pipes, install according to the procedure shown below.

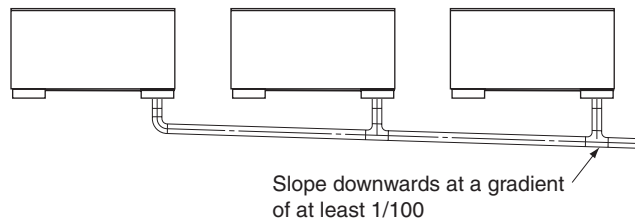

Select converging drain pipes whose gauge is suitable for the operating capacity of the unit.

(2) After piping work is finished, check drainage flows smoothly.

• Add approximately 1 liter of water slowly from the air outlet and check drainage flow.

(3) Be sure to insulate all indoor pipes.



Caution

■ Drain piping connections

Do not connect the drain piping directly to sewage pipes that smell of ammonia. The ammonia in the sewage might enter the indoor unit through the drain pipes and corrode the heat exchanger.

■ Keep in mind that it will become the cause of getting drain pipe blocked if water collects on drain pipe.

C: 3P086154-2K

**Ceiling
Suspended
Cassette Type
(FXUQ-MA)**

Drain Piping Work

1. Rig drain piping (Refer to Fig. 26)

As for drain work, perform piping in such a manner that water can be drained properly. As for drain piping, the connection can be made from three different directions.

- Employ a pipe with either the same diameter or with the diameter larger (excluding the raising section) than that of the connecting pipe (PVC pipe, nominal diameter 20 mm, outside diameter 26 mm).
- Keep the drain pipe short and sloping downwards at a gradient of at least 1/100 to prevent air pockets from forming. **(Refer to Fig. 27)**



Caution

Water pooling in the drainage piping can cause the drain to clog.

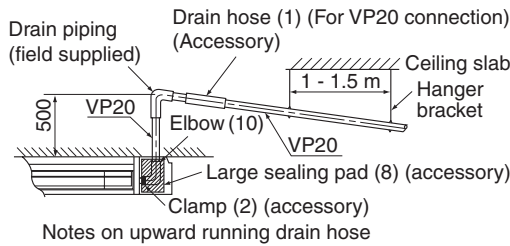

Fig. 26

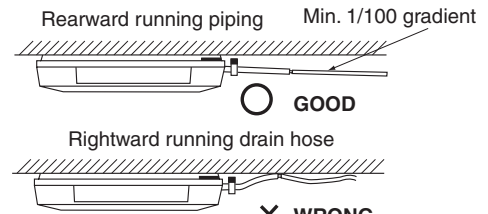

Fig. 27

(V2327)

- To keep the drain hose from sagging, space hanging wires every 1 to 1.5 m. **(Refer to Fig. 26)**
- Use only the included drain hose (1), (for rightward running drain hose) or elbow (10) (for upward running drain hose) and clamp (2).
- Fit the drain hose (1) or elbow (10) over the drain pipe up to the neck and fasten tight with the clamp (2).
- Insulate the clamp (2) and drain hose or elbow (10) with the included sealing pad (8). **(Refer to Fig. 28)**
- Make sure that heat insulation work is executed on the following 2 spots to prevent any possible water leakage due to dew condensation.
 - Insulate the drain hose inside the building.
 - Drain socket

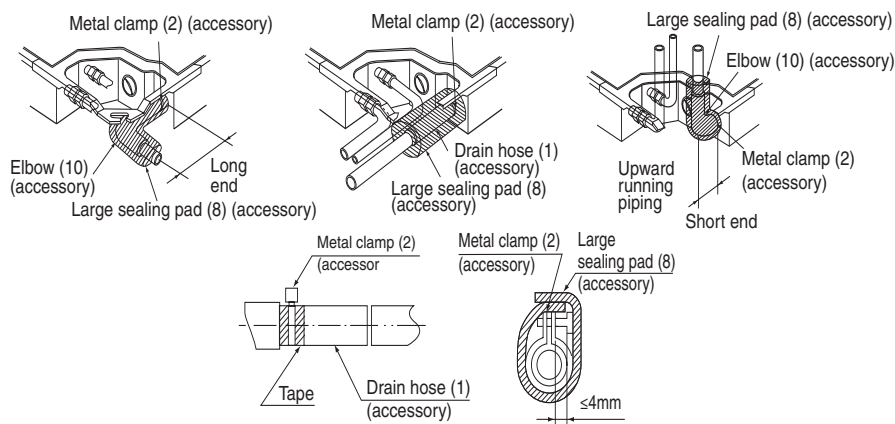

Fig. 28



Caution

- Do not twist or bend the drain hose (1), so that excessive force is not applied to it, as this could cause leaks.
- If converging multiple drain piping, install according to the procedure shown below. **(Refer to Fig. 29)**

Select converging drain piping whose gauge is suitable for the operating capacity of the unit.

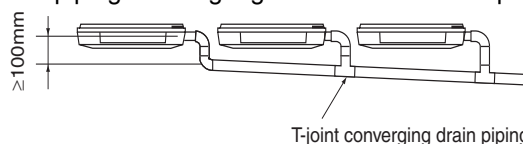
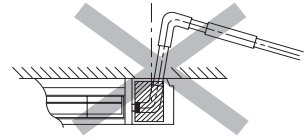

Fig. 29

PRECAUTIONS FOR UPWARD DRAIN RAISING PIPING

- Install the drain raising pipes at a height of less than 500 mm.
- Install the drain raising pipes at a right angle to the indoor unit. (Refer to Fig. 30)



WRONG
Fig.30

**Caution**

If the upward running drain hose leans at a slant, the float switch will malfunction and water will leak.

(V2328)

2. After piping work is finished, check if drainage flows smoothly.

- Open the water inlet lid, add approximately 1 liter of water slowly and check drainage flow.

(Refer to Fig. 31)

**Method of adding water**

Fig.31

(V2329)

[Caution]

Drain piping connections

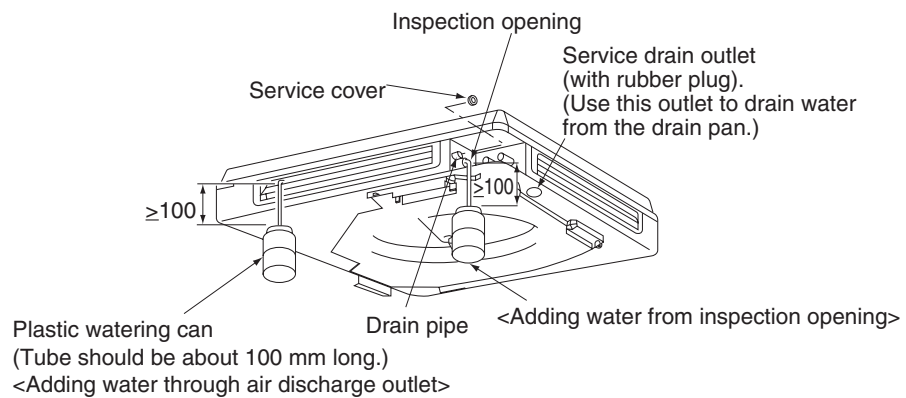
- Do not connect the drain piping directly to sewage pipes that smell of ammonia. The ammonia in the sewage might enter the indoor unit through the drain pipes and corrode the heat exchanger.

**Caution**

- Electrical wiring work should be done by a certified electrician.
- If someone who does not have the proper qualifications performs the work, perform the following after the test run is complete.
- Remove the control box lid and change the emergency switch above the PC board assembly of the indoor unit from “NORM.” to “EMERG.”. Connect the single-phase power supply (1, 3) and ground wire to the inter-unit wiring (50Hz 220-240V) terminal block and confirm drain operation. Be sure to change the switch before turning on the power. **(Refer to Fig. 32)**

**Caution**

- Clamp solidly to clamp C to tension is not added to the wiring connections.
- Be aware that the fan will turn during the operation.
- After confirming drainage, turn off the power and be sure to change the emergency switch back to “NORM.”.

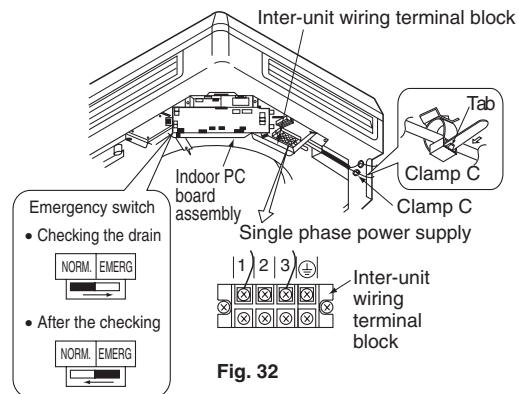

(V2330)

Outdoor Air Processing Unit (FXMQ-MF)

Drain Piping Work

<<Rig the drain pipe as shown below and take measures against condensate. Improperly rigged piping could lead to leaks and eventually wet furniture and belongings.>>
<<Insulate the drain pipes inside the building and the drain sockets.>>

1. Carry out the drain piping.

- The drain pipe should be short with a downward slope lower than 1/100 and should prevent air pockets from forming.
- The diameter of the pipe is the same as that of the connecting pipe (PS1B), and should be kept equal to or greater than that of the connecting pipe.

Note:

- If converging multiple drain pipes, install according to the procedure shown below. (Select an appropriate central drain pipe thickness for the units they will be connected to.)

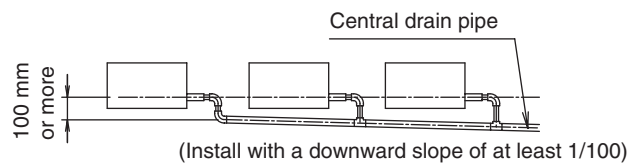

Fig. 12

2. After piping work is finished, check drainage flow smoothly.

- Open the water supply port, add approximately 1 liter of water slowly into the drain pan and check drainage flow. **(Refer to Fig. 13)**
Pools of drainage can cause the drain pipes to clog.

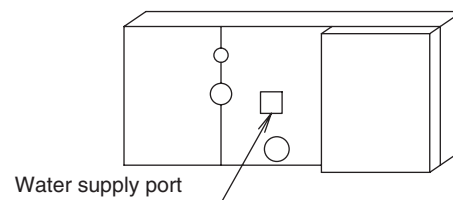

Fig. 13



Caution

Do not connect the drain pipe directly to sewage pipes that smell of ammonia. The ammonia in the sewage might enter the unit through the drain pipes and corrode the heat exchanger.

3.2.10 Electrical Work

Control Wiring

1. Compatible types of wire

Wiring Specifications

Wiring Type	Shield Wire (2 wire) (See NOTE 1, 2)
Size	0.75~1.25 mm ²



Notes:

1. Sheathed wire may be used for transmission wirings, but they do not comply with EMI (Electromagnetic Interference) (EN55014). When using sheathed wire, EMI must conform to Japanese standards stipulated in the Electric Appliance Regulatory Act. (If using a sheathed wire, the grounding shown in the figure on the left is unnecessary.)
2. For FXYAP indoor unit, use sheathed wire.

2. Problems arising from the use of unsuitable cable

a) When cable less than 0.75 mm² is used

Where the control wiring is particularly long the transmission signals may, for example, become unstable and the terminal relay cease to function. (Reduced voltage) The control system may become unduly subject to noise interference.

b) When cable more than 1.25 mm² is used

When wiring indoor units together, the terminal block will not be able to accommodate 2 cables simultaneously if the cables are larger than 1.25 mm².

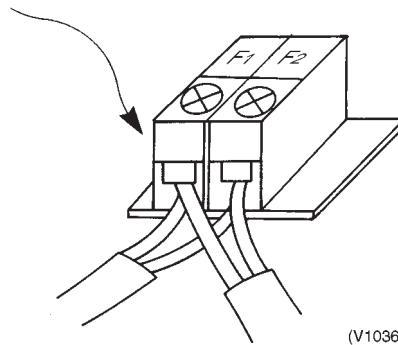

(V1036)

c) For multi-core cable

The greater play between wires, the more the transmitted wave is distorted and transmission destabilized.

d) In the case of a remote control with a three way selector for cooling, heating and ventilation, twin core cable should be used when the ventilation mode is not required and three core cable should be used when three way selection is required.

e) Since there is a considerable risk of mixing high (220 to 240V) and low voltage in the case of, for example, a PCB for remote control, multiple core cable must not be used. (Internal wiring regulations and dielectric strengths of cables are relevant here.)

[Example of incorrect method]

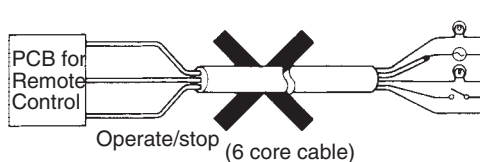

[Example of correct method]

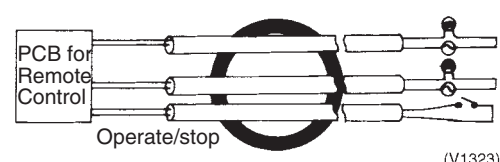

(V1323)

f) Other important points

1. The refrigerant circuit and the indoor/outdoor connecting cables must correspond exactly.
2. A suitable gap must be left between the control cables and the power supply cables where these are laid alongside each other. (See "Separation of control and power supply cables" on page 73)

**Power Supply
(Cabling of Main
Power Supply)**

1. Choosing a circuit breaker

The power supply work must conform to local regulations. In Japan, the relevant regulations are the MITI ordinance determining technical standards for electrical equipment, and the Internal Wiring Provisions.

a) The indoor unit circuit breakers

- In accordance with the provisions for internal wiring (JEAC8001-1986), power may be supplied by means of crossover lines between the indoor units in a single system branch circuit.

Branch circuit facility (Internal wiring provisions 305-2)
The motors must be set up with a dedicated branch circuit for each unit. However, where they correspond to any of the following situations, this limitation does not apply.

① When used in a 15A branch circuit of a 20A circuit breaker branch circuit

Note: It is recommended that the total rated capacity of the motors set up in a 15A branch circuit or a 20A circuit breaker branch circuit should be no more than 2.2kW.

Example of 15A branch circuit or 20A circuit breaker branch circuit

When using high static pressure indoor units the fan motors must have a large capacity. Single phase 220~240V branch circuits are therefore required for each indoor unit.

Example: Up to 10 × 2.5HP indoor units or 5 × 5HP indoor units can be wired together.

b) The outdoor unit circuit breaker

- A separate circuit breaker must be fitted for each unit.
- The motors incorporated into air conditioning system compressors are treated as special motors under the internal wiring provisions. The values which apply to normal motors are thus somewhat variance with those which apply to such compressor motors. You are recommended to adhere strictly to the procedures laid down in the technical materials included in, for example, the system design manuals.

Calculation of load (Refer to local regulation.)

With respect to the calculation of load for motors with special applications such as elevator, air conditioner and refrigerator motors, not only must the rated current be shown on the name plate of the said motor or piece of apparatus but it must also included all special characteristics or applications.

i Note1: The rated current for package air conditioners which use special purpose built-in compressor motors in their compressors in 1.2 times the operating current shown on the name plate.

i Note2: Refer 1.7 (or 2.7) Field Wiring on each installation manual for detail power supply and circuit breaker.

2. Cable size

The thickness of the cables in the circuits (branch circuits) providing the main power supply to each item of apparatus must satisfy the following conditions:

1. To have a current tolerance of 40% or more of the rated current of the overcurrent circuit breaker (wiring circuit breaker, etc.).
2. To have a current tolerance of 125% or more of the rated current in cases where the rated current of the apparatus is 50A or less.
3. To have a current tolerance of 110% or more of the rated current in cases where the rated current of the apparatus is more than 50A.
4. To satisfy voltage drop standards.

3. Separation of control and power supply cables

■ **If control and power cables are run alongside each other** then there is a strong likelihood of operational faults developing due to interference in the signal wiring caused by electrostatic and electromagnetic coupling.

The table below indicates our recommendations as to the appropriate spacing of control and power cables **where these are to be run side by side**.

Current capacity of power cable		Spacing
100V or more	10A or less	300mm
	50A	500mm
	100A	1000mm
	100A or more	1500mm



Notes:

1. The figures are based on an assumed length of parallel cabling up to 100m. For lengths in excess of 100m the figures will have to be recalculated in direct proportion to the additional length of cable involved.
2. If the power supply waveform continues to exhibit some distortion the recommended spacing in the table should be increased.

If the cables are laid inside conduits then the following points must also be taken into account when grouping various cables together for introduction into the conduits.

1. Power cables (including power supply to the air conditioner) and signal cables must not be laid inside the same conduit. (Power cables and signal cables must each have their own individual conduits.)
2. In the same way, when grouping the cables, power and signal cables should not be bunched together.

■ **Important points**

1. Earthing

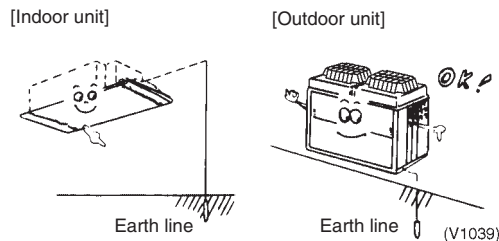

■ Have the indoor and outdoor units both been earthed?

- * If the apparatus is not properly earthed then there is always a risk of electric shocks. The earthing of the apparatus must be carried out by a qualified person.

3.2.11 Duct Work (Indoor)

■ Operational steps

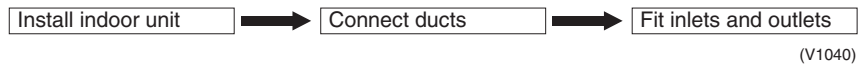

Taking Account of Noise and Vibration

- a) Canvas joints must be used between the main unit and the air suction and discharge ducts. These fittings are designed to inhibit secondary noise resulting from the transmission of vibrations and operating noise from the main unit to the ducts or to the rest of the building.

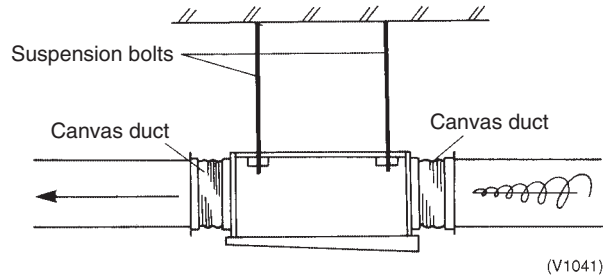

- b) The speed of the airflow should be taken into account when choosing air suction and distribution grills in order to keep wind noise to minimum.

■ Important points

1. The air discharge duct must be thermally insulated.
2. The canvas duct on the inlet side must be set in a metal framework.
3. The air suction and distribution grills should be positioned to take into account the possibility of short circuits.
4. Static pressure should be checked to ensure that the airflow is within the specified range.
5. The air filter must be easily detachable.

3.2.12 Selection of Location

This unit, both indoor and outdoor, is suitable for installation in a commercial and light industrial environment. If installed as a household appliance it could cause electromagnetic interference. The VRV outdoor units should be installed in a location that meets the following requirements:

1. The foundation is strong enough to support the weight of the unit and the floor is flat to prevent vibration and noise generation.
2. The space around the unit is adequate for servicing and the minimum space for air inlet and air outlet is available. (Refer to below figure and choose one of both possibilities.)
3. There is no danger of fire due to leakage of inflammable gas.
4. Ensure that water cannot cause any damage to the location in case it drips out the unit (e.g. in case of a blocked drain pipe).
5. The piping length between the outdoor unit and the indoor unit may not exceed the allowable piping length. (See "Example of connection".)
6. Select the location of the unit in such a way that neither the discharged air nor the sound generated by the unit disturb anyone.
7. Make sure that the air inlet and outlet of the unit are not positioned towards the main wind direction. Frontal wind will disturb the operation of the unit. If necessary, use a windscreen to block the wind.

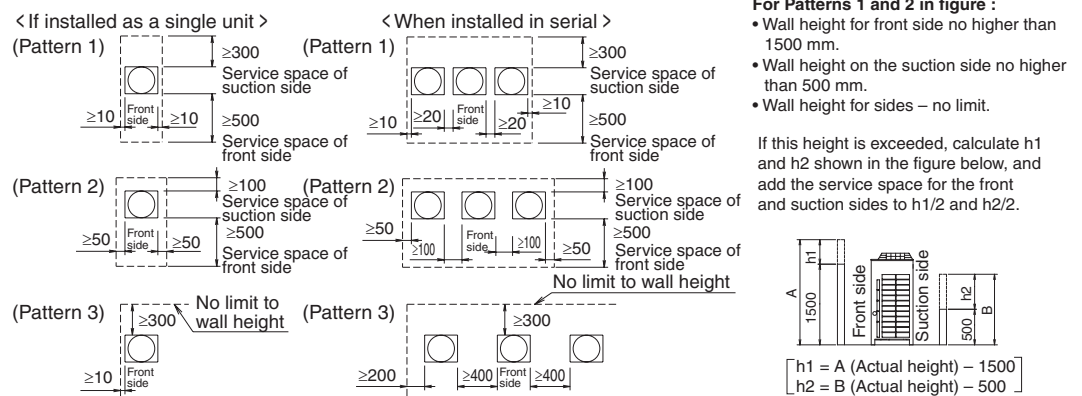

Caution

1. An inverter air conditioner may cause electronic noise generated from AM broadcasting. Examine where to install the main air conditioner and electric wires, keeping proper distances away from stereo equipment, personal computers, etc.

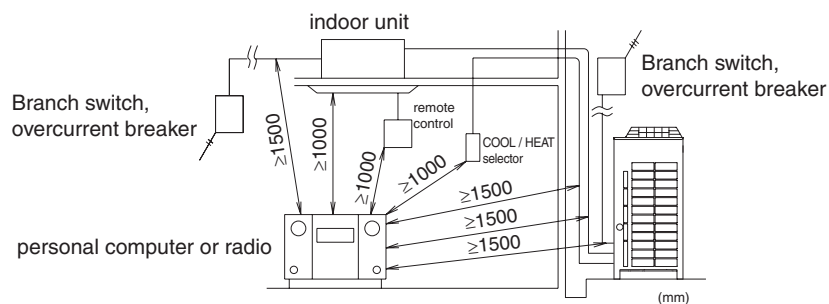

If the electric wave of AM broadcasting is particularly weak, keep distances of 3m or more and use conduit tubes for power and transmission lines.

2. In heavy snowfall areas, select an installation site where snow will not affect operation of the unit.
3. If condensate may drip on downstairs (walkway) depending on the floor condition, take a measure such as the installation of central drain pan kit (sold separately).
4. The refrigerant R-410A itself is nontoxic, nonflammable and is safe. If the refrigerant should leak however, its concentration may exceed the allowable limit depending on room size. Due to this it could be necessary to take measures against leakage. Refer to the chapter "Caution for refrigerant leaks".

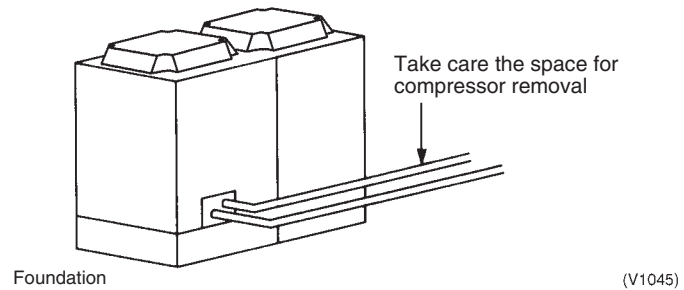

Service Space

It is extremely important that enough space is left when installing the equipment to allow routine servicing and maintenance to be carried out without undue hindrance. It is particularly important to bear in mind the work which will be required if the compressor needs to be replaced. (The layout of the pipework can sometimes cause considerable difficulties if the compressor needs to be changed.)



(V1045)

3.2.13 Inspecting and Handling the Unit

- At delivery, the package should be checked and any damage should be reported immediately to the carrier claims agent.
- When handling the unit, take into account the following:
 1.  Fragile, handle the unit with care.
 2.  Keep the unit upright in order to avoid compressor damage.
- 2. Decide on the transportation route.
- 3. If a forklift is to be used, pass the forklift arms through the large openings on the bottom of the unit.

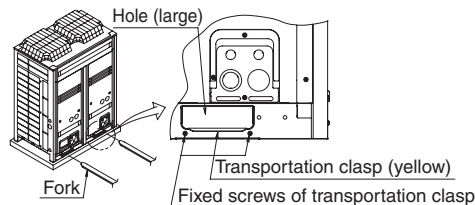

4. If hanging the unit, use a cloth sling to prevent damaging the unit when hanging it. Keeping the following points in mind, hang the unit following the procedure shown in figure 6.
 - Use a sling sufficiently strong to hold the mass of the unit.
 - Use 2 belts of at least 8m long.
 - Place extra cloth or boards in the locations where the casing comes in contact with the sling to prevent damage.
 - Hoist the unit making sure it is being lifted at its center of gravity.
5. After installation, remove the transportation clasp attached to the large openings.

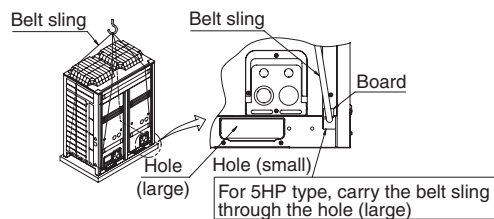

Notes:

- Use belt sling of 20mm width or less which adequately bears the weight of the product.
- Apply a filler cloth on a fork to prevent coating of the bottom frame from coming off and rust from occurring when bringing in the unit with anti-corrosion treatment type using a forklift.

3.2.14 Installation of Outdoor Unit

■ Operational steps



(V1150)

Foundation of Units

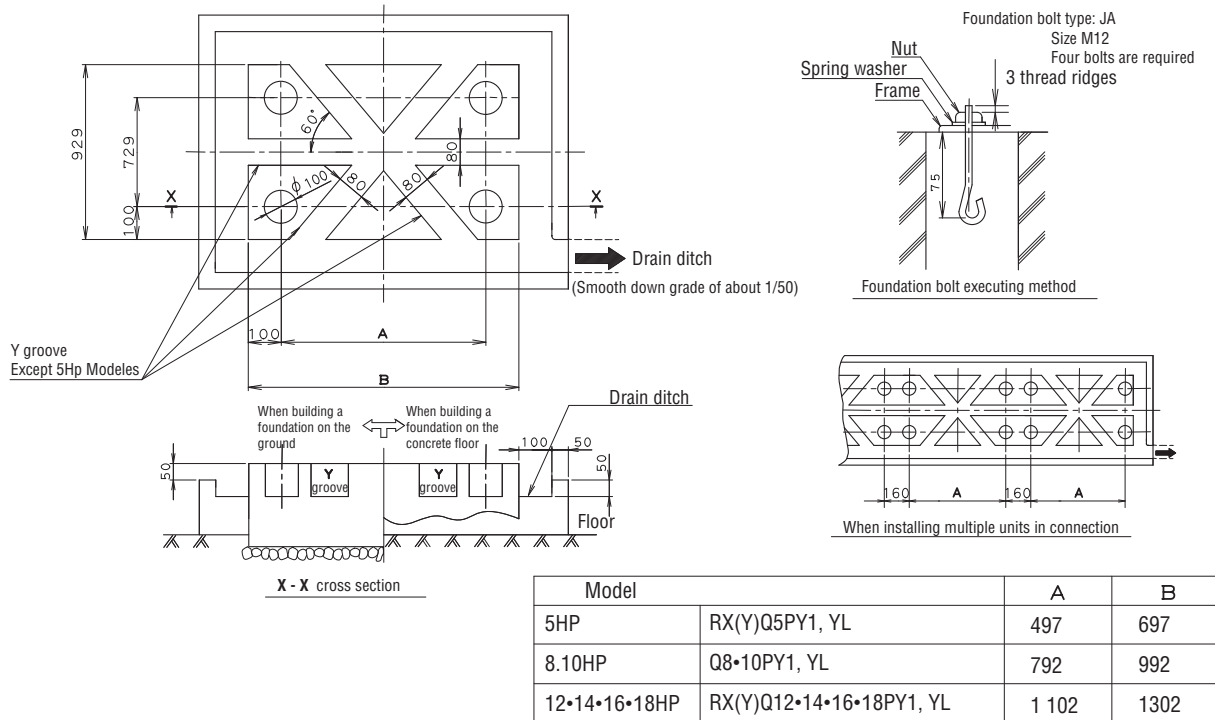

Model		A	B
5HP	RX(Y)Q5PY1, YL	497	697
8.10HP	Q8•10PY1, YL	792	992
12•14•16•18HP	RX(Y)Q12•14•16•18PY1, YL	1 102	1302

C:3D040102P



Notes:

1. The proportions of cement : sand : gravel for the concrete shall be 1 : 2 : 4, and ten reinforcement bars that their diameter are 10mm, (approx. 300mm intervals) shall be placed.
2. The surface shall be finished with mortar. The corner edges shall be chamfered.
3. When the foundation is built on a concrete floor, rubble is not necessary. However, the surface of the section on which the foundation is built shall have rough finish.
4. A drain ditch shall be made around the foundation to thoroughly drain water from the equipment installation area.
5. When installing the equipment on a roof, the floor strength shall be checked, and water-proofing measures shall be taken.
6. Y groove unnecessary for 5HP Models.
7. When selecting the piping from the bottom, provide the height 200mm or more from a base.

Unpacking and Placing the Unit

Bolt Pitch

- Make sure the unit is installed level on a sufficiently strong base to prevent vibration and noise.
- Secure the unit to its base using foundation bolts. (Use four commercially available M12-type foundation bolts, nuts, and washers.)
- The foundation bolts should be inserted 20 mm.
- Make sure the base under the unit extended more than 765mm behind the unit.
- The height of the base should be at least 150mm from the floor.
- The unit must be installed on a solid longitudinal foundation (steelbeam frame or concrete) as indicated in figure.

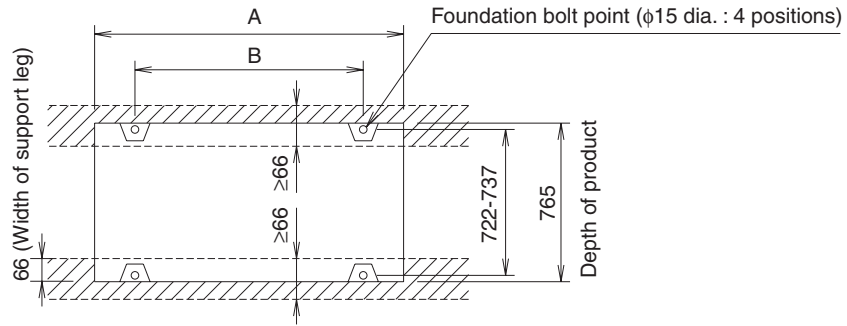
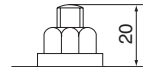

Shape of outdoor unit's support leg and foundation bolt positions

Model		A	B
5HP	RX(Y)Q5PY1, YL	635	497
8.10HP	RX(Y)Q8•10PY1, YL	930	792
12•14•16•18HP	RX(Y)Q12•14•16•18PY1, YL	1240	1102



Notes:

1. When installing on a roof, make sure the roof floor is strong enough and be sure to water-proof all work.
2. Make sure the area around the machine drains properly by setting up drainage grooves around the foundation.
Drain water is sometimes discharged from the outdoor unit when it is running.
3. For anti-corrosion type use nuts with resin washers. If the paint on nut connections comes off, the anti-corrosion effect may decrease.

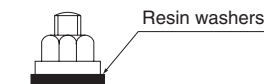

Do not Use Stands to Support The Corners

In the case of 8HP type or more, the product cannot be supported with four corners. In the case of 5HP type, the product can be supported with four corners.

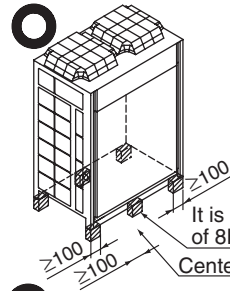
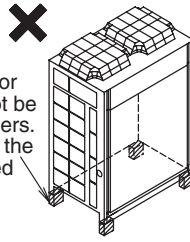

It is need in the case of 8HP type or more
Center of the product

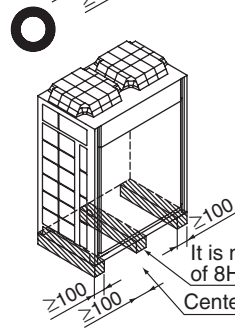
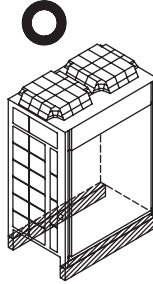

It is need in the case of 8HP type or more
Center of the product



Caution Caution label

To Installers

1. When carrying the unit

- If a forklift is used for carrying the unit, put the forklift arms into the large openings on the bottom of the unit.
- ✖ In order not to damage the coating of the bottom frame, put rags on the forklift arms. (Otherwise rustproofing effect will be lost)
- After installation, remove the transport claps attached to the large openings.

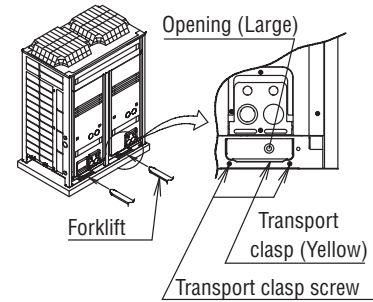

2. When lifting the unit

- Put the belt slings into the small openings.
- (For 5HP unit, into the large openings)
- Lift the unit with 2 belts of at least 8m long.
- Put cushioning plates or rags where the slings contact the casing.

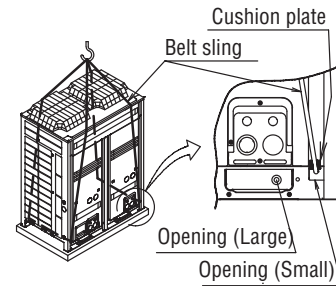

3. Electrical work

- To prevent electric shock and fire accident, be sure to perform grounding and install an earth leak breaker.
- Electrical work must be carried out by a licensed electrician in accordance with local and national regulations.

3P170269B

To Service Person

⚠ WARNING ⚠ Caution to electric shock

- Beware the fan running when inspect.
- Do not touch the charged parts when inspect

Check the system status on LED(H2P) on the Pc board (A1P) from inspection door on the EL, COMPO, BOX cover.

LED display shows:

TURNING OFF***Normal TURNING ON***Abnormal

FLASHING***Under preparation

(For multi system, check the PC board of the master unit. The master unit is the outdoor unit connected to the transmission wiring to the indoor units.)

To ALL handlers

- For removing the front panel, lift the panel a little (①), and pull the panel towards you (②).
- For the location of the EL, COMPO. BOX and the service port, see as shown below on the right.

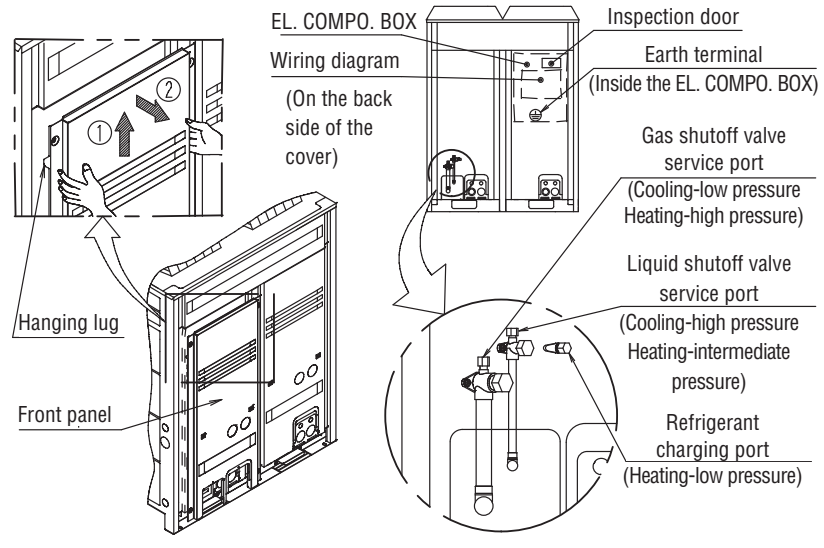

3P170269B

CAUTION for removing and installing the EL, COMPO. BOX cover

Method of removal

- ① Remove the 4 screws fixing the cover.
- ② Pull the cover downward till its top shows.
- ③ Pull the cover frontward and remove it.

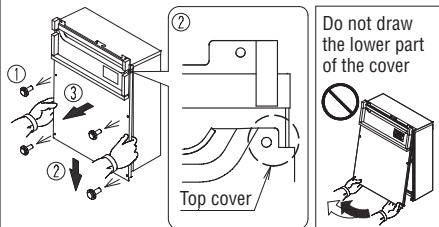

CAUTION

- Do not remove the cover by force. If the cover is deformed, water may enter inside, which may cause failure.
- Install the cover so that the sealing material labeled on the lower part on its back side may not get caught in the EL, COMPO. BOX inside. (See as shown below)

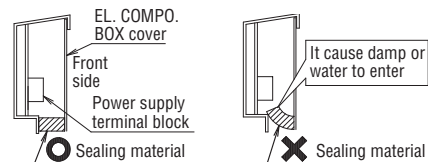

Method of installation

For installing the cover, follow the procedures in the reverse order.

⚠ WARNING ⚠ Caution to electric shock

Shut off the power supply before removing the cover. If your fingers touch the electrical components it may cause electric shock.

3P173367B

4. Test Operation

4.1 Procedure and Outline

Follow the following procedure to conduct the initial test operation after installation.

4.1.1 Check Work Prior to Turn Power Supply On

Check the below items.

- Power wiring
- Control transmission wiring between units
- Earth wire



- Is the wiring performed as specified?
- Is the designated wire used?
- Is the wiring screw of wiring not loose?
- Is the grounding work completed?
- Is the insulation of the main power supply circuit deteriorated?
 - Use a 500V megger tester to measure the insulation. (*1)
 - Do not use a megger tester for other circuits than 200V (or 240V) circuit.

*1: Measure to be taken against decreased insulation resistance in the compressor

If the compressor is left to stand for an extended period of time after the refrigerant charge with the stop valve open and the power supply OFF, the refrigerant may be mixed in the compressor, thus decreasing the insulation resistance.

Heat the compressor as shown on the right and then recheck the insulation.

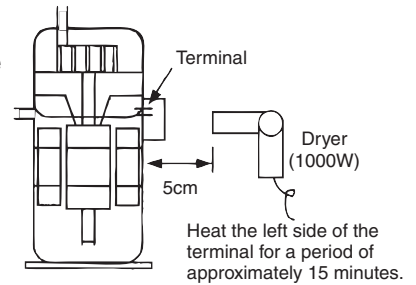

Check on refrigerant piping / insulation materials



- Is the pipe size proper?
- Is the pipe insulation material installed securely?
 - Liquid and gas pipes need to be insulated. (Otherwise causes water leak.)

Check airtight test and vacuum drying.



- Have the airtight test and the vacuum drying been conducted according to the procedure in the Installation Manual?

Check on amount of refrigerant charge



- Is a proper quantity of refrigerant charged?
 - Calculate the “additional charging amount” using “How to calculate the additional refrigerant to be charged” in “2-6-5 Example of connection”.
 - If the “additional charging amount” was not charged fully, charge proper amount of refrigerant.

Check the stop valves for conditions.

- Check to be sure the stop valves are under the following conditions.

Liquid-side stop valve	Gas-side stop valve
Open	Open

4.1.2 Turn Power On

Turn outdoor unit and indoor unit power on.



Check the LED display of the outdoor unit PC board.



Make field settings with outdoor unit PC board.



Conduct check operations.



Check for normal operation.

○ Be sure to turn the power on 6 hours before starting operation to protect compressors. (to power on clankcase heater)

○ Check to be sure the transmission is normal.
The transmission is normal if the LEDs display conditions as shown in table below.

LED display ○ ON ● OFF ● Blinking

LED display (Default status before delivery)	Micro-computer operation monitor	MODE	TEST	COOL / HEAT select			Low noise	Demand	Multi
				IND	MASTER	SLAVE			
				HAP	H1P	H2P			
One outdoor unit installed	●	●	●	○	●	●	●	●	●
When multiple outdoor unit installed (*)	Master	●	●	●	○	●	●	●	○
	Slave 1	●	●	●	●	●	●	●	●
	Slave 2	●	●	●	●	●	●	●	●

(*) The master unit is the outdoor unit to which the transmission wiring for the indoor units is connected.
The other outdoor units are slave units.

○ Make field settings if needed.
(For the setting procedure, refer to information in "4.4.2. Field Setting from Outdoor Unit" on page 101 onward.)
For the outdoor-multi system, make field settings with the master unit. (Field settings made with the slave unit will be all invalid.)

The check operations shown below will be automatically initiated.

- Check for erroneous wirings
- Check for failure to open stop valves
- Check for excessive refrigerant refilling
- Automatic judgment of piping length

○ Before starting the normal operation after the completion of check operations, make sure indoor and outdoor units normally operate.

4.1.3 Check Operation

[Check Operation Procedure]

- STEP1** Make the onsite setting as needed using the dip switches on the outdoor unit PC-board (A1P) with the power off (See below instruction Note1)
- STEP2** Close the EL. COMPO. BOX lid and all front panels except as the side of the EL. COMPO. BOX and turn on the power to the outdoor unit and all connected indoor units. (Be sure to turn the power on at least 6 hours before operation in order to have power running to the crank case heater.)
- STEP3** Check the LED display on the outdoor unit PC-board (A1P) is as shown in the table below and transmission is normal.

LED display (Default status of shipped)	SERV. MONI-TOR	MODE	TEST/HWL	C/H SELECTOR			L.N.O.P	DEMA-ND	MULTI
				IND	MASTE R	SLAVE			
				H3P	H4P	H5P			
Single system	⦿	●	●	☀	●	●	●	●	●
Multi system (*)	Master unit	⦿	●	●	☀	●	●	●	☀
	Sub unit 1	⦿	●	●	●	●	●	●	⦿
	Sub unit 2	⦿	●	●	●	●	●	●	●

LED display: ●...OFF, ☀...ON, ⦿...Blinking

(*)How to distinguish the master unit, sub unit 1, and sub unit 2 in the multi system.

Method 1: By the H8P (MULTI) LED display

☀ (ON): Master unit	⦿ (Blinking): Sub unit 1	● (OFF): Sub unit 2
---------------------	--------------------------	---------------------

Method 2: By the transmission wiring to indoor unit

Transmission wiring is connected: Master unit
Transmission wiring is not connected : Sub unit 1 or Sub unit 2

STEP4 Make the onsite settings as needed using the push button (BS1-BS5) on the outdoor unit PC-board (A1P) with the power on. (See “4.4.2 Field Setting from Outdoor Unit.”)

STEP5 Perform the check operation following the Check Operation Method of the [Service Precautions] label on the EL. COMPO. BOX lid. The system operation for about 40 minutes and automatically stops the check operation.

If the malfunction code is not displayed in the remote control after the system stop, check operation is completed. Normal operation will be possible after 5 minutes. If the malfunction code is displayed in the remote control, correct the malfunction following [remote control displays malfunction code] and perform the check operation again.



Note1: Onsite Settings with the Power Off

If the COOL/HEAT selector was connected to the outdoor unit set the dip switch (DS1) on the outdoor unit PC-board (A1P) to “ON” (it is set to “OFF” when shipped from the factory). For the position of the dip switch (DS1), see the “Service Precautions” label (see at right) which is attached to the EL. COMPO. BOX lid.

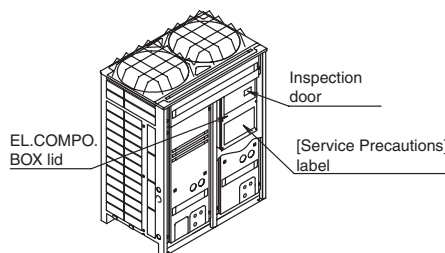

[remote control displays malfunction code]

Malfunction code	Installation error	Remedial action
E3, E4 F3, F6 UF	The shutoff valve of the outdoor unit is left closed.	Open the shutoff valve.
U1	The phases of the power to the outdoor unit is reversed.	Exchange two of the three phases (L1, L2, L3) to make a proper connection.
U1 U4 LC	No power is supplied to an outdoor or indoor unit (including phase interruption).	Make sure the power source wire is properly connected to the outdoor unit and revise if necessary.
UF	There is conflict on the connection of transmission wiring in the system.	Check if the refrigerant piping line and the transmission wiring are consistent with each other.
E3 F6 UF	Refrigerant overcharge.	Recalculate the additional amount refrigerant from the piping length and correct the refrigerant charge level by recovering any excessive refrigerant with a refrigerant recovery machine.
E4 F3	Insufficient refrigerant.	<ul style="list-style-type: none"> • Check if the additional refrigerant charge has been finished correctly. • Recalculate the additional amount refrigerant from the piping length and add the adequate amount.
U7, U4 UF, UH	If the outdoor unit terminal is connected when there is one outdoor unit installed.	Remove the line from the outdoor multi terminals (Q1 and Q2).

If any malfunction codes other than the above are displayed, check the service manual for how to respond.

4.2 Operation when Power is Turned On

4.2.1 When Turning On Power First Time

The unit cannot be run for up to 12 minutes to automatically set the master power and address (indoor-outdoor address, etc.).

Status

Outdoor unit

Test lamp H2P Blinks
Can also be set during operation described above.

Indoor unit

If ON button is pushed during operation described above, the "UH" malfunction indicator blinks.
(Returns to normal when automatic setting is complete.)

4.2.2 When Turning On Power the Second Time and Subsequent

Tap the RESET button on the outdoor unit PC board. Operation becomes possible for about 2 minutes. If you do not push the RESET button, the unit cannot be run for up to 10 minutes to automatically set master power.

Status

Outdoor unit

Test lamp H2P Blinks
Can also be set during operation described above.

Indoor unit

If ON button is pushed during operation described above, the operation lamp lights but the compressor does not operate. (Returns to normal when automatic setting is complete.)

4.2.3 When an Indoor Unit or Outdoor Unit has been Added, or Indoor or Outdoor Unit PC Board has been Changed

Be sure to push and hold the RESET button for 5 seconds. If not, the addition cannot be recognized. In this case, the unit cannot be run for up to 12 minutes to automatically set the address (indoor-outdoor address, etc.)

Status

Outdoor unit

Test lamp H2P ON
Can also be set during operation described above.

Indoor unit

If ON button is pushed during operation described above, the "UH" or "U4" malfunction indicator blinks. (Returns to normal when automatic setting is complete.)

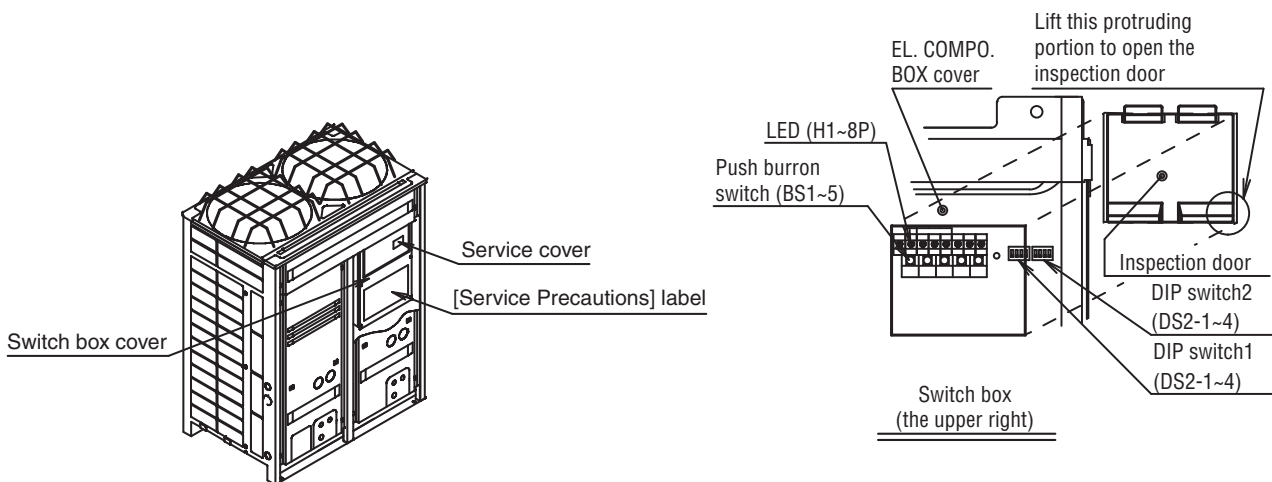

Caution When the 400 volt power supply is applied to "N" phase by mistake, replace Inverter P.C.B (A2P) and control transformer (T1R, T2R) in switch box together.

4.3 Outdoor Unit PC Board Layout

Outdoor unit PC board

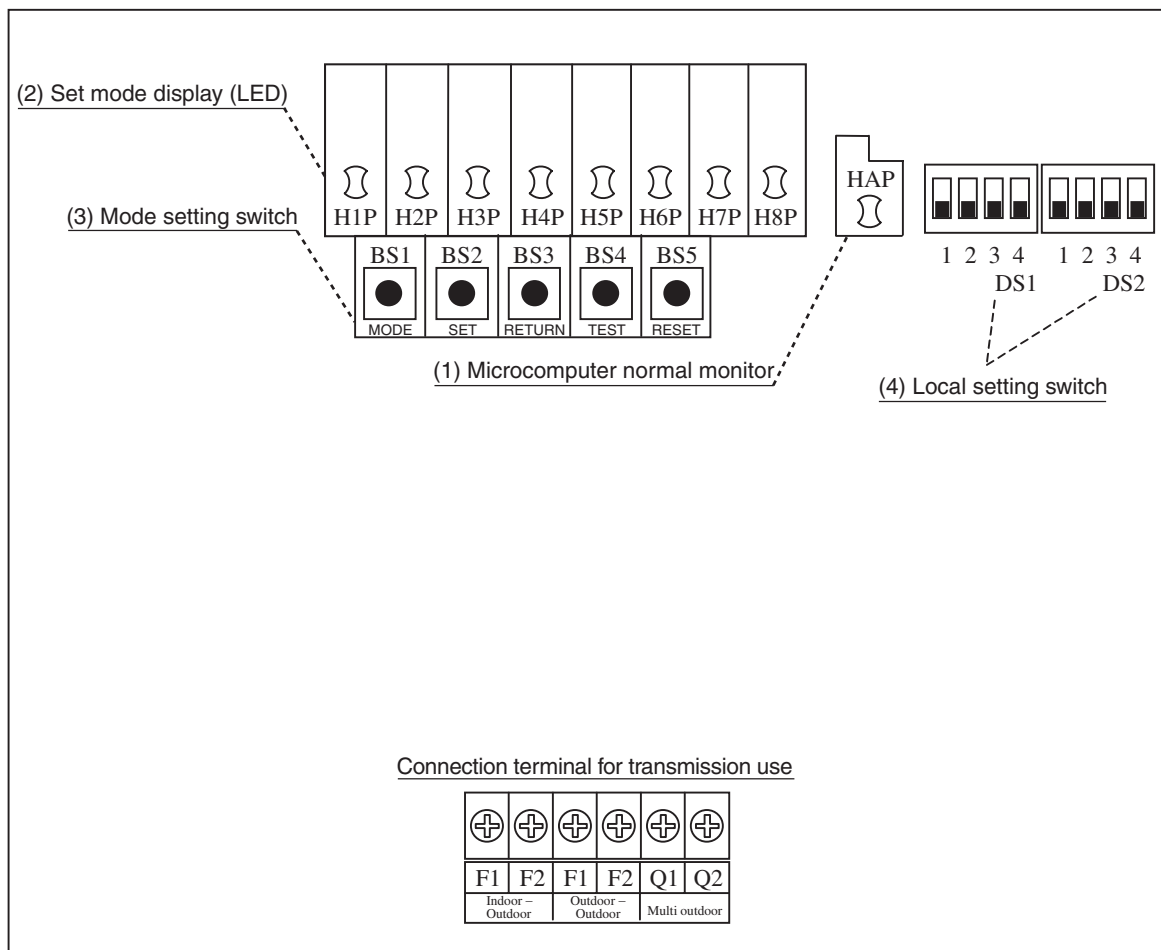

(V3054)

- (1) Microcomputer normal monitor.
This monitor blinks while in normal operation, and turns on or off when a malfunction occurs.
- (2) Set mode display (LED).
LEDs display mode according to the setting.
- (3) Mode setting switch Used to change mode.
- (4) Local setting switch.
Used to make field settings.

4.4 Field Setting

4.4.1 Field Setting from Remote Control

Individual function of indoor unit can be changed from the remote control. At the time of installation or after service inspection / repair, make the local setting in accordance with the following description.





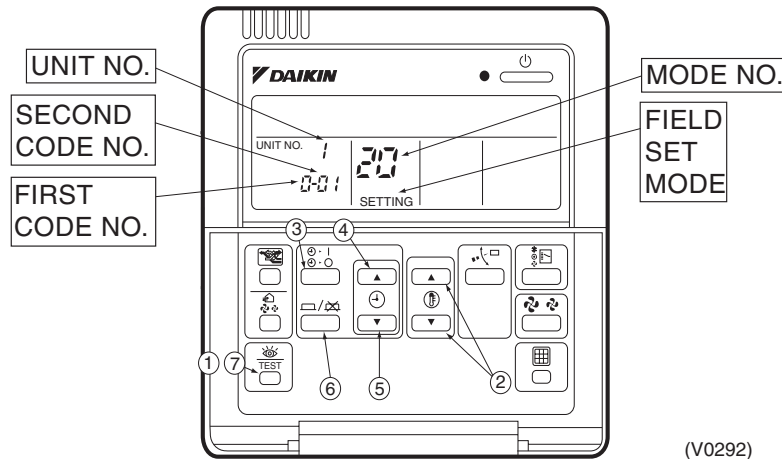

Wrong setting may cause malfunction.

(When optional accessory is mounted on the indoor unit, setting for the indoor unit may be required to change. Refer to information in the option handbook.)

4.4.1.1 Wired Remote Control <BRC1C61, 62>



(V0292)

1. When in the normal mode, press the “” button for a minimum of four seconds, and the FIELD SET MODE is entered.
2. Select the desired MODE NO. with the “” button (②).
3. During group control, when setting by each indoor unit (mode No. 20, 22 and 23 have been selected), push the “” button (③) and select the INDOOR UNIT NO to be set. (This operation is unnecessary when setting by group.)
4. Push the “” upper button (④) and select FIRST CODE NO.
5. Push the “” lower button (⑤) and select the SECOND CODE NO.
6. Push the “” button (⑥) once and the present settings are SET.
7. Push the “” button (⑦) to return to the NORMAL MODE.

(Example)





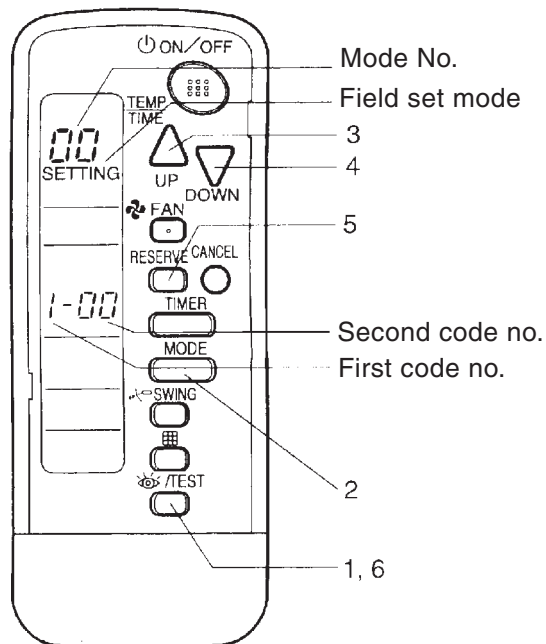

If during group setting and the time to clean air filter is set to FILTER CONTAMINATION, HEAVY, SET MODE NO. to “10” FIRST CODE NO. to “0”, and SECOND CODE NO. to “02”.

4.4.1.2 Infrared Remote Control - Indoor Unit

BRC7C type
BRC7E type
BRC4C type



(V2770)

1. When in the normal mode, push the “ ” button for 4 seconds or more, and operation then enters the “field set mode.”
2. Select the desired “mode No.” with the “ ” button.
3. Pushing the “ ” button, select the first code No.
4. Pushing the “ ” button, select the second code No.
5. Push the timer “ ” button and check the settings.
6. Push the “ ” button to return to the normal mode.

(Example)

When setting the filter sign time to “Filter Dirtiness-High” in all group unit setting, set the Mode No. to “10”, Mode setting No. to “0” and setting position No. to “02”.

4.4.1.3 Simplified Remote Control

BRC2A51
BRC2C51

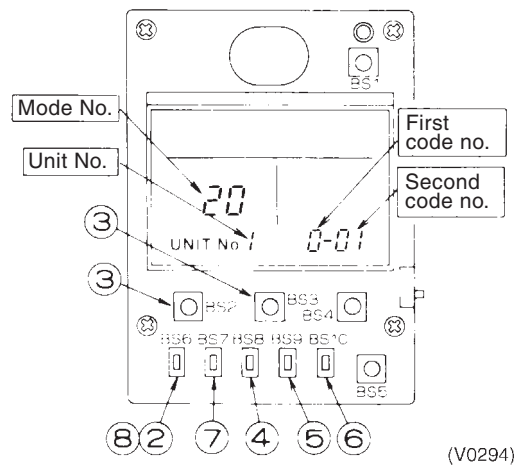

1. Remove the upper part of remote control.
2. When in the normal mode, press the [BS6] BUTTON (②) (field set), and the FIELD SET MODE is entered.
3. Select the desired MODE No. with the [BS2] BUTTON (③) (temperature setting ▲) and the [BS3] BUTTON (③) (temperature setting ▼).
4. During group control, when setting by each indoor unit (mode No. 20, 22, and 23 have been selected), push the [BS8] (④) BUTTON (unit No.) and select the INDOOR UNIT NO. to be set. (This operation is unnecessary when setting by group.)
5. Push the [BS9] BUTTON (⑤) (set A) and select FIRST CODE NO.
6. Push the [BS10] BUTTON (⑥) (set B) and select SECOND CODE NO.
7. Push the [BS7] BUTTON (⑦) (set/cancel) once and the present settings are SET.
8. Push the [BS6] BUTTON (⑧) (field set) to return to the NORMAL MODE.
9. (Example) If during group setting and the time to clean air filter is set to FILTER CONTAMINATION - HEAVY, SET MODE NO. to "10", FIRST CODE NO. to "0", and SECOND CODE NO. to "02".

4.4.1.4 Setting Contents and Code No. – VRV Indoor unit

VRV system indoor unit settings	Mode No. Note 2	Setting Switch No.	Setting Contents	Second Code No.(Note 3)								
				01		02		03		04		
10(20)	0		Filter contamination heavy/light (Setting for display time to clean air filter) (Sets display time to clean air filter to half when there is heavy filter contamination.)	Super long life filter	Light	Approx. 10,000 hrs.	Heavy	Approx. 5,000 hrs.	—		—	
				Long life filter		Approx. 2,500 hrs.		Approx. 1,250 hrs.				
				Standard filter		Approx. 200 hrs.		Approx. 100 hrs.				
	1		Long life filter type	Long life filter		Super long life filter		—		—		
	2		Thermostat sensor in remote control	Use		No use		—				
	3		Display time to clean air filter calculation (Set when filter sign is not to be displayed.)	Display		No display		—				
12(22)	0		Optional accessories output selection (field selection of output for adapter for wiring)	Indoor unit turned ON by thermostat				Operation output		Malfunction output		
	1		ON/OFF input from outside (Set when ON/OFF is to be controlled from outside.)	Forced OFF		ON/OFF control		External protection device input		—		
	2		Thermostat differential changeover (Set when remote sensor is to be used.)	1°C		0.5°C		—		—		
	3		OFF by thermostat fan speed	LL		Set fan speed		—		—		
	4		Automatic mode differential (automatic temperature differential setting for VRV system heat recovery series cool/heat)	01:0	02:1	03:2	04:3	05:4	06:5	07:6	08:7	
	5		Power failure automatic reset	Not equipped		Equipped		—		—		
13(23)	0		High air outlet velocity (Set when installed in place with ceiling higher than 2.7 m.)	N		H		S		—		
	1		Selection of air flow direction (Set when a blocking pad kit has been installed.)	F (4 directions)		T (3 directions)		W (2 directions)		—		
	3		Air flow direction adjustment (Set at installation of decoration panel.)	Equipped		Not equipped				—		
	4		Field set air flow position setting	Draft prevention		Standard		Ceiling Soiling prevention		—		
	5		Field set fan speed selection (fan speed control by air discharge outlet for phase control)	Standard		Optional accessory 1		Optional accessory 2		—		
15(25)	1		Thermostat OFF excess humidity	Not equipped		Equipped		—		—		
	2		Direct duct connection (when the indoor unit and heat reclaim ventilation unit are connected by duct directly.) *Note 6	Not equipped		Equipped		—		—		
	3		Drain pump humidifier interlock selection	Not equipped		Equipped		—		—		
	5		Field set selection for individual ventilation setting by remote control	Not equipped		Equipped		—		—		
	6		Field set selection for individual ventilation setting by remote control	Not equipped		Equipped		—		—		



- Notes:**
- Settings are made simultaneously for the entire group, however, if you select the mode No. inside parentheses, you can also set by each individual unit. Setting changes however cannot be checked except in the individual mode for those in parentheses.
 - The mode numbers inside parentheses cannot be used by infrared remote controls, so they cannot be set individually. Setting changes also cannot be checked.
 - Marked are factory set.
 - Do not make settings other than those described above. Nothing is displayed for functions the indoor unit is not equipped with.
 - “88” may be displayed to indicate the remote control is resetting when returning to the normal mode.
 - If the setting mode to “Equipped”, heat reclaim ventilation fan conducts the fan residual operation by linking to indoor unit.

4.4.1.5 Applicable range of Field setting

	Ceiling mounted cassette type			Slim Ceiling mounted duct type	Ceiling mounted built-in type	Ceiling mounted duct type	Ceiling suspended type	Wall mounted type	Floor standing type	Concealed Floor standing type	New Ceiling suspended cassette type	Outdoor air processing unit
	Multi flow	Double flow	Corner type									
	FXFQ	FXCQ	FXKQ									
Filter sign	○	○	○	○	○	○	○	○	○	○	○	○
Ultra long life filter sign	○	○	—	—	—	—	—	—	—	—	—	—
remote control thermostat sensor	○	○	○	○	○	○	○	○	○	○	○	—
Set fan speed when thermostat OFF	○	○	○	○	○	○	○	○	○	○	○	—
Air flow adjustment Ceiling height	○	—	—	—	—	—	○	—	—	—	○	—
Air flow direction	○	—	—	—	—	—	—	—	—	—	○	—
Air flow direction adjustment (Down flow operation)	—	—	○	—	—	—	—	—	—	—	—	—
Air flow direction adjustment range	○	○	○	—	—	—	—	—	—	—	—	—
Field set fan speed selection	○	—	—	○*1	—	—	○	—	—	—	—	—
Discharge air temp. (Cooling)	—	—	—	—	—	—	—	—	—	—	—	○
Discharge air temp. (Heating)	—	—	—	—	—	—	—	—	—	—	—	○

*1 Static pressure selection

4.4.1.6 Detailed Explanation of Setting Modes

Filter Sign Setting

If switching the filter sign ON time, set as given in the table below.

Set Time

Setting	Filter Specs.	Standard	Long Life	Ultra Long Life Filter
Contamination Light		200 hrs.	2,500 hrs.	10,000 hrs.
Contamination Heavy		100 hrs.	1,250 hrs.	5,000 hrs.

Ultra-Long-Life Filter Sign Setting

When a Ultra-long-life filter is installed, the filter sign timer setting must be changed.

Setting Table

Mode No.	Setting Switch No.	Setting Position No.	Setting
10 (20)	1	01	Long-Life Filter
		02	Ultra-Long-Life Filter (1)
		03	—

External ON/OFF input

This input is used for "ON / OFF operation" and "Protection device input" from the outside. The input is performed from the T1-T1 terminal of the operation terminal block (X1A) in the electric component box.

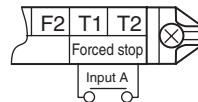

Setting Table

Mode No.	Setting Switch No.	Setting Position No.	Operation by input of the signal A
12 (22)	1	01	ON: Forced stop (prohibition of using the remote control) OFF: Permission of using the remote control
		02	OFF → ON: Permission of operation ON → OFF: Stop
		03	ON: Operation OFF: The system stops, then the applicable unit indicates "A0". The other indoor units indicate "U9".

Fan Speed Changeover When Thermostat is OFF

By setting to "Set Fan Speed," you can switch the fan speed to the set fan speed when the heating thermostat is OFF.

* Since there is concern about draft if using "fan speed up when thermostat is OFF," you should take the setup location into consideration.

Setting Table

Mode No.	First Code No.	Second Code No.	Setting
12(22)	3	01	LL Fan Speed
		02	Set Fan Speed

Auto Restart after Power Failure Reset

For the air conditioners with no setting for the function (same as factory setting), the units will be left in the stop condition when the power supply is reset automatically after power failure reset or the main power supply is turned on again after once turned off. However, for the air conditioners with the setting, the units may start automatically after power failure reset or the main power supply turned on again (return to the same operation condition as that of before power failure).

For the above reasons, when the unit is set enabling to utilize “Auto restart function after power failure reset”, utmost care should be paid for the occurrence of the following situation.



- Caution**
- 1. The air conditioner starts operation suddenly after power failure reset or the main power supply turned on again. Consequently, the user might be surprised (with question for the reason why).**
 - 2. In the service work, for example, turning off the main power switch during the unit is in operation, and turning on the switch again after the work is completed start the unit operation (the fan rotates).**

Air Flow Adjustment - Ceiling height

Make the following setting according to the ceiling height. The setting position No. is set to “01” at the factory.

■ In the Case of FXAQ, FXHQ

Mode No.	Setting Switch No.	Setting Position No.	Setting
13(23)	0	01	Wall-mounted type: Standard
		02	Wall-mounted type: Slight increase
		03	Wall-mounted type: Normal increase

■ In the Case of FXFQ25~80

Mode No.	First code No.	Second code No.	Setting	Ceiling height		
				4-way Outlets	3-way Outlets	2-way Outlets
13 (23)	0	01	Standard (N)	Lower than 2.7 m	Lower than 3.0 m	Lower than 3.5 m
		02	High Ceiling (H)	Lower than 3.0 m	Lower than 3.3 m	Lower than 3.8 m
		03	Higher Ceiling (S)	Lower than 3.5 m	Lower than 3.5 m	—

■ In the Case of FXFQ100~125

Mode No.	First code No.	Second code No.	Setting	Ceiling height		
				4-way Outlets	3-way Outlets	2-way Outlets
13 (23)	0	01	Standard (N)	Lower than 3.2 m	Lower than 3.6 m	Lower than 4.2 m
		02	High Ceiling (H)	Lower than 3.6 m	Lower than 4.0 m	Lower than 4.2 m
		03	Higher Ceiling (S)	Lower than 4.2 m	Lower than 4.2 m	—

■ In the Case of FXUQ71~125

Mode No.	First code No.	Second code No.	Setting	Ceiling height		
				4-way Outlets	3-way Outlets	2-way Outlets
13 (23)	0	01	Standard (N)	Lower than 2.7 m	Lower than 3.0 m	Lower than 3.5 m
		02	High Ceiling (H)	Lower than 3.0 m	Lower than 3.5 m	Lower than 3.8 m
		03	Higher Ceiling (S)	Lower than 3.5 m	Lower than 3.8 m	—

Air Flow Direction Setting

Set the air flow direction of indoor units as given in the table below. (Set when optional air outlet blocking pad has been installed.) The second code No. is factory set to "01."

Setting Table

Mode No.	First Code No.	Second Code No.	Setting
13 (23)	1	01	F : 4-direction air flow
		02	T : 3-direction air flow
		03	W : 2-direction air flow

Setting of Air Flow Direction Adjustment

Only the model FXKQ has the function.

When only the front-flow is used, sets yes/no of the swing flap operation of down-flow.

Setting Table

Setting	Mode No.	First Code No.	Second Code No.
Down-flow operation: Yes	13 (23)	3	01
Down-flow operation: No			02

Setting of Air Flow Direction Adjustment Range

Make the following air flow direction setting according to the respective purpose.

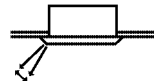

(S2537)

Setting Table

Mode No.	First Code No.	Second Code No.	Setting
13 (23)	4	01	Upward (Draft prevention)
		02	Standard
		03	Downward (Ceiling soiling prevention)

Air flow rate switching at discharge grille for field air flow rate switching

When the optional parts (high performance filter, etc.) is installed, sets to change fan speed for securing air flow rate.

Follow the instruction manual for the optional parts to enter the setting numbers.

Setting of the static pressure selection (for FXDQ model)

Model No.	First Code No.	Second Code No.	External static pressure
13 (23)	5	01	Standard (15Pa)
		02	High static pressure (44Pa)

4.4.1.7 Outdoor Air Processing Unit-Field Setting (Remote Control)

Mode No.	Setting SW No.	Setting contents	Setting position No.														
			01	02	03	04	05	06	07	08	09	10	11	12	13	14	15
10 (20)	0	Stain of filter	2500hr	1250hr	—	—	—	—	—	—	—	—	—	—	—	—	
	3	Filtering time cumulation	Display	No display	—	—	—	—	—	—	—	—	—	—	—	—	
12 (22)	1	External ON/OFF input	Forced stop	ON-OFF control	—	—	—	—	—	—	—	—	—	—	—		
	5	Power failure automatic reset	Not equipped	Equipped	—	—	—	—	—	—	—	—	—	—	—		
14 (24)	3	Discharge temperature (cooling)	13°C	14	15	16	17	18	19	20	21	22	23	24	25	25	25
	4	Discharge temperature (heating)	18°C	19	20	21	22	23	24	25	26	27	28	29	30	30	30

Note) Bold face in indicates the default setting.

4.4.1.8 Centralized Control Group No. Setting

BRC1A Type

In order to conduct the central remote control using the central remote control and the unified ON/OFF controller, Group No. settings should be made by group using the operating remote control.

Make Group No. settings for central remote control using the operating remote control.

1. While in normal mode, press and hold the “ ” switch for a period of four seconds or more to set the system to “Field Setting Mode”.
2. Select the MODE No. “00” with the “ ” button.
3. Use the “ ” button to select the group No. for each group.
(Group numbers increase in the order of 1-00, 1-01, ... 1-15, 2-00, ... 4-15.)
4. Press “ ” to set the selected group No.
5. Press “ ” to return to the NORMAL MODE.

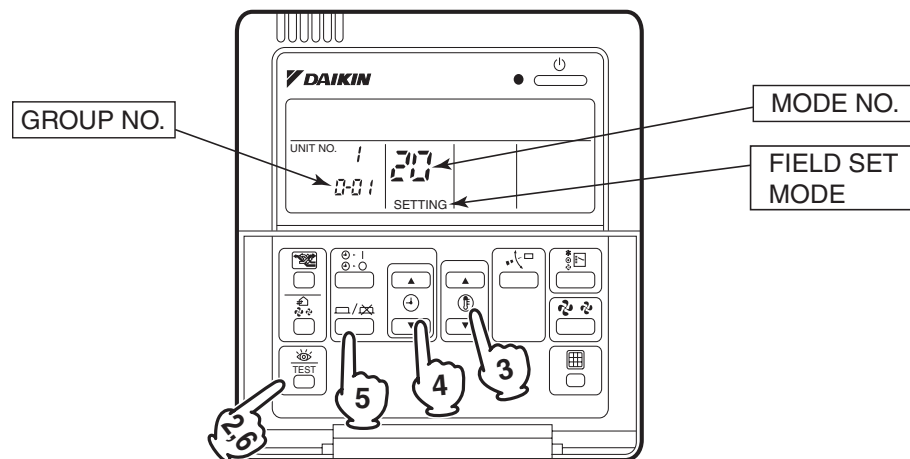







Note:

- For infrared remote control, see the following.
- For setting group No. of HRV and wiring adapter for other air conditioners, etc., refer to the instruction manual attached.

NOTICE

Enter the group No. and installation place of the indoor unit into the attached installation table. Be sure to keep the installation table with the operation manual for maintenance.

**BRC7C Type
BRC7E Type
BRC4C Type**

- Group No. setting by infrared remote control for centralized control
- 1. When in the normal mode, push “/TEST” button for 4 seconds or more, and operation then enters the “field set mode.”
- 2. Set mode No. “00” with “” button.
- 3. Set the group No. for each group with “” “” button (advance/backward).
- 4. Enter the selected group numbers by pushing “” button.
- 5. Push “” button and return to the normal mode.

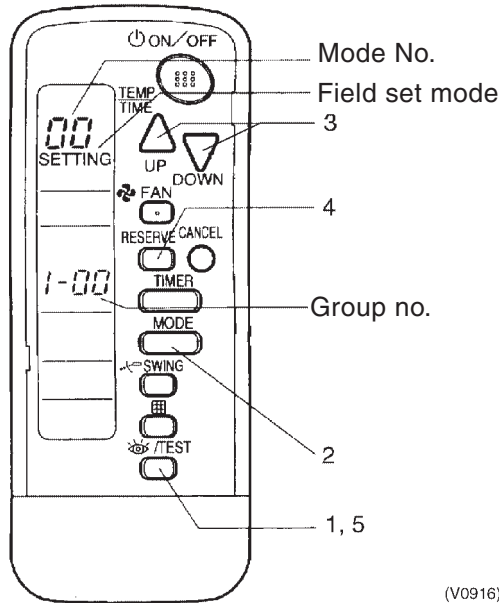

Group No. Setting Example

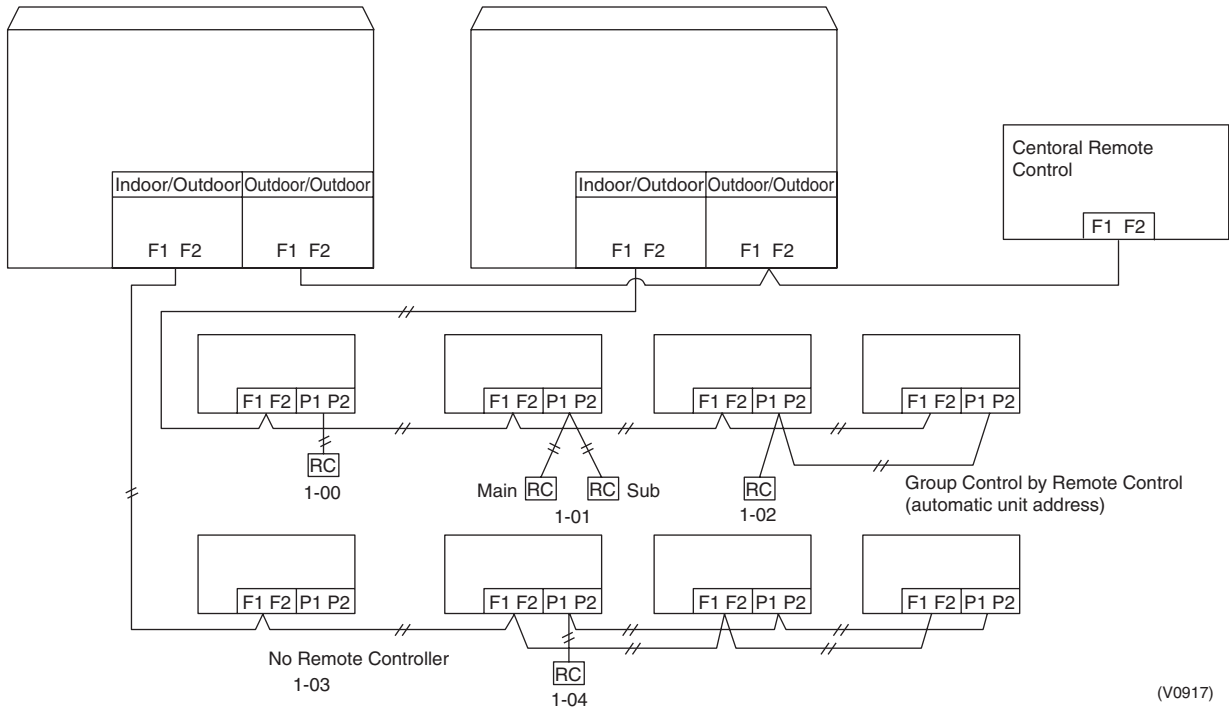

Caution When turning the power supply on, the unit may often not accept any operation while "88" is displaying after all indications were displayed once for about 1 minute on the liquid crystal display. This is not an operative fault.

4.4.1.9 Setting of Operation Control Mode from Remote Control (Local Setting)

The operation control mode is compatible with a variety of controls and operations by limiting the functions of the operation remote control. Furthermore, operations such as remote control ON/OFF can be limited in accordance with the combination conditions. (Refer to information in the table below.)

Central remote control is normally available for operations. (Except when centralized monitor is connected)

4.4.1.10 Contents of Control Modes

Twenty modes consisting of combinations of the following five operation modes with temperature and operation mode setting by remote control can be set and displayed by operation modes 0 through 19.

- ◆ ON/OFF control impossible by remote control
Used when you want to turn on/off by central remote control only.
(Cannot be turned on/off by remote control.)
- ◆ OFF control only possible by remote control
Used when you want to turn on by central remote control only, and off by remote control only.
- ◆ Centralized
Used when you want to turn on by central remote control only, and turn on/off freely by remote control during set time.
- ◆ Individual
Used when you want to turn on/off by both central remote control and remote control.
- ◆ Timer operation possible by remote control
Used when you want to turn on/off by remote control during set time and you do not want to start operation by central remote control when time of system start is programmed.

How to Select Operation Mode

Whether operation by remote control will be possible or not for turning on/off, controlling temperature or setting operation mode is selected and decided by the operation mode given on the right edge of the table below.

Example

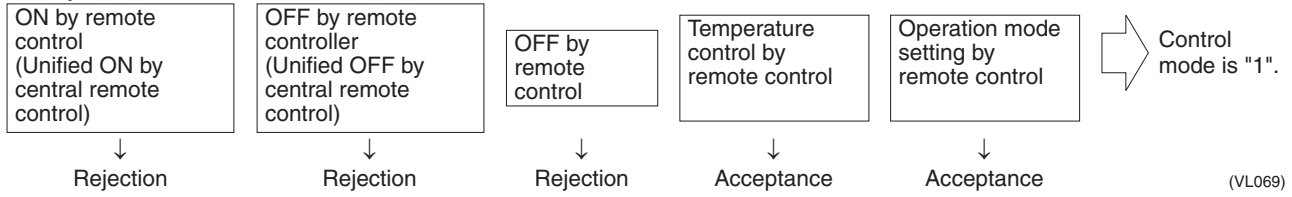

Control mode	Control by remote control					Control mode
	Operation		OFF	Temperature control	Operation mode setting	
	Unified operation, individual operation by central remote control, or operation controlled by timer	Unified OFF, individual stop by central remote control, or timer stop				
ON/OFF control impossible by remote control	Rejection (Example)	Rejection (Example)	Rejection (Example)	Rejection	Acceptance	0
OFF control only possible by remote control				Acceptance (Example)	Acceptance (Example)	1(Example)
Centralized	Acceptance	Acceptance	Acceptance	Rejection	Acceptance	2
Individual				Acceptance	Rejection	Rejection
Timer operation possible by remote control	Acceptance (During timer at ON position only)	Acceptance (During timer at ON position only)	Acceptance	Acceptance	Acceptance	3
				Rejection	Rejection	13
				Rejection	Acceptance	4
				Acceptance	Rejection	14
				Rejection	Acceptance	5
				Acceptance	Rejection	15
				Rejection	Acceptance	6
				Acceptance	Rejection	16
				Acceptance	Acceptance	7 *1
				Rejection	Rejection	17
				Rejection	Acceptance	8
				Acceptance	Rejection	18
				Acceptance	Acceptance	9
				Rejection	Rejection	19

Do not select "timer operation possible by remote control" if not using a remote control. Operation by timer is impossible in this case.

*1. Factory setting

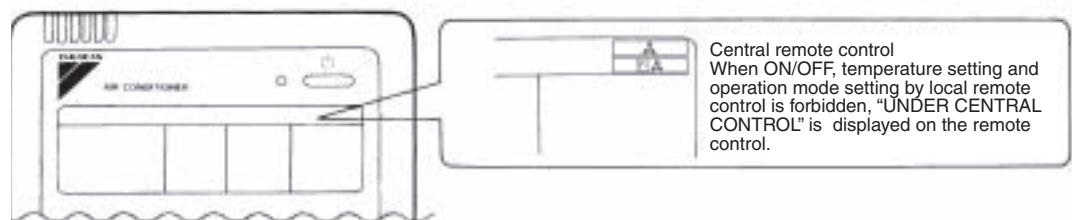

4.4.2 Field Setting from Outdoor Unit

4.4.2.1 Field Setting from Outdoor Unit

■ List of Field Setting Items

This following section indicates the list of field setting items. For the lists of dip switch contents, Setting mode 1, and Setting mode 2, refer to information in tables shown on the following page onward.

For setting items of (*1), refer to detailed information provided on page 111 onward.

Setting item		Content and objective of setting	Overview of setting procedure	
Function setting	1	Setting of COOL/HEAT selection (*1) *Heat Pump model only	<ul style="list-style-type: none"> ■ COOL/HEAT selection methods are selectable from the following <ol style="list-style-type: none"> (1) Control by each outdoor unit using the indoor unit remote control (2) Control by each outdoor unit using the COOL/HEAT selection remote control (3) Batch control by outdoor unit group using the indoor unit remote control (4) Batch control by outdoor unit group using the COOL/HEAT selection remote control 	<ul style="list-style-type: none"> ■ In order to use the COOL/HEAT selection remote control, set the DS1-1 on the outdoor unit PC board to OUT. ■ For outdoor unit group control, set the system to "BATCH MASTER" or "SLAVE" while in "Setting mode 1". Then, make setting of COOL/HEAT batch address.
	2	Setting of low noise operation (*1)	A. Use external input to step down the upper limit of the fan (factory set to Step 8), providing low noise level. <ol style="list-style-type: none"> (1) Mode 1: Step 6 or lower (2) Mode 2: Step 5 or lower (3) Mode 3: Step 4 or lower 	<ul style="list-style-type: none"> ■ Use the "External control adapter for outdoor unit". Set to "External control adapter for outdoor unit" with No. 12 of "Setting mode 2" and select the mode with No. 25. If necessary, set the "Capacity priority setting" to ON with No. 29.
			B. The low noise operation aforementioned is enabled in nighttime automatic low noise operation mode. Start time: Selectable in the range of 20:00 to 24:00 hours. End time: Selectable in the range of 06:00 to 08:00 hours. (Use the said time as a guide since the start time and the end time are estimated according to outdoor temperatures.)	<ul style="list-style-type: none"> ■ Make this setting while in "Setting mode 2". Select a mode with No. 22 of "Setting mode 2". Select the start time with No. 26 and the end time with No. 27. If necessary, set the "Capacity priority setting" to ON with No. 29.
	3	Setting of demand operation (*1)	<ul style="list-style-type: none"> ■ Used to place limits on the compressor operating frequency to control the upper limit of power consumption. <ol style="list-style-type: none"> (1) Mode 1 of Demand 1: 60% or less of rating (2) Mode 2 of Demand 1: 70% or less of rating (3) Mode 3 of Demand 1: 80% or less of rating (4) Demand 2: 40% or less of rating 	<ul style="list-style-type: none"> ■ For setting with the use of "external control adapter": Set the system to "External control adapter for outdoor unit" with No. 12 of Setting mode 2" and select the mode with No. 30. ■ For setting only in "Setting mode 2": Set the system to Constant demand mode with No. 32 of "Setting mode 2" and select the mode with No. 30.
	4	Setting of AirNet address	<ul style="list-style-type: none"> ■ Used to make address setting with AirNet connected. 	<ul style="list-style-type: none"> ■ Set the AirNet to an intended address using binary numbers with No. 13 of "Setting mode 2".
	5	Setting of hot water heater	<ul style="list-style-type: none"> ■ Make this setting to conduct heating operation using the hot water heater. 	<ul style="list-style-type: none"> ■ Set No. 16 of "Setting mode 2" to ON.
6	Setting of high static pressure	<ul style="list-style-type: none"> ■ Make this setting to operate a system with diffuser duct while in high static pressure mode. (Use this setting mode when shields are installed on upper floors or balconies.) <p>* In order to mount the diffuser duct, remove the cover from the outdoor unit fan.</p>	<ul style="list-style-type: none"> ■ Set No. 18 of "Setting mode 2" to ON. 	

Setting item		Content and objective of setting	Overview of setting procedure	
Service setting	1	Indoor unit fan forced H operation	<ul style="list-style-type: none"> Used to operate the indoor unit in the stopped state in forced H operation mode. 	<ul style="list-style-type: none"> Set No. 5 of "Setting mode 2" to indoor unit forced fan H.
	2	Indoor unit forced operation	<ul style="list-style-type: none"> Used to operate the indoor unit in forced operation mode. 	<ul style="list-style-type: none"> Set No. 6 of "Setting mode 2" to indoor unit forced operation mode.
	3	Change of targeted evaporating temperature (in cooling)	<ul style="list-style-type: none"> In cooling operation, used to change the targeted evaporating temperature for compressor capacity control. 	<ul style="list-style-type: none"> Select high side or low side with No. 8 of "Setting mode 2".
	4	Change of targeted condensing temperature (in heating)	<ul style="list-style-type: none"> In heating operation, used to change the targeted condensing temperature for compressor capacity control. 	<ul style="list-style-type: none"> Select high side or low side with No. 9 of "Setting mode 2".
	5	Setting of defrost selection *Heat Pump model only	<ul style="list-style-type: none"> Used to change a temperature at which the defrost operation is initiated, thus making the initiation easy or hard. 	<ul style="list-style-type: none"> Select fast side or slow side with No. 10 of "Setting mode 2".
	6	Setting of sequential startup	<ul style="list-style-type: none"> Used to start units not in sequence but simultaneously. 	<ul style="list-style-type: none"> Set No. 11 of "Setting mode 2" to NONE.
	7	Emergency operation	<ul style="list-style-type: none"> If the compressor has a failure, used to prohibit the operation of compressor(s) concerned or outdoor unit(s) concerned and to conduct emergency operation of the system only with operable compressor(s) or outdoor unit(s). 	<ul style="list-style-type: none"> Make this setting while in "Setting mode 2". For system with a single outdoor unit: Set with No. 19 or 42. For system with multiple outdoor units: Set with No. 38, 39, or 40.
	8	Additional refrigerant charging (*1)	<ul style="list-style-type: none"> If a necessary amount of refrigerant cannot be charged due to the stop of outdoor unit, operate the outdoor unit and then refill refrigerant. 	<ul style="list-style-type: none"> Set No. 20 of "Setting mode 2" to ON and then charge refrigerant.
	9	Refrigerant recovery mode (*1)	<ul style="list-style-type: none"> Used to recover refrigerant on site. With operations of indoor and outdoor units prohibited, fully open the expansion valve of the indoor and outdoor units. 	<ul style="list-style-type: none"> Set No. 21 of "Setting mode 2" to ON.
	10	Vacuuming mode (*1)	<ul style="list-style-type: none"> Used to conduct vacuuming on site. Fully open the expansion valves of the indoor and outdoor units, and energize part of solenoid valves. Use a vacuum pump to conduct vacuuming. 	<ul style="list-style-type: none"> Set No. 21 of "Setting mode 2" to ON.
	11	ENECUT test operation	<ul style="list-style-type: none"> Used to forcedly turn ON the ENECUT. (Be noted this mode is not functional with the indoor unit remote control turned ON.) 	<ul style="list-style-type: none"> Set No. 24 of "Setting mode 2" to ON.
	12	Power transistor check mode	<ul style="list-style-type: none"> Used for the troubleshooting of DC compressors. Inverter waveform output makes it possible to judge whether a malfunction results from the compressor or the PC board. 	<ul style="list-style-type: none"> Set No. 28 of "Setting mode 2" to ON.
	13	Setting of model with spare PC board	<ul style="list-style-type: none"> In order to replace the PC board by a spare one, be sure to make model setting. 	<ul style="list-style-type: none"> For this setting, set the DS2-2, -3, and-4 switches on the PC board to the model concerned.

For setting items of (*1), refer to detailed information provided on page 112 onward.

■ Setting by dip switches

Using dip switches on the PC board enables field setting shown below. However, make no changes of factory settings except for DS1-1.

Dipswitch		Setting item	Description
No.	Setting		
DS1-1	ON	Cool / Heat select	Used to set cool / heat select by Cool/Heat selector equipped with outdoor unit. • Heat Pump model only
	OFF (Factory set)		
DS1-2 ~DS1-4	ON	Not used	Do not change the factory settings.
	OFF (Factory set)		
DS2-1 ~4	ON	Not used	Do not change the factory settings.
	OFF (Factory set)		

■ **Setting by pushbutton switches**

The following settings are made by pushbutton switches on PC board.
 In case of multi-outdoor unit system, various items should be set with the master unit.
 (Setting with the slave unit is disabled.)

The master unit and slave unit can be discriminated with the LED display as shown below.

LED display

		MODE H1P	TEST H2P	COOL/HEAT select			Low noise H6P	Demand H7P	Multi; H8P
				IND H3P	MASTER H4P	SLAVE H5P			
Single-outdoor-unit system		●	●	○	●	●	●	●	●
Outdoor-multi system	Master	●	●	○	●	●	●	●	○
	Slave 1	●	●	●	●	●	●	●	◐
	Slave 2	●	●	●	●	●	●	●	●

(Factory setting)

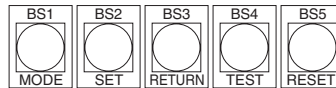

(V2760)

There are the following three setting modes.

① **Setting mode 1 (H1P off)**

Initial status (when normal) : Used to select the cool/heat setting. Also indicates during “abnormal”, “low noise control” and “demand control”.

② **Setting mode 2 (H1P on)**

Used to modify the operating status and to set program addresses, etc. Usually used in servicing the system.

③ **Monitor mode (H1P blinks)**

Used to check the program made in Setting mode 2.

■ **Mode changing procedure 1**

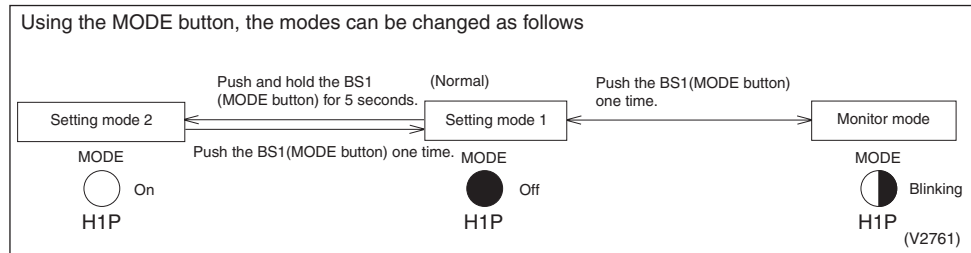

■ **Mode changing procedure 2**

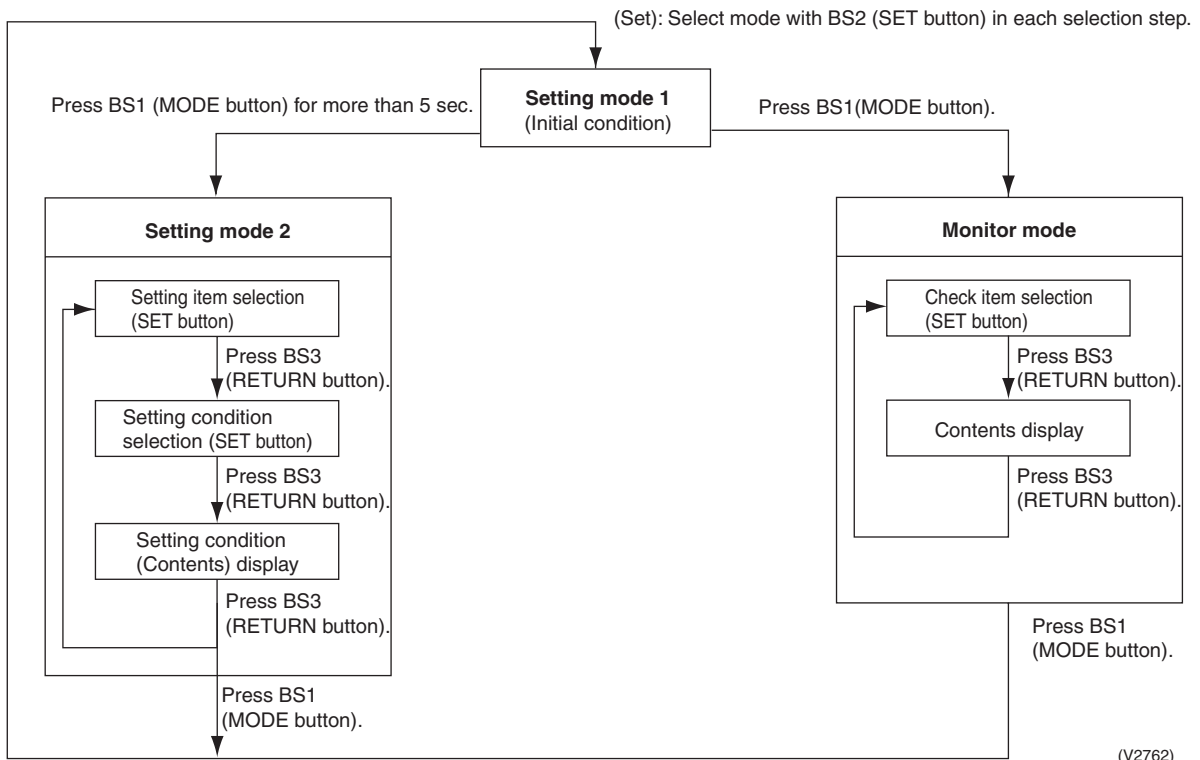

(V2762)

a. "Setting mode 1"

This mode is used to set and check the following items.

1. Set items In order to make COOL/HEAT selection in a batch of outdoor unit group, change the setting.
 - COOL/HEAT selection (IND) Used to select COOL or HEAT by individual outdoor unit (factory set).
 - COOL/HEAT selection (MASTER) Used to select COOL or HEAT by outdoor unit group with the master unit.
 - COOL/HEAT selection (SLAVE) Used to select COOL or HEAT by outdoor unit group with the slave unit.
2. Check items The following items can be checked.
 - (1) Current operating conditions (Normal / Abnormal / In check operation)
 - (2) Setting conditions of COOL/HEAT selection (Individual / Batch master / Batch slave)
 - (3) Low noise operating conditions (In normal operation / In low noise operation)
 - (4) Demand operating conditions (In normal operation / In demand operation)

Procedure for changing COOL/HEAT selection setting

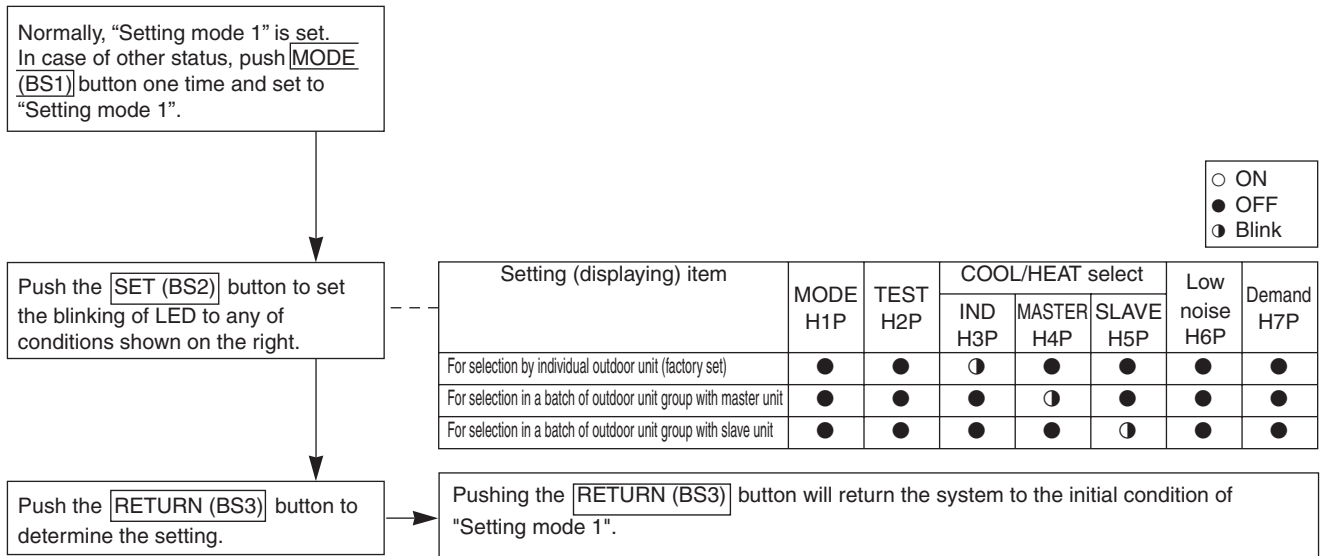

Procedure for checking check items

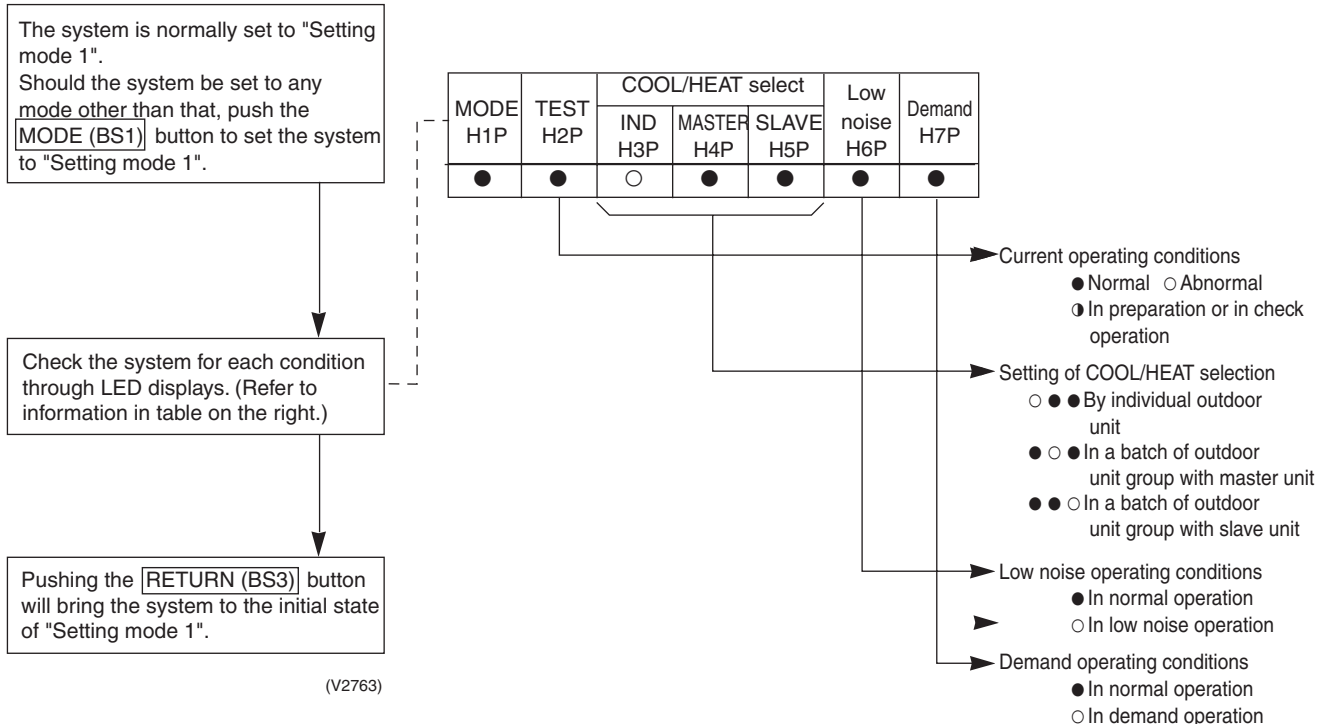

(V2763)

b. “Setting mode 2”

Push and hold the **MODE (BS1)** button for 5 seconds and set to “Setting mode 2”.

<Selection of setting items>

Push the **SET (BS2)** button and set the LED display to a setting item shown in the table on the right.
 ↓
 Push the **RETURN (BS3)** button and decide the item. (The present setting condition is blinked.)

<Selection of setting conditions>

Push the **SET (BS2)** button and set to the setting condition you want.
 ↓
 Push the **RETURN (BS3)** button and decide the condition.

Push the **RETURN (BS3)** button and set to the initial status of “Setting mode 2”

* If you become unsure of how to proceed, push the **MODE (BS1)** button and return to setting mode 1.

(V2764)

No.	Setting item	Description
0	Digital pressure gauge kit display	Used to make setting of contents to display on the digital pressure gauges (e.g. pressure sensors and temperature sensors)
1	Cool/heat unified address	Sets address for cool/heat unified operation.
2	Low noise/demand address	Address for low noise/demand operation
3	Test operation settings	Used to conduct test operation without making changes to the PCB and replacing the refrigerant, after the completion of maintenance.
5	Indoor unit forced fan H	Allows forced operation of indoor unit fan while unit is stopped. (H tap)
6	Indoor unit forced operation	Allows forced operation of indoor unit.
8	Te setting	Target evaporation temperature for cooling
9	Tc setting	Target condensation temperature for heating
10	Defrost changeover setting	Changes the temperature condition for defrost and sets to quick defrost or slow defrost.
11	Sequential operation setting	Sets sequential operation (Factory set to ON)
12	External low noise setting / Demand setting	Reception of external low noise or demand signal
13	AIRNET address	Set address for AIRNET.
16	Setting of hot water	Make this setting to conduct heating operation with hot water heater.
18	High static pressure setting	Make this setting in the case of operating in high static pressure mode with diffuser duct mounted. (In order to mount the diffuser duct, remove the cover from the outdoor unit fan.)
19	Emergency operation (STD compressor operation prohibited)	Used to operate system only with inverter compressor when STD compressor malfunctions. This is a temporary operation extremely impairing comfortable environment. Therefore, prompt replacement of the compressor is required. (This operation, however, is not set with RXYQ5, 8P.)
20	Additional refrigerant charge operation setting	Carries out additional refrigerant charge operation.
21	Refrigerant recovery/vacuumping mode setting	Sets to refrigerant recovery or vacuumping mode.
22	Night-time low noise setting	Sets automatic nighttime low noise operation in a simple way. The operating time is based on “Starting set” and “Ending set”.
24	ENECUT test operation	Used to forcedly turn ON the ENECUT. (Be noted that the ENECUT is only functional with outdoor unit in the stopped state - Japanese domestic model only.)
25	Setting of external low noise level	Sets low noise level when the low noise signal is input from outside.
26	Night-time low noise operation start setting	Sets starting time of nighttime low noise operation. (Night-time low noise setting is also required.)
27	Night-time low noise operation end setting	Sets ending time of nighttime low noise operation. (Night-time low noise setting is also required.)
28	Power transistor check mode *Check after disconnection of compressor wires	Used for trouble diagnosis of DC compressor. Since the waveform of inverter is output without wiring to the compressor, it is convenient to probe whether the trouble comes from the compressor or PC board.
29	Capacity precedence setting	If the capacity control is required, the low noise control is automatically released by this setting during carrying out low noise operation and nighttime low noise operation.

No.	Setting item	Description
30	Demand setting 1	Changes target value of power consumption when demand control 1 is input.
32	Normal demand setting	Normally enables demand control 1 without external input. (Effective to prevent a problem that circuit breaker of small capacity is shut down due to large load.)
35	Setting of difference in elevation for the outdoor unit	Make the setting when the outdoor unit is installed 40 m or more below the indoor unit.
38	Emergency operation (Setting for the master unit operation prohibition in multi-outdoor-unit system)	Used to temporarily prohibit the applicable outdoor unit from operating should there be any faulty part in multi-outdoor-unit system. Since the comfortable environment is extremely impaired, prompt replacement of the part is required.
39	Emergency operation (Setting for the slave unit 1 operation prohibition in multi-outdoor-unit system)	
40	Emergency operation (Setting for the slave unit 2 operation prohibition in multi-outdoor-unit system)	
42	Emergency operation (prohibition of INV compressor operation)	If the INV compressor has a failure, used to run the system only with STD compressor(s). This is a temporary running of the system until the compressor is replaced, thus making comfort extremely worse. Therefore, it is recommended to replace the compressor as soon as possible. (Be noted this setting is not available on model RXYQ5, 8PY1.)

No.	Setting item display							Setting condition display	
	Setting item	MODE H1P	TEST H2P	C/H selection			Low noise H6P		
				IND H3P	Master H4P	Slave H5P			
0	Digital pressure gauge kit display	<input type="radio"/>	<input checked="" type="radio"/>	<input checked="" type="radio"/>	<input checked="" type="radio"/>	<input checked="" type="radio"/>	<input checked="" type="radio"/>	<input checked="" type="radio"/>	Address 0 <input type="radio"/> <input checked="" type="radio"/> <input checked="" type="radio"/> <input checked="" type="radio"/> <input checked="" type="radio"/> <input checked="" type="radio"/> <input checked="" type="radio"/> <input checked="" type="radio"/> Binary number (4 digits) 1 <input type="radio"/> <input checked="" type="radio"/> <input checked="" type="radio"/> <input checked="" type="radio"/> <input checked="" type="radio"/> <input checked="" type="radio"/> <input checked="" type="radio"/> <input checked="" type="radio"/> ~ 15 <input type="radio"/> <input checked="" type="radio"/> <input checked="" type="radio"/> <input type="radio"/> <input type="radio"/> <input type="radio"/> <input type="radio"/> <input type="radio"/>
1	Cool / Heat Unified address	<input type="radio"/>	<input checked="" type="radio"/>	<input checked="" type="radio"/>	<input checked="" type="radio"/>	<input checked="" type="radio"/>	<input checked="" type="radio"/>	<input type="radio"/>	Address 0 <input type="radio"/> <input checked="" type="radio"/> <input checked="" type="radio"/> <input checked="" type="radio"/> <input checked="" type="radio"/> <input checked="" type="radio"/> <input checked="" type="radio"/> <input checked="" type="radio"/> * Binary number (6 digits) 1 <input type="radio"/> <input checked="" type="radio"/> <input checked="" type="radio"/> <input checked="" type="radio"/> <input checked="" type="radio"/> <input checked="" type="radio"/> <input checked="" type="radio"/> <input checked="" type="radio"/> ~ 31 <input type="radio"/> <input checked="" type="radio"/> <input type="radio"/> <input type="radio"/> <input type="radio"/> <input type="radio"/> <input type="radio"/> <input type="radio"/>
2	Low noise/demand address	<input type="radio"/>	<input checked="" type="radio"/>	<input checked="" type="radio"/>	<input checked="" type="radio"/>	<input checked="" type="radio"/>	<input type="radio"/>	<input checked="" type="radio"/>	Address 0 <input type="radio"/> <input checked="" type="radio"/> <input checked="" type="radio"/> <input checked="" type="radio"/> <input checked="" type="radio"/> <input checked="" type="radio"/> <input checked="" type="radio"/> <input checked="" type="radio"/> * Binary number (6 digits) 1 <input type="radio"/> <input checked="" type="radio"/> <input checked="" type="radio"/> <input checked="" type="radio"/> <input checked="" type="radio"/> <input checked="" type="radio"/> <input checked="" type="radio"/> <input checked="" type="radio"/> ~ 31 <input type="radio"/> <input checked="" type="radio"/> <input type="radio"/> <input type="radio"/> <input type="radio"/> <input type="radio"/> <input type="radio"/> <input type="radio"/>
3	Test operation	<input type="radio"/>	<input checked="" type="radio"/>	<input checked="" type="radio"/>	<input checked="" type="radio"/>	<input checked="" type="radio"/>	<input type="radio"/>	<input type="radio"/>	Test operation: ON <input type="radio"/> <input checked="" type="radio"/> <input checked="" type="radio"/> <input checked="" type="radio"/> <input checked="" type="radio"/> <input checked="" type="radio"/> <input checked="" type="radio"/> <input checked="" type="radio"/> Test operation: OFF <input type="radio"/> <input checked="" type="radio"/> <input checked="" type="radio"/> <input checked="" type="radio"/> <input checked="" type="radio"/> <input checked="" type="radio"/> <input checked="" type="radio"/> <input checked="" type="radio"/> *
5	Indoor forced fan H	<input type="radio"/>	<input checked="" type="radio"/>	<input checked="" type="radio"/>	<input checked="" type="radio"/>	<input type="radio"/>	<input checked="" type="radio"/>	<input type="radio"/>	Normal operation <input type="radio"/> <input checked="" type="radio"/> <input checked="" type="radio"/> <input checked="" type="radio"/> <input checked="" type="radio"/> <input checked="" type="radio"/> <input checked="" type="radio"/> <input checked="" type="radio"/> * Indoor forced fan H <input type="radio"/> <input checked="" type="radio"/> <input checked="" type="radio"/> <input checked="" type="radio"/> <input checked="" type="radio"/> <input checked="" type="radio"/> <input checked="" type="radio"/> <input checked="" type="radio"/>
6	Indoor forced operation	<input type="radio"/>	<input checked="" type="radio"/>	<input checked="" type="radio"/>	<input checked="" type="radio"/>	<input type="radio"/>	<input type="radio"/>	<input checked="" type="radio"/>	Normal operation <input type="radio"/> <input checked="" type="radio"/> <input checked="" type="radio"/> <input checked="" type="radio"/> <input checked="" type="radio"/> <input checked="" type="radio"/> <input checked="" type="radio"/> <input checked="" type="radio"/> * Indoor forced operation <input type="radio"/> <input checked="" type="radio"/> <input checked="" type="radio"/> <input checked="" type="radio"/> <input checked="" type="radio"/> <input checked="" type="radio"/> <input checked="" type="radio"/> <input checked="" type="radio"/>
8	Te setting	<input type="radio"/>	<input checked="" type="radio"/>	<input checked="" type="radio"/>	<input type="radio"/>	<input checked="" type="radio"/>	<input checked="" type="radio"/>	<input checked="" type="radio"/>	High <input type="radio"/> <input checked="" type="radio"/> <input checked="" type="radio"/> <input checked="" type="radio"/> <input type="radio"/> <input checked="" type="radio"/> <input checked="" type="radio"/> <input checked="" type="radio"/> Normal (factory setting) <input type="radio"/> <input checked="" type="radio"/> <input checked="" type="radio"/> <input checked="" type="radio"/> <input checked="" type="radio"/> <input checked="" type="radio"/> <input checked="" type="radio"/> <input checked="" type="radio"/> * Low <input type="radio"/> <input checked="" type="radio"/> <input checked="" type="radio"/> <input checked="" type="radio"/> <input checked="" type="radio"/> <input checked="" type="radio"/> <input checked="" type="radio"/> <input checked="" type="radio"/>
9	Tc setting	<input type="radio"/>	<input checked="" type="radio"/>	<input checked="" type="radio"/>	<input type="radio"/>	<input checked="" type="radio"/>	<input checked="" type="radio"/>	<input type="radio"/>	High <input type="radio"/> <input checked="" type="radio"/> <input checked="" type="radio"/> <input checked="" type="radio"/> <input type="radio"/> <input checked="" type="radio"/> <input checked="" type="radio"/> <input checked="" type="radio"/> Normal (factory setting) <input type="radio"/> <input checked="" type="radio"/> <input checked="" type="radio"/> <input checked="" type="radio"/> <input checked="" type="radio"/> <input checked="" type="radio"/> <input checked="" type="radio"/> <input checked="" type="radio"/> * Low <input type="radio"/> <input checked="" type="radio"/> <input checked="" type="radio"/> <input checked="" type="radio"/> <input checked="" type="radio"/> <input checked="" type="radio"/> <input checked="" type="radio"/> <input checked="" type="radio"/>
10	Defrost changeover setting	<input type="radio"/>	<input checked="" type="radio"/>	<input checked="" type="radio"/>	<input type="radio"/>	<input checked="" type="radio"/>	<input type="radio"/>	<input checked="" type="radio"/>	Quick defrost <input type="radio"/> <input checked="" type="radio"/> <input checked="" type="radio"/> <input checked="" type="radio"/> <input type="radio"/> <input checked="" type="radio"/> <input checked="" type="radio"/> <input checked="" type="radio"/> Normal (factory setting) <input type="radio"/> <input checked="" type="radio"/> <input checked="" type="radio"/> <input checked="" type="radio"/> <input checked="" type="radio"/> <input checked="" type="radio"/> <input checked="" type="radio"/> <input checked="" type="radio"/> * Slow defrost <input type="radio"/> <input checked="" type="radio"/> <input checked="" type="radio"/> <input checked="" type="radio"/> <input checked="" type="radio"/> <input checked="" type="radio"/> <input checked="" type="radio"/> <input checked="" type="radio"/>
11	Sequential operation setting	<input type="radio"/>	<input checked="" type="radio"/>	<input checked="" type="radio"/>	<input type="radio"/>	<input checked="" type="radio"/>	<input type="radio"/>	<input type="radio"/>	OFF <input type="radio"/> <input checked="" type="radio"/> <input checked="" type="radio"/> <input checked="" type="radio"/> <input checked="" type="radio"/> <input checked="" type="radio"/> <input checked="" type="radio"/> <input checked="" type="radio"/> ON <input type="radio"/> <input checked="" type="radio"/> <input checked="" type="radio"/> <input checked="" type="radio"/> <input checked="" type="radio"/> <input checked="" type="radio"/> <input checked="" type="radio"/> <input checked="" type="radio"/> *
12	External low noise/demand setting	<input type="radio"/>	<input checked="" type="radio"/>	<input checked="" type="radio"/>	<input type="radio"/>	<input type="radio"/>	<input checked="" type="radio"/>	<input checked="" type="radio"/>	External low noise/demand: NO <input type="radio"/> <input checked="" type="radio"/> <input checked="" type="radio"/> <input checked="" type="radio"/> <input checked="" type="radio"/> <input checked="" type="radio"/> <input checked="" type="radio"/> <input checked="" type="radio"/> * External low noise/demand: YES <input type="radio"/> <input checked="" type="radio"/> <input checked="" type="radio"/> <input checked="" type="radio"/> <input checked="" type="radio"/> <input checked="" type="radio"/> <input checked="" type="radio"/> <input checked="" type="radio"/>
13	Airnet address	<input type="radio"/>	<input checked="" type="radio"/>	<input checked="" type="radio"/>	<input type="radio"/>	<input type="radio"/>	<input checked="" type="radio"/>	<input type="radio"/>	Address 0 <input type="radio"/> <input checked="" type="radio"/> <input checked="" type="radio"/> <input checked="" type="radio"/> <input checked="" type="radio"/> <input checked="" type="radio"/> <input checked="" type="radio"/> <input checked="" type="radio"/> * Binary number (6 digits) 1 <input type="radio"/> <input checked="" type="radio"/> <input checked="" type="radio"/> <input checked="" type="radio"/> <input checked="" type="radio"/> <input checked="" type="radio"/> <input checked="" type="radio"/> <input checked="" type="radio"/> ~ 63 <input type="radio"/> <input type="radio"/> <input type="radio"/> <input type="radio"/> <input type="radio"/> <input type="radio"/> <input type="radio"/> <input type="radio"/>
16	Setting of hot water heater	<input type="radio"/>	<input checked="" type="radio"/>	<input type="radio"/>	<input checked="" type="radio"/>	<input checked="" type="radio"/>	<input checked="" type="radio"/>	<input checked="" type="radio"/>	OFF <input type="radio"/> <input checked="" type="radio"/> <input checked="" type="radio"/> <input checked="" type="radio"/> <input checked="" type="radio"/> <input checked="" type="radio"/> <input checked="" type="radio"/> <input checked="" type="radio"/> * ON <input type="radio"/> <input checked="" type="radio"/> <input checked="" type="radio"/> <input checked="" type="radio"/> <input checked="" type="radio"/> <input checked="" type="radio"/> <input checked="" type="radio"/> <input checked="" type="radio"/>
18	High static pressure setting	<input type="radio"/>	<input checked="" type="radio"/>	<input type="radio"/>	<input checked="" type="radio"/>	<input checked="" type="radio"/>	<input type="radio"/>	<input checked="" type="radio"/>	High static pressure setting: OFF <input type="radio"/> <input checked="" type="radio"/> <input checked="" type="radio"/> <input checked="" type="radio"/> <input checked="" type="radio"/> <input checked="" type="radio"/> <input checked="" type="radio"/> <input checked="" type="radio"/> * High static pressure setting: ON <input type="radio"/> <input checked="" type="radio"/> <input checked="" type="radio"/> <input checked="" type="radio"/> <input checked="" type="radio"/> <input checked="" type="radio"/> <input checked="" type="radio"/> <input checked="" type="radio"/>
19	Emergency operation (STD compressor is inhibited to operate.)	<input type="radio"/>	<input checked="" type="radio"/>	<input type="radio"/>	<input checked="" type="radio"/>	<input checked="" type="radio"/>	<input type="radio"/>	<input type="radio"/>	OFF <input type="radio"/> <input checked="" type="radio"/> <input checked="" type="radio"/> <input checked="" type="radio"/> <input checked="" type="radio"/> <input checked="" type="radio"/> <input checked="" type="radio"/> <input checked="" type="radio"/> * STD 1, 2 operation: Inhibited <input type="radio"/> <input checked="" type="radio"/> <input checked="" type="radio"/> <input checked="" type="radio"/> <input checked="" type="radio"/> <input checked="" type="radio"/> <input checked="" type="radio"/> <input checked="" type="radio"/> STD 2 operation: Inhibited <input type="radio"/> <input checked="" type="radio"/> <input checked="" type="radio"/> <input checked="" type="radio"/> <input checked="" type="radio"/> <input checked="" type="radio"/> <input checked="" type="radio"/> <input checked="" type="radio"/>
20	Additional refrigerant charging operation setting	<input type="radio"/>	<input checked="" type="radio"/>	<input type="radio"/>	<input checked="" type="radio"/>	<input type="radio"/>	<input checked="" type="radio"/>	<input checked="" type="radio"/>	Refrigerant charging: OFF <input type="radio"/> <input checked="" type="radio"/> <input checked="" type="radio"/> <input checked="" type="radio"/> <input checked="" type="radio"/> <input checked="" type="radio"/> <input checked="" type="radio"/> <input checked="" type="radio"/> * Refrigerant charging: ON <input type="radio"/> <input checked="" type="radio"/> <input checked="" type="radio"/> <input checked="" type="radio"/> <input checked="" type="radio"/> <input checked="" type="radio"/> <input checked="" type="radio"/> <input checked="" type="radio"/>
21	Refrigerant recovery/vacuumping mode setting	<input type="radio"/>	<input checked="" type="radio"/>	<input type="radio"/>	<input checked="" type="radio"/>	<input type="radio"/>	<input checked="" type="radio"/>	<input type="radio"/>	Refrigerant recovery / vacuumping: OFF <input type="radio"/> <input checked="" type="radio"/> <input checked="" type="radio"/> <input checked="" type="radio"/> <input checked="" type="radio"/> <input checked="" type="radio"/> <input checked="" type="radio"/> <input checked="" type="radio"/> * Refrigerant recovery / vacuumping: ON <input type="radio"/> <input checked="" type="radio"/> <input checked="" type="radio"/> <input checked="" type="radio"/> <input checked="" type="radio"/> <input checked="" type="radio"/> <input checked="" type="radio"/> <input checked="" type="radio"/>

No.	Setting item display								Setting condition display
	Setting item	MODE H1P	TEST H2P	C/H selection			Low noise H6P	Demand H7P	
				IND H3P	Master H4P	Slave H5P			
									* Factory set
22	Night-time low noise setting	<input type="radio"/>	<input checked="" type="radio"/>	<input type="radio"/>	<input checked="" type="radio"/>	<input type="radio"/>	<input type="radio"/>	<input checked="" type="radio"/>	OFF <input type="radio"/> ● ● ● ● ● ● ● ● * Level 1 (outdoor fan with 6 step or <input type="radio"/> ● ● ● ● ● ● ● ● Level 2 (outdoor fan with 5 step or <input type="radio"/> ● ● ● ● ● ● ● ● Level 3 (outdoor fan with 4 step or <input type="radio"/> ● ● ● ● ● ● ● ●
24	ENECUT test operation (Domestic Japan only)	<input type="radio"/>	<input checked="" type="radio"/>	<input type="radio"/>	<input type="radio"/>	<input checked="" type="radio"/>	<input checked="" type="radio"/>	<input checked="" type="radio"/>	ENECUT output OFF <input type="radio"/> ● ● ● ● ● ● ● ● * ENECUT output forced ON <input type="radio"/> ● ● ● ● ● ● ● ●
25	Low noise setting	<input type="radio"/>	<input checked="" type="radio"/>	<input type="radio"/>	<input type="radio"/>	<input checked="" type="radio"/>	<input checked="" type="radio"/>	<input type="radio"/>	Level 1 (outdoor fan with 6 step or lower) <input type="radio"/> ● ● ● ● ● ● ● ● Level 2 (outdoor fan with 5 step or lower) <input type="radio"/> ● ● ● ● ● ● ● ● * Level 3 (outdoor fan with 4 step or lower) <input type="radio"/> ● ● ● ● ● ● ● ●
26	Night-time low noise operation start setting	<input type="radio"/>	<input checked="" type="radio"/>	<input type="radio"/>	<input type="radio"/>	<input checked="" type="radio"/>	<input type="radio"/>	<input checked="" type="radio"/>	About 20:00 <input type="radio"/> ● ● ● ● ● ● ● ● About 22:00 (factory setting) <input type="radio"/> ● ● ● ● ● ● ● ● * About 24:00 <input type="radio"/> ● ● ● ● ● ● ● ●
27	Night-time low noise operation end setting	<input type="radio"/>	<input checked="" type="radio"/>	<input type="radio"/>	<input type="radio"/>	<input checked="" type="radio"/>	<input type="radio"/>	<input type="radio"/>	About 6:00 <input type="radio"/> ● ● ● ● ● ● ● ● About 7:00 <input type="radio"/> ● ● ● ● ● ● ● ● About 8:00 (factory setting) <input type="radio"/> ● ● ● ● ● ● ● ● *
28	Power transistor check mode	<input type="radio"/>	<input checked="" type="radio"/>	<input type="radio"/>	<input type="radio"/>	<input type="radio"/>	<input checked="" type="radio"/>	<input checked="" type="radio"/>	OFF <input type="radio"/> ● ● ● ● ● ● ● ● * ON <input type="radio"/> ● ● ● ● ● ● ● ●
29	Capacity precedence setting	<input type="radio"/>	<input checked="" type="radio"/>	<input type="radio"/>	<input type="radio"/>	<input type="radio"/>	<input checked="" type="radio"/>	<input type="radio"/>	OFF <input type="radio"/> ● ● ● ● ● ● ● ● * ON <input type="radio"/> ● ● ● ● ● ● ● ●
30	Demand setting 1	<input type="radio"/>	<input checked="" type="radio"/>	<input type="radio"/>	<input type="radio"/>	<input type="radio"/>	<input type="radio"/>	<input checked="" type="radio"/>	60 % demand <input type="radio"/> ● ● ● ● ● ● ● ● 70 % demand <input type="radio"/> ● ● ● ● ● ● ● ● * 80 % demand <input type="radio"/> ● ● ● ● ● ● ● ●
32	Normal demand setting	<input type="radio"/>	<input type="radio"/>	<input checked="" type="radio"/>	<input checked="" type="radio"/>	<input checked="" type="radio"/>	<input checked="" type="radio"/>	<input checked="" type="radio"/>	OFF <input type="radio"/> ● ● ● ● ● ● ● ● * ON <input type="radio"/> ● ● ● ● ● ● ● ●
35	Setting of difference in elevation for the outdoor unit	<input type="radio"/>	<input type="radio"/>	<input checked="" type="radio"/>	<input checked="" type="radio"/>	<input checked="" type="radio"/>	<input type="radio"/>	<input type="radio"/>	Normal <input type="radio"/> ● ● ● ● ● ● ● ● 65 m or less <input type="radio"/> ● ● ● ● ● ● ● ● 90 m or less <input type="radio"/> ● ● ● ● ● ● ● ●
38	Emergency operation (Master unit with multi-outdoor-unit system is inhibited to operate.)	<input type="radio"/>	<input type="radio"/>	<input checked="" type="radio"/>	<input checked="" type="radio"/>	<input type="radio"/>	<input type="radio"/>	<input checked="" type="radio"/>	OFF <input type="radio"/> ● ● ● ● ● ● ● ● * Master unit operation: Inhibited <input type="radio"/> ● ● ● ● ● ● ● ●
39	Emergency operation (Slave unit 1 with multi-outdoor-unit system is inhibited to operate.)	<input type="radio"/>	<input type="radio"/>	<input checked="" type="radio"/>	<input checked="" type="radio"/>	<input type="radio"/>	<input type="radio"/>	<input type="radio"/>	OFF <input type="radio"/> ● ● ● ● ● ● ● ● * Slave unit 1 operation: Inhibited <input type="radio"/> ● ● ● ● ● ● ● ●
40	Emergency operation (Slave unit 2 with multi-outdoor-unit system is inhibited to operate.)	<input type="radio"/>	<input type="radio"/>	<input checked="" type="radio"/>	<input type="radio"/>	<input checked="" type="radio"/>	<input checked="" type="radio"/>	<input checked="" type="radio"/>	OFF <input type="radio"/> ● ● ● ● ● ● ● ● * Slave unit 2 operation: Inhibited <input type="radio"/> ● ● ● ● ● ● ● ●
42	Emergency operation (prohibition of INV compressor operation)	<input type="radio"/>	<input type="radio"/>	<input checked="" type="radio"/>	<input type="radio"/>	<input checked="" type="radio"/>	<input type="radio"/>	<input checked="" type="radio"/>	Normal operation <input type="radio"/> ● ● ● ● ● ● ● ● * Emergency operation (prohibition of INV compressor operation) <input type="radio"/> ● ● ● ● ● ● ● ●

c. Monitor mode

To enter the monitor mode, push the **MODE (BS1)** button when in "Setting mode 1".

<Selection of setting item>

Push the **SET (BS2)** button and set the LED display to a setting item.

<Confirmation on setting contents>

Push the **RETURN (BS3)** button to display different data of set items.

Push the **RETURN (BS3)** button and switches to the initial status of "Monitor mode".

* Push the **MODE (BS1)** button and returns to "Setting mode 1".

(V2765)

No.	Setting item	LED display							Data display
		H1P	H2P	H3P	H4P	H5P	H6P	H7P	
0	Various settings	●	●	●	○	●	●	●	Lower 4 digits
1	C/H unified address	●	●	●	●	●	●	○	Lower 6 digits
2	Low noise/demand address	●	●	●	●	●	○	●	
3	Not used	●	●	●	●	●	○	○	
4	Airnet address	●	●	●	●	○	●	●	
5	Number of connected indoor units	●	●	●	●	○	●	○	
6	Number of connected BS units	●	●	●	●	○	○	●	
7	Number of connected zone units (excluding outdoor and BS unit)	●	●	●	●	○	○	○	
8	Number of outdoor units	●	●	●	○	●	●	●	
9	Number of connected BS units	●	●	●	○	●	●	○	Lower 4 digits: upper
10	Number of connected BS units	●	●	●	○	●	○	●	Lower 4 digits: lower
11	Number of zone units (excluding outdoor and BS unit)	●	●	●	○	●	○	○	Lower 6 digits
12	Number of terminal blocks	●	●	●	○	○	●	●	Lower 4 digits: upper
13	Number of terminal blocks	●	●	●	○	○	●	○	Lower 4 digits: lower
14	Contents of malfunction (the latest)	●	●	●	○	○	○	●	Malfunction code table
15	Contents of malfunction (1 cycle before)	●	●	●	○	○	○	○	
16	Contents of malfunction (2 cycle before)	●	●	○	●	●	●	●	
20	Contents of retry (the latest)	●	●	○	●	○	●	●	
21	Contents of retry (1 cycle before)	●	●	○	●	○	●	○	
22	Contents of retry (2 cycle before)	●	●	○	●	○	○	●	
25	Number of multi connection outdoor units	●	●	○	○	●	●	○	Lower 6 digits

The numbers in the "No." column represent the number of times to press the SET (BS2) button.

Setting item 0 Display contents of "Number of units for various settings"

EMG operation / backup operation setting	ON	●	●	●	○	●	●	●
	OFF	●	●	●	●	●	●	●
Defrost select setting	Short	●	●	●	●	○	●	●
	Medium	●	●	●	●	●	●	●
	Long	●	●	●	●	●	●	●
Te setting	H	●	●	●	●	○	●	●
	M	●	●	●	●	●	○	●
	L	●	●	●	●	●	●	●
Tc setting	H	●	●	●	●	●	○	●
	M	●	●	●	●	●	●	○
	L	●	●	●	●	●	●	●

Push the SET button and match with the LEDs No. 1 - 15, push the RETURN button, and confirm the data for each setting.

★ Data such as addresses and number of units is expressed as binary numbers; the two ways of expressing are as follows:

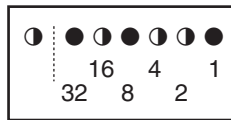

The No. 1 cool/heat unified address is expressed as a binary number consisting of the lower 6 digits. (0 - 63)

In ① the address is 010110 (binary number), which translates to $16 + 4 + 2 = 22$ (base 10 number). In other words, the address is 22.

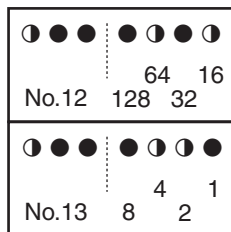

The number of terminal blocks for No. 12 and 13 is expressed as an 8-digit binary number, which is the combination of four upper, and four lower digits for No. 12 and 13 respectively. (0 - 128)

In ② the address for No. 12 is 0101, the address for No. 13 is 0110, and the combination of the two is 01010110 (binary number), which translates to $64 + 16 + 4 + 2 = 86$ (base 10 number). In other words, the number of terminal block is 86.

★ See the preceding page for a list of data, etc. for No. 0 - 22.

4.4.2.2 Cool / Heat Mode Switching (*Heat Pump model only)

There are the following 4 cool/heat switching modes.

- ① Set cool/heat separately for each outdoor unit system by indoor unit remote control.
- ② Set cool/heat separately for each outdoor unit system by cool/heat switching remote control.
- ③ Set cool/heat for more than one outdoor unit system simultaneously in accordance with unified master outdoor unit by indoor unit remote control.
- ④ Set cool/heat for more than one outdoor unit system simultaneously in accordance with unified master outdoor unit by cool/heat switching remote control.

① Set Cool / Heat Separately for Each Outdoor Unit System by Indoor Unit Remote Control

- ◆ It does not matter whether or not there is outdoor - outdoor unit wiring.
- ◆ Set outdoor unit PC board DS1-1 to IN (factory set).
- ◆ Set cool/heat switching to IND (individual) for "Setting mode 1" (factory set).
- ◆ Set the master unit (= indoor unit having the right to select the cooling/heating operation mode).

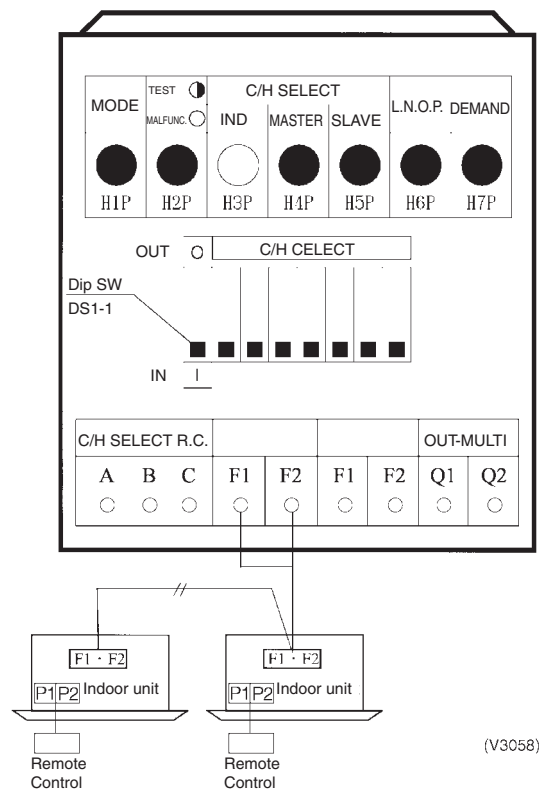

<Set the master unit (= indoor unit having the right to select the cooling/heating operation mode).>

In the case of wired remote controls

- After the check operation, "CHANGEOVER UNDER CONTROL" is flashing in all connected remote controls.
- Select an indoor unit to be used as the master unit in accordance with the request from the customer. (It is recommended to select an indoor unit which will be used most often as the master unit.)
- Press the operation mode selector button in the remote control of the indoor unit selected as the master unit.
- In that remote control, "CHANGEOVER UNDER CONTROL" disappears. That remote control will control changeover of the cooling/heating operation mode.
- In other remote controls, "CHANGEOVER UNDER CONTROL" lights.

For the details, refer to the installation manual supplied together with the indoor unit.

In the case of infrared remote controls

- After the check operation, the timer lamp is flashing in all connected indoor units.
- Select an indoor unit to be used as the master unit in accordance with the request from the customer. (It is recommended to select an indoor unit which will be used most often as the master unit.)
- Press the operation selector mode button in the remote control of the indoor unit selected as the master unit. A "peep" sound is emitted, and the timer lamp turns off in all indoor units.
- That indoor unit will control changeover of the cooling/heating operation mode.

② Set Cool / Heat Separately for Each Outdoor Unit System by Cool / Heat Switching remote control

- ◆ It does not matter whether or not there is outdoor - outdoor unit wiring.
- ◆ Set outdoor unit PC board DS1-1 to OUT (factory set).
- ◆ Set cool/heat switching to IND (individual) for “Setting mode 1” (factory set).

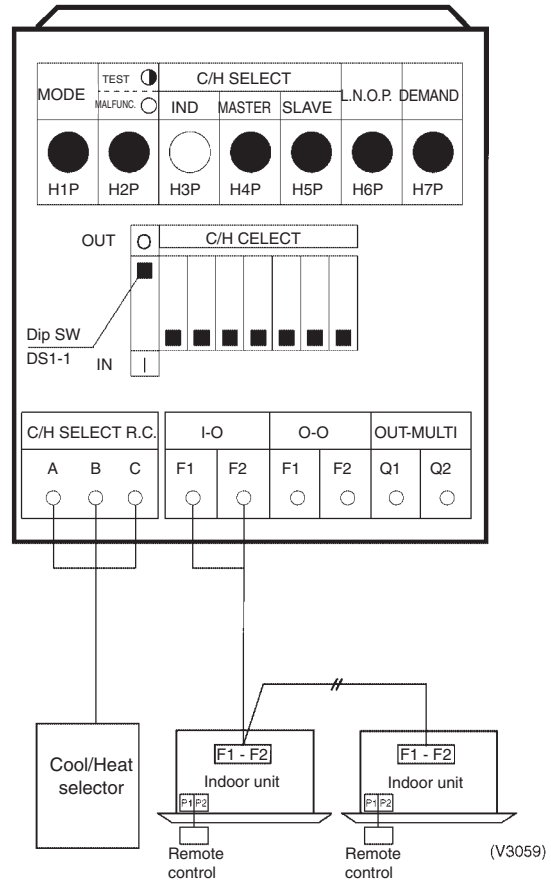

③ Set Cool / Heat for More Than One Outdoor Unit System Simultaneously in Accordance with Unified Master Outdoor Unit by Indoor Unit Remote Control

- ◆ Install the external control adapter for outdoor unit on either the outdoor-outdoor, indoor-outdoor transmission line.
- ◆ Set outdoor unit PC board DS1-1 to IN (factory set).
- ◆ In setting mode 1, set the outdoor unit you want to give cool/heat selection permission to as the group master, and set the other outdoor units as group slave units.
- ◆ Set the outdoor unit external control adapter SS1 to BOTH (factory set) or C/H, and SS2 to OFF (factory set).

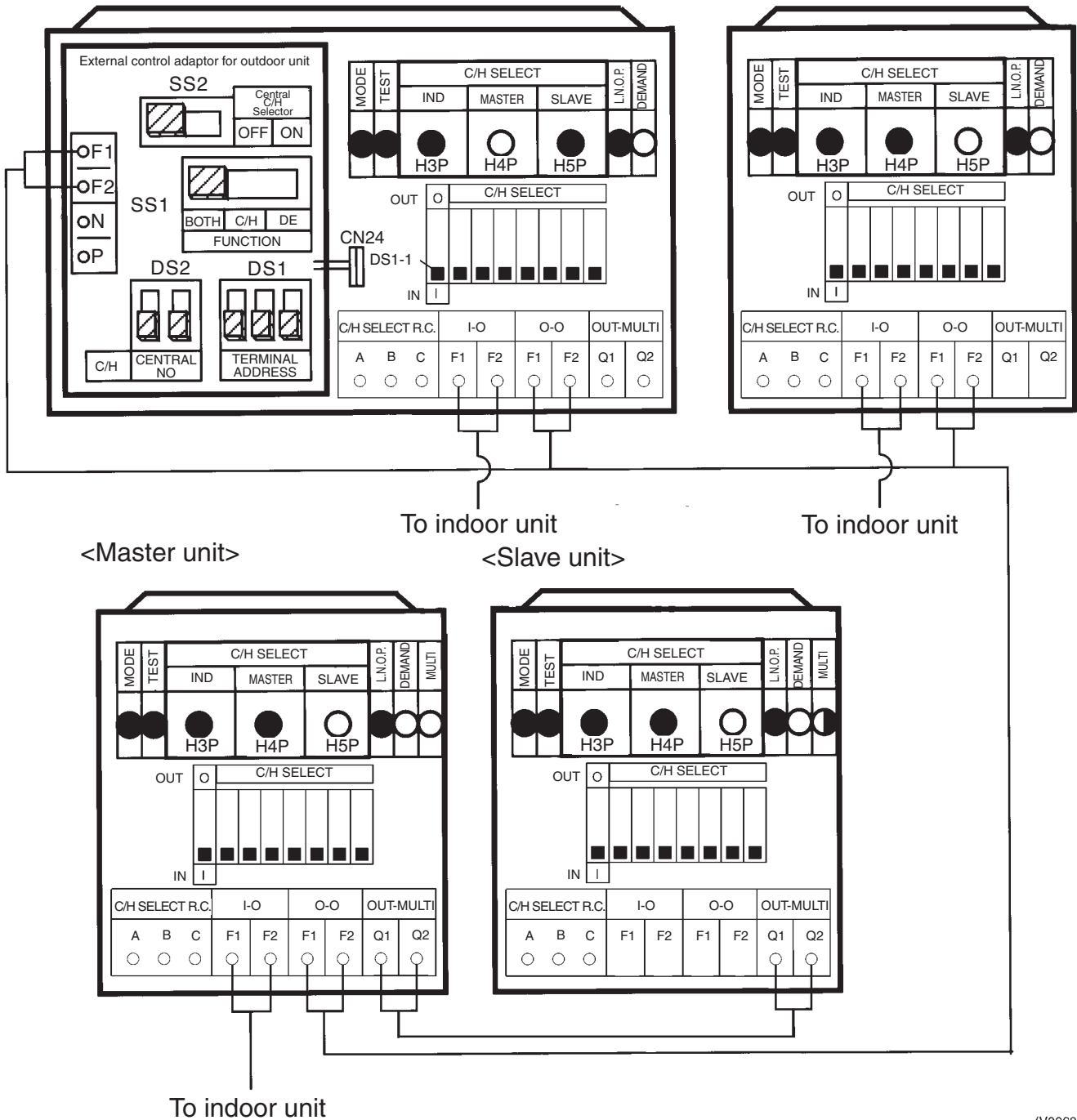

(V3060)

Multi outdoor units connection

④ Set Cool / Heat for More Than One Outdoor Unit System Simultaneously in Accordance with Unified Master Outdoor Unit by Cool / Heat Switching Remote Control

- ◆ Install the external control adapter for outdoor unit on either the outdoor-outdoor, indoor-outdoor transmission line.
- ◆ Mount the COOL/HEAT selection remote control to the master outdoor unit for the unified control.
- ◆ Set the DS1-1 on the PC board of master outdoor unit to OUT.
- ◆ In setting mode 1, set the outdoor unit you want to give cool/heat selection permission to as the group master, and set the other outdoor units as group slave units.
- ◆ Set the outdoor unit external control adapter SS1 to BOTH (factory set) or C/H, and SS2 to OFF (factory set).

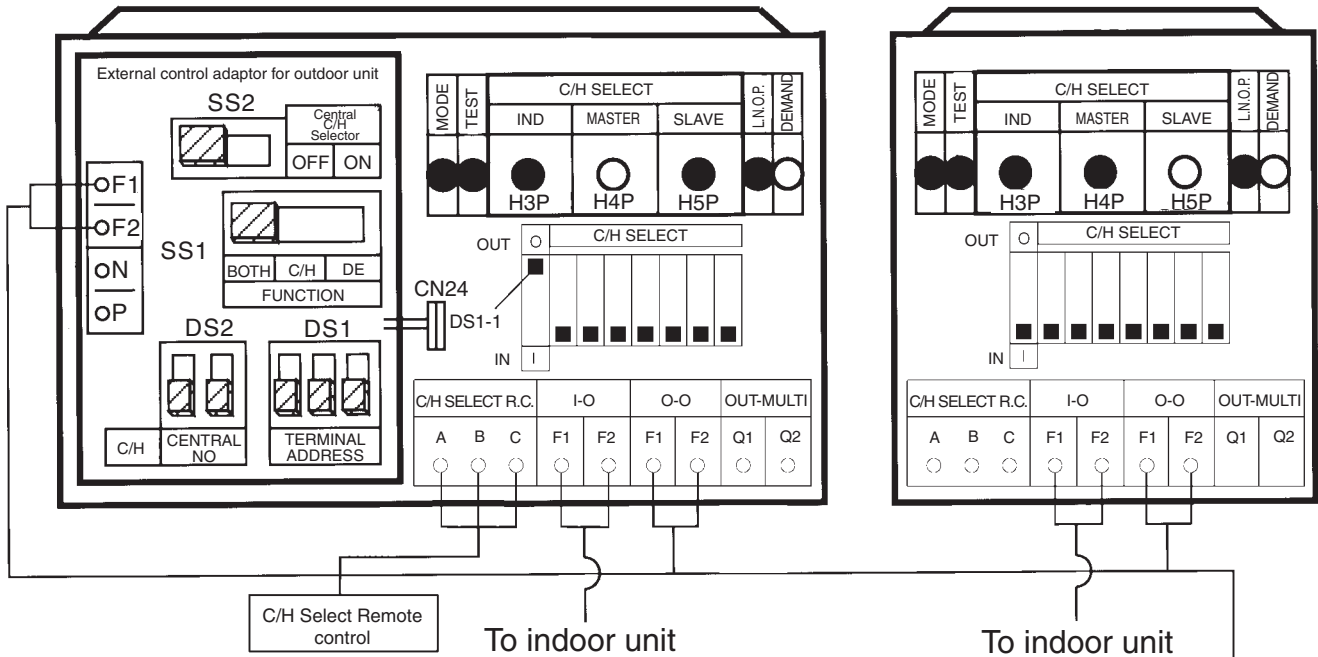

<Master unit>

<Slave unit>

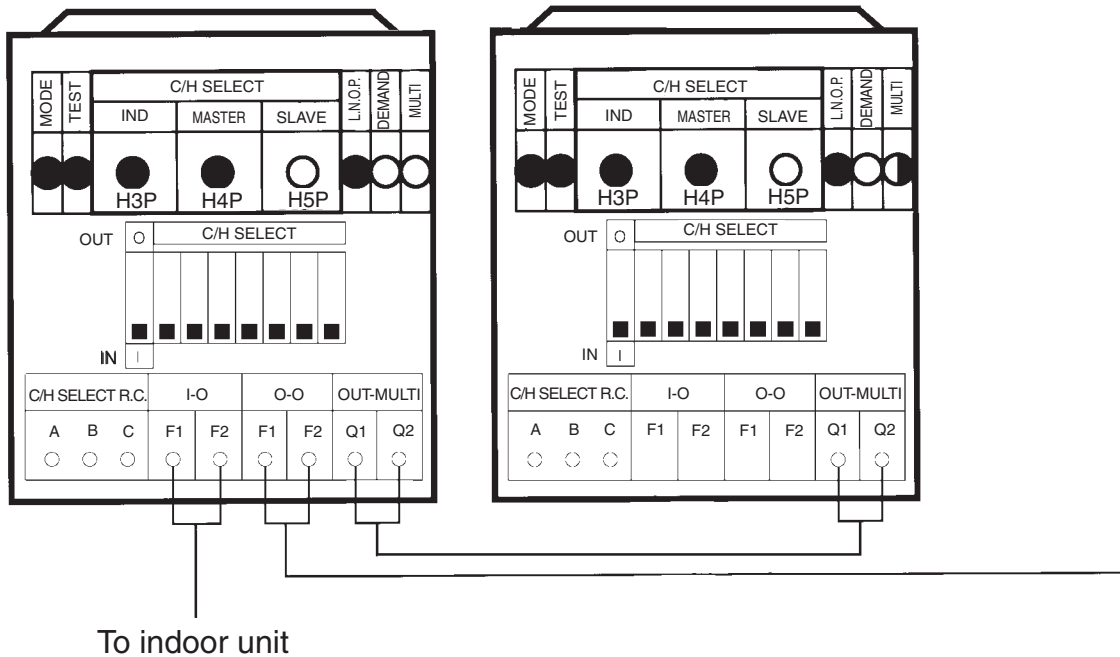

To indoor unit

Multi outdoor units connection

(V3060-1)

Supplementation on ③ and ④.

When switching cool/heat for each adapter PC board with the use of more than one adapter PC board, set the address of the external control adapter for outdoor unit PC board DS1 and DS2 so that it matches the unified cool/heat address of outdoor unit main PC board.

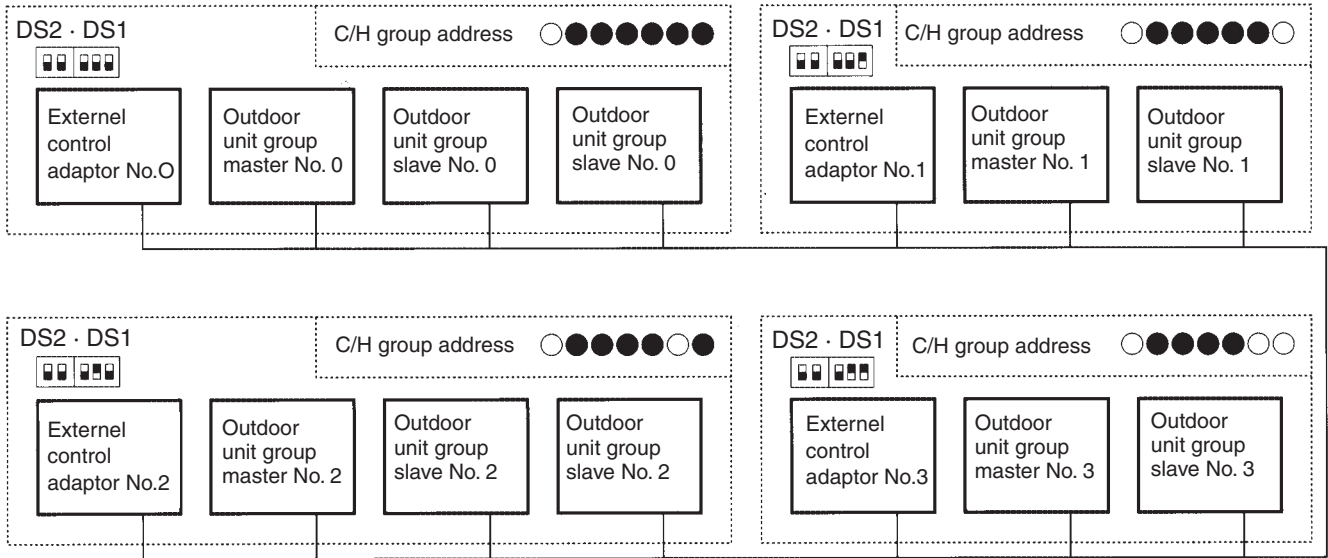

(V2723)

Address setting for ③ and ④ (Set lower 5 digits with binary number.) [No.0 to No.31]

Address No.	Outdoor unit PC board LED Set with setting mode 2		External control adaptor for outdoor unit	
	DS2	DS1	DS2	DS1
No 0	○ ●	● ● ● ● ● 0		
No 1	○ ●	● ● ● ● ○ 1		
No 2	○ ●	● ● ● ○ ● 2		
No 3	○ ●	● ● ● ○ ○ 3		
No 4	○ ●	● ● ○ ● ● 4		
}	}	}	}	}
No 30	○ ●	○ ○ ○ ○ ● 30		
No 31	○ ●	○ ○ ○ ○ ○ 31		

○ ON ● OFF Upper position (ON) lower position (OFF)
(The shaded part shows knob)

(V2724)

4.4.2.3 Setting of Low Noise Operation and Demand Operation

Setting of Low Noise Operation

By connecting the external contact input to the low noise input of the outdoor unit external control adapter (optional), you can lower operating noise by 2-3 dB.

Setting	Content
Mode 1	Set the outdoor unit fan to Step 6 or lower.
Mode 2	Set the outdoor unit fan to Step 5 or lower.
Mode 3	Set the outdoor unit fan to Step 4 or lower.

A. When the low noise operation is carried out by external instructions (with the use of the external control adapter for outdoor unit)

1. While in "Setting mode 2", set the setting condition for set item No. 12 (Setting of external low noise/demand operation) to "YES".
2. If necessary, while in "Setting mode 2", select the setting condition (i.e., "Mode 1", "Mode 2", or "Mode 3") for set item No. 25 (Setting of external low noise level).
3. If necessary, while in "Setting mode 2", set the setting condition for the set item No. 29 (Setting of capacity precedence) to "ON".
(If the condition is set to "ON", when the air-conditioning load reaches a high level, the low noise operation command will be ignored to put the system into normal operation mode.)

B. When the low noise operation is carried out automatically at night (The external control adapter for outdoor unit is not required)

1. While in "Setting mode 2", select the setting condition (i.e., "Mode 1", "Mode 2", or "Mode 3") for set item No. 22 (Setting of nighttime low noise level).
2. If necessary, while in "Setting mode 2", select the setting condition (i.e., "20:00", "22:00", or "24:00") for set item No. 26 (Setting of start time of nighttime low noise operation).
(Use the start time as a guide since it is estimated according to outdoor temperatures.)
3. If necessary, while in "Setting mode 2", select the setting condition (i.e., "06:00", "07:00", or "08:00") for set item No. 27 (Setting of end time of nighttime low noise operation).
(Use the end time as a guide since it is estimated according to outdoor temperatures.)
4. If necessary, while in "Setting mode 2", set the setting condition for set item No. 29 (Setting of capacity precedence) to "ON".
(If the condition is set to "ON", when the air-conditioning load reaches a high level, the system will be put into normal operation mode even during nighttime.)

Image of operation in the case of A

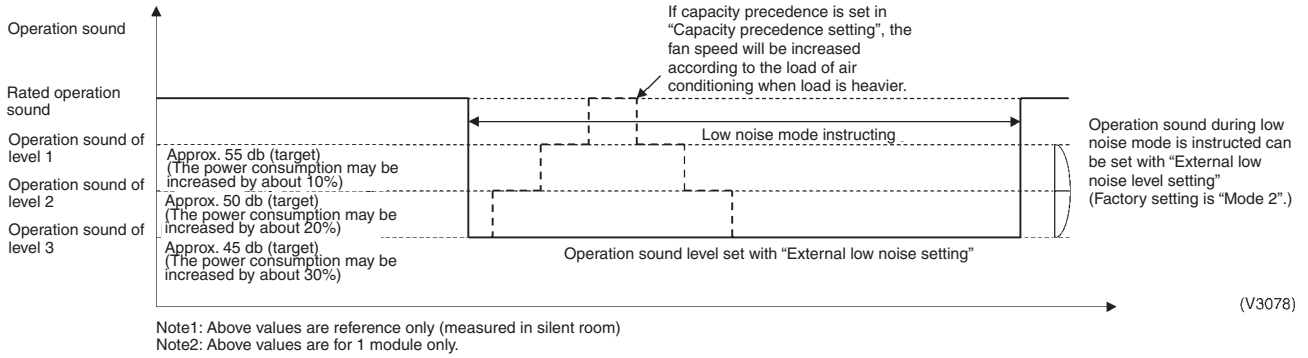

Image of operation in the case of B

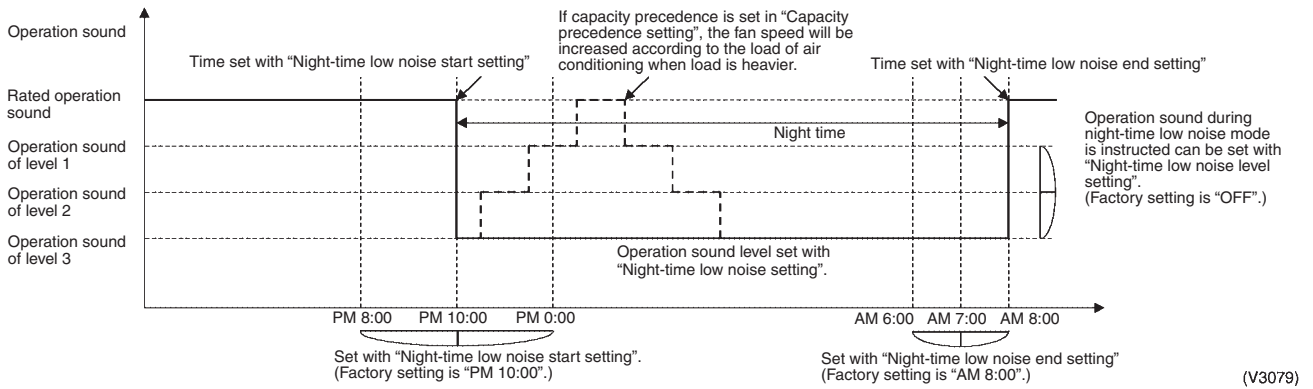
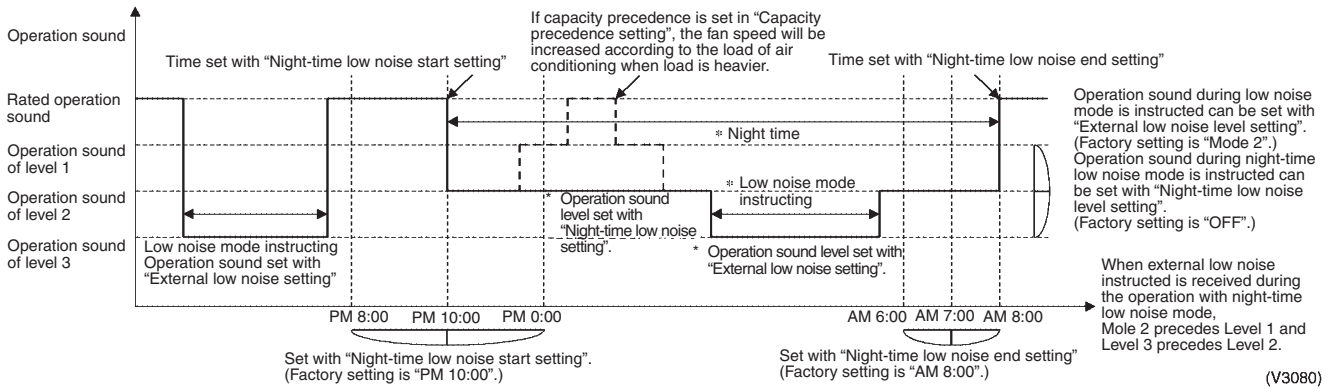

Image of operation in the case of A and B



Setting of Demand Operation

By connecting the external contact input to the demand input of the outdoor unit external control adapter (optional), the power consumption of unit operation can be saved suppressing the compressor operating condition.

Set item	Condition	Content
Demand 1	Mode 1	The compressor operates at approx. 60% or less of rating.
	Mode 2	The compressor operates at approx. 70% or less of rating.
	Mode 3	The compressor operates at approx. 80% or less of rating.
Demand 2	—	The compressor operates at approx. 40% or less of rating.

A. When the demand operation is carried out by external instructions (with the use of the external control adapter for outdoor unit).

1. While in "Setting mode 2", set the setting condition for set item No. 12 (Setting of external low noise/demand operation) to "YES".
2. If necessary, while in "Setting mode 2", select the set item No. 30 (Setting of Demand 1 level) and then set the setting condition to targeted mode.

B. When the Normal demand operation is carried out. (Use of the external control adapter for outdoor unit is not required.)

1. While in "Setting mode 2", make setting of the set item No. 32 (Setting of constant demand) to "ON".
2. While in "Setting mode 2", select the set item No. 30 (Setting of Demand 1 level) and then set the setting condition to targeted mode.

Image of operation in the case of A

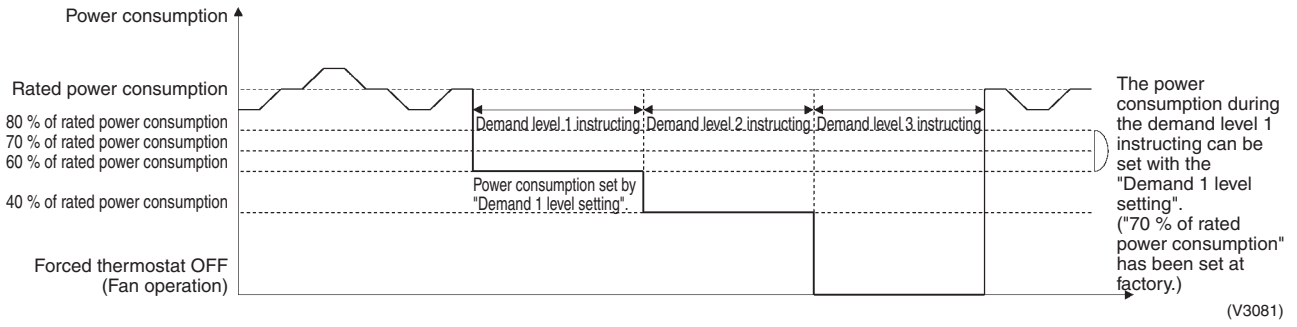

Image of operation in the case of B

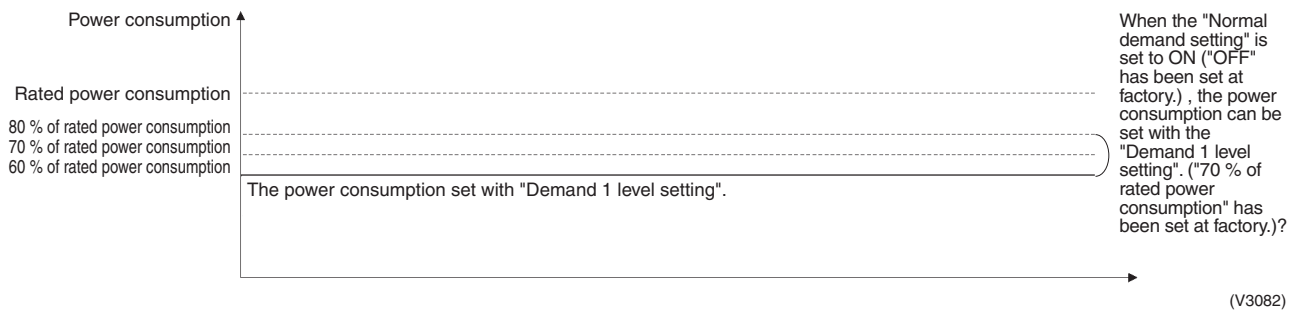
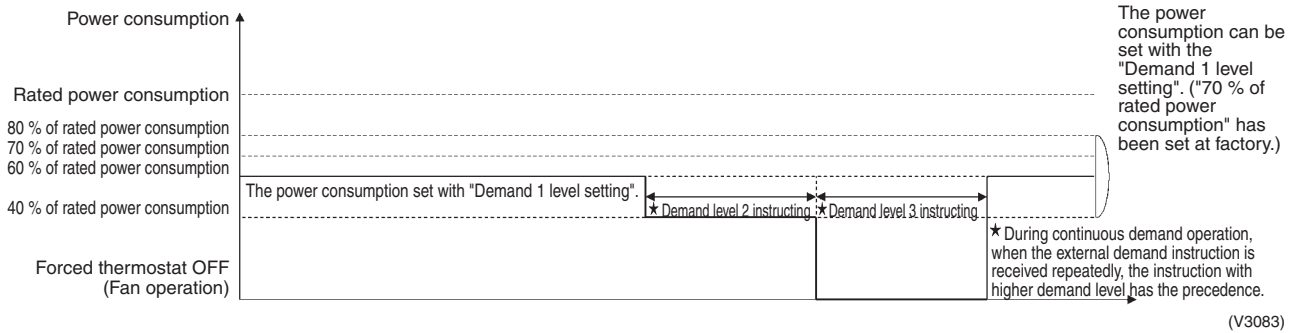

Image of operation in the case of A and B



**Detailed Setting
Procedure of Low
Noise Operation
and Demand
Control****1. Setting mode 1 (H1P off)**

- ① In setting mode 2, push the BS1 (MODE button) one time. → Setting mode 1 is entered and H1P off.
During the setting mode 1 is displayed, "In low noise operation" and "In demand control" are displayed.

2. Setting mode 2 (H1P on)

- ① In setting 1, push and hold the BS1 (MODE button) for more than 5 seconds. → Setting mode 2 is entered and H1P lights.
- ② Push the BS2 (SET button) several times and match the LED display with the Setting No. you want.
- ③ Push the BS3 (RETURN button) one time, and the present setting content is displayed.
→ Push the BS2 (SET button) several times and match the LED display with the setting content (as shown below) you want.
- ④ Push the BS3 (RETURN button) two times. → Returns to ①.
- ⑤ Push the BS1 (MODE button) one time. → Returns to the setting mode 1 and turns H1P off.

○: ON ●: OFF ◐: Blink

Setting No.	Setting contents	① Setting No. indication							② Setting No. indication							Setting contents	③ Setting contents indication (Initial setting)																				
		H1P	H2P	H3P	H4P	H5P	H6P	H7P	H1P	H2P	H3P	H4P	H5P	H6P	H7P		H1P	H2P	H3P	H4P	H5P	H6P	H7P														
12	External low noise / Demand setting	○	●	●	●	●	●	●	○	●	●	○	○	●	●	NO (Factory set)	○	●	●	●	●	●	●	◐													
									○	●	●	○	○	●	●	YES	○	●	●	●	●	●	◐	●													
22	Night-time low noise setting	○	●	○	●	○	○	●	○	●	○	●	○	○	●	OFF (Factory setting)	○	●	●	●	●	●	●	●													
									○	●	○	○	○	○	●	Mode 1	○	●	●	●	●	●	●	◐													
									○	●	○	○	○	○	●	Mode 2	○	●	●	●	●	●	◐	●													
									○	●	○	○	○	○	●	Mode 3	○	●	●	●	●	●	◐	◐													
25	External low noise setting	○	●	○	○	●	●	○	○	●	○	○	●	●	○	Mode 1	○	●	●	●	●	●	●	◐													
									○	●	○	○	●	●	○	Mode 2 (Factory setting)	○	●	●	●	●	●	◐	●													
									○	●	○	○	●	●	○	Mode 3	○	●	●	●	●	◐	●	●													
26	Night-time low noise start setting	○	●	○	○	●	○	●	○	●	○	○	●	○	●	PM 8:00	○	●	●	●	●	●	●	◐													
									○	●	○	○	●	○	●	PM 10:00 (Factory setting)	○	●	●	●	●	●	◐	●													
									○	●	○	○	●	○	●	PM 0:00	○	●	●	●	●	◐	●	●													
27	Night-time low noise end setting	○	●	○	○	●	○	○	○	●	○	○	●	○	○	AM 6:00	○	●	●	●	●	●	●	◐													
									○	●	○	○	●	○	○	AM 7:00	○	●	●	●	●	●	◐	●													
									○	●	○	○	●	○	○	AM 8:00 (Factory setting)	○	●	●	●	●	◐	●	●													
29	Capacity precedence setting	○	●	○	○	○	○	●	○	○	●	○	○	○	●	○	Low noise precedence (Factory setting)	○	●	●	●	●	●	●	◐												
										○	●	○	○	○	○	●	○	Capacity precedence	○	●	●	●	●	●	◐	●											
30	Demand setting 1	○	●	○	○	○	○	○	○	○	○	○	●	○	●	○	○	○	○	○	●	60 % of rated power consumption	○	●	●	●	●	●	●	◐							
														○	●	○	○	○	○	○	○	○	○	○	○	●	70 % of rated power consumption (Factory setting)	○	●	●	●	●	●	◐	●		
														○	●	○	○	○	○	○	○	○	○	○	○	●	80 % of rated power consumption	○	●	●	●	●	◐	●	●		
32	Normal demand setting	○	●	○	○	○	○	○	○	○	○	○	○	○	○	●	○	○	○	○	○	○	○	○	○	○	○	○	OFF (Factory setting)	○	●	●	●	●	●	●	◐
															○	●	○	○	○	○	○	○	○	○	○	○	○	○	ON	○	●	●	●	●	●	◐	●

Setting mode indication section

Setting No. indication section

Set contents indication section

4.4.2.4 Setting of Refrigerant Recovery Mode

When carrying out the refrigerant collection on site, fully open the respective expansion valve of indoor and outdoor units.

All indoor and outdoor unit's operation are prohibited.

[Operation procedure]

- ① In **setting mode 2** with units in stop mode, set "Refrigerant Recovery / Vacuuming mode" to ON. The respective expansion valve of indoor and outdoor units are fully opened. (H2P turns to display "TEST OPERATION" (blinks), "TEST OPERATION" and "UNDER CENTRALIZED CONTROL" are displayed on the remote control, and the all indoor / outdoor unit operation is prohibited.
After setting, do not cancel "Setting Mode 2" until completion of refrigerant recovery operation.
 - ② Collect the refrigerant using a refrigerant recovery unit. (See the instruction attached to the refrigerant recovery unit for more detail.)
 - ③ Press Mode button "BS1" once and reset "Setting Mode 2".
-

4.4.2.5 Setting of Vacuuming Mode

In order to perform vacuuming operation at site, fully open the expansion valves of indoor and outdoor units and turn on some solenoid valves.

[Operating procedure]

- ① With **Setting Mode 2** while the unit stops, set "Refrigerant recovery / Vacuuming mode" to ON. The expansion valves of indoor and outdoor units fully open and some of solenoid valves open.
(H2P blinks to indicate the test operation, and the remote control displays "Test Operation" and "Under centralized control", thus prohibiting operation.)
After setting, do not cancel "Setting Mode 2" until completion of Vacuuming operation.
- ② Use the vacuum pump to perform vacuuming operation.
- ③ Press Mode button "BS1" once and reset "Setting Mode 2".

4.4.2.6 Check Operation Detail.

CHECK OPERATION FUNCTION

(Press the MODE button BS1 once and set to SETTING MODE 1 (H1P: OFF))

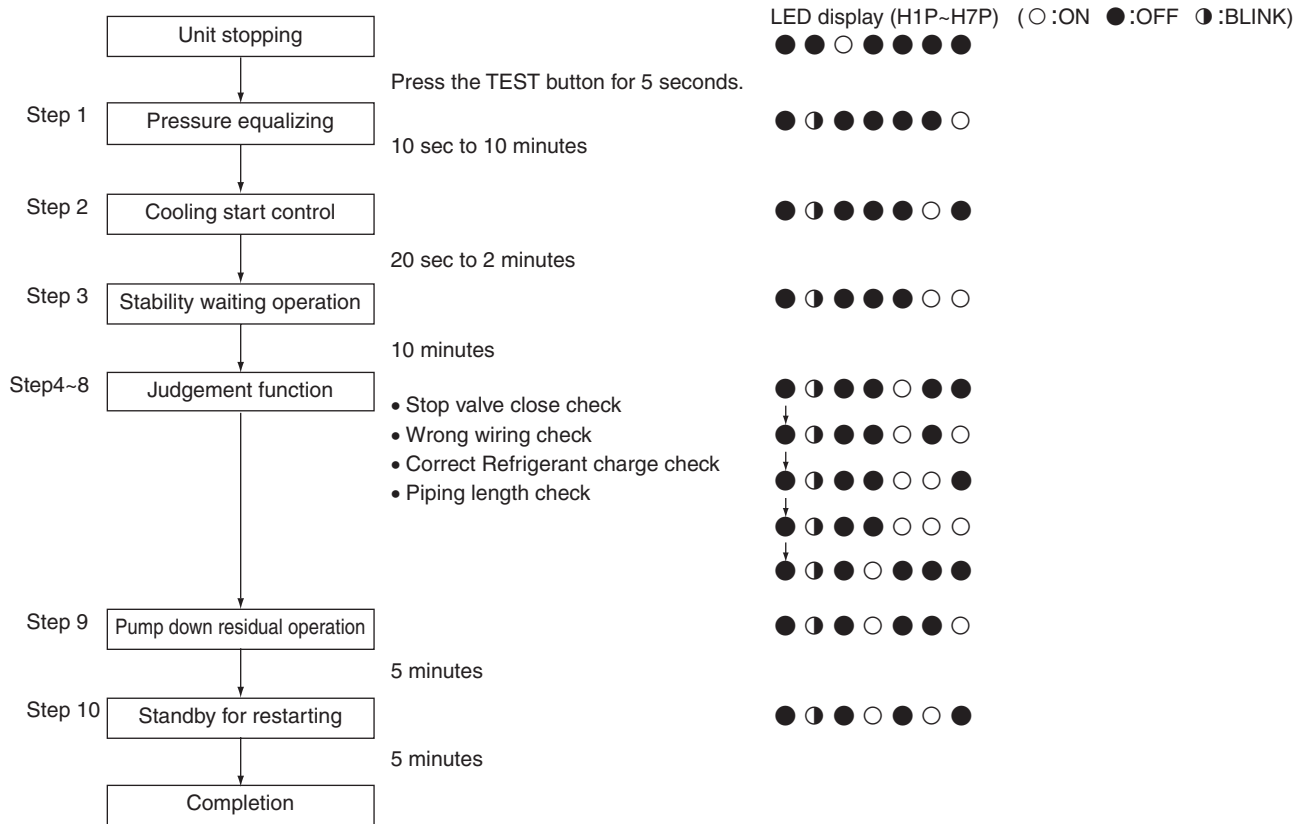

5. Caution for Refrigerant Leaks

5.1 Caution for Refrigerant Leaks

5.1.1 Introduction

Points to note in connection with refrigerant leaks

The installer and system specialist shall secure safety against leakage according to local regulations or standards. The following standards may be applicable if local regulations are not available.

5.1.2 Maximum Concentration Level

The maximum charge of refrigerant and the calculation of the maximum concentration of refrigerant is directly related to the humanly occupied space in to which it could leak.

The unit of measurement of the concentration is kg/m³ (the weight in kg of the refrigerant gas in 1m³ volume of the occupied space).

Compliance to the local applicable regulations and standards for the maximum allowable concentration level is required.

In Australia the maximum allowed concentration level of refrigerant to a humanly space is limited to 0.35 kg/m³ for R-407C, and 0.44 kg/m³ for R-410A.

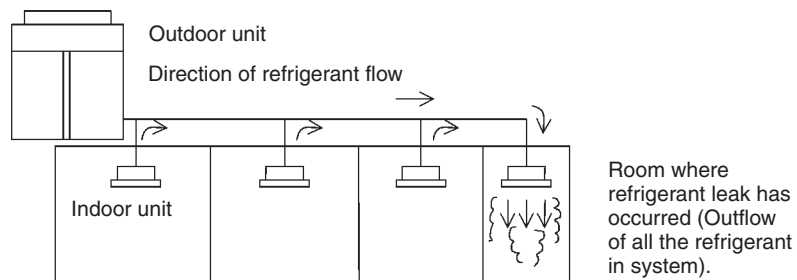

Pay special attention to the place, such as a basement, etc., where refrigerant can stay, since refrigerant is heavier than air.

5.1.3 Procedure for Checking Dangerous Concentration

Check the Dangerous concentration in accordance with steps (1)-(4) below and take whatever action is necessary.

Step1: Calculate the amount of refrigerant (kg) charged to each system separately.

(Amount of refrigerant in a single indoor unit system)	+	(Additional charging amount)	=	Total amount of refrigerant (kg) in the system

Amount of refrigerant with which the system is charged before leaving the factory

Amount of refrigerant added locally in accordance with the length or diameter of the refrigerant piping



Notes: Where a single refrigerant facility is divided into 2 entirely independent refrigerant systems then use the amount of refrigerant with which each separate system is charged.

Step 2:

Calculate the smallest room volume (m³)

In a case like the following calculate the volume of (a), (b) as a single room or as the smallest room.

A. Where there are no smaller room divisions.

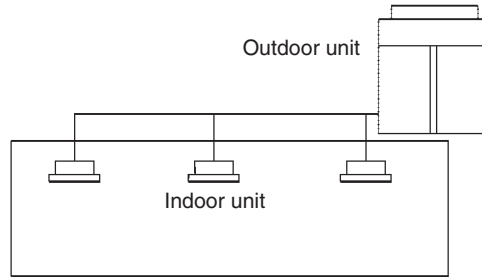

B. Where there is a room division but there is an opening between the rooms sufficiently large to permit a free flow of air back and forth.

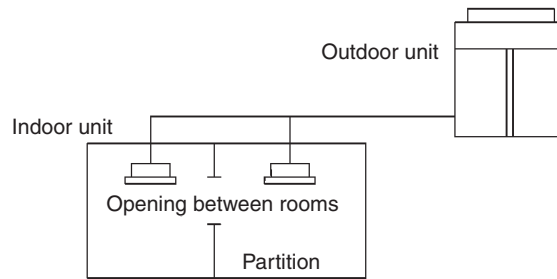

(Where there is an opening without a door or where there are openings above and below the door which are each equivalent in size to 0.15% or more of the floor area.)

C. Where there is a gas leak detection alarm device linked to a mechanical ventilator in the smallest room then the next smallest room will become the measurement target.

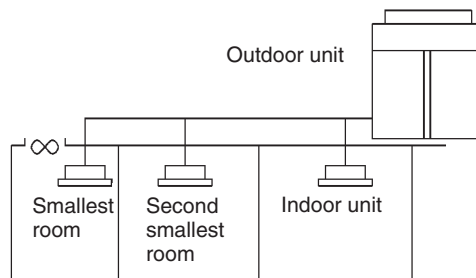

Step 3:

Calculate the refrigerant density using the results of the calculations in Step (1) and (2) above.

Total volume of refrigerant in the refrigerant system

_____ <= Dangerous concentration (kg/m³)

Size (m³) of the smallest room in which there is an indoor unit installed

in the case of: R-407C = 0.35kg/m³, R-410A = 0.44kg/m³

If the result of the above calculation exceeds the dangerous concentration level then make similar calculations for the second then third smallest room and so on until the result falls short of the concentration level.

Step 4:**Dealing with situations where the result exceeds the dangerous concentration level.**

Where the installation of a facility results in a concentration in excess of the dangerous concentration level then it may be necessary to revise the system design to some extent or else take one of the following courses of action.

Action 1: Making openings which will allow the air to flow freely into the room. Make openings above and below the door which are each equivalent in size to 0.15% or more of the floor area or make a doorless opening.

Action 2: Fit a mechanical ventilator linked to a gas leak detection alarm device.

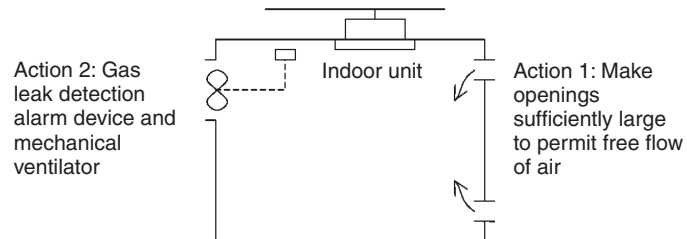
**Notes:**

This precaution shows the requirement of EN.

The precaution should be followed in accordance of local code.

6. Hand Over to Customer

6.1 Operational Steps

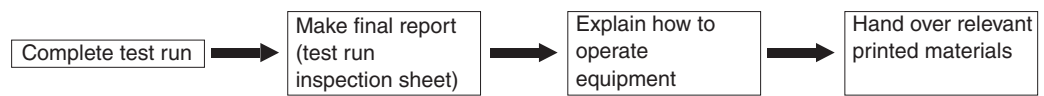

(V1050)

Important Points

- The measurements taken during the test run should be recorded and kept on a test run inspection sheet.
- Do not forget to record the **length of the refrigerant piping** and the **refrigerant additional charging volume** on the plate on the back of the outdoor unit external notice board, as this information will be required for servicing the system.
- Explain to the customer how to operate the equipment and let him try it.
- Assemble all the relevant diagrams and other printed matter which is required to operate the system and hand it all over to the customer (on the spot) and tell him to keep it.

List of equipment which has been delivered

Contract drawings

It is essential to prepare a control wiring diagram which clarifies the refrigerant system and the control system.

1 set of operation manuals

Names of those responsible for the work (emergency contact address)

Equipment guarantees

(V1143)

- Make the service contact address clear.

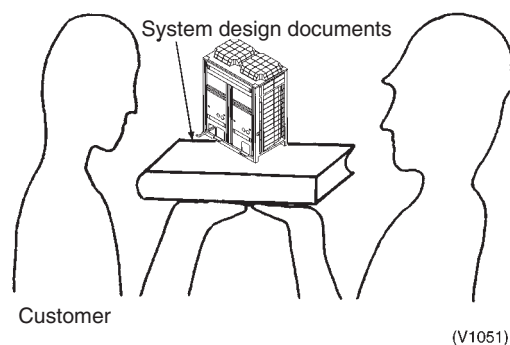

7. Appendix

7.1 Operating Noise of Indoor Units

7.1.1 Difference between Catalogue Data and Actual Noise

Operating noise differs depending on the place of measurement (room) because of the various degrees with which the room reverberates the sound. To determine the amount of reverberation under uniform conditions, the unit has been measured in a dead room with results having been compiled in the below table. The actual sound produced in unit operation can be determined from Table 1.

Sound pressure rise due to room reverberation (Higher than catalogue data)

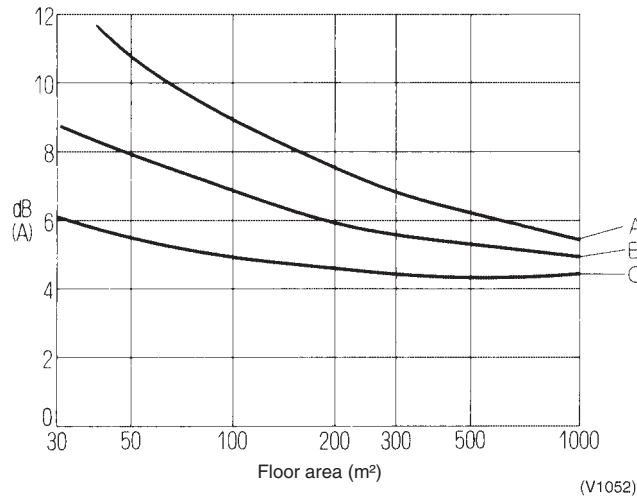

Table 1

		A	B	C
Room Interior Detection	Floor	Mortar	Linoleum tile	Carpet
	Walls	Mortar	Plaster	Fiberglass + Saroncross finish
	Ceiling	Mortar	mineral wool tile	Fiberglass + Saroncross finish
Average Absorbed Sound (Room with Approx. 50 m² Floor Area)		0.05	0.12	0.25
		Typical office		
Estimated value to be added to catalogue value		11~12	8~8.5	5~6

Classifications of indoor unit environments (reference data)

Table 2

Classification	Environment	Example	Faint Noises (NOTE 2)	Recommended Operating Noise on Site
1	Non-active places requiring silence	Reception rooms, libraries, sitting rooms, hospitals (examining rooms) (NOTE 1)	~35	~40
2	Sedate business activities that do not disturb people even over time	Quiet offices, classrooms, small conference rooms, lobbies	~40	~45
3	Somewhat quiet settings that permit soft-spoken conversation, typical activities	Small offices, large conferences rooms, quiet stores, restaurants	~45	~50
4	Somewhat loud settings that permit regular conversation, brisk activity	Large offices, typical stores, cafeterias	~50	~55
5	Loud places that permit conversation in a loud voice, highly active place with many people	Loud large-side offices, large cafeterias, loud stores	~55	~60
6	Rather loud settings	Factories, gymnasiums, recreational places like pachinko parlors	~60	~65



- Notes:**
1. Excluding bedrooms
 2. Reference values of faint noises in the place of usage

7.1.2 Faint Noises and Correcting Operating Noise with Respect to Faint Noises

Faint noises are defined as peripheral sounds existing while the unit is not running, which are picked up when measuring operating noise. If these faint noises are 10 dB or more than the noise produced by the unit, the measured value can be taken as the operating noise of the unit. But, the difference must be corrected if less than 10 dB, because of the effect these noises have on the actual measured value. Also, when the sound meter remains unchanged even while the unit is stopped, we can determine the operational noise to be at least 10 dB less than the faint noises, but we cannot pinpoint the operating noise exactly.

For example, if the faint noises are some 65 dB and the noise produced by the unit in operation is 70 dB, the indicated difference comes to 5 dB. Using Table 3, we recommend you correct the operating noise by about 2 dB to 68 dB.

Table 3 Correcting the effect of faint noises

Unit: dB

Difference between when noise is produced and when not	1	2	3	4	5	6	7	8	9	10
Corrective Value	-6.9	-4.4	-3.0	-2.3	-1.7	-1.25	-0.95	-0.75	-0.60	-0.45

7.1.3 Calculating Operating Noise

When two or more units are running at the same time, the amount of operating noise they produce rises. The total amount of noise produced can be obtained ahead of time with Chart 4.

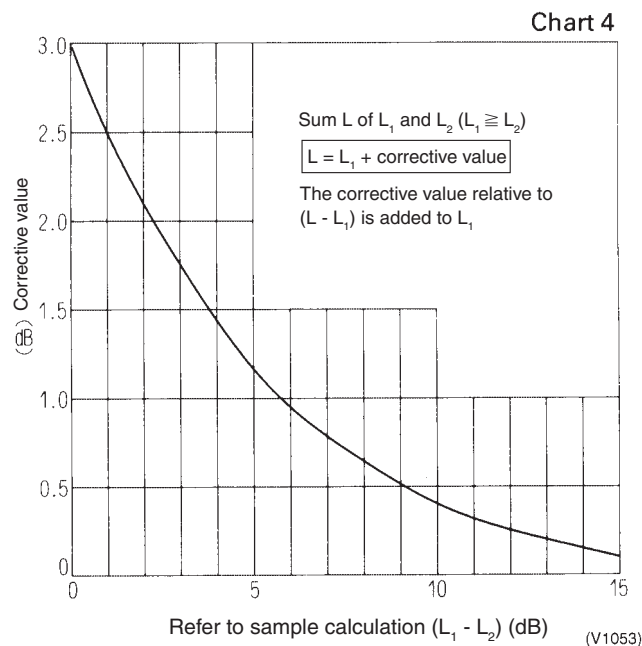

Sample calculation 1

L_1 and L_2 are given as compounded sounds of 50 and 49 dB respectively. Since $L_1 - L_2 = 50 - 49 = 1$, the corrective value is 2.5, therefore $50 + 2.5 = 52.5$ dB.

Sample calculation 2

When sounds of 40 dB, 38 dB, 37 dB and 40 dB are placed in order of magnitude, we obtain the following:

40 dB, 40 dB, 38 dB, 37 dB

To start, the difference between 40 dB and 40 dB is 0, therefore we take a corrective value of 3dB and obtain $40 + 3 = 43$ dB. The compounded sound of 43 dB and 38 dB has a 5.0 dB difference, thus a corrective value of 1.2 dB, which gives us 44.2 dB from $43 + 1.2$. In the same manner, the corrective value for 44.2 dB and 37 dB is approximately 0.7 dB, or in other words, $44.2 + 0.7 = 44.9$ dB.

7.2 Piping Installation Point

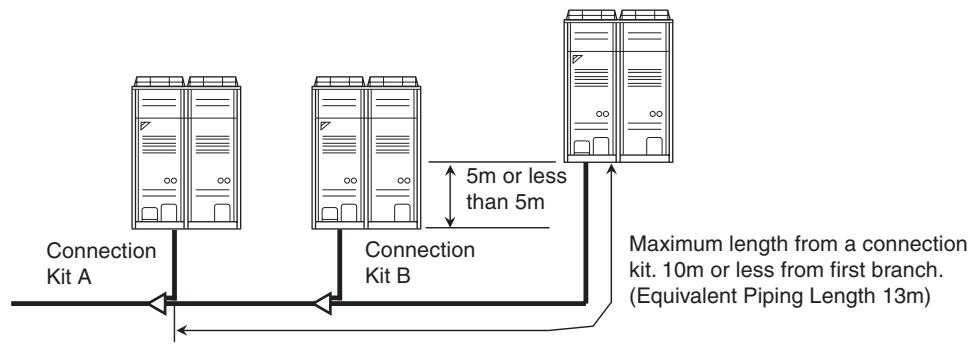

Since there is a possibility that oil may be collected on a stop machine side, install piping between outdoor units to go to level or go up to an outdoor unit, and to make a slope.

(V3036)

The projection part between multi connection piping kits

When the piping length between the multi connection kits or between multi connection kit and outdoor unit is 2m or more, prepare a vertical projection part (200mm or more as shown below) only on the gas pipe line location less than 2m from multi connection kit.

In the case of 2m or less

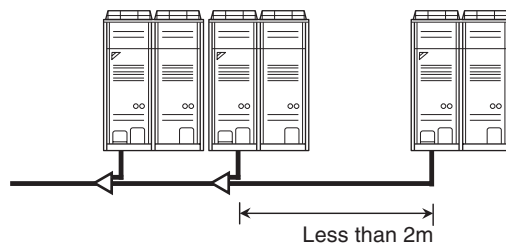

(V3037)

In the case of 2m or more

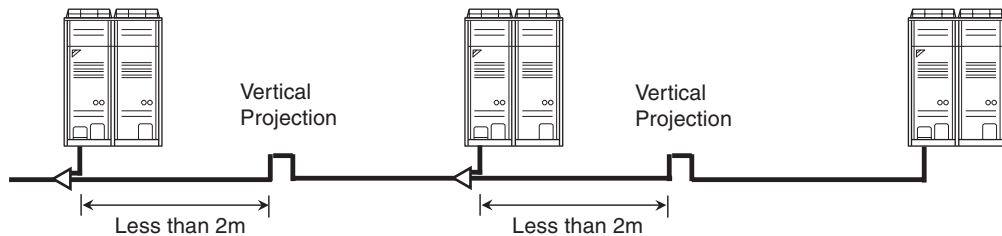
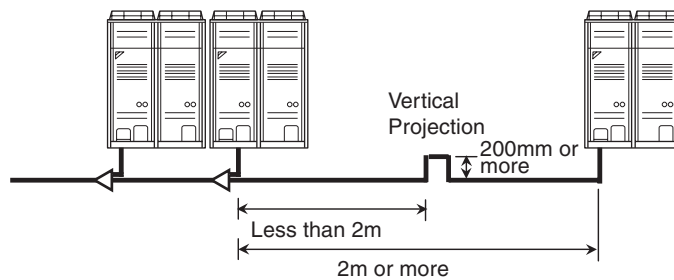

(V3038)

<The Example of A Wrong Pattern>

Wrong



Oil is collected to the outdoor unit at the time of a stop, because of bottom omission of piping.

(V3039)

Wrong

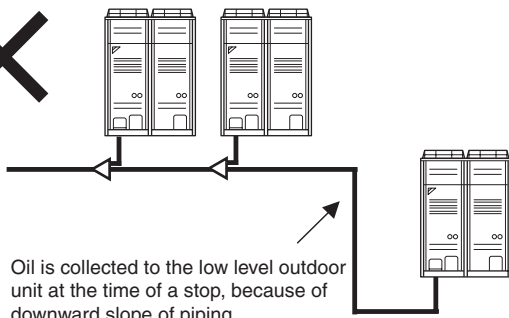

Oil is collected to the low level outdoor unit at the time of a stop, because of downward slope of piping.



The example of installation on which oil is not collected.

Good

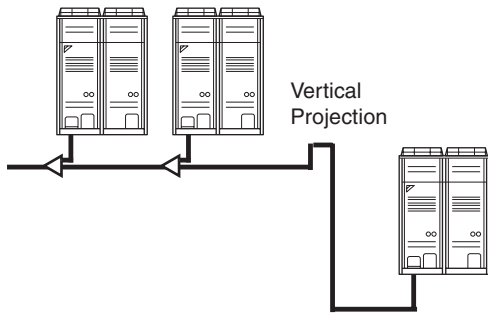

Good

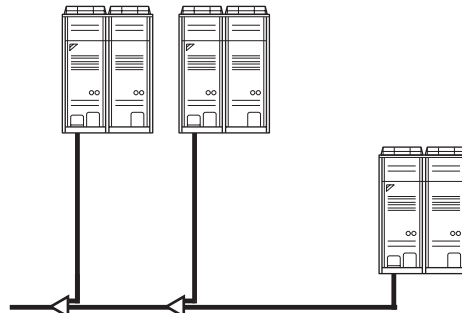

(V3040)

Max. allowable Piping Length	Outdoor Unit - Multi Connection Piping Kit	Actual piping length 10m or less, equivalent length 13m or less
	Multi Connection Piping Kit - Indoor Unit	Actual piping length 165m or less, equivalent length 190m or less, the total extension 1000m or less
	REFNET Joint - Indoor Unit	Actual piping length 40m or less (Refer to Page 285, 286 Note 2 in case of up to 90m)
Allowable Level Difference	Outdoor Unit - Outdoor Unit	5m or less
	Outdoor Unit - Indoor Unit	50m or less ★ 90m or less (when an outdoor unit is lower than indoor units: 40m or less in case of RX(Y)Q5P)
	Indoor Unit - Indoor Unit	15m or less

Note: ★ Available on request if the outdoor unit is above.

7.3 Example of Connection (R-410A type)

Example of connection

(Connection of 8 indoor units)

- (*1) “ ← ” indicate the Outdoor unit multi connection piping kit
- (*2) In case of multi outdoor system, re-read to the first Outdoor unit multi connection piping kit as seen from the indoor unit.

7.3.1 Branch with Refnet Joint

Heat Pump 50Hz/60Hz, Cooling Only 50Hz (RX(Y)Q5~54P, 50PH)

(Connection of 8 indoor units Heat pump system)

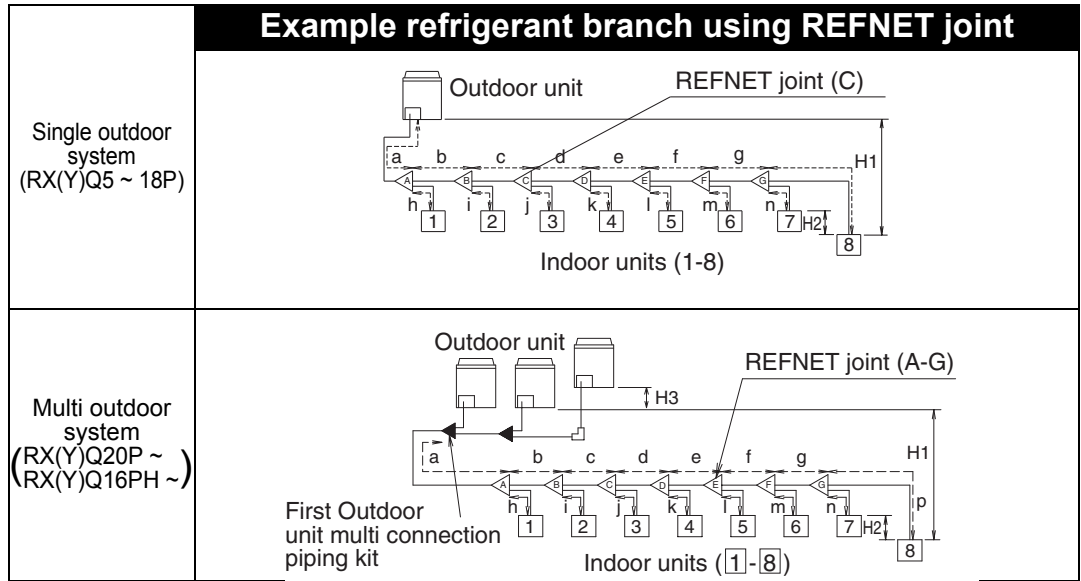

*2 In case of multi outdoor system, re-read to the first Outdoor unit multi connection piping kit as seen from the indoor unit.

Maximum allowable length

Between outdoor (*2) and indoor units

- Actual pipe length
Pipe length between outdoor (*2) and indoor units $\leq 165\text{m}$
Example unit 8: $a + b + c + d + e + f + g + p \leq 165\text{m}$
- Equivalent length
Equivalent pipe length between outdoor (*2) and indoor units $\leq 190\text{m}$ *(See Note 1)
(assume equivalent pipe length of refnet joint to be 0.5m, that of refnet header to be 1m, calculation purposes)
- Total extension length
Total piping length from outdoor unit (*2) to all indoor units $\leq 1000\text{m}$

Between outdoor unit and Outdoor unit multi connection piping kit
(Only for multi system)

- Actual pipe length
Pipe length between outdoor unit and Outdoor unit multi connection piping kit $\leq 10\text{m}$
- Equivalent length
Equivalent length between outdoor unit and Outdoor unit multi connection piping kit $\leq 13\text{m}$

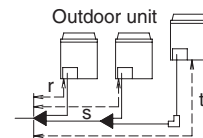

$r \leq 10\text{m}$ (Equivalent length: $\leq 13\text{m}$)
 $s \leq 10\text{m}$ (Equivalent length: $\leq 13\text{m}$)
 $t \leq 10\text{m}$ (Equivalent length: $\leq 13\text{m}$)

Allowable height length

Between outdoor and indoor units

- Difference in height
Difference in height between outdoor and indoor units ($H1$) $\leq 50\text{m}$
($\leq 90\text{m}$ if the outdoor unit is below)

Between indoor and indoor units

- Difference in height
Difference in height between adjacent indoor units ($H2$) $\leq 15\text{m}$

Between outdoor and outdoor units

- Difference in height
Difference in height between outdoor unit ($H3$) $\leq 5\text{m}$

Allowable length after the branch

- Actual pipe length
Pipe length from first refrigerant branch kit (either refnet joint or refnet header) to indoor unit $\leq 40\text{m}$
*(See Note 2)
Example unit 8: $b + c + d + e + f + g + p \leq 40\text{m}$ *(See Note 2)



Refer Note 1 and Note 2 on page 143, 144.

7.3.2 Branch with Refnet Joint and Refnet Header

Heat Pump 50Hz/60Hz, Cooling Only 50Hz (RX(Y)Q5~54P, 50PH)
 (Connection of 8 indoor units Heat pump system)

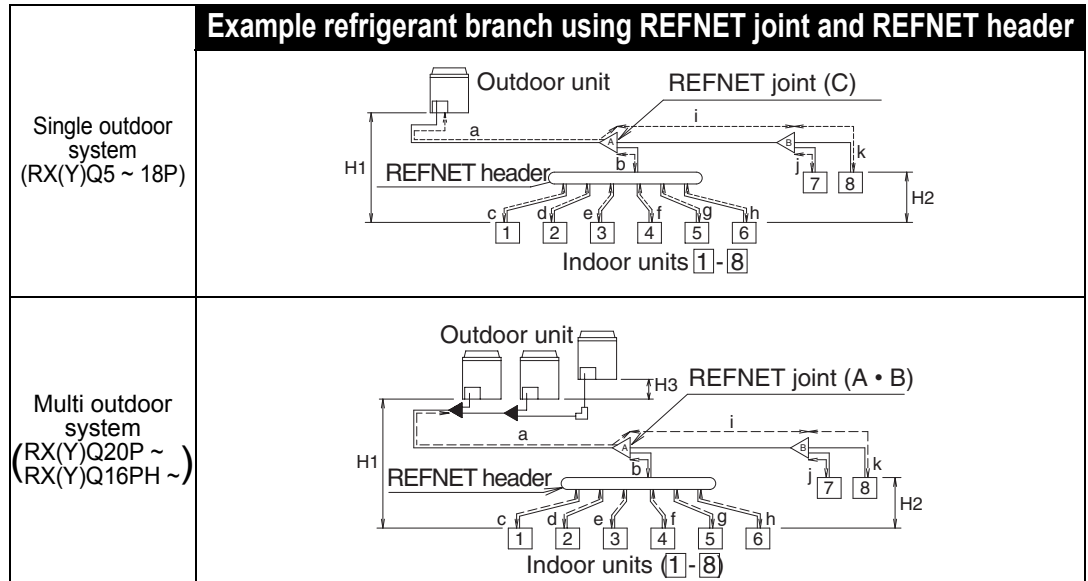

*2 In case of multi outdoor system, re-read to the first Outdoor unit multi connection piping kit as seen from the indoor unit.

Maximum allowable length

- Between outdoor (*2) and indoor units
 - Actual pipe length
 - Pipe length between outdoor (*2) and indoor units $\leq 165\text{m}$
 - Example unit 6: $a + b + h \leq 165\text{m}$, unit 8: $a + i + k \leq 165\text{m}$
 - Equivalent length
 - Equivalent pipe length between outdoor (*2) and indoor units $\leq 190\text{m}$ *(See Note 1)
 (assume equivalent pipe length of refnet joint to be 0.5m, that of refnet header to be 1m, calculation purposes)
 - Total extension length
 - Total piping length from outdoor unit (*2) to all indoor units $\leq 1000\text{m}$

Between outdoor unit and Outdoor unit multi connection piping kit
 (Only for multi system)

- Actual pipe length
 - Pipe length between outdoor unit and Outdoor unit multi connection piping kit $\leq 10\text{m}$
- Equivalent length
 - Equivalent length between outdoor unit and Outdoor unit multi connection piping kit $\leq 13\text{m}$

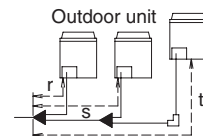

$r \leq 10\text{m}$ (Equivalent length: $\leq 13\text{m}$)
 $s \leq 10\text{m}$ (Equivalent length: $\leq 13\text{m}$)
 $t \leq 10\text{m}$ (Equivalent length: $\leq 13\text{m}$)

Allowable height

- Between outdoor and indoor units
 - Difference in height
 - Difference in height between outdoor and indoor units ($H1$) $\leq 50\text{m}$
 ($\leq 90\text{m}$ if the outdoor unit is below)
- Between indoor and indoor units
 - Difference in height
 - Difference in height between adjacent indoor units ($H2$) $\leq 15\text{m}$
- Between outdoor and outdoor units
 - Difference in height
 - Difference in height between outdoor unit ($H3$) $\leq 5\text{m}$

Allowable length after the branch

- Actual pipe length
 - Pipe length from first refrigerant branch kit (either refnet joint or refnet header) to indoor unit $\leq 40\text{m}$
 - *(See Note 2)
 - Example unit 6: $b + h \leq 40\text{m}$, unit 8: $i + k \leq 40\text{m}$ *(See Note 2)



Refer Note 1 and Note 2 on page 143, 144.

7.3.3 Branch with Refnet Header

Heat Pump 50Hz/60Hz, Cooling Only 50Hz (RX(Y)Q5~54P, 50PH)

(Connection of 8 indoor units Heat pump system)

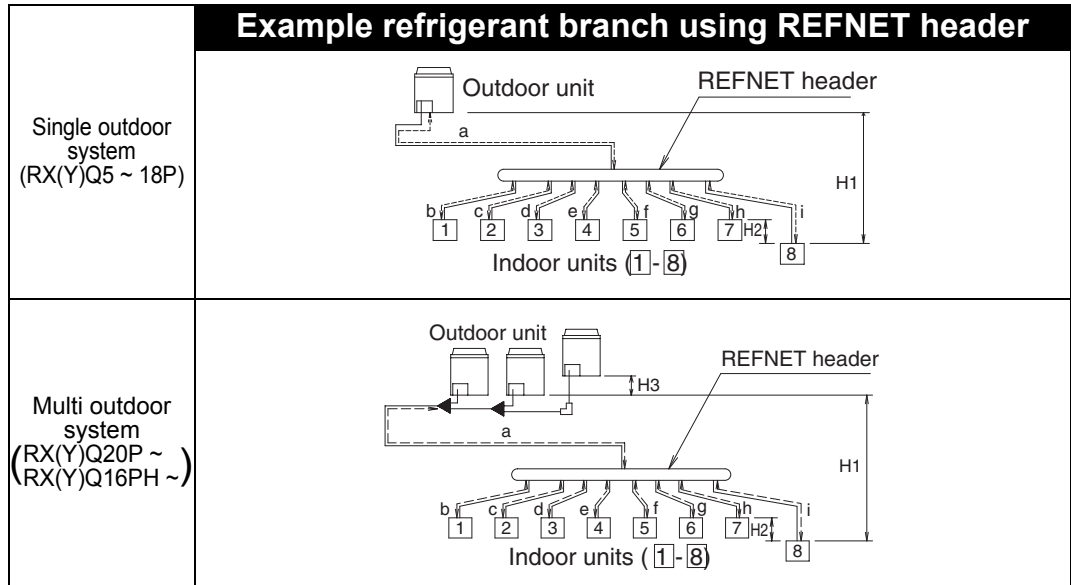

*2 In case of multi outdoor system, re-read to the first Outdoor unit multi connection piping kit as seen from the indoor unit.

Maximum allowable length

Between outdoor (*2) and indoor units

- Actual pipe length
Pipe length between outdoor (*2) and indoor units $\leq 165\text{m}$
Example unit 8: $a + i \leq 165\text{m}$
- Equivalent length
Equivalent pipe length between outdoor (*2) and indoor units $\leq 190\text{m}$ *(See Note 1)
(assume equivalent pipe length of refnet joint to be 0.5m, that of refnet header to be 1m, calculation purposes)
- Total extension length
Total piping length from outdoor unit (*2) to all indoor units $\leq 1000\text{m}$

Between outdoor unit and Outdoor unit multi connection piping kit (Only for multi system)

- Actual pipe length
Pipe length between outdoor unit and Outdoor unit multi connection piping kit $\leq 10\text{m}$
- Equivalent length
Equivalent length between outdoor unit and Outdoor unit multi connection piping kit $\leq 13\text{m}$

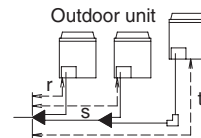

$r \leq 10\text{m}$ (Equivalent length: $\leq 13\text{m}$)
 $s \leq 10\text{m}$ (Equivalent length: $\leq 13\text{m}$)
 $t \leq 10\text{m}$ (Equivalent length: $\leq 13\text{m}$)

Allowable height

Between outdoor and indoor units

- Difference in height
Difference in height between outdoor and indoor units ($H1$) $\leq 50\text{m}$
($\leq 90\text{m}$ if the outdoor unit is below)

Between indoor and indoor units

- Difference in height
Difference in height between adjacent indoor units ($H2$) $\leq 15\text{m}$

Between outdoor and outdoor units

- Difference in height
Difference in height between outdoor unit ($H3$) $\leq 5\text{m}$

Allowable length after the branch

- Actual pipe length
Pipe length from first refrigerant branch kit (either refnet joint or refnet header) to indoor unit $\leq 40\text{m}$
*(See Note 2)
Example unit 8: $i \leq 40\text{m}$



Refer Note 1 and Note 2 on page 143, 144.

7.4 Refrigerant Branch Kit Selection

Refrigerant branch kits can only be used with R-410A.

7.4.1 How to Select the Refnet Joint

Heat Pump 50Hz/60Hz, Cooling Only 50Hz (RX(Y)Q5~54P, 50PH)

- When using REFNET joint at the first branch counted from the outdoor unit side. Choose from the following table in accordance with the outdoor unit capacity type. (Example: REFNET joint A)

Outdoor unit capacity type	Refrigerant branch kit name
5HP type	KHRP26A22T
8, 10HP type	KHRP26A33T
12~22HP type	KHRP26A72T
12~22HP type~	KHRP26A73T + KHRP26M73TP

- Choose the REFNET joints other than that for the first branch from the following table in accordance with the total capacity index of all the indoor units connected below the REFNET joint.

Indoor unit total capacity index	Refrigerant branch kit name
< 200	KHRP26A22T
200 ≤ x < 290	KHRP26A33T
290 ≤ x < 640	KHRP26A72T
640 ≤	KHRP26A73T + KHRP26M73TP

*Example of downstream indoor units

- example in case of refnet joint C; indoor units 3 + 4 + 5 + 6 + 7 + 8,

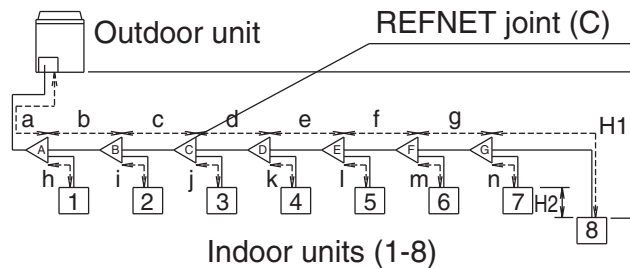

- example in case of refnet joint B indoor units 7 + 8
example in case of refnet joint header; indoor units 1 + 2 + 3 + 4 + 5 + 6

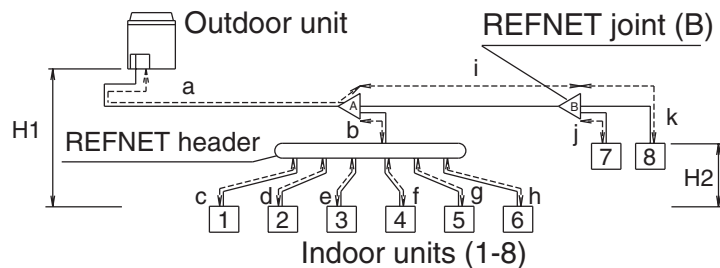

- example in the case of refnet header; indoor units 1 + 2 + 3 + 4 + 5 + 6 + 7 + 8

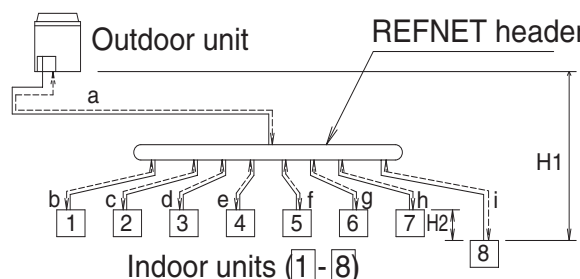

7.4.2 How to Select the Refnet Header (Heat Pump/Cooling Only RX(Y)Q5~54P, 50PH)

- Choose from the following table in accordance with the total capacity of all the indoor units connected below the REFENT header.
- Note: 250 type cannot be connected below the REFENT header.

Indoor unit total capacity index	Refrigerant branch kit name
< 200	KHRP26M22H (Max. 4 branch)
200 ≤ x < 290	KHRP26M33H (Max. 8 branch)
290 ≤ x < 640	KHRP26M72H (Max. 8 branch) (See Note 3 - Next page)
640 ≤	KHRP26M73H (Max. 8 branch) + KHRP26M73HP

*Example of downstream indoor units

1. example in case of refnet joint C; indoor units 3 + 4 + 5 + 6 + 7 + 8

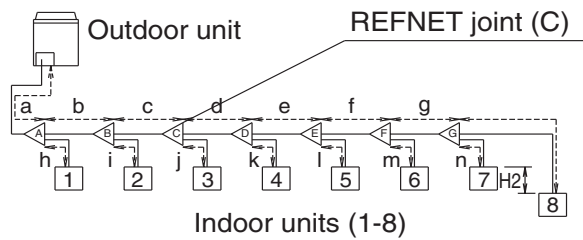

2. example in case of refnet joint B indoor units 7 + 8,
example in case of refnet header ; indoor units 1 + 2 + 3 + 4 + 5 + 6

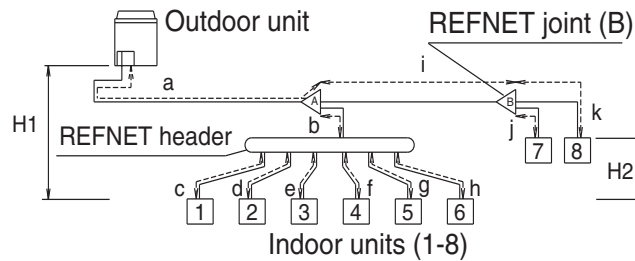

3. example in the case of refnet header; indoor units 1 + 2 + 3 + 4 + 5 + 6 + 7 + 8

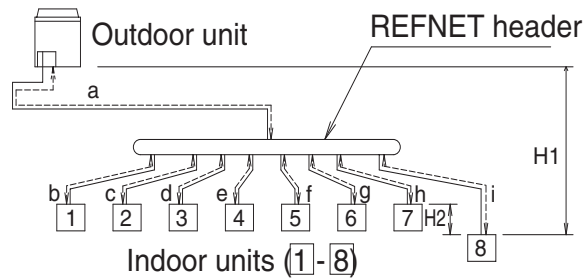

7.4.3 How to Select the Outdoor Unit Multi Connection Piping Kit (This is Required when the System is Multi Outdoor Unit System.)

Heat Pump 50Hz/60Hz, Cooling Only 50Hz

- Choose from the following table in accordance with the number of outdoor units.

Number of outdoor units	Connection piping kit name
2 units	BHFP22P100
3 units	BHFP22P151

7.5 Pipe Size Selection

7.5.1 Heat Pump 50Hz/60Hz, Cooling Only 50Hz (RX(Y)Q5~54P, 50PH)

Pipe size selection

⚠ Caution

The thickness of the pipes in the table shows the requirements of Japanese High Pressure Gas Control law. (As of Jan. 2003)
The thickness and material shall be selected in accordance with local code.

For the multi outdoor unit system, select in accordance with the following figure.

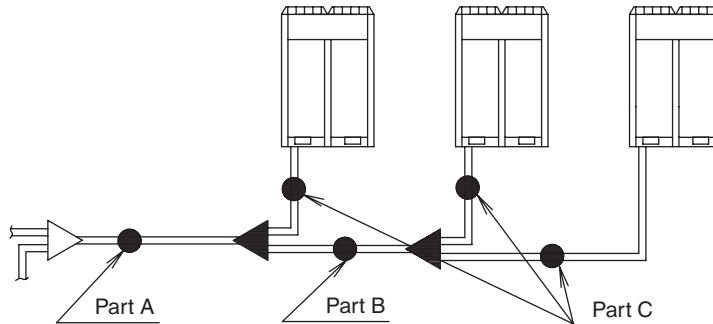

Piping between Outdoor unit and first refrigerant branch kit.

Piping between first Outdoor unit multi connection piping kit and first refrigerant branch kit. (Part A)

- Choose from the following table in accordance with the outdoor unit capacity type.

Piping between Outdoor unit multi connection piping kits. (Part B)

Piping between outdoor unit and Outdoor unit multi connection piping kit. (Part C)

- Choose from the following table in accordance with the total capacity type of all the outdoor units connected above Outdoor unit multi connection piping kit.

(Unit:mm)

Outdoor unit capacity type	Piping size (O.D.)	
	Gas pipe	Liquid pipe
5HP type	φ15.9	φ9.5
8HP type	φ19.1	
10HP type	φ22.2	
12~16HP type	φ28.6	φ12.7
18~22HP type		φ15.9
24HP type	φ34.9	φ19.1
26~34HP type		
36~54HP type	φ41.3	

(See 7.7 Note 1)

Temper grade and wall thickness for pipes.

(Temper grade, O type and 1/2H type indicate the material types specified in JIS H 3300.)

(Unit:mm)

Temper grade	O Type				1/2H Type							
Copper tube O.D	φ6.4	φ9.5	φ12.7	φ15.9	φ19.1	φ22.2	φ25.4	φ28.6	φ31.8	φ34.9	φ38.1	φ41.3
Copper tube W.T (Minimum requirement)	0.80	0.80	0.80	0.99	0.80	0.80	0.88	0.99	1.10	1.21	1.32	1.43

Piping between refrigerant branch kits

- Choose from the following table in accordance with the total capacity index of all the indoor units connected below this.
- Do not let the connection piping exceed the main refrigerant piping size.

(Unit:mm)

Indoor unit total capacity index	Piping size (O.D.)	
	Gas pipe	Liquid pipe
< 150	φ15.9	φ9.5
150 ≤ x < 200	φ19.1	
200 ≤ x < 290	φ22.2	
290 ≤ x < 420	φ28.6	φ12.7
420 ≤ x < 640		φ15.9
640 ≤ x < 920	φ34.9	φ19.1
920 ≤	φ41.3	

Piping between refrigerant branch kit and indoor unit

- Match to the size of the connection piping on the indoor unit.

(Unit:mm)

Indoor unit capacity type	Piping size (O.D.)	
	Gas pipe	Liquid pipe
20 · 25 · 32 · 40 · 50 type	φ12.7	φ6.4
63 · 80 · 100 · 125 type	φ15.9	φ9.5
200 type	φ19.1	
250 type	φ22.2	

7.6 How to Calculate the Additional Refrigerant to be Charged

7.6.1 Heat Pump 50Hz/60Hz, Cooling Only 50Hz (RX(Y)Q5~54P, 50PH)

Additional refrigerant to be charged R (Kg)
 R should be rounded off in units of 0.1Kg.

i Note: If a negative result is gotten for R from the formula below, no refrigerant needs to be added.

$$R = \left(\begin{array}{l} \text{Total length (m)} \\ \text{of liquid piping} \\ \text{size at } \phi 22.2 \end{array} \right) \times 0.37 + \left(\begin{array}{l} \text{Total length (m)} \\ \text{of liquid piping} \\ \text{size at } \phi 19.1 \end{array} \right) \times 0.26 + \left(\begin{array}{l} \text{Total length (m)} \\ \text{of liquid piping} \\ \text{size at } \phi 15.9 \end{array} \right) \times 0.18 + \left(\begin{array}{l} \text{Total length (m)} \\ \text{of liquid piping} \\ \text{size at } \phi 12.7 \end{array} \right) \times 0.12$$

$$+ \left(\begin{array}{l} \text{Total length (m)} \\ \text{of liquid piping} \\ \text{size at } \phi 9.5 \end{array} \right) \times 0.059 + \left(\begin{array}{l} \text{Total length (m)} \\ \text{of liquid piping} \\ \text{size at } \phi 6.4 \end{array} \right) \times 0.022$$

*Example for refrigerant branch using refnet joint and refnet header for RX(Y)Q34P

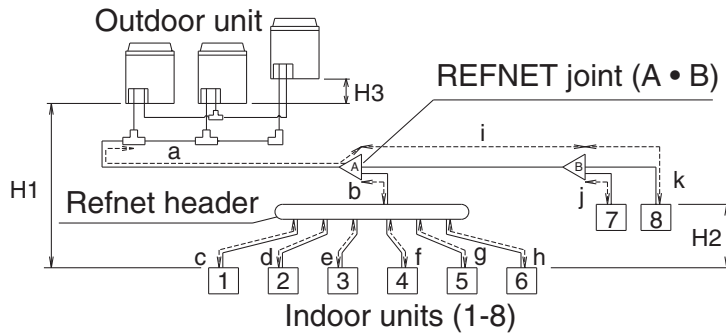

If the outdoor unit is RX(Y)Q34 type and the piping lengths are as at right

a: $\phi 19.1 \times 30\text{m}$	d: $\phi 9.5 \times 10\text{m}$	g: $\phi 6.4 \times 10\text{m}$	j: $\phi 6.4 \times 10\text{m}$
b: $\phi 15.9 \times 10\text{m}$	e: $\phi 9.5 \times 10\text{m}$	h: $\phi 6.4 \times 20\text{m}$	k: $\phi 6.4 \times 9\text{m}$
c: $\phi 9.5 \times 10\text{m}$	f: $\phi 9.5 \times 10\text{m}$	i: $\phi 12.7 \times 10\text{m}$	

$$R = \underset{\substack{\uparrow \\ a}}{30} \times 0.26 + \underset{\substack{\uparrow \\ b}}{10} \times 0.18 + \underset{\substack{\uparrow \\ j}}{10} \times 0.12 + \underset{\substack{\uparrow \\ c+d+e+f}}{40} \times 0.059 + \underset{\substack{\uparrow \\ g+h+j+k}}{49} \times 0.022 = 14.238$$

\downarrow
14.2

i Note: The amount of refrigerant to be added to the unit should be written on the included "Added Refrigerant" plate and attached to the rear side of the front cover. (Refer page 145)

7.7 Size of Main Gas and Liquid Pipes and Allowable Length

7.7.1 Heat Pump 50Hz/60Hz, Cooling Only 50Hz (RX(Y)Q5~54P, 50PH)

*Note 1

When the equivalent pipe length between outdoor and indoor units is 90m or more, the size of main pipes (both gas-side and liquid-side) must be increased.

Depending on the length of the piping, the capacity may drop, but even in such case it is able to increase the size of main pipes.

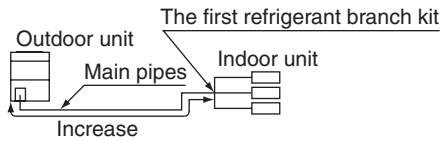

■ Diameter of above case

Model	Gas	Liquid
RX(Y)Q5 Type	φ19.1	Not Increased
RX(Y)Q8 Type	φ22.2	φ12.7
RX(Y)Q10 Type	φ25.4*	φ12.7
RX(Y)Q12 Type	Not Increased	φ15.9
RX(Y)Q14 Type	Not Increased	φ15.9
RX(Y)Q16 Type	φ31.8*	φ15.9
RX(Y)Q18 Type	φ31.8*	φ19.1

Model	Gas	Liquid
RX(Y)Q34 Type	φ38.1*	φ22.2
RX(Y)Q36 Type	Not Increased	φ22.2
RX(Y)Q38 Type	Not Increased	φ22.2
RX(Y)Q40 Type	Not Increased	φ22.2
RX(Y)Q42 Type	Not Increased	φ22.2
RX(Y)Q44 Type	Not Increased	φ22.2
RX(Y)Q46 Type	Not Increased	φ22.2

Model	Gas	Liquid
RX(Y)Q20 Type	φ31.8*	φ19.1
RX(Y)Q22 Type	φ31.8*	φ19.1
RX(Y)Q24 Type	Not Increased	φ19.1
RX(Y)Q26 Type	φ38.1*	φ22.2
RX(Y)Q28 Type	φ38.1*	φ22.2
RX(Y)Q30 Type	φ38.1*	φ22.2
RX(Y)Q32 Type	φ38.1*	φ22.2

Model	Gas	Liquid
RX(Y)Q48 Type	Not Increased	φ22.2
RX(Y)Q50 Type	Not Increased	φ22.2
RX(Y)Q52 Type	Not Increased	φ22.2
RX(Y)Q54 Type	Not Increased	φ22.2

*If available on the site, use this size. Otherwise, it can not be increased.

***Note 2**

Allowable length after the first refrigerant branch kit to indoor units is 40 m or less, however it can be extended up to **90 m** if all the following conditions are satisfied. (In case of “**Branch with REFNET joint**”)

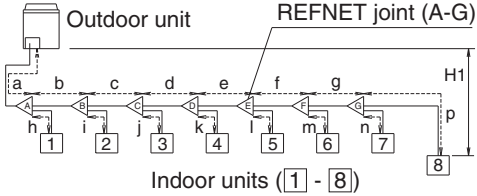
Required Conditions	Example Drawings	
1. It is necessary to increase the pipe size between the first branch kit and the final branch kit. (Reducers must be procured on site) However, the pipes that are same pipe size with main pipe must not be increased.	$\boxed{8} b + c + d + e + f + g + p \leq 90 \text{ m}$ increase the pipe size of b, c, d, e, f, g Increase the pipe size as follows $\phi 9.5 \rightarrow \phi 12.7 \quad \phi 15.9 \rightarrow \phi 19.1 \quad \phi 22.2 \rightarrow \phi 25.4^* \quad \phi 34.9 \rightarrow \phi 38.1^*$ $\phi 12.7 \rightarrow \phi 15.9 \quad \phi 19.1 \rightarrow \phi 22.2 \quad \phi 28.6 \rightarrow \phi 31.8^*$	
2. For calculation of Total extension length, the actual length of above pipes must be doubled. (except main pipe and the pipes that are not increased)		
3. Indoor unit to the nearest branch kit $\leq 40 \text{ m}$		$h, i, j, \dots, p \leq 40 \text{ m}$
4. The difference between [Outdoor unit to the farthest indoor unit] and [Outdoor unit to the nearest indoor unit] $\leq 40 \text{ m}$		The farthest indoor unit $\boxed{8}$ The nearest indoor unit $\boxed{1}$ $(a + b + c + d + e + f + g + p) - (a + h) \leq 40 \text{ m}$
		$a + b \times 2 + c \times 2 + d \times 2 + e \times 2 + f \times 2 + g \times 2 + h + i + j + k + l + m + n + p \leq 1000 \text{ m}$

*If available on the site, use this size. Otherwise it can not be increased.

***Note 3**

If the pipe size above the REFNET header is $\phi 34.9$ or more, KHRP26M73HP is required.

7.8 Record of Field Setting and Additional Refrigerant Charge

Fill the following record and put it on the back side of electrical board.

Request for indication of setting contents, additional refrigerant charging amount and installation date

After filling out the below, please put it on the back side of an ex-board.

1. Record for setting contents for the setting contents of ㊦ ~ ㊨ in the [setting mode 2.] mark ○ in the right table.

㊦ Night - Time low noise setting	OFF • Level 1 • Level 2 • level 3
㊧ External low noise level setting	Level 1 • Level 2 • level 3
㊨ Demand level setting	Level 1 • Level 2 • level 3
㊩ External low noise demand setting	OFF • ON
㊪ High static pressure setting	OFF • ON

2. Record for additional refrigerant charging amount make sure to record the additional refrigerant charging amount. (If do not use automatic refrigerant charging, calculated and charge the additional refrigerant charging amount following as shown on the below.)

Additional charging amount kg	Refrigerant amount for field piping			
	Liquid pipe size (mm)	Refrigerant amount per 1m (kg/m)	Length of liquid pipe (m)	Total
(Round off to one decimal place.)	∅ 22.2	0.37	X	=
	∅ 19.1	0.26	X	=
	∅ 15.9	0.18	X	=
	∅ 12.7	0.12	X	=
	∅ 9.5	0.059	X	=
	∅ 6.4	0.022	X	=

3. Record of installation date DA . MO . YR

3P176431

7.9 Outdoor Unit Multi Connection Piping Kit

7.9.1 BHFP22P100 · 151

Component parts ■ This kit contains the following parts. <Do not throw away any of the accessories until installation is complete>

Kit name	Shape					insulating tube for gas pipe	insulating tube for liquid pipe
	Gas-side joint	Liquid-side joint	Gas-side reducer		Liquid-side reducer		
BHFP 22 P100			(1)	(2)	(1)	Big 1 pc	Small 1 pc
			(3)	(7)	(3)		
BHFP 22 P151			(1)	(2)	(1)	Big 2 pc	Small 2 pc
			(3)	(4)	(2)		
			(5)	(6)	(7)		
			(8)	(9)	(10)		
					(4)		
					(5)		

Caution • Please be sure to read this manual before installation and follow the instruction carefully when performing installation work.
 • See the outdoor unit's installation manual for outdoor unit installation.
 • Installation of interconnecting piping between the outdoor units, REFNET joint or REFNET header will be needed separately

Selection Procedure

Number of outdoor units connected	2 units	3 units
Outdoor unit Multi Connection Piping Kit	BHFP22P100	BHFP22P151

- 2 or 3 outdoor units can be connected.
- There are restrictions on the combination and the installation order of outdoor units, so please refer to "the Engineering Data of VRV III" and "the installation manual" (attached sheet of outdoor unit) for details.

Field supply parts

■ The following parts are needed to connect this kit and are not included

Field supply parts		
Name	Q'ty	Selection Procedure
Insulation for piping	1set	See the "Connecting Pipe Sizes and location of cutting the joint" for details on the necessary size.
Connection piping		
Elbow	1pc	Prepare a gas pipe diameter for the upper outdoor unit as listed in "Connecting Pipe Size and location of cutting the joint."
Tape	1set	For insulation materials

Caution

- Quantity and selection procedure of elbow only applies to a front or bottom connection.
- For a lower front connection the quantity and selection procedure are different, so please refer to the instructions for a lower front connection.
- A joint for the same diameter pipes is needed only for a bottom connection. See the instructions for the bottom connection, for details on quantity and specifications.
- The min. thickness of the pipes in this manual shows the requirements of Japanese High Pressure Gas Control law. (As of Jan. 2003)
- And the temper grade (O,1/2H) shows the material type of JIS h 3300. The tickness and material shall be selected in accordance with local for the design pressure 4.0MPa (40bar).

(Unit : mm)

Temper grade	O Type					1/2H Type						
Copper tube O.D.	Ø 6.4	Ø 9.5	Ø 12.7	Ø 15.9	Ø 19.1	Ø 22.2	Ø 25.4	Ø 28.6	Ø 31.8	Ø 34.9	Ø 38.1	Ø 41.3
Copper tube W.T. (Minimum requirement)	Ø 0.80	Ø 0.80	Ø 0.80	Ø 0.99	Ø 0.80	Ø 0.80	Ø 0.88	Ø 0.99	Ø 1.10	Ø 1.21	Ø 1.31	Ø 1.43

⚠ To the piping installer When installing this kit, please apply the following restrictions

Restrictions on Installing Multi Connection Piping Kit

- Install the joint horizontally so that the caution label attached to joint comes to the top. Do not tilt the joint more than $\pm 15^\circ$. (See Fig. 1). In addition, do not install the joint vertically. (See Fig. 2)
- Make sure the piping up to the joint is straight for more than 500mm. Do not bend the field piping within this range. If a straight field piping more than 120mm is connected, more than 500mm of straight section can be ensured. (See Fig. 3)
- Improper installation may lead to malfunction of the outdoor unit.

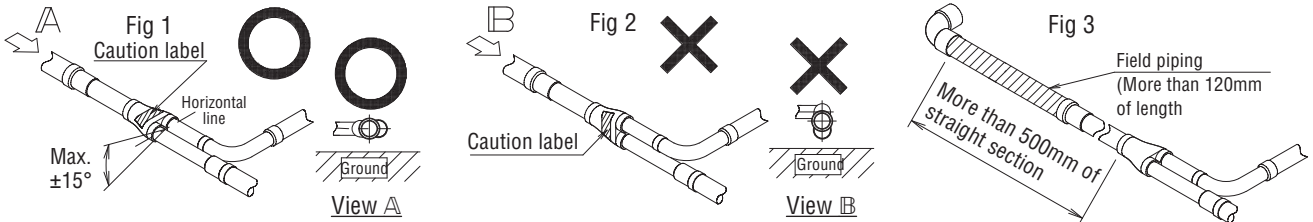

Installation examples

- The figure at the lower shows a typical front connection. Make sure to follow the installation restrictions and carry out installation taking the field requirements into consideration.
- This manual explains the front connection <Ex. of construction 1>.
- For 3-unit installation on Ex. of construction 5 and 6, in some cases the reducers (5), (6) or (10) for gas piping and the reducers (2) and (3) for liquid piping may be used on the 1st joint (section shown with ←). See the figure at the right for details of connection.
- When the size of the Gas-side pipe between the Gas-side joint (1) and Gas-side joint (2) on the 3-units system or the size of the main pipe is $\varnothing 41.3$ or $\varnothing 34.9$. Gas-side reducer (7), (8) and (9) will be used. See the figure at the right for details of connection.
- When the size of the Liquid-side pipe between the Liquid-side joint (1) and Liquid-side joint (2) on the 3-units system is $\varnothing 12.7$. Liquid-side reducer (3) will be used. And when the side of main pipe is $\varnothing 15.9$. Liquid-side reducer (4) will be used. See the figure at the right for details of connection.

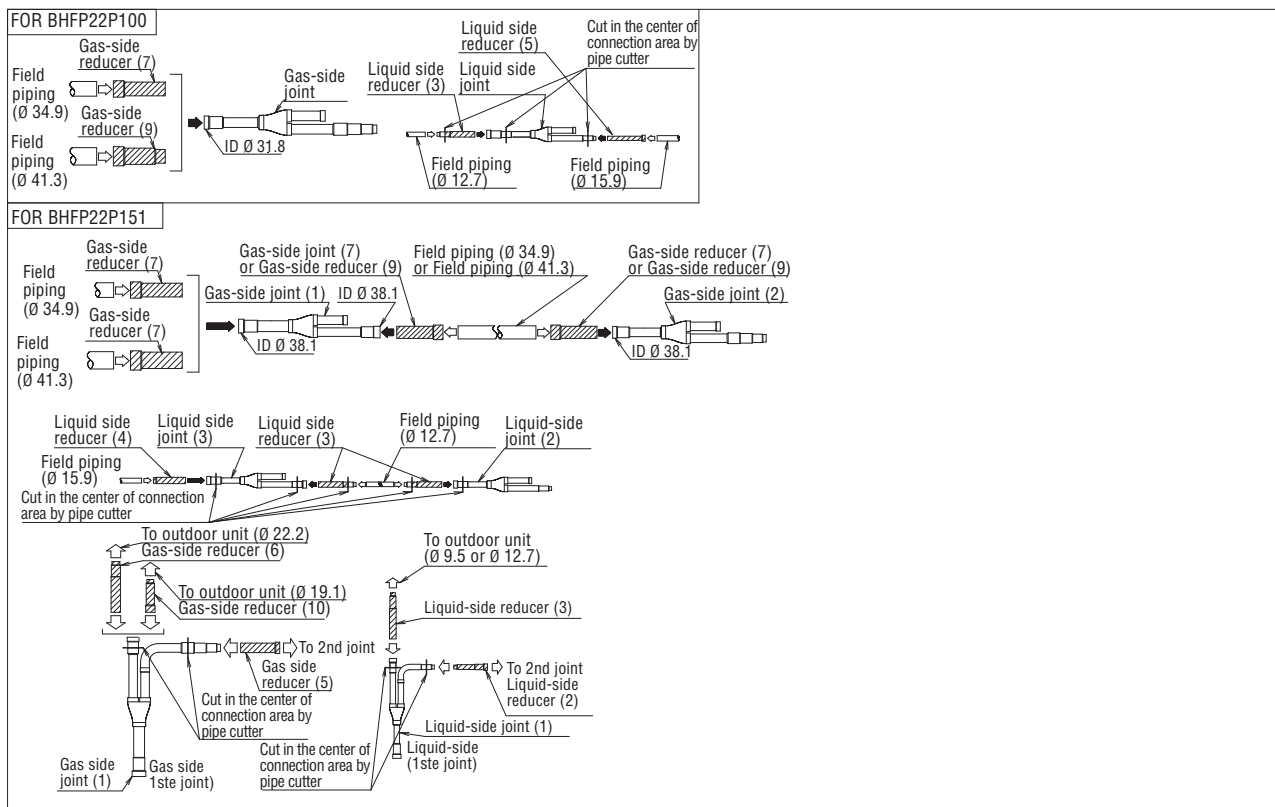
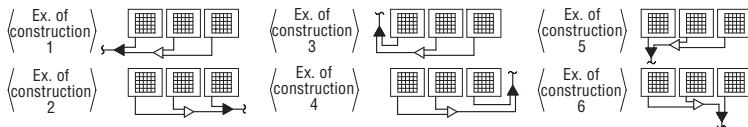

BHFP22P100 Installation Instructions

Caution There are some restrictions on the interconnecting piping between the outdoor units. See the installation attached to the outdoor units and make sure to carry out proper piping. If the piping restrictions are not observed, it may result in malfunction of the unit.

Connecting pipe sizes and location of cutting the joint

Select cutting point of a joint or a reducer which is suitable for the size of the interconnecting pipes determined according to the table below and cut it with a pipe cutter. (units: mm)

Outdoor unit capacity type	Pipe size (O.D. x min. thickness [temper grade])	
	Gas pipe	Liquid pipe
8HP	φ19,1×0,80[1/2H]	φ9,5×0,80[0]
10HP	φ22,2×0,80[1/2H]	
12~16HP	φ28,6×0,99[1/2H]	φ12,7×0,80[0]
18HP		φ15,9×0,99[0]

Follow "Restrictions on installing Multi Connection Piping Kit"

• Select the pipe size according to the total capacity of outdoor unit.

Outdoor unit total capacity type	Pipe size (O.D. x min. thickness [temper grade])	
	Gas pipe	Liquid pipe
16HP	φ28,6×0,99[1/2H]	φ15,9×0,99[0]
18~22HP		
24HP	φ34,9×1,21[1/2H]	φ19,1×0,80[1/2H]
26~34HP		
36HP	φ41,3×1,43[1/2H]	

- When upsizing the main pipe, use the gas side reducer (2)
- If the pipe size of φ19.1 or larger is used, the O material may be insufficient to withstand the specified pressure. Therefore, make sure to use the 1/2H material with thickness of 1.0mm or more. When using the O material for the pipe size of φ19.1, a thickness of 1.2 or more is required. In this case, the connection must be brazed.

Cutting procedure

• Use pipe cutter for cutting

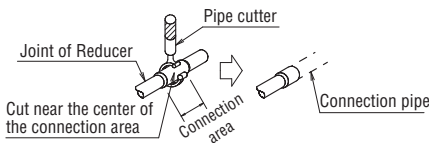

1 Installation examples Procedure for Front Connection

1-1 Exterior view

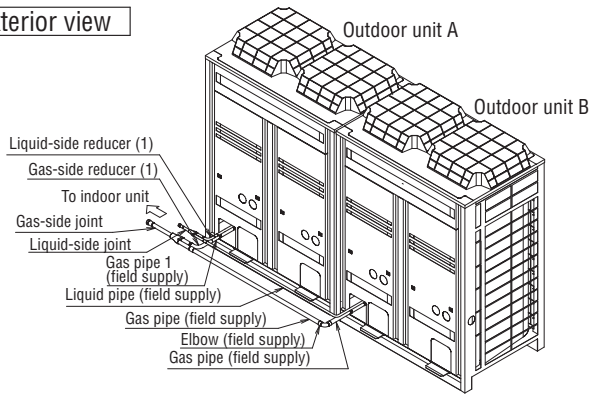

1-2 Finished dimensions

• For installations where the A dimensions exceed 290mm, extend the field supply interconnecting pipe between the joint and the outdoor unit.

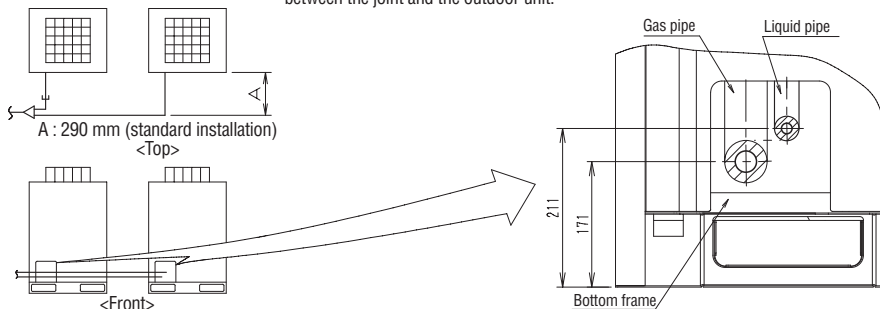

2 Connection of gas and liquid pipes

2-1 Cutting the field supply gas pipes

- Cut the pipes according to Table 1.

Caution • This table shows the case when the A dimensions shown in 1-2 Finished dimensions is 290 mm. If the A dimensions exceed 290 mm, see Table 1 and adjust the dimensions of the gas pipe 1 and 2.
 • The L dimensions of the gas pipe 2 in Table 1 show those when the field supply elbows have B dimension in Table 2. If the B dimension is not same with Table 2, see Table 1 and 2, and adjust them accordingly.

Table 1

Model type	Gas pipe 1 (field supply)		Gas pipe 2 (field supply)	
	L (mm)		L (mm)	
8HP	75		287	
10HP	81		257	
12~18HP	125		223	

Table 2

Model type	Elbow (field supply)	
	B (mm)	
8HP	17	
10HP	23	
12~18HP	29	

2-2 Connection of pipes

- Connect the gas and liquid pipes as shown in the figure at the right. (When connecting the pipes, first connect the gas-side joint and the gas-side reducer (1), the liquid-side joint and the gas-side reducer (1))
- See 1-2 Finished dimensions for the location (height) of the joint.
- See the caution section in the installation manual attached to the outdoor unit for brazing pipes and connecting pipes with flare nuts.
- Install the joint in such a way that the attached face of the caution label becomes horizontal (See the View A)

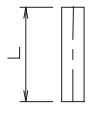
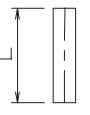
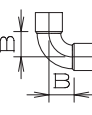
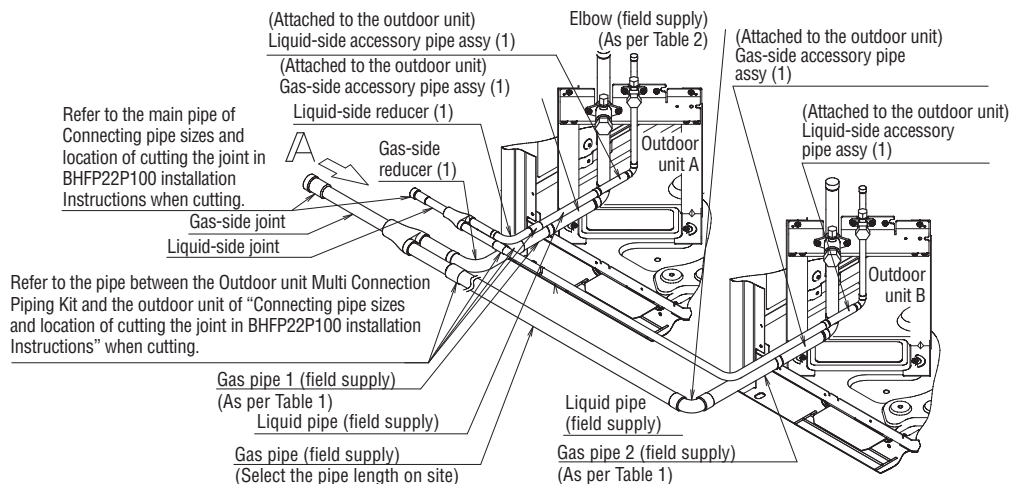
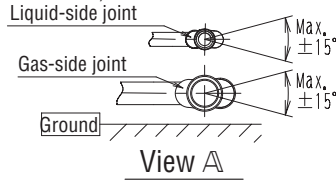

③ The work after the kit is connected

Connection of piping between the outdoor unit and the indoor unit

Air tight test

} Follow the instructions in the installation manual included with the outdoor unit, when performing installation work.

Insulation of joints

- (1) Fit the insulation to the reducer and temporarily keep it in place with tape.
- (2) Fit the insulation to the joint and temporarily keep it in place with tape without leaving a gap between the insulation mating faces. (See the figure at the right.)
- (3) Seal the seam between the insulation and the field supply piping insulation with the field supply tape.
- (4) Wrap the tape around the insulation attached to the joint without leaving a gap.

(// section shown in the figure at the right)

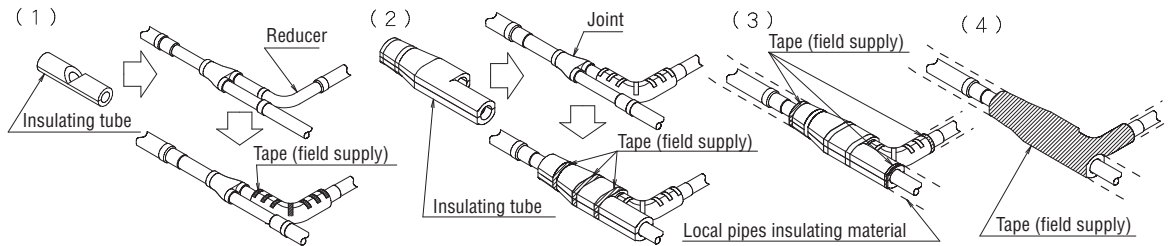

1 Installation examples Prodecure for Lower Front Connection

1-1 Exterior view

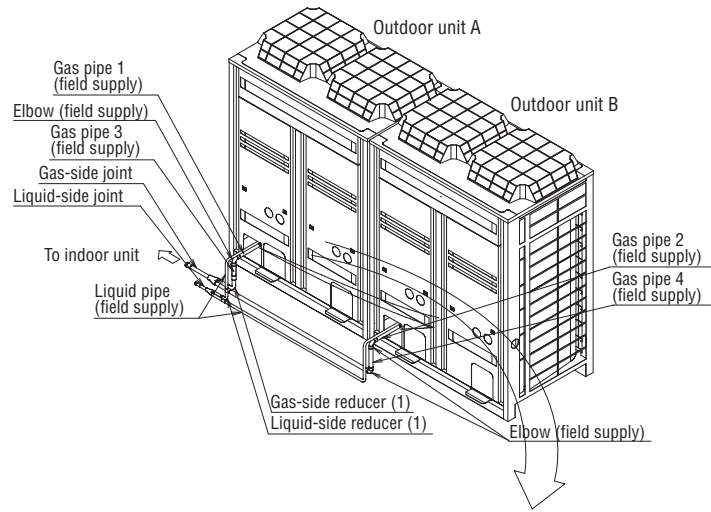

1-2 Finished dimensions

- A standard installation has the following dimensions
- When the dimensions exceed the standard installation, extend the pipes between the outdoor unit and the joint (field supply)

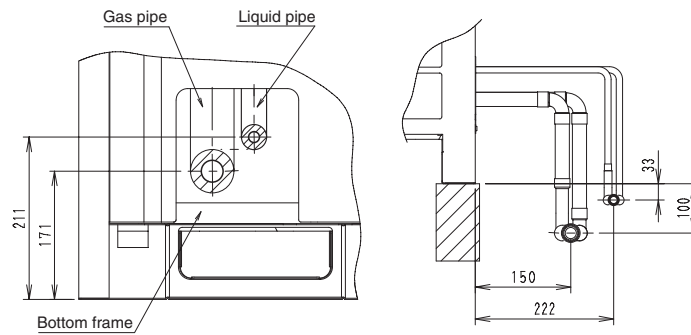

2 Connection of gas and liquid pipes

2-1 Cutting the field supply gas pipe 1 to 4

- Cut the pipes according to Table 3
- CAUTION** • The L dimension of the gas pipe 1 to 4 in Table 3 show those when the field supply elbows have B dimension in Table 2 shown in Procedure for Front Connection, 2 Connection of gas and liquid pipes.
If the B dimensions are not same with Table 2, see Table 2 and 3, and adjust them accordingly.

Table 3

Model type	Gas pipe 1 (field supply)		Gas pipe 2 (field supply)		Gas pipe 3 (field supply)		Gas pipe 4 (field supply)	
	L(mm)		L(mm)		L(mm)		L(mm)	
8HP	130		165		59		237	
10HP	100		135		83		225	
12-18 HP	66		101		149		213	

2-2 Connection of pipes

- Connect the gas and liquid pipes as shown in the figure at the right.
(When connecting the pipes, first connect the gas-side joint and the gas-side reducer(1), the liquid-side joint and the liquid-side reducer (1))
- See the caution section in the installation manual attached to the outdoor unit for brazing pipes and connecting pipes with flare nuts.
- Install the joint in such a way that the attached face of the caution label becomes horizontal (See the View A).

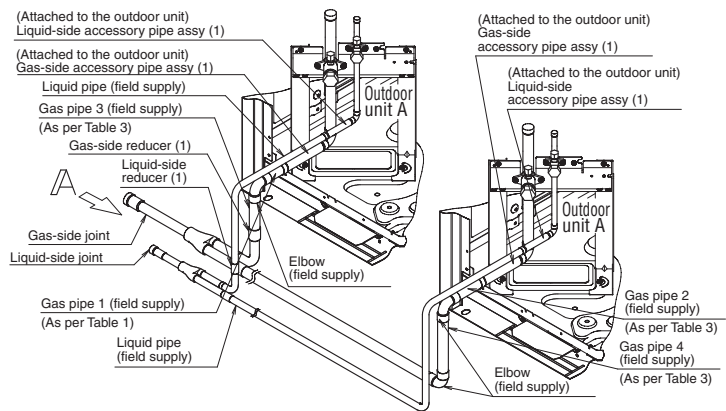
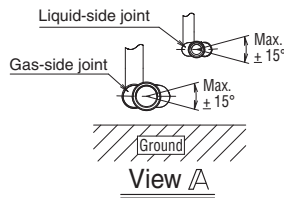

3 The work after the kit is connected

Connection of piping between the outdoor unit and the indoor unit

Follow the instructions in the installation manual included with the outdoor unit, when performing installation work.

Air tight test

Insulation of joints

- (1) Fit the insulation to the reducer and temporarily keep it in place with tape.
- (2) Cut insulating tube along the slit. (See the figure at the right.)
Fit the insulation to the joint and temporarily keep it in place with tape without leaving a gap between the insulation mating faces.
- (3) Seal the seam between the insulation and the field supply piping insulation with the field supply tape.
- (4) Wrap the tape around the insulation attached to the joint without leaving a gap.
(section shown in the figure at the right.)

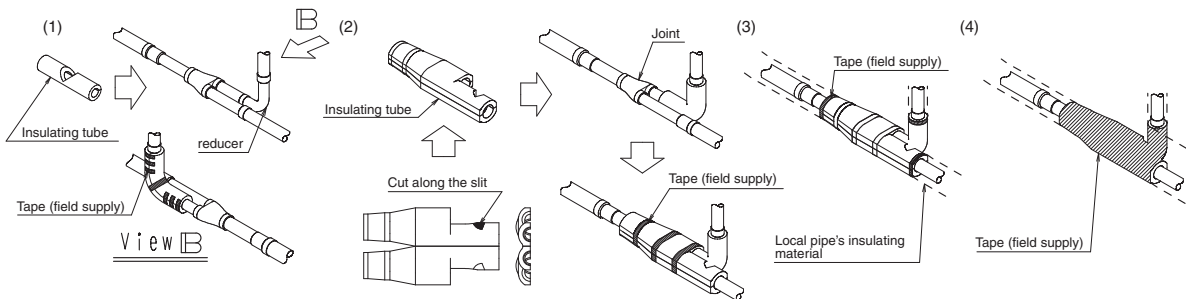

1 Installation examples Procedure for Bottom Connection

CAUTION This installation is only possible if there is enough space to perform brazing and racking underneath the outdoor unit. If a centralized drain pan kit and/or vibration proof base are used, the dimensions marked with "*" in the figure below will vary, so see the table below and determine the length of the field pipes

1-1 Exterior view

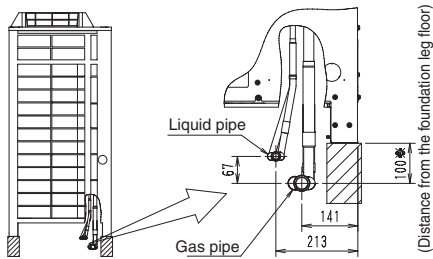

Seperately-sold item also used	* dimensions
Central drain pan kit	139
Vibration absorption stand	233
Vibration absorption stand + central drain pan kit	

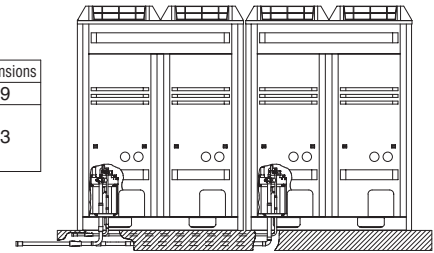

2 Connection of gas and liquid pipes

2-1 Cutting the field supply gas pipe 1 and 2 and the Gas-side accessory pipe (3) attached to the outdoor unit

• Cut the pipes according to Table 4 or 5.
CAUTION • The "L" dimension of the gas pipe 1 in Table 4 and the gas pipe 2 in Table 5 are identical to the "B" dimensions in table 2, those of "field supply elbows" shown in the procedure of front connection, which are equivalent to "straight size joint" without stopper. If the "B" dimensions are not identical to table 2 or "straight size joint" is with stopper, adjust them as table 2, 4 and 5 show

■ Table 4 (For Outdoor unit A Side)

Model type	Gas-side accessory pipe (3)			cutting position M	Gas-pipe 1 (field supply)			cutting position M
	B (mm)				L (mm)			
	* dimensions				* dimensions			
	For 100	For 139	For 233		For 100	For 139	For 233	
8HP	102	63	48		 unnecessary	79	86	
10HP	72	33	25					
12HP ~ 18HP	0 (no cutting)	53	0 (no cutting)			92	133	

■ Table 5 (For outdoor unit B Side)

Model type	Gas-side accessory pipe (3)			cutting position M	Gas-pipe 2 (field supply)			cutting position M
	B (mm)				L (mm)			
	dimensions				* dimensions			
	For 100	For 139	For 233		For 100	For 139	For 233	
8HP	0 (no cutting)	0 (no cutting)	0 (no cutting)		76	115	209	
10HP	18	0 (no cutting)	0 (no cutting)		88	109	203	
12HP ~ 18HP	32	0 (no cutting)	0 (no cutting)		96	103	197	

2-2 Connection of pipes

- Remove the knockout plate on the bottom frame. (See the installation manual attached to the outdoor unit)
- Connect the gas and liquid pipe as shown in the figure below. (When connecting the pipes, first connect the gas-side joint and the gas-side reducer (1), the liquid-side joint and the liquid-side reducer (1)).
- See the caution section in the installation manual attached to the outdoor unit for brazing pipes and connecting pipes with flare nuts.
- Install the joint in such a way that the attached face of the caution label becomes horizontal. (See the view A)
- Connect the liquid side reducer (1) tilting approx. 10° and bend the field supplied liquid pipe up to the stop valve as shown in the figure below. (See the view A)

CAUTION • If the liquid side reducer is connected vertically without bending the liquid pipes, the insulation will not fit.

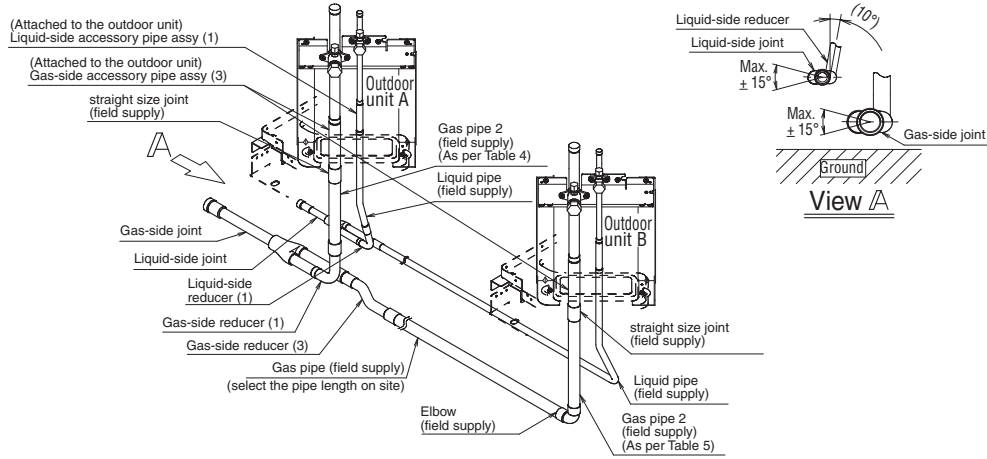

3 The work after the kit is connected

Connection of piping between the outdoor unit and the indoor unit

Follow the instructions in the installation manual included with the outdoor unit, when performing installation work.

Air tight test

Insulation of joints

- (1) Fit the insulation to the reducer and temporarily keep it in place with tape.
- (2) Cut insulating tube along the slit. (See the figure at the right.)
Fit the insulation to the joint and temporarily keep it in place with tape without leaving a gap between the insulation mating faces.
- (3) Seal the seam between the insulation and the field supply piping insulation with the field supply tape.
- (4) Wrap the tape around the insulation attached to the joint without leaving a gap.
(Hatched section shown in the figure at the right.)

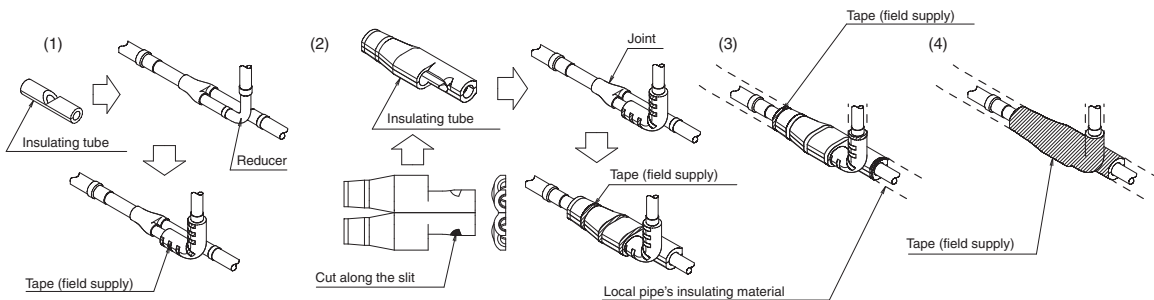

BHFP22P151 Installation Instructions

CAUTION There are some restrictions on the interconnecting piping between the outdoor units. See the installation manual attached to the outdoor units and make sure to carry out proper piping. If the piping restrictions are not observed, it may result in malfunction of the unit.

Connecting Pipe Sizes and location of cutting the joint

Select cutting point of a joint or a reducer which is suitable for the size of the interconnecting pipes determined according to the table below and cut it with a pipe cutter.

Pipe between outdoor unit Multi Connection Piping Kit
Select the pipe size according to the total capacity of the outdoor unit (unit B, C).

Main pipe
Select the pipe size according to the total capacity of the outdoor unit to be connected upstream (unit A, B, C)

Outdoor unit capacity type	Pipe size (O.D. x min. thickness [temper grade]) (units:mm)	
	Gas pipe	Liquid pipe
8HP	Ø19.1x0.80[1/2H]	Ø 9.5x0.80[0]
10 HP	Ø22.2x0.80[1/2H]	Ø12.7x0.80[0]
12-16HP	Ø28.6x0.99[1/2H]	Ø15.9x0.99[0]
18HP	Ø34.9x1.21[1/2H]	Ø19.1x0.80[1/2H]

Outdoor Unit Multi Connecting Piping Kit
Follow "Restrictions on Installing Multi Connection Piping Kit"

Outdoor unit total capacity (unit A, B,C) or the total capacity of the outdoor unit to be connected upstream (unit B, C)	Pipe size (O.D. x min. thickness [temper grade]) (units:mm)	
	Gas pipe	Liquid pipe
16HP	Ø28.6x0.99[1/2H]	Ø 12.7x0.80[0]
18-22HP	Ø34.9x1.21[1/2H]	Ø15.9x0.99[0]
24HP	Ø41.3x1.43[1/2H]	Ø19.1x0.80[1/2H]
26-34HP	Ø41.3x1.43[1/2H]	Ø19.1x0.80[1/2H]
36HP	Ø41.3x1.43[1/2H]	Ø19.1x0.80[1/2H]

Cutting procedure

- Use pipe cutter for cutting

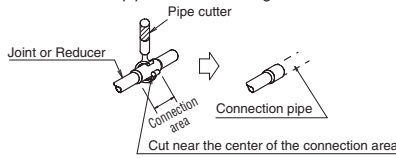

1 Installation examples Procedure for Front Connection

1-1 Exterior view

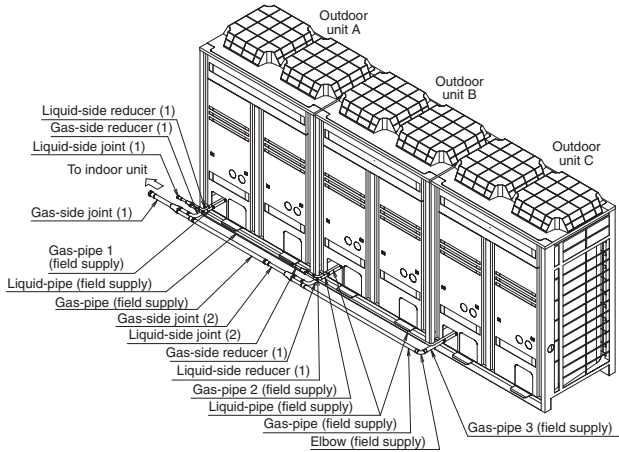

1-2 Finished dimensions

- For installations where the A dimensions exceed 284 mm, extend the field supply interconnecting pipe between the joint and the outdoor unit.

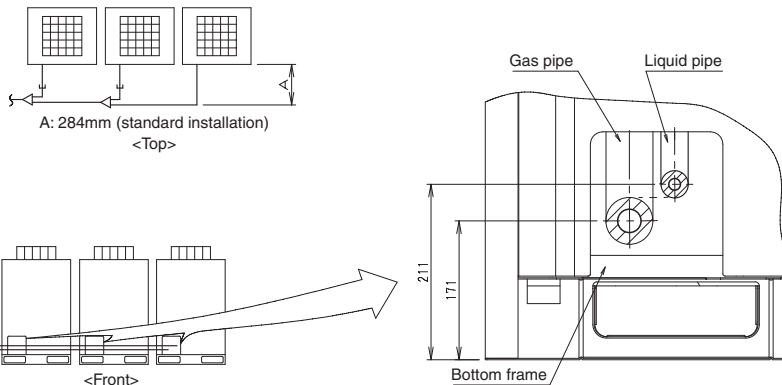

2 Connection of gas and liquid pipes

2-1 Cutting the field supply gas pipes













- Cut the pipes according to Table 6.

CAUTION • This table shows the case when the A dimensions shown in "1-2 Finished dimensions" is 284mm. If the A dimensions exceed 284mm, see Table 6 and adjust the dimensions of the gas pipe 1 and 2 and 3.

- The L dimensions of the gas pipe 3 in Table 6 show those when the field supply elbows have B dimension in Table 2 shown in BHFP22P151 Installation instruction, 2 connection of gas and liquid pipes.

If the B dimensions are not the same with Table 2, see Table 2 and 6, and adjust them accordingly

■ Table 6

Model type	Gas pipe 1 (field supply)		Gas pipe 2 (field supply)		Gas pipe 3 (field supply)	
	L(mm)		L(mm)		L(mm)	
8HP	51		69		282	
10HP	57		75		252	
12-18 HP	101		119		218	

2-2 Connection of pipes

- Connect the gas and liquid pipes as shown in the figure at the right.
- When connecting the pipes, first connect the gas-side joint and the gas-side reducer(1), the liquid-side joint and the liquid-side reducer (1)
- See "1-2 Finished dimensions" for the location (height) of the joint.
- See the caution section in the installation manual attached to the outdoor unit for brazing pipes and connecting pipes with flare nuts.
- Install the joint in such a way that the attached face of the caution label becomes horizontal (See the View A).

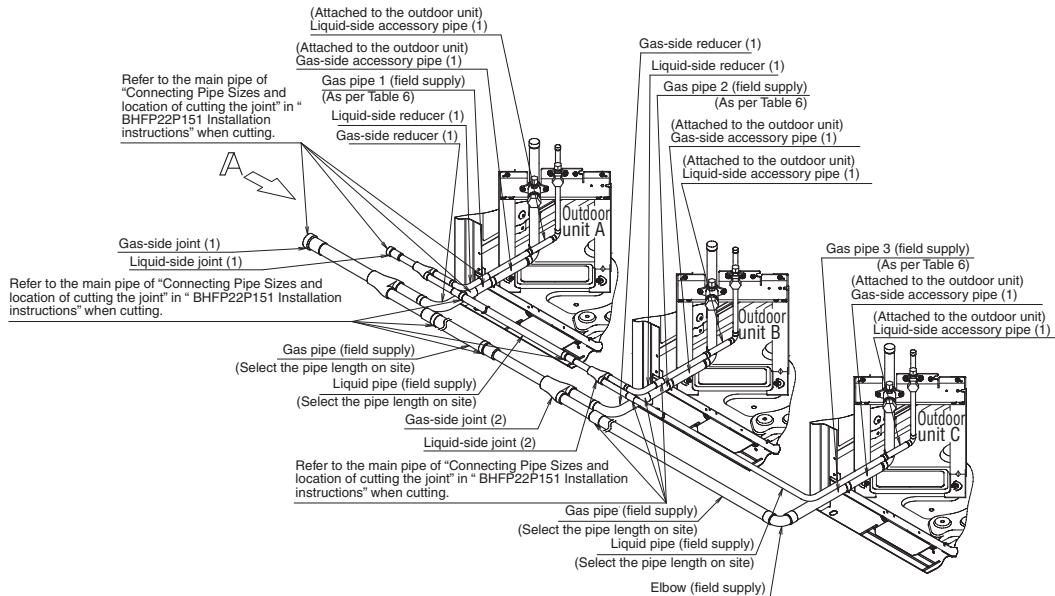
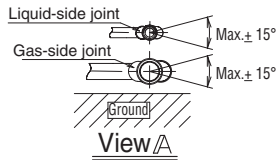

3 The work after the kit is connected

Connection of piping between the outdoor unit and the indoor unit

Follow the instructions in the installation manual included with the outdoor unit, when performing installation work.

Air tight test

Insulation of joints

- See "The work after the kit is connected" for a front connection in "BHFP22P151 Installation Instructions."

1 Installation examples Procedure for Front Connection

1-1 Exterior view

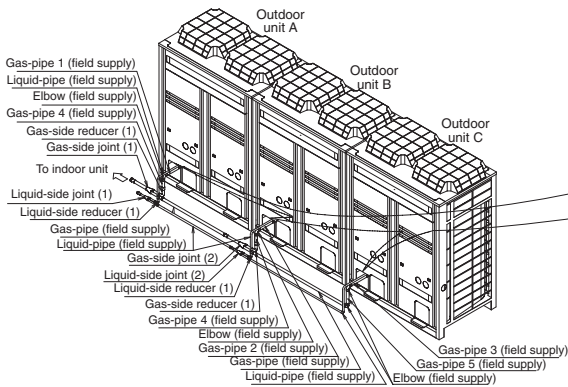

1-2 Finished dimensions

- A standard installation has the following dimensions.
- When the dimensions exceed the standard installation, extend the pipes between the outdoor unit and the joint. (field supply)

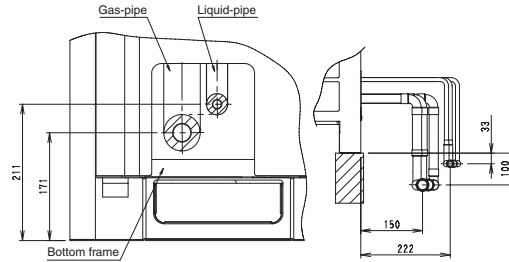

2 Connection of gas and liquid pipes

2-1 Cutting the field supply gas pipes

- Cut the pipes according to Table 7.

CAUTION • The L dimensions of the gas pipe 1 to 5 in Table 7 show those when the field supply elbows have B dimension in Table 2 shown in BHFP22P100 Installation instruction, 2 connection of gas and liquid pipes and the field supply joint for the same diameter pipes are without stopper. If the B dimensions are not the same with Table 2 or the joint for the same diameter pipes have stopper, see Table 2 and 7, and adjust them accordingly.

Table 7

Model type	Gas pipe 1 (field supply)		Gas pipe 2 (field supply)		Gas pipe 3 (field supply)	
	L (mm)		L (mm)		L (mm)	
8HP	130		147		182	
10HP	100		117		152	
12-18 HP	66		83		118	

Model type	Gas pipe 4 (field supply)		Gas pipe 5 (field supply)	
	L (mm)		L (mm)	
8HP	59		237	
10HP	83		225	
12-18 HP	149		213	

2-2 Connection of pipes

- Connect the gas and liquid pipes as shown in the figure at the left.
(When connecting the pipes, first connect the gas-side joint and the gas-side reducer (1), the liquid-side joint and the liquid-side reducer (1).)
- See the caution section in the installation manual attached to the outdoor unit for brazing pipes and connecting pipes with flare nuts.
- Install the joint in such a way that the attached face of the caution label becomes horizontal (See the View A).

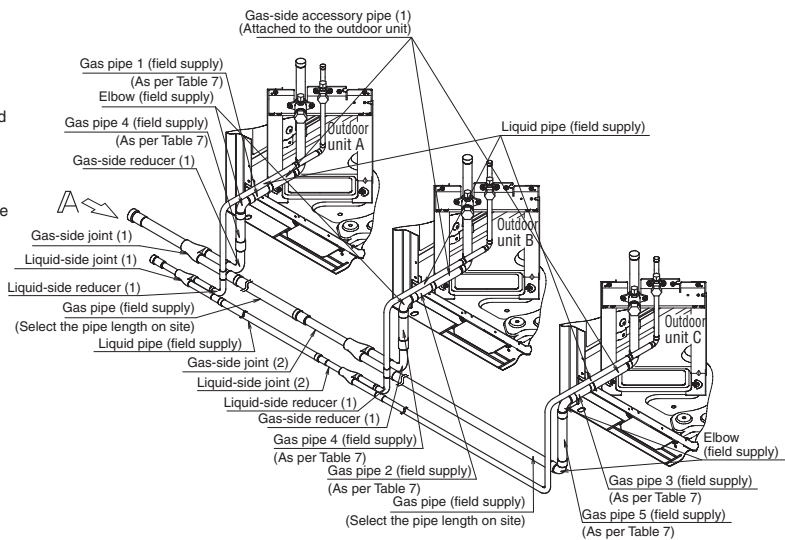
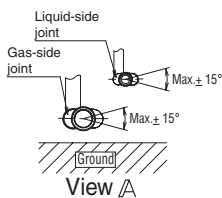

③ The work after the kit is connected

Connection of piping between the outdoor unit and the indoor unit

Air tight test

Insulation of joints

} Follow the instructions in the installation manual included with the outdoor unit, when performing installation work.

- See “The work after the kit is connected” for a lower front connection in “BHFP22P100 Installation Instructions.”

1 Installation examples Procedure for Bottom Connection

CAUTION This installation is only possible if there is enough space to perform brazing and racking underneath the outdoor unit. If a centralized drain pan kit and/or vibration proof base are used, the dimensions marked with "*" in the figure below will vary, so see the table below and determine the length of the field pipes.

1-1 Exterior view

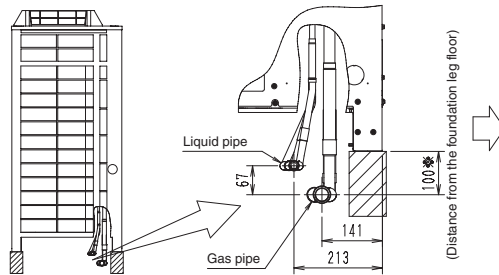

Separately-sold item also used	*dimensions
Central drain pan kit	139
Vibration absorption stand	233
Vibration absorption stand + central drain pan kit	

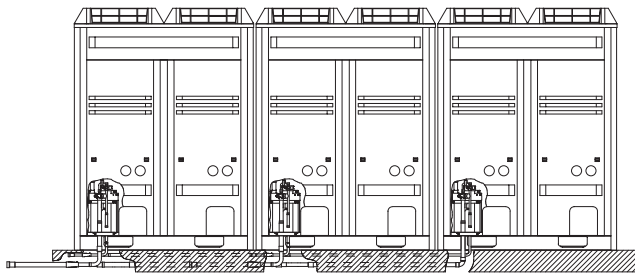

2 Connection of gas and liquid pipes

2-1 Cutting the field supply gas pipe 1 and 2 and the Gas-side accessory pipe (3) attached to the outdoor unit

• Cut the pipes according to Table 8 or 9.

CAUTION • The "L" dimension of the gas pipe 1 in Table 8 and the gas pipe 2 in Table 9 are identical to the "B" dimensions in table 2, those of "field supply elbows" shown in the procedure of front connection, which are equivalent to "straight size joint" without stopper. If the "B" dimensions are not identical to table 2 or "straight size joint" is with stopper, adjust them as table 2, 8 and 9 show.

■ Table 8 (For outdoor unit A, B Side)

Model type	Gas-side accessory pipe (3)			cutting position	Gas-pipe 1 (field supply)			
	B (mm) dimensions				L (mm) dimensions			
	For 100	For 139	For 233		For 100	For 139	For 233	
8HP	102	63	48				79	
10HP	72	33	25		unnecessary			86
12HP ~ 18HP	0 (no cutting)	53	0 (no cutting)			92	133	

■ Table 9 (For outdoor unit C Side)

Model type	Gas-side accessory pipe (3)			cutting position	Gas-pipe 2 (field supply)		
	B (mm) dimensions				L (mm) dimensions		
	For 100	For 139	For 233		For 100	For 139	For 233
8HP	0 (no cutting)	0 (no cutting)	0 (no cutting)				76
10HP	18	0 (no cutting)	0 (no cutting)		88	109	203
12HP ~ 18HP	32	0 (no cutting)	0 (no cutting)		96	103	197

2-2 Connection of pipes

- Remove the knockout plate on the bottom frame. (See the installation manual attached to the outdoor unit)
- Connect the gas and liquid pipe as shown in the figure below. (When connecting the pipes, first connect the gas-side joint and the gas-side reducer (1), the liquid-side joint and the liquid-side reducer (1)).
- See the caution section in the installation manual attached to the outdoor unit for brazing pipes and connecting pipes with flare nuts.
- Install the joint in such a way that the attached face of the caution label becomes horizontal. (See the view A)
- Connect the liquid side reducer (1) tilting approx. 10° and bend the field supplied liquid pipe up to the stop valve as shown in the figure below. (See the view A)

CAUTION • If the liquid side reducer is connected vertically without bending the liquid pipes, the insulation will not fit.

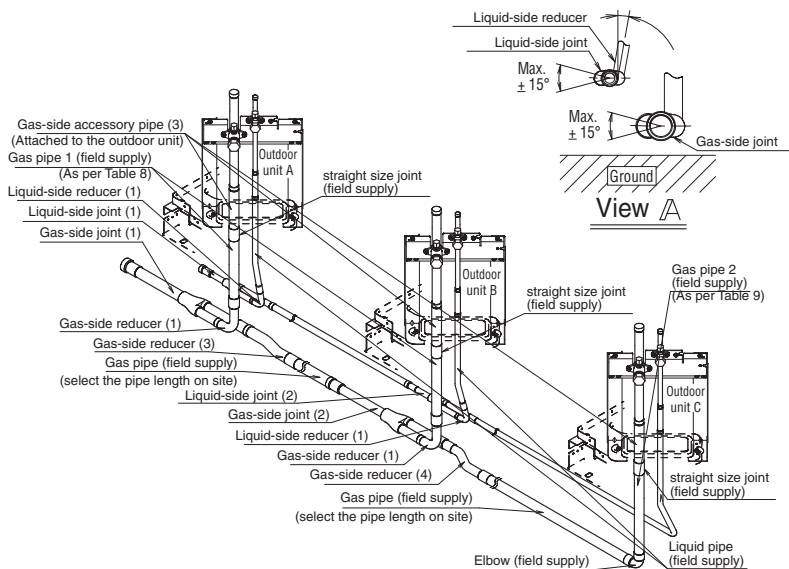

3 The work after the kit is connected

Connection of piping between the outdoor unit and the indoor unit

Air tight test

Insulation of joints

Follow the instructions in the installation manual included with the outdoor unit, when performing installation work.

• See "The work after the kit is connected" for a front connection in "BHFP22P100 Installation Instructions."

7.10 REFNET Joint and Header

7.10.1 REFNET Joint (Branch Kit)

KHRP26A22T

Gas Side

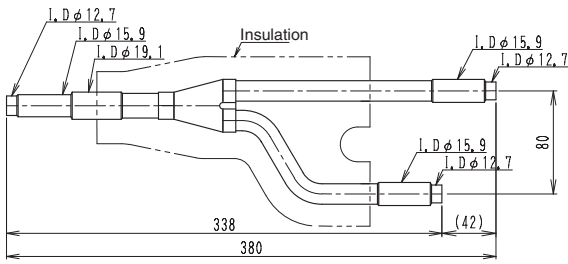

Liquid Side

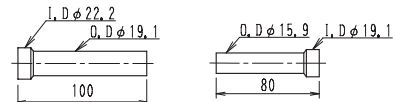
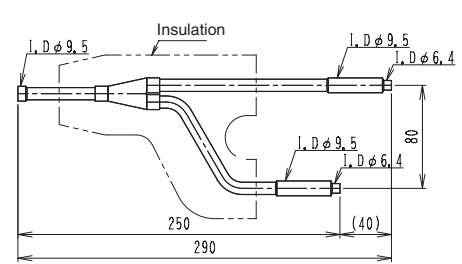

C : D3K05234A

KHRP26A33T

Gas Side

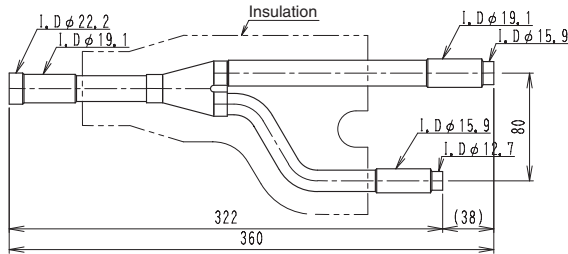

Liquid Side

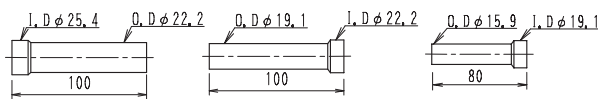
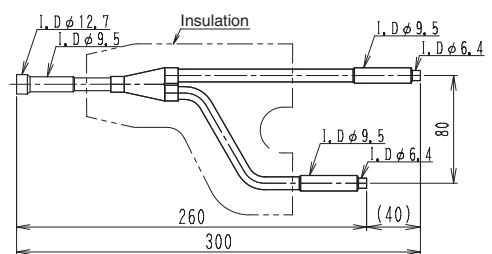

C : D3K05235B

KHRP26A72T

Gas Side

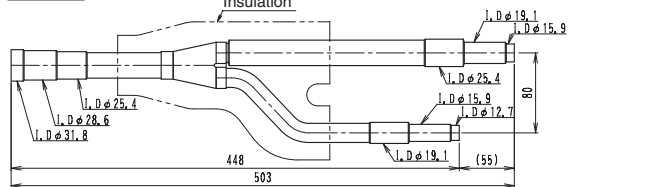

Liquid Side

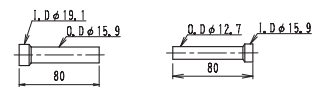
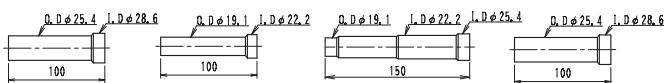
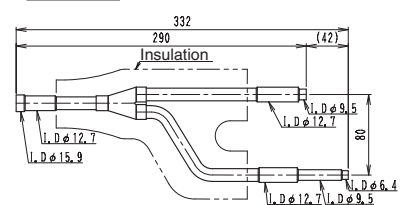

C : D3K05236A

KHRP26A73T

Gas Side

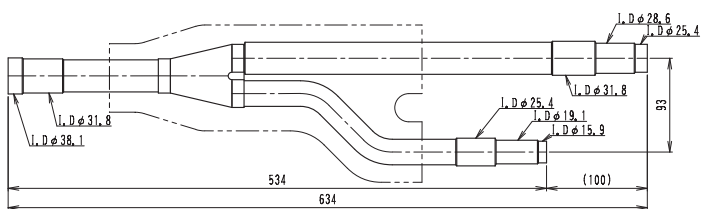

Liquid Side

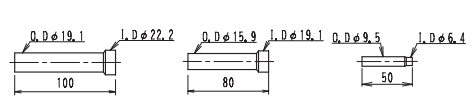
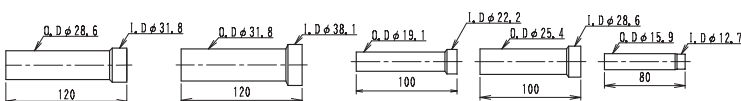
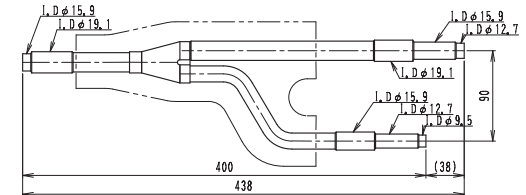

C : D3K05237A

7.10.2 REFNET Header (Branch Kit)

KHRP26M22H

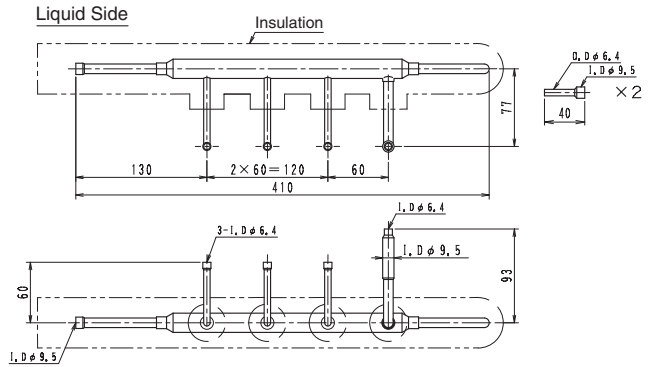
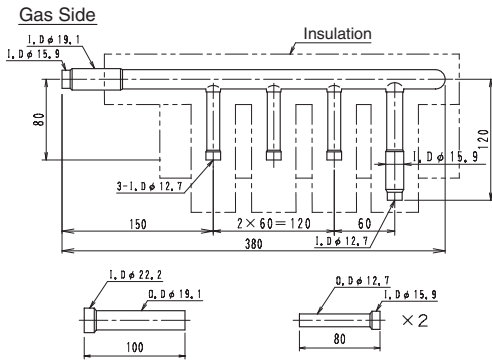

D3K03629C

KHRP26M33H

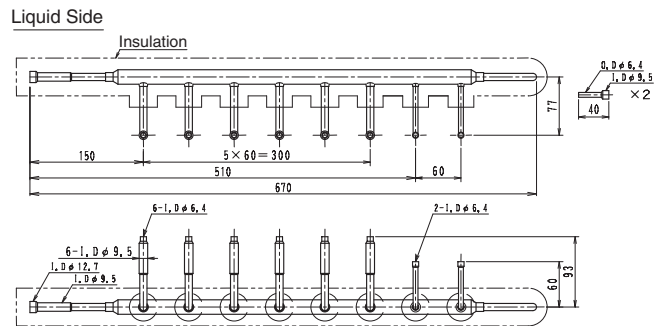
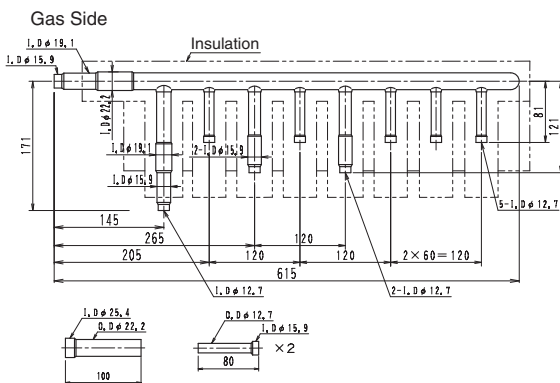

D3K03630C

KHRP26M72H

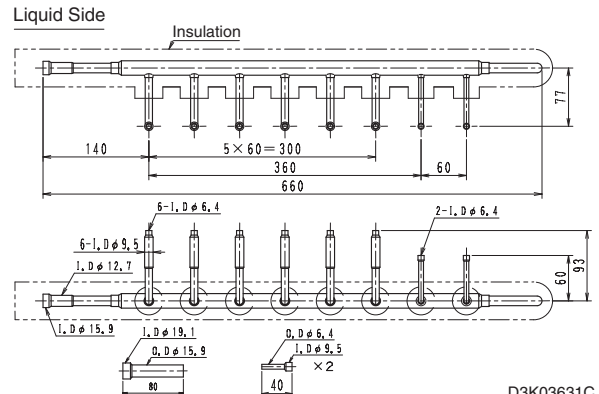
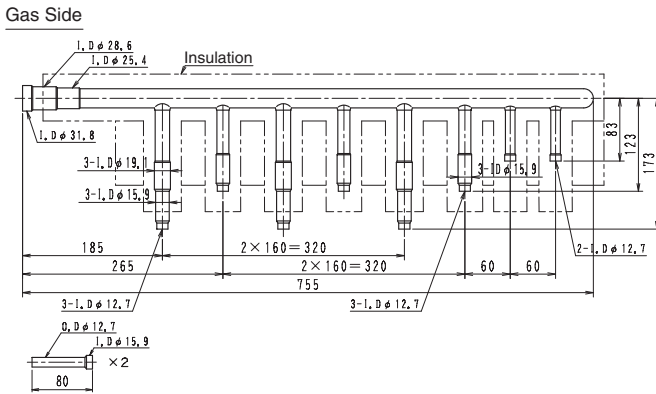

D3K03631C

KHRP26M73H

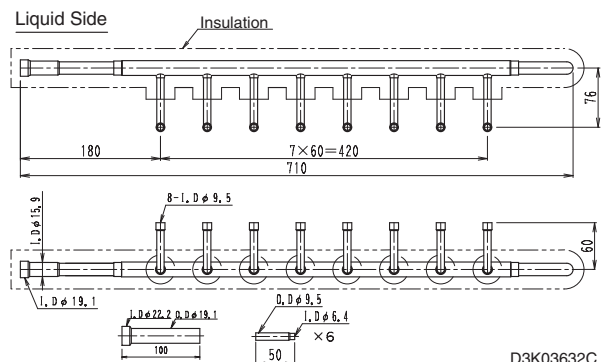
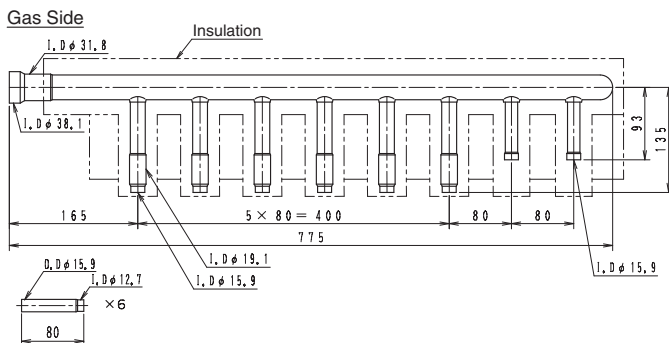

D3K03632C

7.10.3 Reducer

7.10.4.1 Pipe size reducer (For R-410A)

KHRP26M73TP • 73HP

KHRP25M72TP • 73TP • 72HP

- This includes the following parts.

	pipe size reducer ①	pipe size reducer ②	pipe size reducer ③	pipe size reducer ④	pipe size reducer ⑤	
SHAPE						
Quantity	KHRP26M73TP	1pc.	1pc.	2pc.	—	
	KHRP26M73HP	1pc.	—	1pc.	—	
	KHRP25M72TP	—	—	—	1pc.	1pc.
	KHRP25M72HP	—	—	—	—	1pc.
	KHRP25M73TP	1pc.	1pc.	3pc.	1pc.	—

- This kit is the reducer of the branch piping kit (refnet joint • header).
Check the proper model of the branch piping kit.

Kit name	Branch piping kit
KHRP26M73TP	KHRP26M73T (gas side)
KHRP26M73HP	KHRP26M73H (gas side) • KHRP25M73H (suction gas side)
KHRP25M72TP	KHRP25M72T (discharge gas side)
KHRP25M72HP	KHRP25M72T (discharge gas side)
KHRP25M73TP	KHRP25M73T (suction, discharge side)

Installation procedure

Refer to the installation manual of the branch piping kit.

- Joint size are as follows

<p>pipe size reducer ①</p>	<p>pipe size reducer ②</p>	<p>pipe size reducer ③</p>
<p>pipe size reducer ④</p>	<p>pipe size reducer ⑤</p>	

- (1) Select the field piping size according to the installation manual of the outdoor unit.
- (2) Connect the PIPE SIZE REDUCER suitable for the field piping size to the branch piping kit.
ex.) Connect the reducers to the branch piping kit. KHRP26M73T.
• For inlet piping size is Ø 41.3 and outlet 1 piping size is Ø 34.9

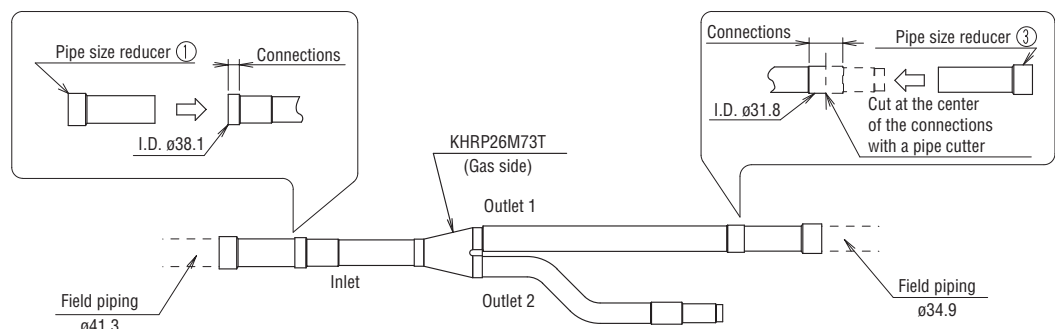

3P113129A

7.10.4 REFNET Joints and Headers

7.10.4.1 REFNET Joints

For gas and liquid branch pipes

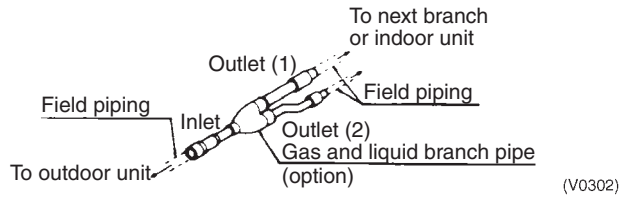

- Make sure that all branch pipes are fitted such that they branch either horizontally or vertically.

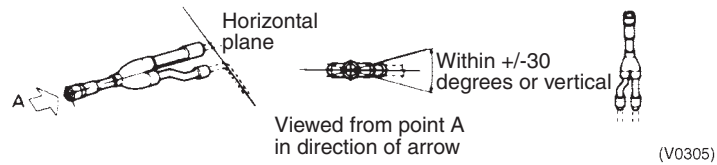

- When the size of the selected field piping is different from that of branch pipe then the connecting section should be cut with a pipe cutter as shown in the figure below.

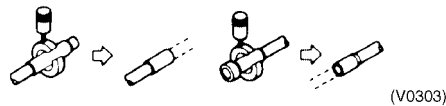

- When you are cutting an inlet or outlet pipe with a pipe cutter make sure that you make the cut in the center of the connection area.

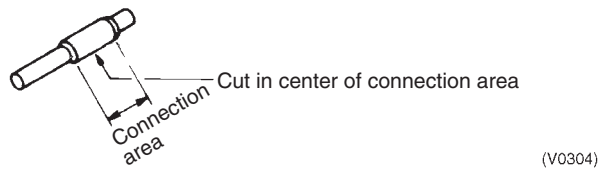

- Branch pipes must be insulated in accordance with the handbook which comes with each kit.

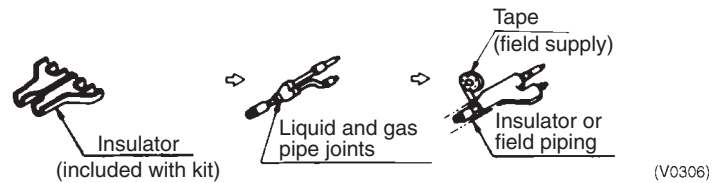

7.10.4.2 REFNET Header

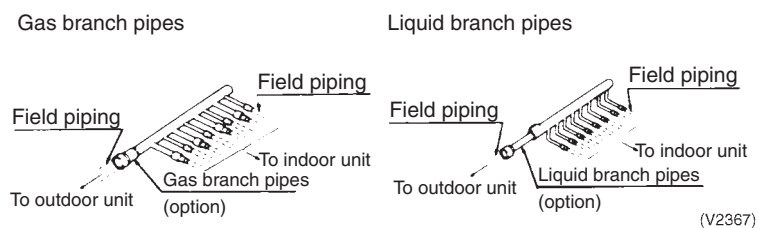

- When the number of indoor units to be connected to the branch pipes is less than the number of branch pipes available for connection then cap pipes should be fitted to the surplus branches.

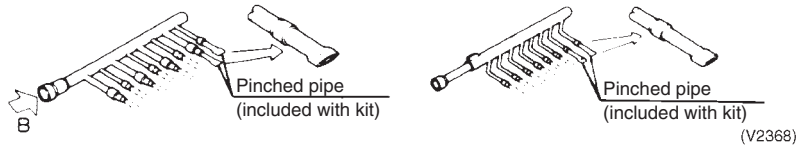

- When the size of the selected field piping is different from that of branch pipe then the connecting section should be cut with a pipe cutter as shown in the figure below.

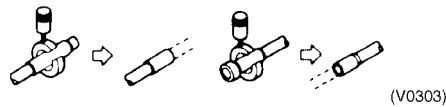

- When field piping is connected to the B section of the inlet/outlet pipe on the outdoor unit side of the liquid pipe header.
- Cut the B section with a pipe cutter as shown below and connect it to the A section.
- Connect the flared section of the field pipe to the B section.

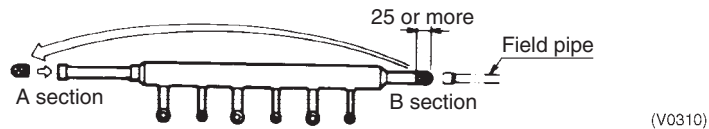

- Fit the branch pipe so that the branch lies in a horizontal plane.

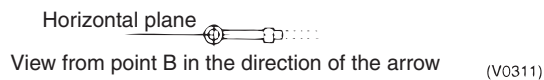

- The branch pipe must be insulated in accordance with the instruction manual which comes with each kit.

1. Use the insulator included in the kit to insulate the header.

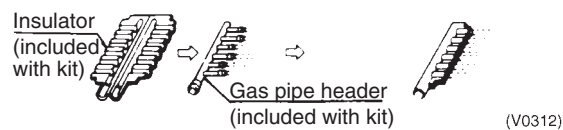

2. Joints between insulators included in the kit and those already applied to the field piping should be sealed with the tape which is also included in each kit.

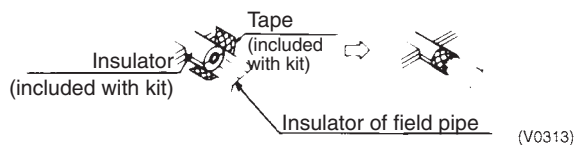

3. Any cap pipes should also be insulated using the insulator provided with each kit and then taped as described above.

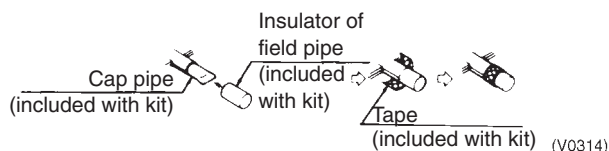

7.11 VRV Inspection Sheet

Inspection date: _____

Delivery date: _____

Transfer date: _____

Owner		System name	
-------	--	-------------	--

Outdoor units

	Installation location	Model	Unit No.
Outdoor unit system name			
Outdoor unit 1			
Outdoor unit 2			
Outdoor unit 3			

Indoor units

No.	Installation location	Model	Unit No.	Group No.	No.	Installation location	Model	Unit No.	Group No.
1					21				
2					22				
3					23				
4					24				
5					25				
6					26				
7					27				
8					28				
9					29				
10					30				
11					31				
12					32				
13					33				
14					34				
15					35				
16					36				
17					37				
18					38				
19					39				
20					40				

Field settings

C/H SELECT (setting mode 1)			C/H SELECT setting (DS1-1)			Low noise operation			Sequential start	
IND	MASTER	SLAVE	ON	OFF		ON	OFF		ON	OFF
Tc			Te			Defrost SETTING			Refrigerant addition/replenishment	
H	M	L	H	M	L	H	M	L	kg	

Company name _____

Inspector _____

(V1091)

Before turning on the power

System name _____

	Inspection item	Inspection method	Standard (guideline)	Measurement values				Decision				
	Breaker capacity	Visual inspection	Specified capacity	G NG								
Outdoor unit 1	Refrigerant piping system	Gas detector	No leaks	G NG								
	Heat exchanger	Visual inspection	No clogging or damage	G NG								
	Terminal connection section	Screwdriver, etc.	No looseness	G NG								
	Fan motor electrical insulation	500-V megatester	1 MΩ or more	MΩ								
	Compressor electrical insulation	500-V megatester	1 MΩ or more	INV	MΩ	STD1	MΩ	STD2	MΩ			
	Installation	Visual inspection	Short circuit, etc.	G NG								
Outdoor unit 2	Refrigerant piping system	Gas detector	No leaks	G NG								
	Heat exchanger	Visual inspection	No clogging or damage	G NG								
	Terminal connection section	Screwdriver, etc.	No looseness	G NG								
	Fan motor electrical insulation	500-V megatester	1 MΩ or more	MΩ								
	Compressor electrical insulation	500-V megatester	1 MΩ or more									
	Installation	Visual inspection	Short circuit, etc.	G NG								
Outdoor unit 3	Refrigerant piping system	Gas detector	No leaks	G NG								
	Heat exchanger	Visual inspection	No clogging or damage	G NG								
	Terminal connection section	Screwdriver, etc.	No looseness	G NG								
	Fan motor electrical insulation	500-V megatester	1 MΩ or more	MΩ								
	Compressor electrical insulation	500-V megatester	1 MΩ or more									
	Installation	Visual inspection	Short circuit, etc.	G NG								
Indoor unit	Refrigerant system	Gas detector	No leaks	Room 1	G NG	Room 2	G NG	Room 3	G NG	Room 4	G NG	
				Room 5	G NG	Room 6	G NG	Room 7	G NG	Room 8	G NG	
				Room 9	G NG	Room 10	G NG	Room 11	G NG	Room 12	G NG	
				Room 13	G NG	Room 14	G NG	Room 15	G NG	Room 16	G NG	
				Room 17	G NG	Room 18	G NG	Room 19	G NG	Room 20	G NG	
				Room 21	G NG	Room 22	G NG	Room 23	G NG	Room 24	G NG	
				Room 25	G NG	Room 26	G NG	Room 27	G NG	Room 28	G NG	
				Room 29	G NG	Room 30	G NG	Room 31	G NG	Room 32	G NG	
				Room 33	G NG	Room 34	G NG	Room 35	G NG	Room 36	G NG	
				Room 37	G NG	Room 38	G NG	Room 39	G NG	Room 40	G NG	
	Air filter	Visual inspection	No clogging or damage	Room 1	G NG	Room 2	G NG	Room 3	G NG	Room 4	G NG	
				Room 5	G NG	Room 6	G NG	Room 7	G NG	Room 8	G NG	
				Room 9	G NG	Room 10	G NG	Room 11	G NG	Room 12	G NG	
				Room 13	G NG	Room 14	G NG	Room 15	G NG	Room 16	G NG	
				Room 17	G NG	Room 18	G NG	Room 19	G NG	Room 20	G NG	
				Room 21	G NG	Room 22	G NG	Room 23	G NG	Room 24	G NG	
				Room 25	G NG	Room 26	G NG	Room 27	G NG	Room 28	G NG	
				Room 29	G NG	Room 30	G NG	Room 31	G NG	Room 32	G NG	
				Room 33	G NG	Room 34	G NG	Room 35	G NG	Room 36	G NG	
				Room 37	G NG	Room 38	G NG	Room 39	G NG	Room 40	G NG	
	Heat exchanger	Visual inspection	No clogging or damage	Room 1	G NG	Room 2	G NG	Room 3	G NG	Room 4	G NG	
				Room 5	G NG	Room 6	G NG	Room 7	G NG	Room 8	G NG	
				Room 9	G NG	Room 10	G NG	Room 11	G NG	Room 12	G NG	
				Room 13	G NG	Room 14	G NG	Room 15	G NG	Room 16	G NG	
				Room 17	G NG	Room 18	G NG	Room 19	G NG	Room 20	G NG	
				Room 21	G NG	Room 22	G NG	Room 23	G NG	Room 24	G NG	
				Room 25	G NG	Room 26	G NG	Room 27	G NG	Room 28	G NG	
Room 29				G NG	Room 30	G NG	Room 31	G NG	Room 32	G NG		
Room 33				G NG	Room 34	G NG	Room 35	G NG	Room 36	G NG		
Room 37				G NG	Room 38	G NG	Room 39	G NG	Room 40	G NG		

	Inspection item	Inspection method	Standard (guideline)	Measurement values				Decision
				Room 1 G NG	Room 2 G NG	Room 3 G NG	Room 4 G NG	
Indoor unit	Fan motor electrical insulation	500-V megatester	1 MΩ or more	Room 5 G NG	Room 6 G NG	Room 7 G NG	Room 8 G NG	
				Room 9 G NG	Room 10 G NG	Room 11 G NG	Room 12 G NG	
				Room 13 G NG	Room 14 G NG	Room 15 G NG	Room 16 G NG	
				Room 17 G NG	Room 18 G NG	Room 19 G NG	Room 20 G NG	
				Room 21 G NG	Room 22 G NG	Room 23 G NG	Room 24 G NG	
				Room 25 G NG	Room 26 G NG	Room 27 G NG	Room 28 G NG	
				Room 29 G NG	Room 30 G NG	Room 31 G NG	Room 32 G NG	
				Room 33 G NG	Room 34 G NG	Room 35 G NG	Room 36 G NG	
				Room 37 G NG	Room 38 G NG	Room 39 G NG	Room 40 G NG	
	Auxiliary heater electrical insulation	500-V megatester	1 MΩ or more	Room 1 G NG	Room 2 G NG	Room 3 G NG	Room 4 G NG	
				Room 5 G NG	Room 6 G NG	Room 7 G NG	Room 8 G NG	
				Room 9 G NG	Room 10 G NG	Room 11 G NG	Room 12 G NG	
				Room 13 G NG	Room 14 G NG	Room 15 G NG	Room 16 G NG	
				Room 17 G NG	Room 18 G NG	Room 19 G NG	Room 20 G NG	
				Room 21 G NG	Room 22 G NG	Room 23 G NG	Room 24 G NG	
				Room 25 G NG	Room 26 G NG	Room 27 G NG	Room 28 G NG	
				Room 29 G NG	Room 30 G NG	Room 31 G NG	Room 32 G NG	
				Room 33 G NG	Room 34 G NG	Room 35 G NG	Room 36 G NG	
	Installation	Visual inspection	Short circuit, etc.	Room 1 G NG	Room 2 G NG	Room 3 G NG	Room 4 G NG	
				Room 5 G NG	Room 6 G NG	Room 7 G NG	Room 8 G NG	
				Room 9 G NG	Room 10 G NG	Room 11 G NG	Room 12 G NG	
				Room 13 G NG	Room 14 G NG	Room 15 G NG	Room 16 G NG	
				Room 17 G NG	Room 18 G NG	Room 19 G NG	Room 20 G NG	
				Room 21 G NG	Room 22 G NG	Room 23 G NG	Room 24 G NG	
				Room 25 G NG	Room 26 G NG	Room 27 G NG	Room 28 G NG	
				Room 29 G NG	Room 30 G NG	Room 31 G NG	Room 32 G NG	
				Room 33 G NG	Room 34 G NG	Room 35 G NG	Room 36 G NG	

(V1092)

During operation

System name _____

	Inspection item	Inspection method	Standard (guideline)	Measurement values				Decision		
Outdoor unit 1	Main power supply voltage	Tester	Rated voltage ±10%	R-S	V	S-T	V	R-T	V	
	Operation circuit voltage	Tester	Rated voltage ±10%					V		
	Fan rotation direction	Visual inspection	Forward rotation	G NG						
	Fan noise/vibration	Listening	No noise or vibration							
	Fan operation current	Clamp meter		RED WHITE BLACK A A A						
	Suction air temperature	Thermometer	Temperature differential 9~11deg. when cooling, 2~3.5deg. when heating					°C		
	Discharge air temperature	Thermometer						°C		
	Compressor discharge pressure	Pressure gauge						MPa		
	Compressor suction pressure	Pressure gauge						MPa		
	Compressor operating current	Clamp meter	Phase differential within 1A	INV	U()A,	V()A,	W()A			
				STD1	R()A,	S()A,	T()A			
				STD2	R()A,	S()A,	T()A			
	Compressor operating frequency	Clamp meter		INV					Hz	
Suction pipe temperature	Thermometer	3~15°C	INV	°C	STD1	°C	STD2	°C		
Discharge pipe temperature	Thermometer	85~105°C	INV	°C	STD1	°C	STD2	°C		
Clank case heater	Touch	Warm	INV	G-NG	STD1	G-NG	STD2	G-NG		
Outdoor unit 2	Main power supply voltage	Tester	Rated voltage ±10%	R-S	V	R-S	V	R-S	V	
	Operation circuit voltage	Tester	Rated voltage ±10%					V		
	Fan rotation direction	Visual inspection	Forward rotation	G NG						
	Fan noise/vibration	Listening	No noise or vibration							
	Fan operation current	Clamp meter		RED WHITE BLACK A A A						
	Suction air temperature	Thermometer	Temperature differential 9~11deg. when cooling, 2~3.5deg. when heating					°C		
	Discharge air temperature	Thermometer						°C		
	Compressor discharge pressure	Pressure gauge						MPa		
	Compressor suction pressure	Pressure gauge						MPa		
	Compressor operating current	Clamp meter	Phase differential within 1A	INV	U()A,	V()A,	W()A			
				STD1	R()A,	S()A,	T()A			
				STD2	R()A,	S()A,	T()A			
	Compressor operating frequency	Clamp meter		INV					Hz	
Suction pipe temperature	Thermometer	3~15°C	INV	°C	STD1	°C	STD2	°C		
Discharge pipe temperature	Thermometer	85~105°C	INV	°C	STD1	°C	STD2	°C		
Clank case heater	Touch	Warm	INV	G-NG	STD1	G-NG	STD2	G-NG		
Outdoor unit 3	Main power supply voltage	Tester	Rated voltage ±10%	R-S	V	R-S	V	R-S	V	
	Operation circuit voltage	Tester	Rated voltage ±10%					V		
	Fan rotation direction	Visual inspection	Forward rotation	G NG						
	Fan noise/vibration	Listening	No noise or vibration							
	Fan operation current	Clamp meter		RED WHITE BLACK A A A						
	Suction air temperature	Thermometer	Temperature differential 9~11deg. when cooling, 2~3.5deg. when heating					°C		
	Discharge air temperature	Thermometer						°C		
	Compressor discharge pressure	Pressure gauge						MPa		
	Compressor suction pressure	Pressure gauge						MPa		
	Compressor operating current	Clamp meter	Phase differential within 1A	INV	U()A,	V()A,	W()A			
				STD1	R()A,	S()A,	T()A			
				STD2	R()A,	S()A,	T()A			
	Compressor operating frequency	Clamp meter		INV					Hz	
Suction pipe temperature	Thermometer	3~15°C	INV	°C	STD1	°C	STD2	°C		
Discharge pipe temperature	Thermometer	85~105°C	INV	°C	STD1	°C	STD2	°C		
Clank case heater	Touch	Warm	NV	G-NG	STD1	G-NG	STD2	G-NG		

(V1093)

During operation

System name

	Inspection item	Inspection method	Standard (guideline)	Measurement values				Decision				
				Room 1	Room 2	Room 3	Room 4					
Indoor unit	Powerly supply voltage	Tester	Rated voltage ±10%	Room 1	V	Room 2	V	Room 3	V	Room 4	V	
				Room 5	V	Room 6	V	Room 7	V	Room 8	V	
				Room 9	V	Room10	V	Room11	V	Room12	V	
				Room13	V	Room14	V	Room15	V	Room16	V	
				Room17	V	Room18	V	Room19	V	Room20	V	
				Room21	V	Room22	V	Room23	V	Room24	V	
				Room25	V	Room26	V	Room27	V	Room28	V	
				Room29	V	Room30	V	Room31	V	Room32	V	
	Suction air temperature	Thermometer	Thermometer differential 9~13 °C when cooling, 15~20 °C when heating	Room 1	°C	Room 2	°C	Room 3	°C	Room 4	°C	
				Room 5	°C	Room 6	°C	Room 7	°C	Room 8	°C	
				Room 9	°C	Room10	°C	Room11	°C	Room12	°C	
				Room13	°C	Room14	°C	Room15	°C	Room16	°C	
				Room17	°C	Room18	°C	Room19	°C	Room20	°C	
				Room21	°C	Room22	°C	Room23	°C	Room24	°C	
				Room25	°C	Room26	°C	Room27	°C	Room28	°C	
				Room29	°C	Room30	°C	Room31	°C	Room32	°C	
	Discharge air temperature	Thermometer	Thermometer differential 9~13 °C when cooling, 15~20 °C when heating	Room 1	°C	Room 2	°C	Room 3	°C	Room 4	°C	
				Room 5	°C	Room 6	°C	Room 7	°C	Room 8	°C	
				Room 9	°C	Room10	°C	Room11	°C	Room12	°C	
				Room13	°C	Room14	°C	Room15	°C	Room16	°C	
				Room17	°C	Room18	°C	Room19	°C	Room20	°C	
				Room21	°C	Room22	°C	Room23	°C	Room24	°C	
				Room25	°C	Room26	°C	Room27	°C	Room28	°C	
				Room29	°C	Room30	°C	Room31	°C	Room32	°C	
	Fan rotation direction	Visual inspection	Forward rotation	Room 1	G NG	Room 2	G NG	Room 3	G NG	Room 4	G NG	
				Room 5	G NG	Room 6	G NG	Room 7	G NG	Room 8	G NG	
				Room 9	G NG	Room 10	G NG	Room 11	G NG	Room 12	G NG	
				Room 13	G NG	Room 14	G NG	Room 15	G NG	Room 16	G NG	
				Room 17	G NG	Room 18	G NG	Room 19	G NG	Room 20	G NG	
				Room 21	G NG	Room 22	G NG	Room 23	G NG	Room 24	G NG	
				Room 25	G NG	Room 26	G NG	Room 27	G NG	Room 28	G NG	
				Room 29	G NG	Room 30	G NG	Room 31	G NG	Room 32	G NG	
	Fan noise/vibration	Listening	No noise or vibration	Room 1	G NG	Room 2	G NG	Room 3	G NG	Room 4	G NG	
				Room 5	G NG	Room 6	G NG	Room 7	G NG	Room 8	G NG	
				Room 9	G NG	Room 10	G NG	Room 11	G NG	Room 12	G NG	
				Room 13	G NG	Room 14	G NG	Room 15	G NG	Room 16	G NG	
				Room 17	G NG	Room 18	G NG	Room 19	G NG	Room 20	G NG	
				Room 21	G NG	Room 22	G NG	Room 23	G NG	Room 24	G NG	
				Room 25	G NG	Room 26	G NG	Room 27	G NG	Room 28	G NG	
				Room 29	G NG	Room 30	G NG	Room 31	G NG	Room 32	G NG	
Fan operating current	Clamp meter		Room 1	A	Room 2	A	Room 3	A	Room 4	A		
			Room 5	A	Room 6	A	Room 7	A	Room 8	A		
			Room 9	A	Room10	A	Room11	A	Room12	A		
			Room13	A	Room14	A	Room15	A	Room16	A		
			Room17	A	Room18	A	Room19	A	Room20	A		
			Room21	A	Room22	A	Room23	A	Room24	A		
			Room25	A	Room26	A	Room27	A	Room28	A		
			Room29	A	Room30	A	Room31	A	Room32	A		
Room33	A	Room34	A	Room35	A	Room36	A					
Room37	A	Room38	A	Room39	A	Room40	A					

(V1094)

7.12 Piping System Diagrams

7.12.1 Outdoor Unit

7.12.1.1 Heat Pump/Cooling Only 50Hz

RXYQ5PY1

RXQ5PY1

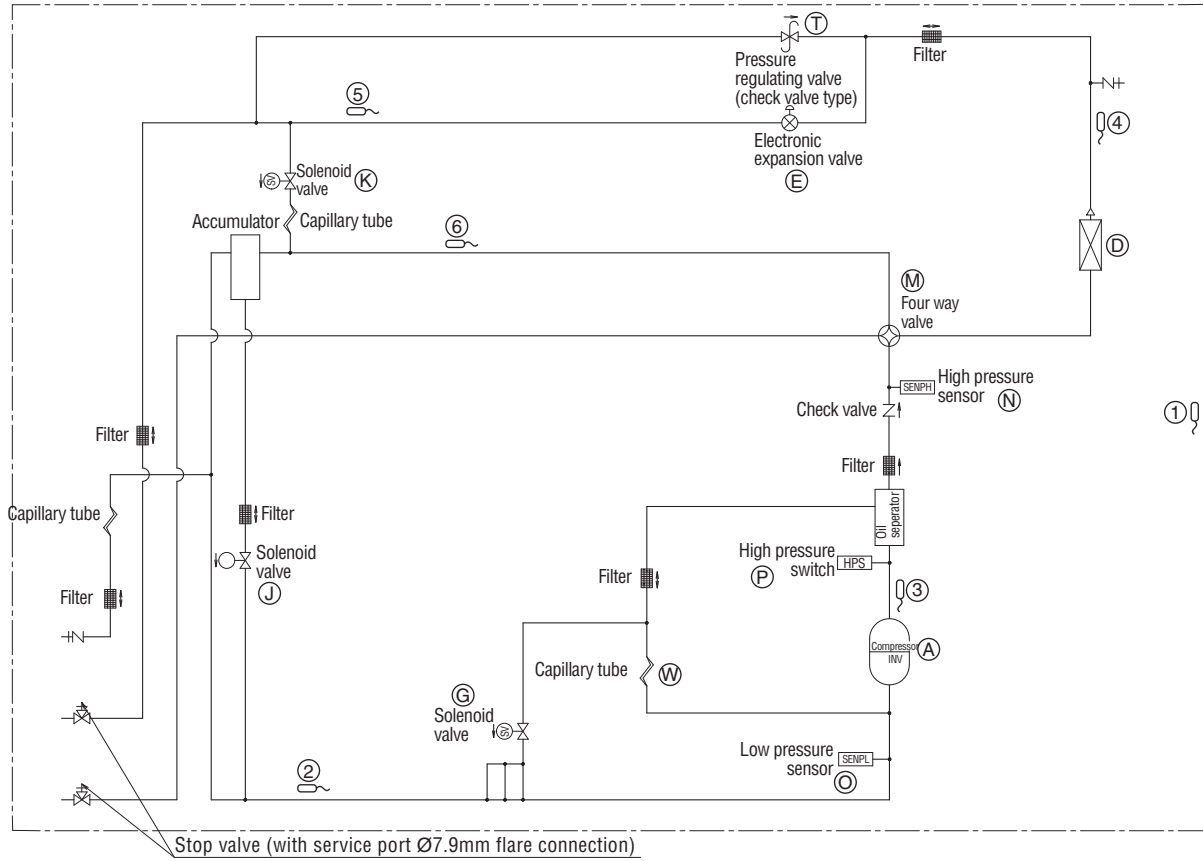

3D050782

RXYQ8PY1
RXQ8PY1

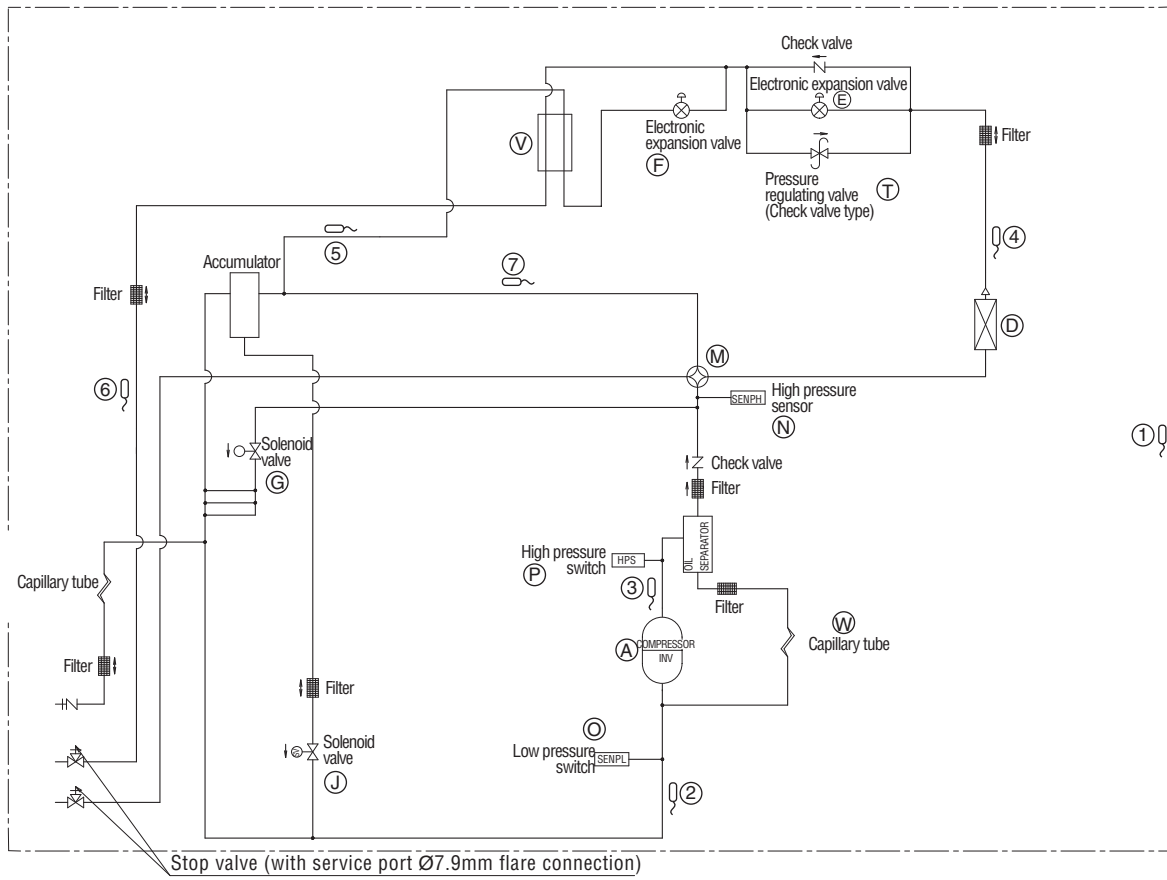

3D050783

RXYQ10PY1, RXYQ12PY1
 RXQ10PY1, RXQ12PY1

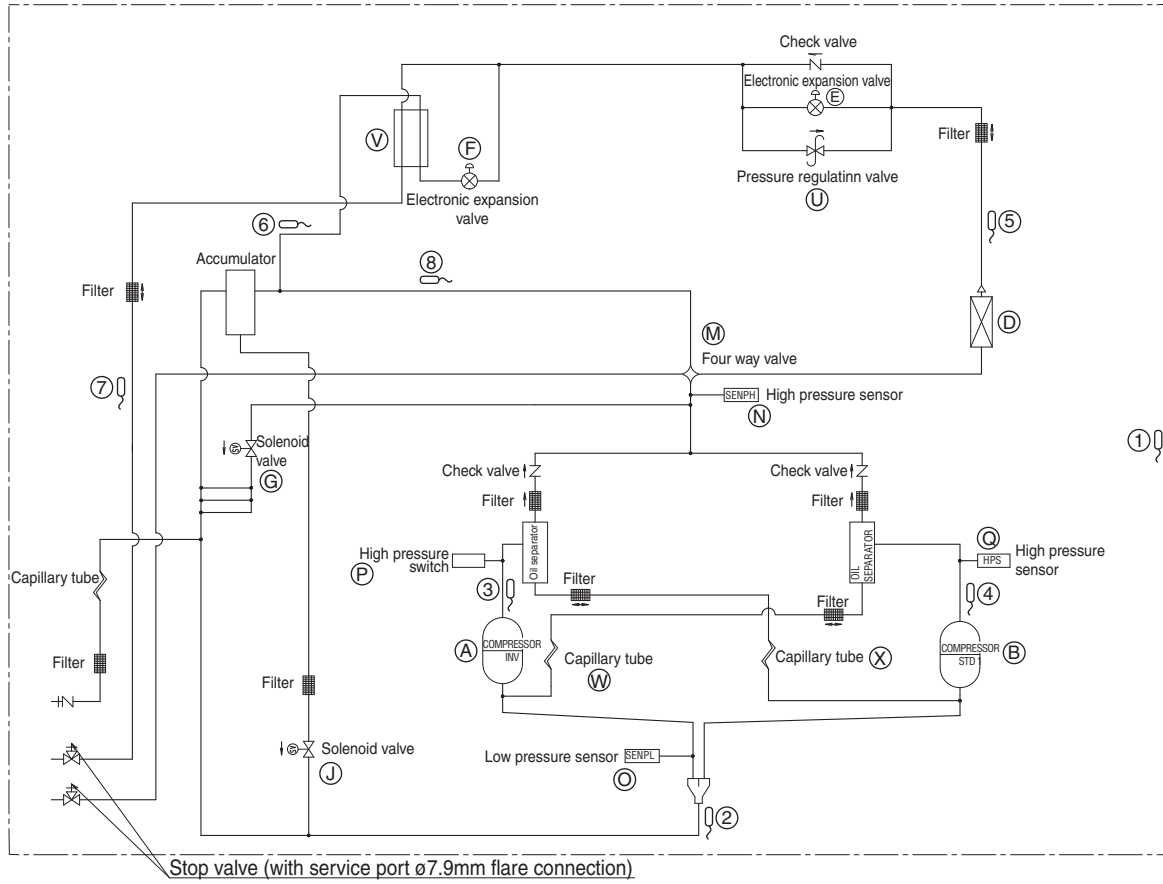

3D050784

**RXYQ14PY1, RXYQ16PY1, RXYQ18PY1
RXQ14PY1, RXQ16PY1, RXQ18PY1**

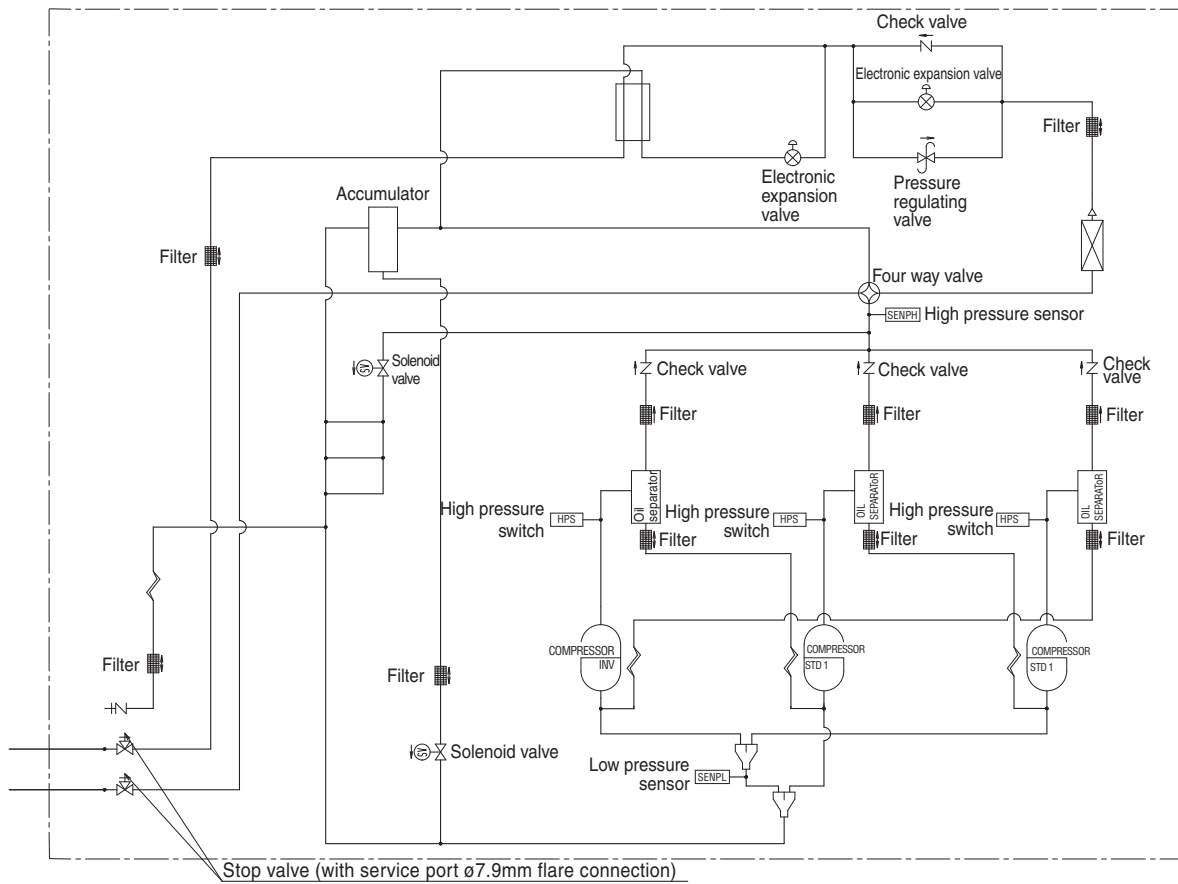

3D050785A

7.12.1.2 Heat Pump 60Hz

RXYQ5PYL

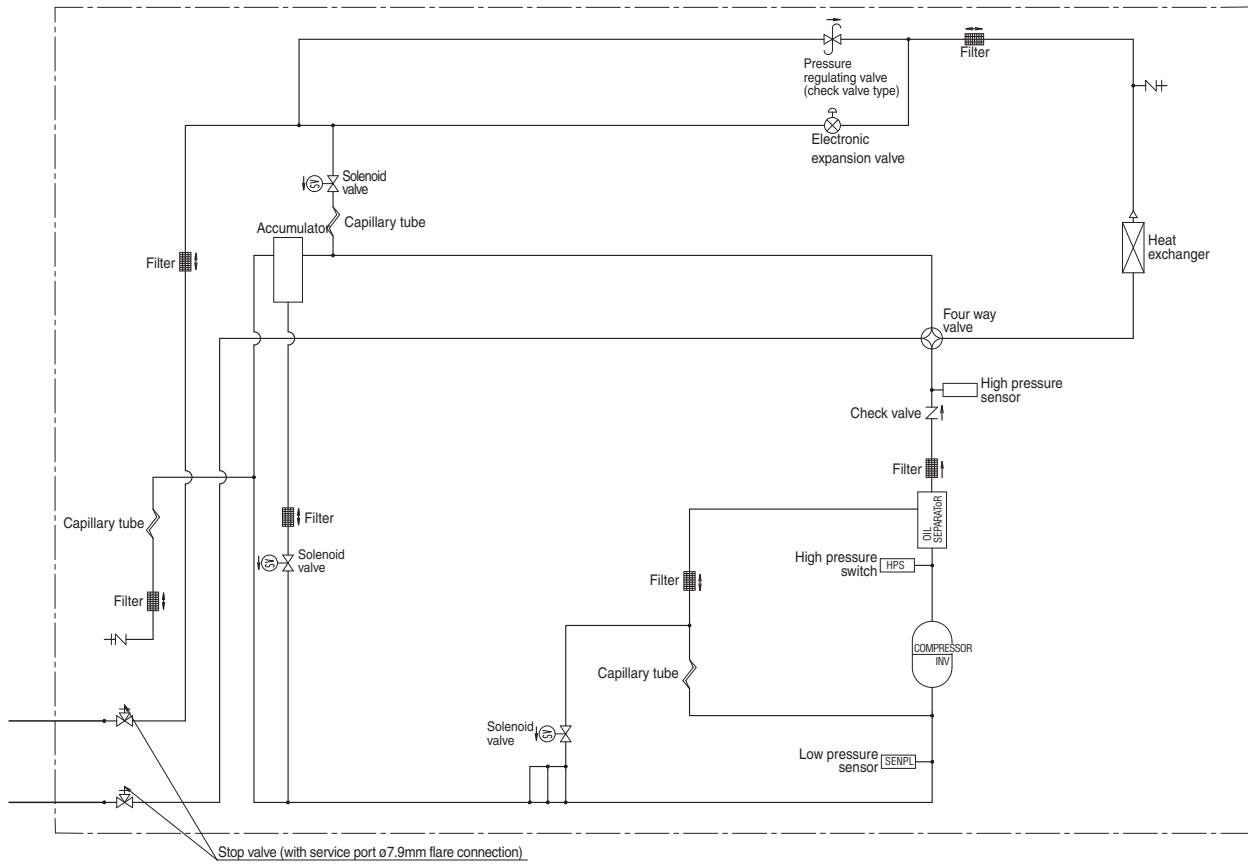

3D055764A

RXYQ8PYL

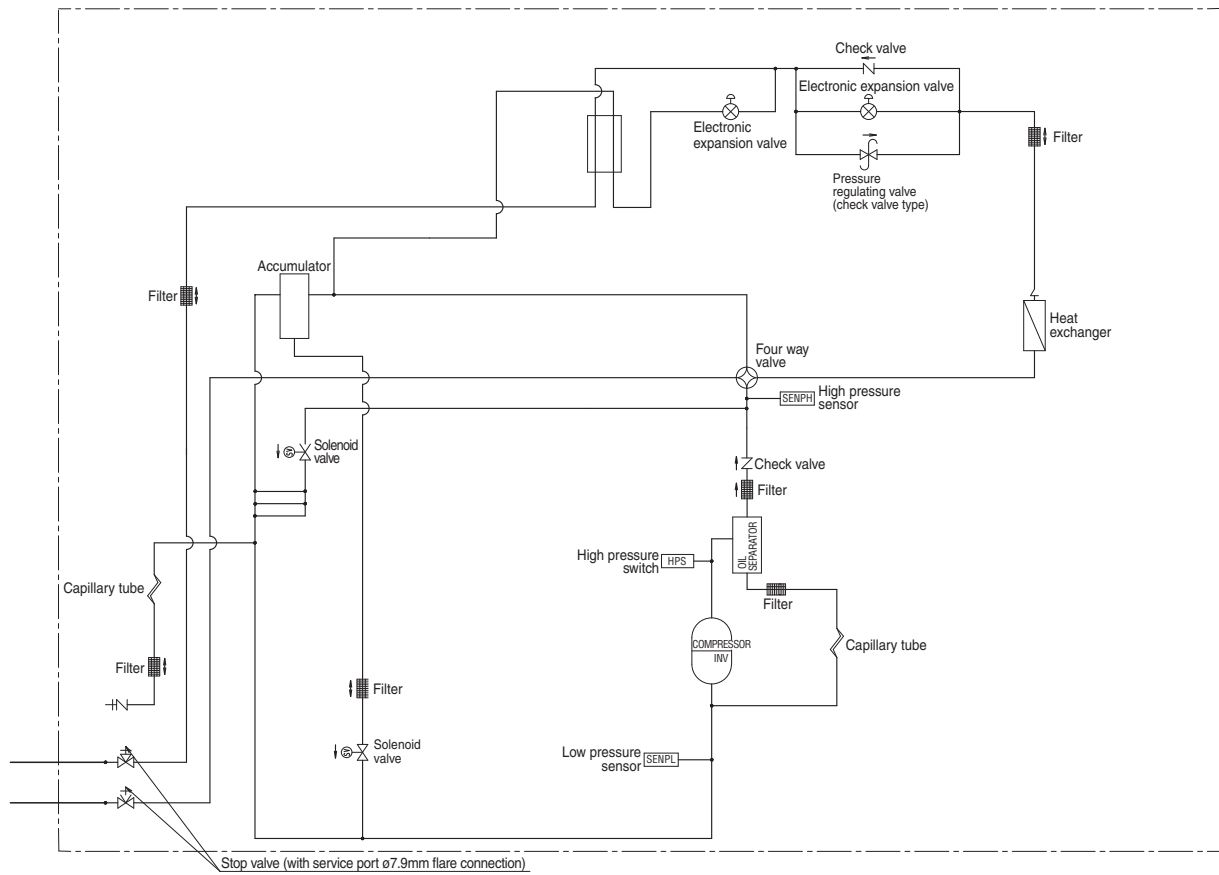

3D055765A

RXYQ10PYL, RXYQ12PYL

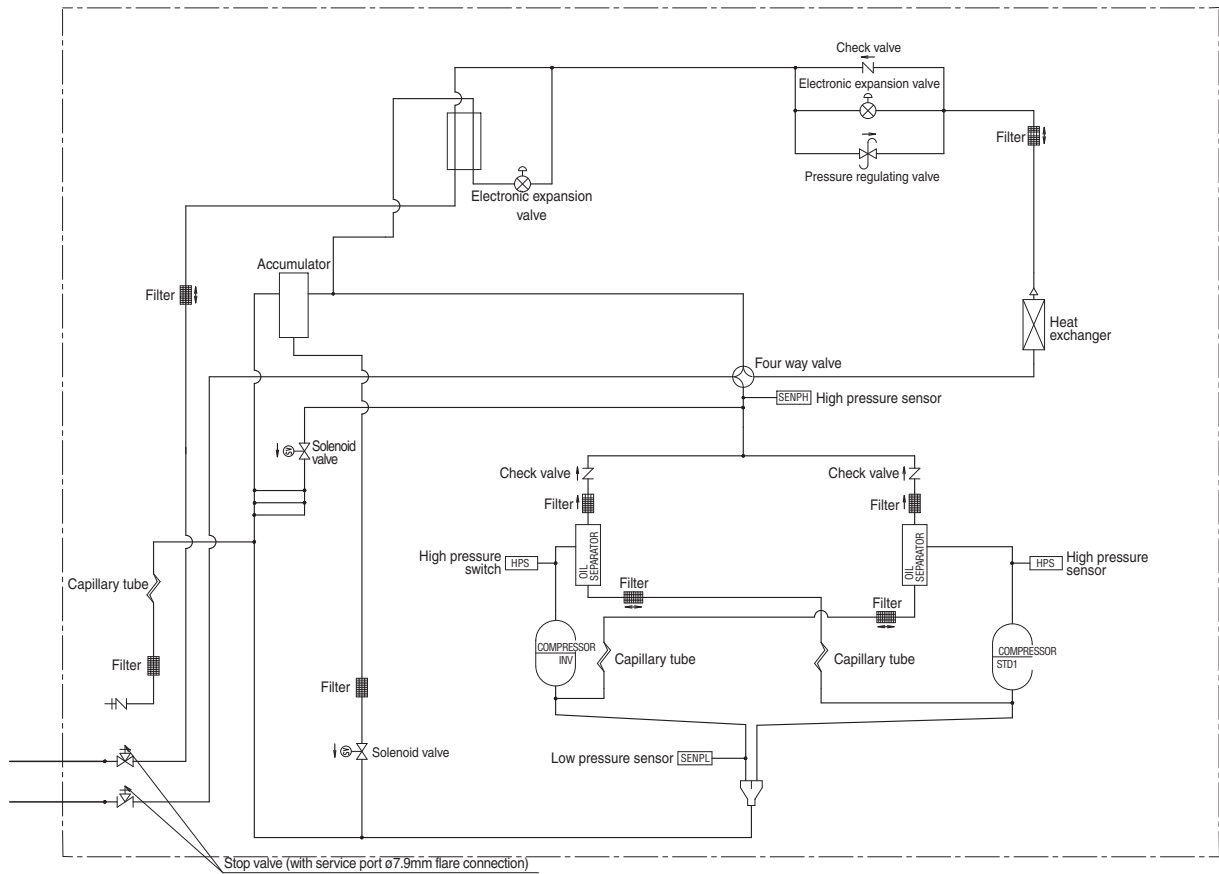

3D055766B

RXYQ14PYL, RXYQ16PYL, RXYQ18PYL

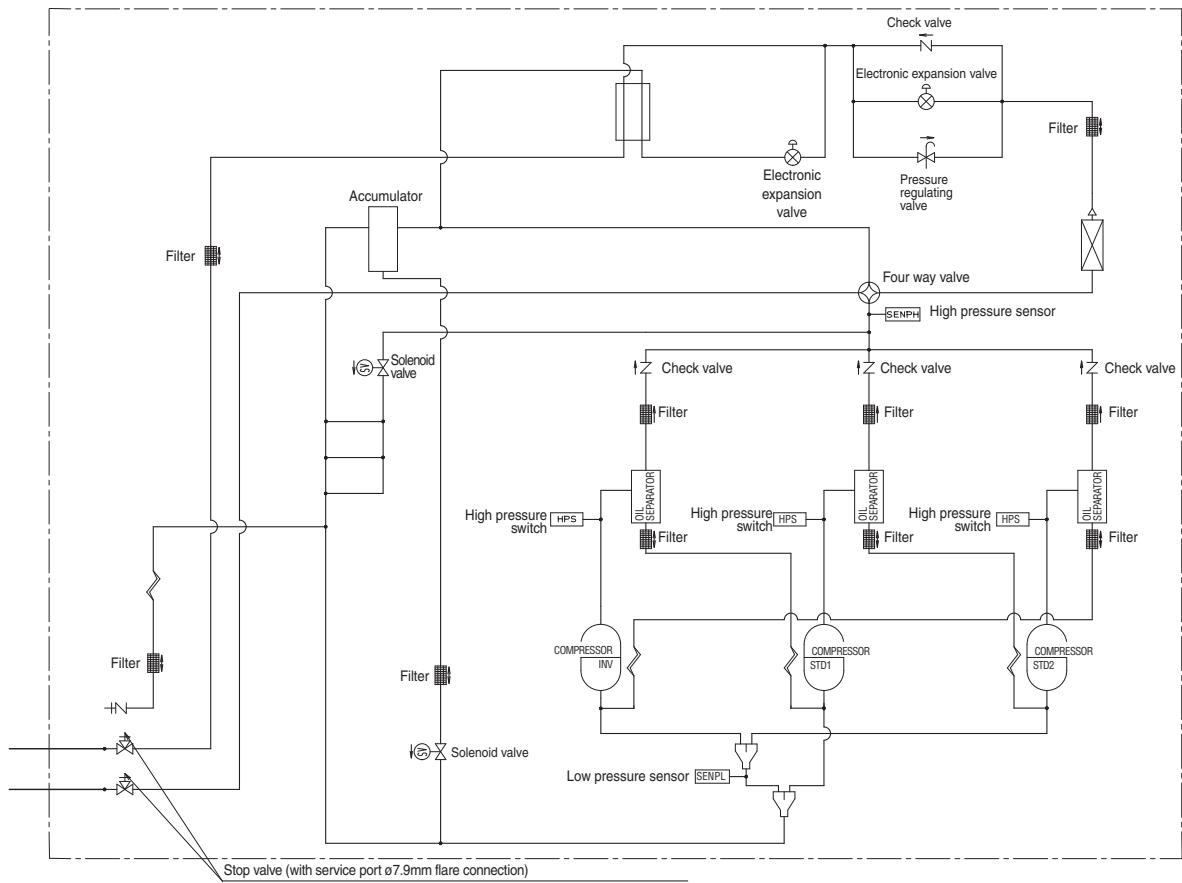

3D050785A

7.12.2 Indoor Unit

FXCQ, FXFQ, FXKQ, FXSQ, FXMQ, FXHQ, FXAQ, FXLQ, FXNQ

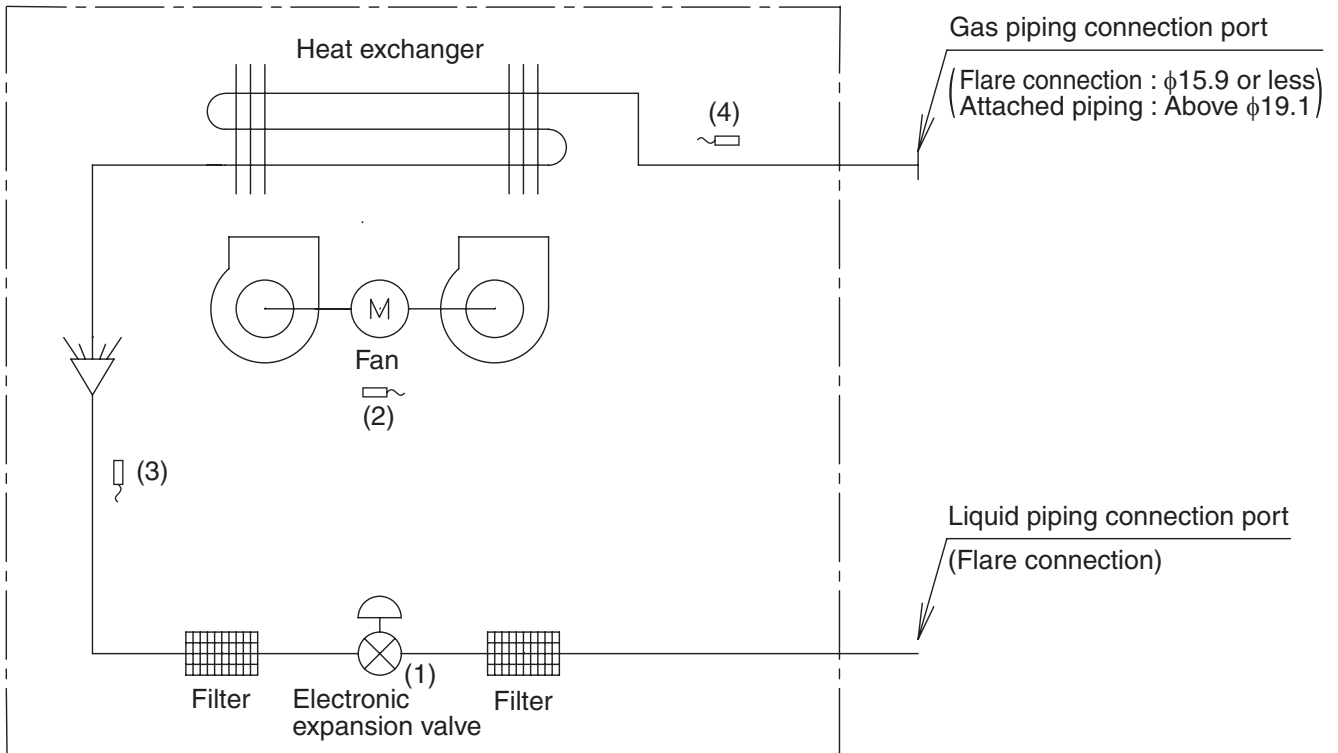

4D040157

Cod e	Name	Code	Main function	Cod e
(1)	Electronic expansion valve	Y1E	Used for gas superheated degree control while in cooling operation or subcooled degree control while in heating operation.	(1)
(2)	Suction air temperature thermistor	R1T	Used for thermostat control.	(2)
(3)	Liquid pipe	R2T	Used for gas superheated degree control while in cooling operation or subcooled degree control while in heating operation.	(3)
(4)	Gas pipe	R3T	Used for gas superheated degree control while in cooling operation.	(4)

(mm)

Capacity	GAS	Liquid
20 / 25 / 32 / 40 / 50M(A)	φ12.7	φ6.4
63 / 80 / 100 / 125M(A)	φ15.9	φ9.5
200M(A)	φ19.1	φ9.5
250M(A)	φ22.2	φ9.5

FXZQ

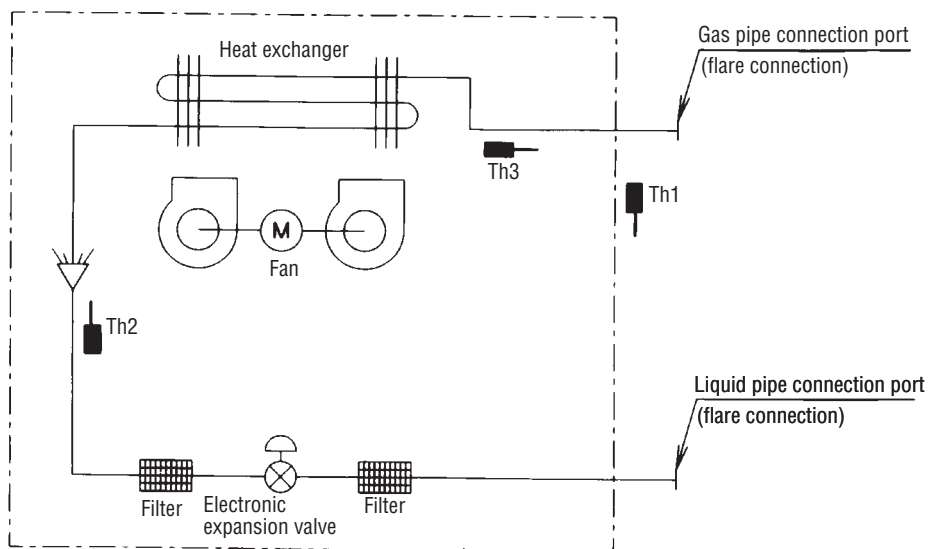

Th1: Thermistor for suction air temp.
 Th2: Thermistor for liquid air temp.
 Th3: Thermistor for gas line temp.

4D040157

■ Refrigerant pipe connection port diameters

(mm)

Model	Gas	Liquid
FXZQ20M / 25M / 32M / 40M / 50M	φ12.7	φ6.4

FXDQ

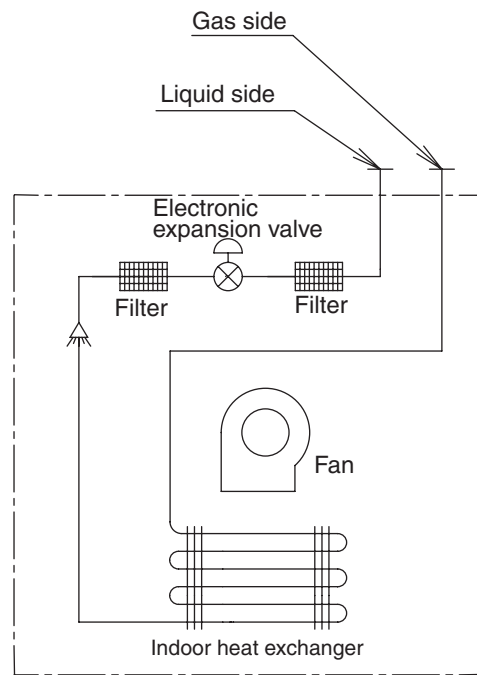

4D043864J

■ Refrigerant pipe connection port diameters

Model	(mm)	
	Gas	Liquid
FXDQ20N(A), P / 25N(A), P / 32N(A), P / 40N(A) / 50N(A)VE(T)	φ12.7	φ6.4
FXDQ63N(A)VE(T)	φ15.9	φ9.5

FXMQ125MF / 200MF / 250MFV1

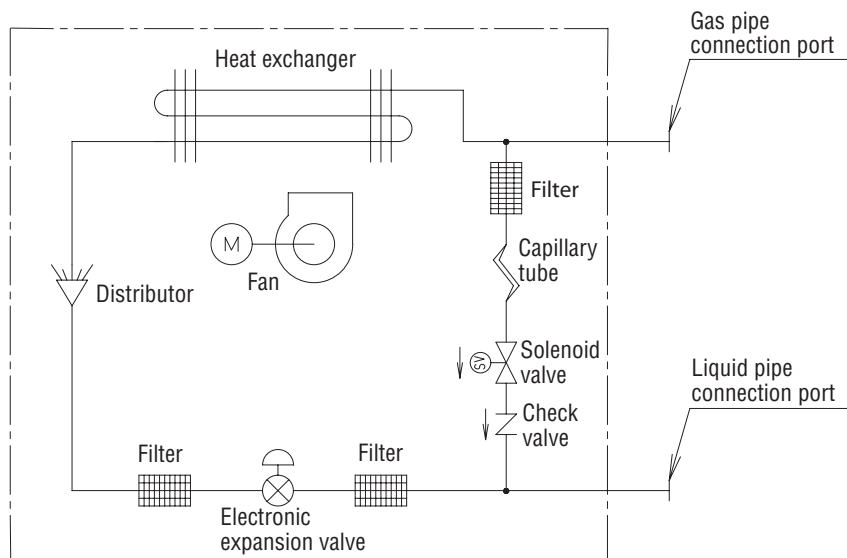

4D018650B

■ Refrigerant pipe connection port diameters

Model	(mm)	
	Gas	Liquid
FXMQ125MFV1	φ15.9	φ9.5
FXMQ200MFV1	φ19.1	φ9.5
FXMQ250MFV1	φ22.2	φ9.5

FXUQ + BEVQ

Indoor unit

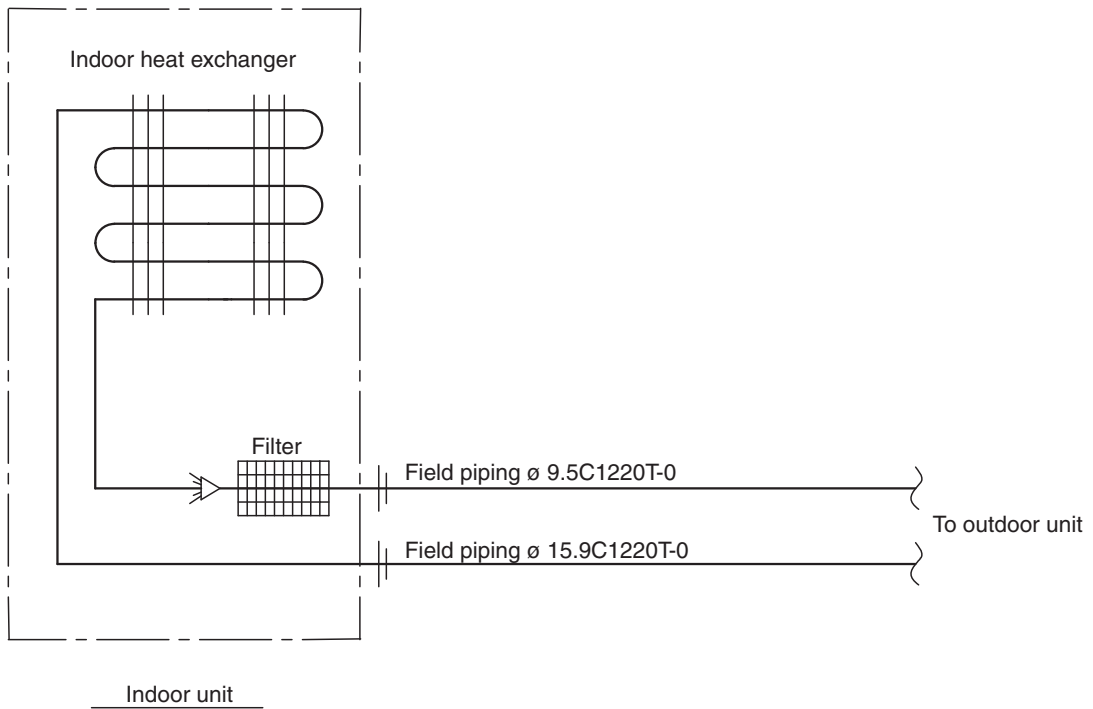

4D037995G

Connection Unit

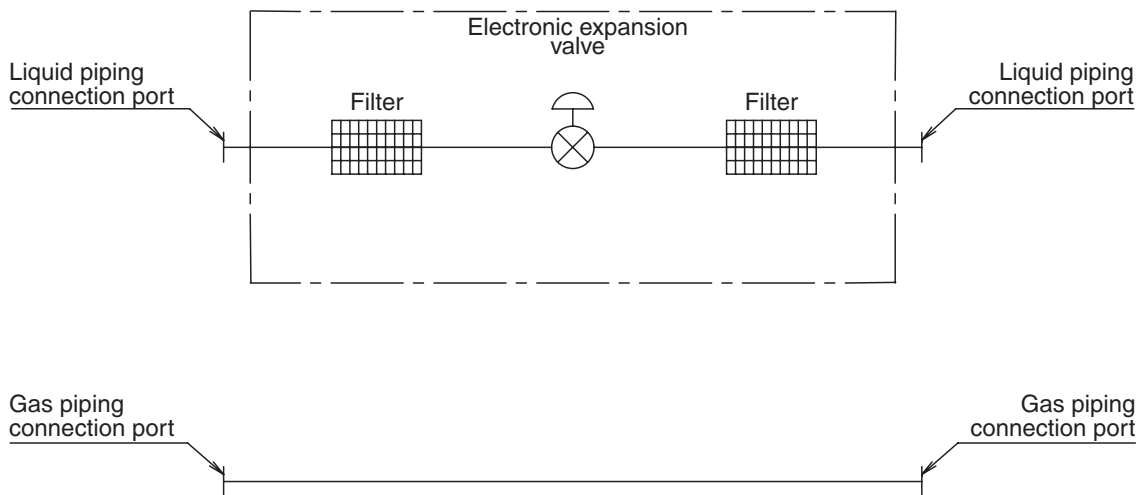

4D034127B

7.13 Wiring Diagrams (Heat Pump 50Hz/60Hz, Cooling Only 50Hz)

7.13.1 Heat Pump 50Hz/60Hz Outdoor Unit

RXYQ5PY1, RXYQ5PYL

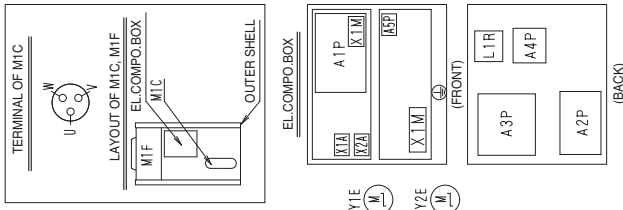
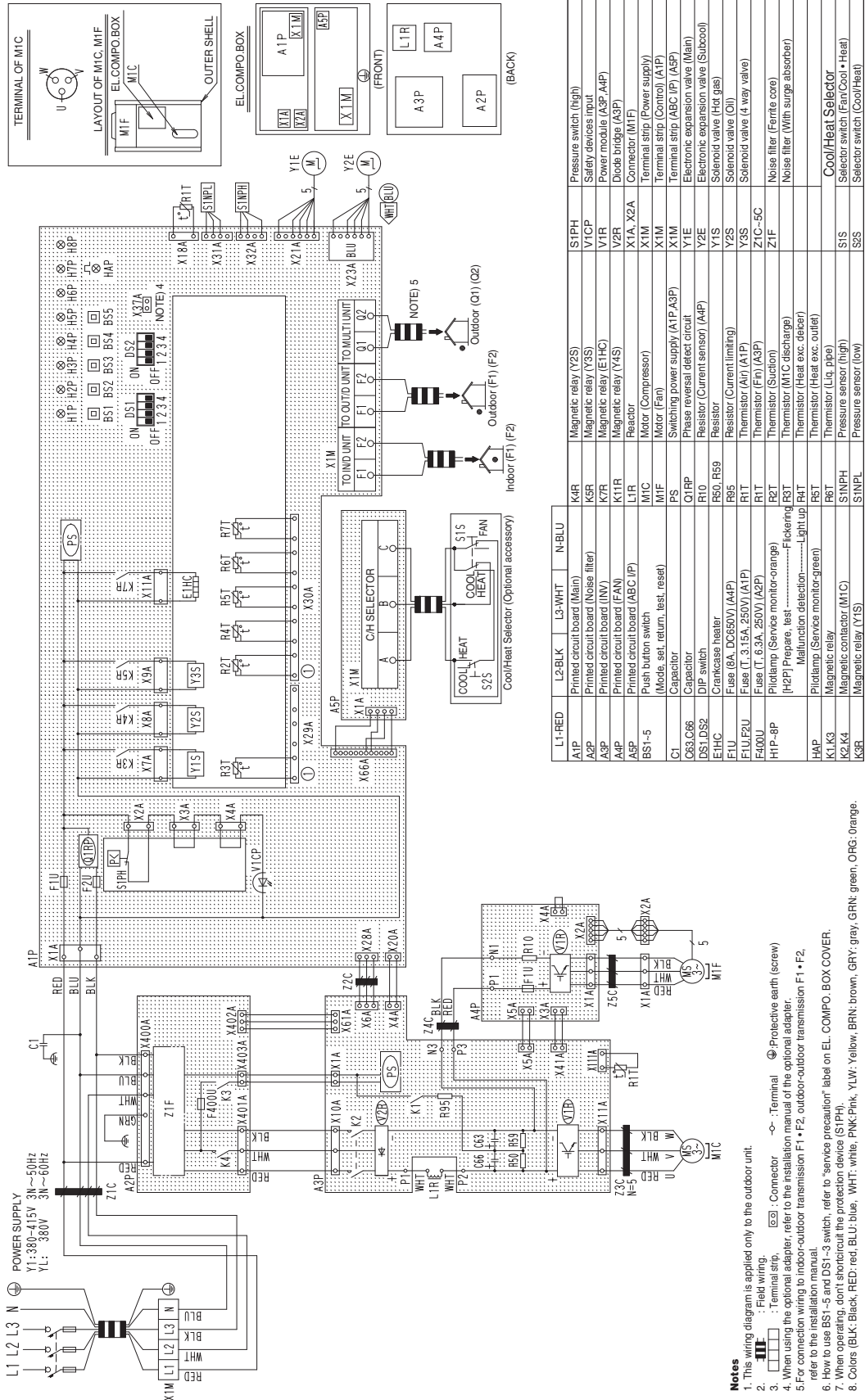

L1-RED	L2-BLK	L3-WHT	N-BLU	K4R	Magnetic relay (Y2S)	S1PH	Pressure switch (high)
A1P	Printed circuit board (Main)	K5R	Magnetic relay (Y3S)	V1CP	Safety devices input	V1TR	Power module (A3P, A4P)
A2P	Printed circuit board (Noise filter)	K7R	Magnetic relay (E1HC)	V2R	Diode bridge (A3P)	X1A, X2A	Connector (MIF)
A3P	Printed circuit board (FAN)	K11R	Reactor	X1M	Terminal strip (Power supply)	X1M	Terminal strip (Control) (A1P)
A4P	Printed circuit board (ABC IP)	L1R	Motor (Compressor)	Y1E	Terminal strip (ABC IP) (A3P)	Y2E	Electronic expansion valve (Main)
BSI-5	Push button switch (Mode, set, return, test, reset)	MIC	Motor (Fan)	Y1S	Resistor (Current sensor) (A4P)	Y2S	Electronic expansion valve (Subcool)
C1	Capacitor	O1RP	Phase reversal detect circuit	Y3S	Resistor	Z1C-5C	Solenoid valve (Hot gas)
D53, C66	DIP switch	R10	Crankcase heater	R1T	Resistor (Current limiting)	Z1F	Solenoid valve (4 way valve)
DS1, D52	DS1 switch	R50, R59	Fuse (T, 3.15A, 250V) (A1P)	R2T	Thermistor (Fm) (A1P)		Noise filter (Ferrite core)
E1HC	Crankcase heater	F1U, F2U	Fuse (T, 6.3A, 250V) (A2P)	R2T	Thermistor (Suction)		Noise filter (With surge absorber)
F1U	Fuse (T, 3.15A, 250V) (A4P)	H1P-8P	Pilotlamp (Service monitor-orange) (H2P) Prepare, test	R4T	Thermistor (Heat exc. delay)		
F400U	Fuse (T, 6.3A, 250V) (A2P)	L4P	Pilotlamp (Service monitor-green)	R5T	Thermistor (Heat exc. outlet)		
H1P-8P	Pilotlamp (Service monitor-orange)	K1, K3	Magnetic relay	S1NPH	Pressure sensor (high)		Cool/Heat Selector
HAP	Pilotlamp (Service monitor-green)	K2, K4	Magnetic relay	S1S	Pressure sensor (low)		Selector switch (Fan/Cool/Heat)
K1, K3	Magnetic relay	K3R	Magnetic relay (Y1S)	S2S	Selector switch (Cool/Heat)		

3D050464J

RXYQ8PY1, RXYQ8PYL

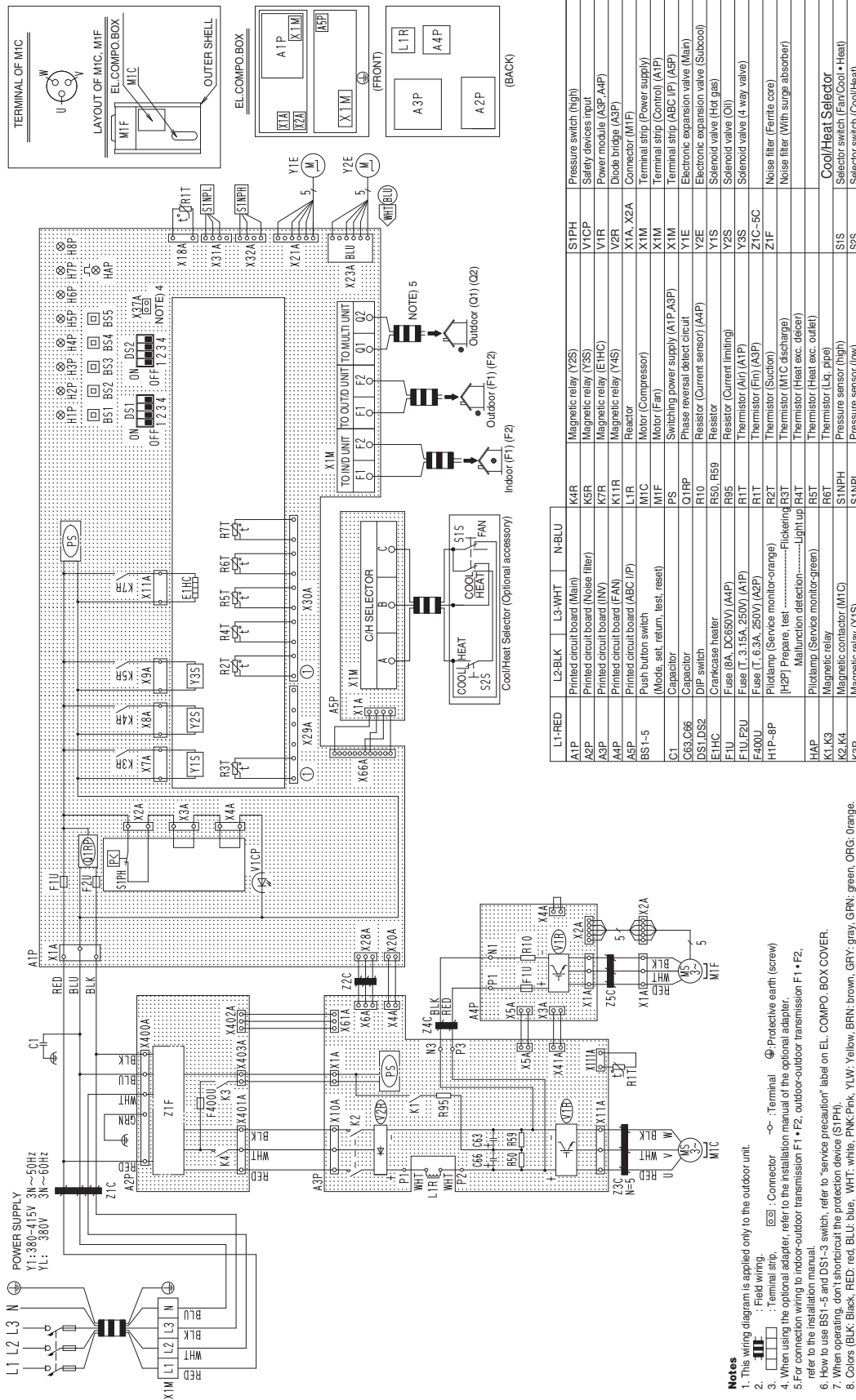

L1-RED	L2-BLK	L3-WHT	N-BLU	K4R	S1PH	Pressure switch (high)
A1P	Printed circuit board (Main)	A2P	Printed circuit board (Noise filter)	K5R	V1CP	Safety devices input
A3P	Printed circuit board (INV)	A4P	Printed circuit board (FAN)	K7R	V1FR	Power module (A3P, A4P)
A5P	Printed circuit board (ABC IP)	L1R	Reactor	V2R	X1A, X2A	Diode bridge (A3P)
BS1-5	Push button switch (Mode, set, return, test, reset)	MTC	Motor (Compressor)	X1M	Terminal strip (Power supply)	Connector (M1F)
C1	Capacitor	M1F	Motor (Fan)	X1M	Terminal strip (Control A1P)	Terminal strip (Control A1P)
C63, C66	Capacitor	PS	Switching power supply (A1P, A3P)	Y1E	X1M	Terminal strip (Control A1P)
DS1, DS2	DIP switch	Q1RP	Phase reversal detect circuit	Y2E	Y1S	Electronic expansion valve (Main)
E1HC	Crankcase heater	R10	Resistor (Current sensor) (A4P)	Y2S	Y2S	Electronic expansion valve (Subcool)
F1U, F2U	Fuse (6A, DC650V) (A4P)	R50, R59	Resistor	Y3S	Z1C-5C	Solenoid valve (Hot gas)
F400L	Fuse (T, 6.3A, 250V) (A2P)	R1T	Thermistor (Current limiting)	Z1F		Solenoid valve (4 way valve)
H1P-8P	Flidlamp (Service monitor-orange)	R2T	Thermistor (Fin) (A3P)			Noise filter (Ferrite core)
HAP	Flidlamp (Prepare, test)	R3T	Thermistor (MTC discharge)			Noise filter (With surge absorber)
K1, K3	Magnetic relay	R4T	Thermistor (Heat exc. detector)			
K2, K4	Magnetic contactor (MTC)	R5T	Thermistor (Heat exc. outlet)			
K3F	Magnetic relay (Y1S)	S1NPH	Pressure sensor (high)			
		S1NPL	Pressure sensor (low)			

3D050454J

RXYQ10PY1, RXYQ10PYL

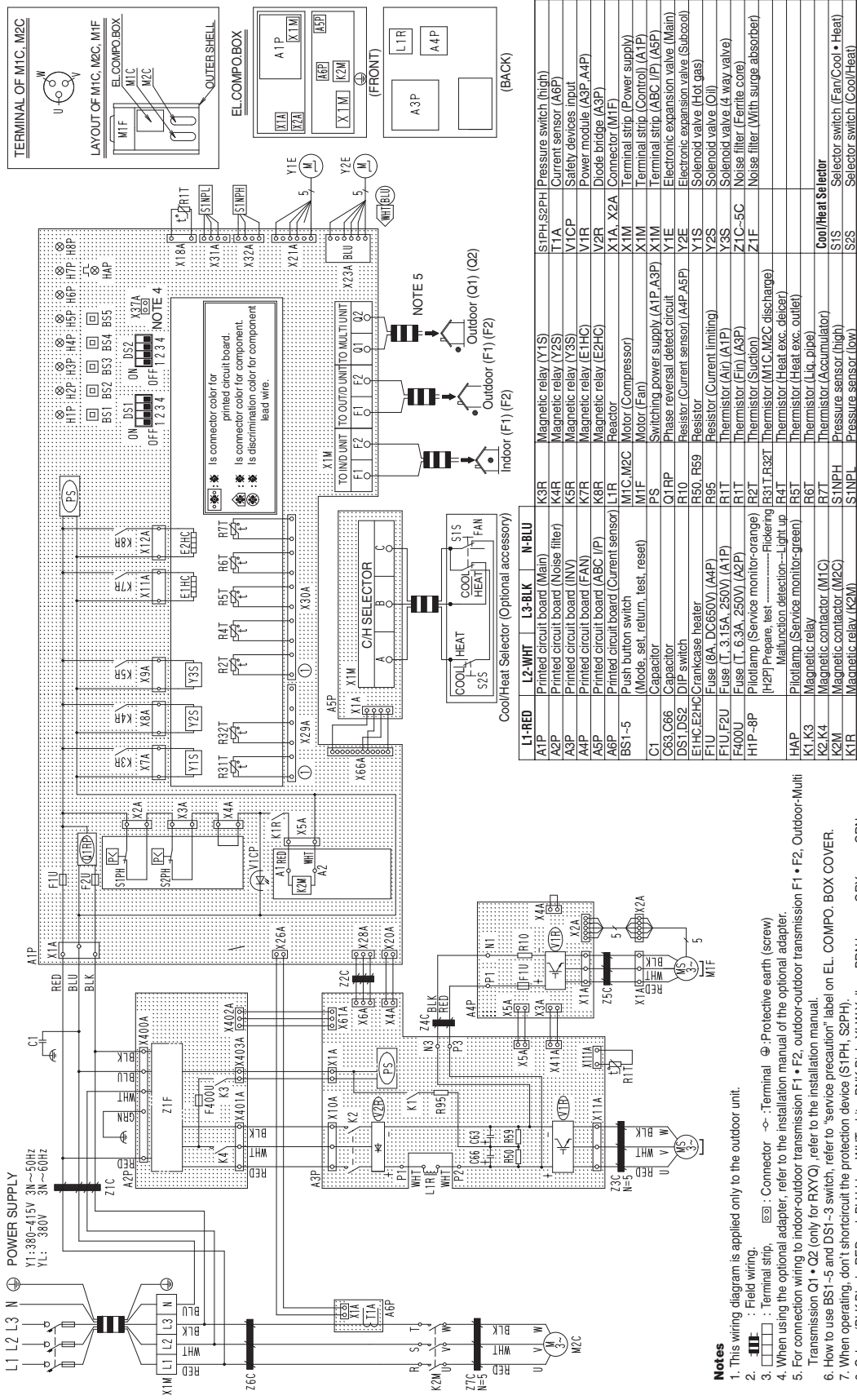

3D050455H

L1-RED	L2-WHT	L3-BLK	N-BLU	S1PH, S2PH	Pressure switch (high)
A1P	Printed circuit board (Main)	X3R	Magnetic relay (Y1S)	T1A	Current sensor (A6P)
A2P	Printed circuit board (Noise filter)	X4R	Magnetic relay (Y2S)	V1CP	Safety devices input
A3P	Printed circuit board (INV)	X5R	Magnetic relay (Y3S)	V1R	Power module (A3P, A4P)
A4P	Printed circuit board (FAN)	X6R	Magnetic relay (E1HC)	V2R	Diode bridge (A3P)
A5P	Printed circuit board (ABC I/P)	X7R	Magnetic relay (E2HC)	X1A, X2A	Connector (M1F)
A6P	Printed circuit board (Current sensor)	L1R	Reactor	X1M	Terminal strip (Power supply)
BS1-5	Push button switch	M1F	Motor (Compressor)	X1M	Terminal strip (Control) (A1P)
C1	Capacitor	O1RP	Motor (Fan)	X1M	Terminal strip (ABC I/P) (A5P)
C63, C66	Capacitor	PS	Switching power supply (A1P, A3P)	X1M	Terminal strip (Main)
DS1, DS2	DIP switch	R10	Phase reversal detect circuit	Y1E	Electronic expansion valve (Subcool)
E1HC, E2HC	Crankcase heater	R50, R59	Resistor (Current sensor) (A4P, A5P)	Y1S	Solenoid valve (Hot gas)
F1U	Fuse (6A, DC650V) (A4P)	R95	Resistor (Current limiting)	Y2S	Solenoid valve (Oil)
F1U, F2U	Fuse (T, 3.15A, 250V) (A1P)	R1T	Thermistor (Air) (A1P)	Y2S	Solenoid valve (4 way valve)
F400U	Fuse (T, 6.3A, 250V) (A2P)	R1T	Thermistor (Fin) (A3P)	Z1C-5C	Noise filter (Ferrite core)
H1P-8P	Pilotlamp (Service monitor-orange)	R2T	Thermistor (Suction)	Z1F	Noise filter (With surge absorber)
H2P	Prepare, test	R31T, R32T	Thermistor (Heat exc. outlet)		
HAP	Mallfunction detection—Light up	R4T	Thermistor (Heat exc. outlet)		
HAP	Pilotlamp (Service monitor-green)	R5T	Thermistor (Liq. pipe)		
K1, K3	Magnetic relay	R6T	Thermistor (Heat exc. outlet)		
K2, K4	Magnetic contactor (M1C)	R7T	Thermistor (Accumulator)		
K2M	Magnetic contactor (M2C)	S1NPH	Pressure sensor (high)		
K1R	Magnetic relay (K2M)	S1NPL	Pressure sensor (low)		

- Notes**
- This wiring diagram is applied only to the outdoor unit.
 - Field wiring.
 - Terminal strip.
 - When using the optional adapter, refer to the installation manual of the optional adapter.
 - For connection wiring to indoor-outdoor transmission F1 • F2, outdoor-outdoor transmission F1 • F2, Outdoor-Multi Transmission Q1 • Q2 (only for RXYQ), refer to the installation manual.
 - How to use BS1-5 and DS1-3 switch, refer to "service precaution" label on EL.COMPO.BOX COVER.
 - When operating, don't shortcircuit the protection device (S1PH, S2PH).
 - Colors (BLK:Black, RED:red, BLU:blue, WHT:white, PNK:Pink, YLW:Yellow, BRN:brown, GRY:gray, GRN:green, ORG:orange).

RXYQ12PY1, RXYQ12PYL

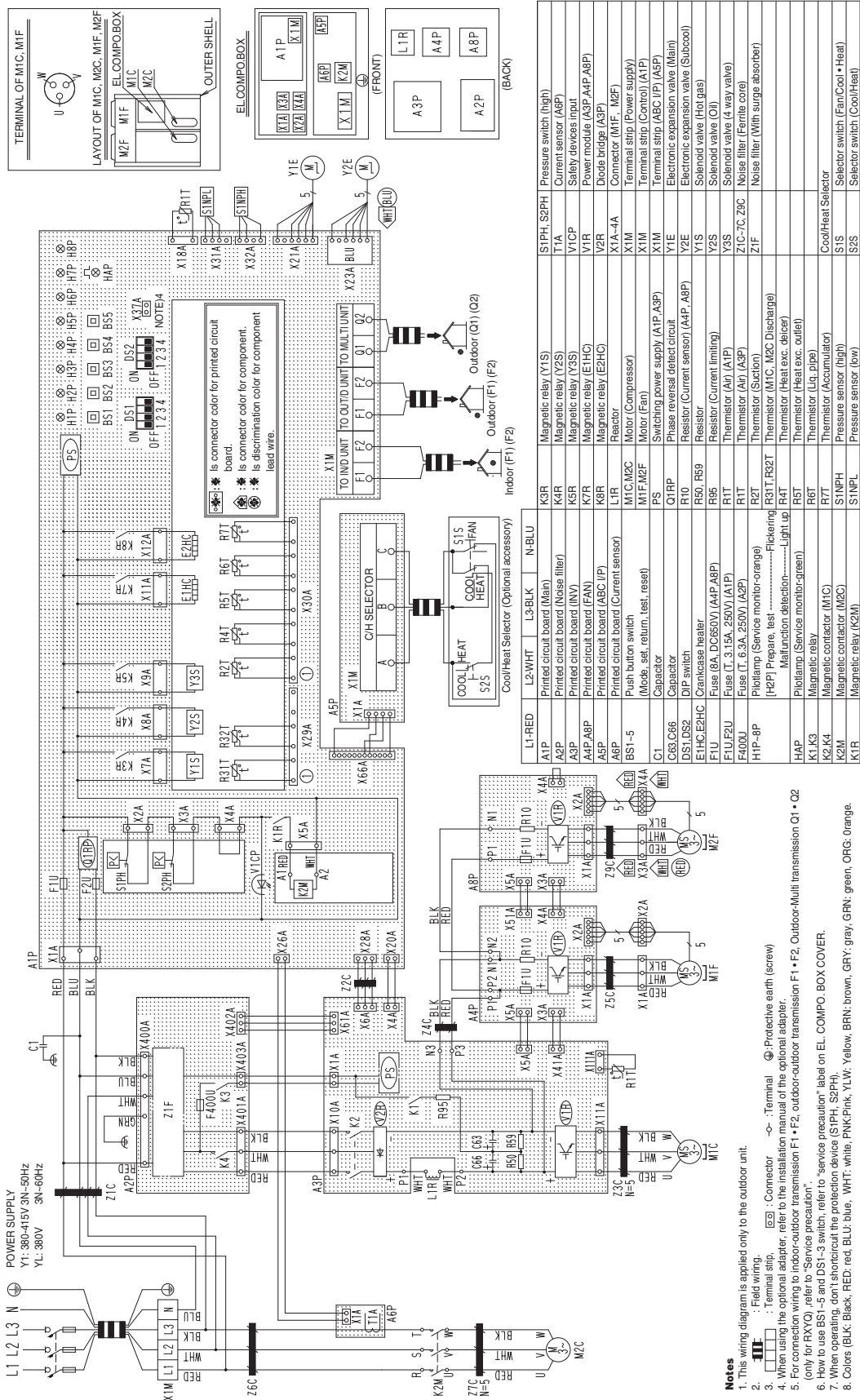

3D051890G

RXYQ14PY1, RXYQ16PY1, RXYQ18PY1
RXYQ14PYL, RXYQ16PYL, RXYQ18PYL

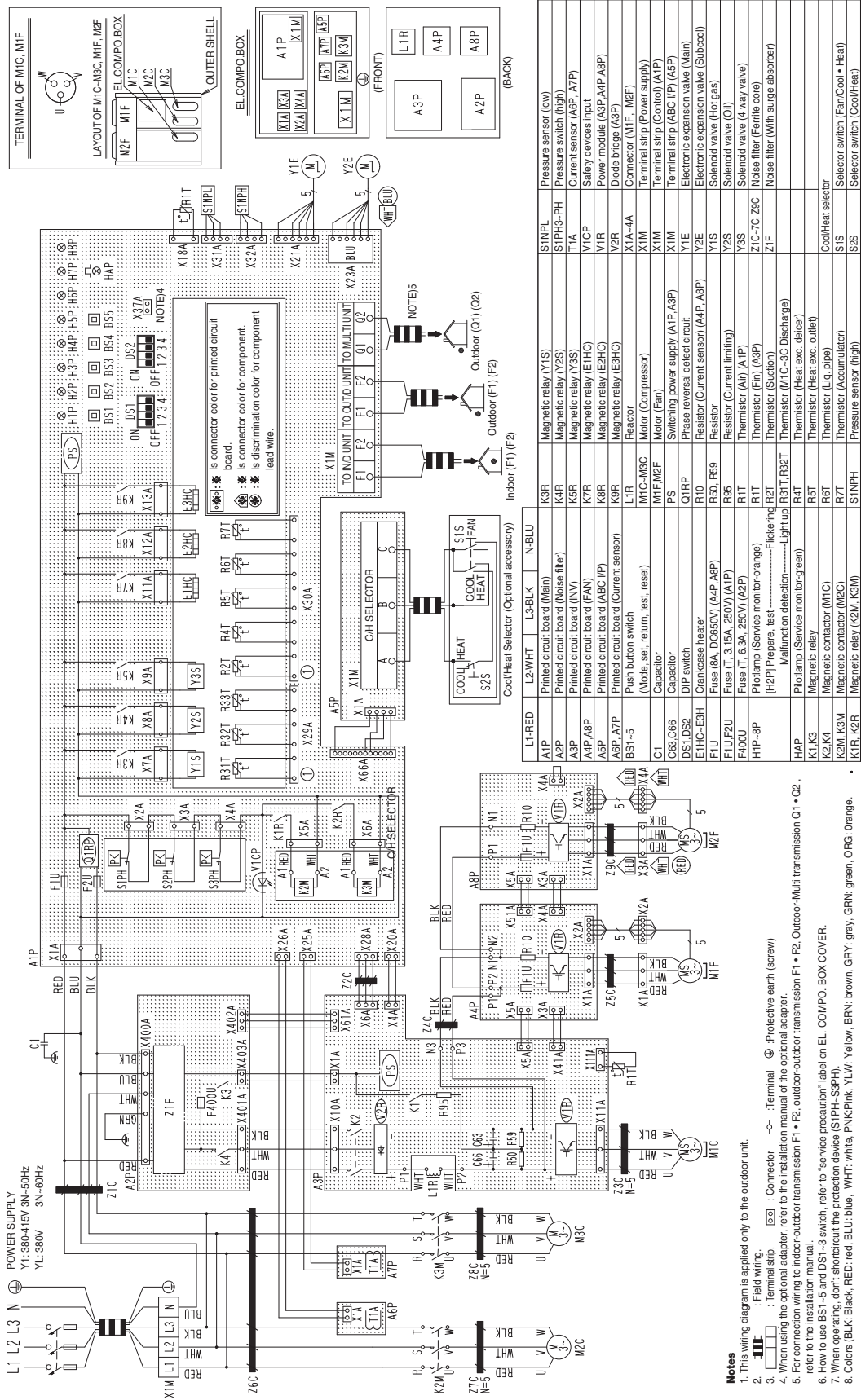

3D050456H

7.13.2 Cooling Only Outdoor Unit

RXQ5PY1

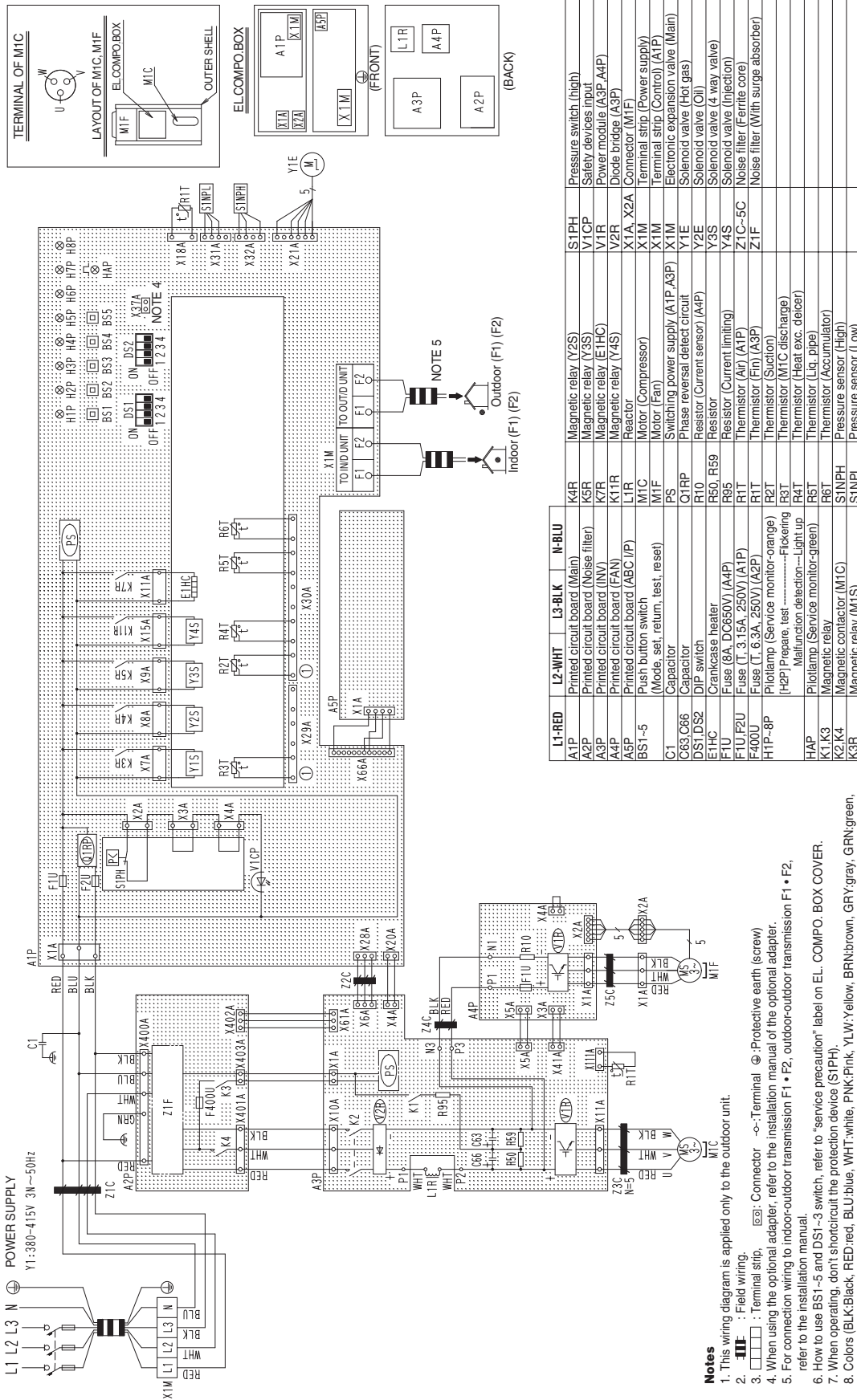

- Notes**
1. This wiring diagram is applied only to the outdoor unit.
 2. **III** : Field wiring.
 3. **III** : Terminal strip.
 4. When using the optional adapter, refer to the installation manual of the optional adapter.
 5. For connection wiring to indoor-outdoor transmission F1 • F2, outdoor-outdoor transmission F1 • F2, refer to the installation manual.
 6. How to use BS1-5 and DS1-3 switch, refer to "service precaution" label on EL. COMPO. BOX COVER.
 7. When operating, don't shortcircuit the protection device (S1PH).
 8. Colors (BLK:Black, RED:red, BLU:blue, WHT:white, PNK:Pink, YLW:Yellow, BRN:brown, GRY:gray, GRN:green, ORG:orange).

L1-RED	L2-WHT	L3-BLK	N-BLU		
A1P	K4R			Magnetic relay (Y2S)	S1PH
A2P	K5R			Magnetic relay (Y3S)	V1CP
A3P	K7R			Magnetic relay (E1HC)	V1R
A4P	K11R			Magnetic relay (Y4S)	V2R
A5P	L1R			Reactor	X1A, X2A
BS1-5	M1C			Motor (Compressor)	X1M
	M1F			Motor (Fan)	X1M
C1	PS			Switching power supply (A1P, A3P)	X1M
C63, C66	O1RP			Phase reversal detect circuit	V1E
DS1, DS2	R10			Resistor (Current sensor) (A4P)	Y2E
E1HC	R50, R59			Resistor (Current limiting)	Y3S
F1U	R95			Resistor (Current limiting)	Y4S
F1U, F2U	R1T			Thermistor (Air) (A1P)	Z1C-5C
F400U	R1T			Fuse (T, 3.15A, 250V) (A1P)	Z1F
F400U	R1T			Fuse (T, 6.3A, 250V) (A2P)	
H1P-8P	R2T			Pilotlamp (Service monitor-orange)	
	R3T			Pilotlamp (Service monitor-orange)	
	R4T			Thermistor (MTC discharge)	
	R4T			Thermistor (Heat exc. detector)	
HAP	R6T			Pilotlamp (Service monitor-green)	
K1, K3	R6T			Magnetic relay	
K2, K4	R6T			Magnetic relay	
K3R	S1MPH			Pressure sensor (High)	
	S1MPL			Pressure sensor (Low)	

3D055257A

RXQ8PY1

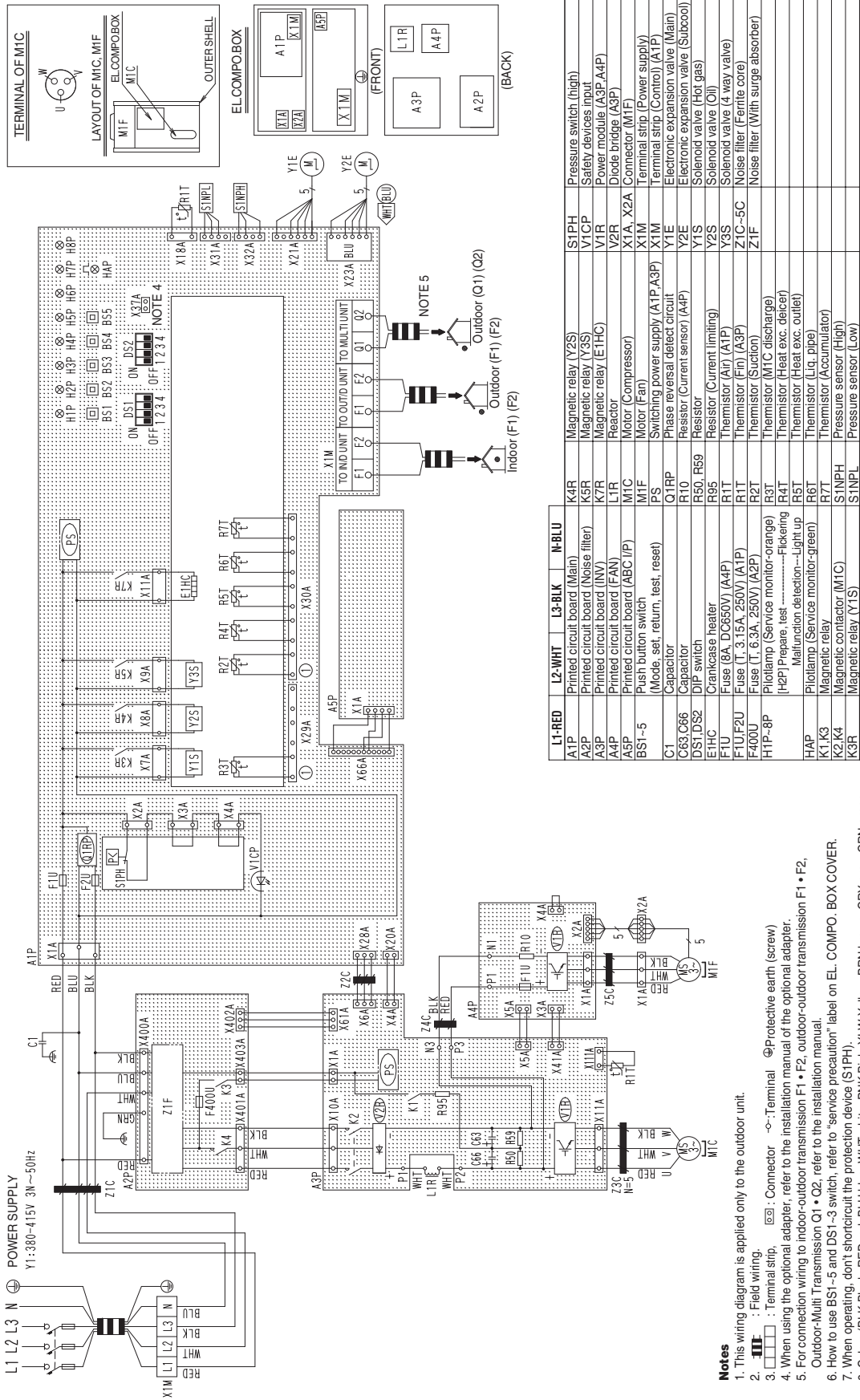

3D055258A

RXQ10PY1

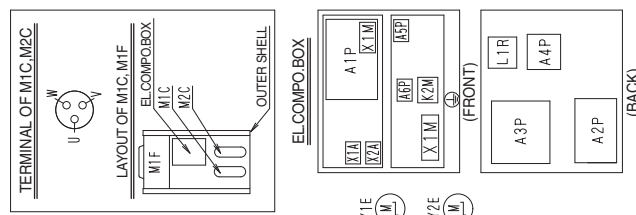
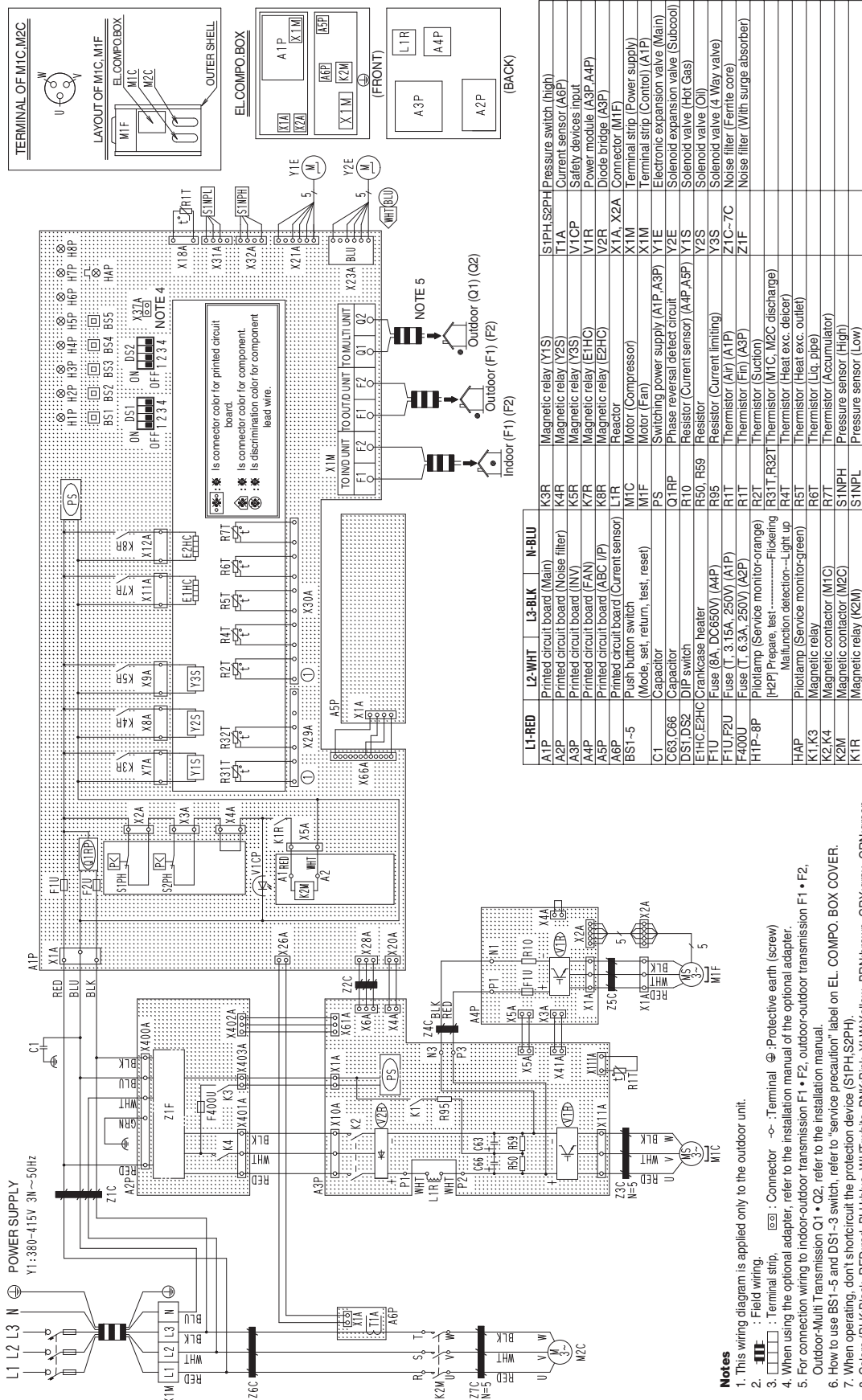

Component	Description
A1P	Printed circuit board (Main)
A2P	Printed circuit board (Noise filter)
A3P	Printed circuit board (INV)
A4P	Printed circuit board (FAN)
A5P	Printed circuit board (ABC /IP)
A6P	Printed circuit board (Current sensor)
BST-5	Push button switch
C1	Capacitor
C63, C66	DIP switch
DST, DS2	Diode
E1HC, E2HC	Crankcase heater
F1U, F2U	Fuse (6A, DC650V) (A4P)
F400U	Fuse (T: 3.15A, 250V) (A1P)
F400U	Fuse (T: 6.3A, 250V) (A2P)
H1P-8P	Pilotlamp (Service monitor-orange)
H1P-8P	Pilotlamp (Service monitor-green)
HAP	Thermistor (Heat exc. deicer)
K1, K3	Thermistor (Heat exc. outlet)
K2, K4	Thermistor (Liq. pipe)
K2M	Magnetic contactor (M1C)
K1R	Magnetic contactor (M2C)
K1R	Magnetic relay (K2M)
K3R	Magnetic relay (Y1S)
K4R	Magnetic relay (Y2S)
K5R	Magnetic relay (Y3S)
K7R	Magnetic relay (E1HC)
K8R	Magnetic relay (E2HC)
L1R	Reactor
MTC	Motor (Compressor)
MIF	Motor (Fan)
O1RP	Phase reversal detect circuit
R10	Resistor (Current sensor) (A4P, A5P)
R50, R59	Resistor (Current limiting)
R95	Resistor
R11	Thermistor (A1) (A1P)
R11	Thermistor (Fm) (A3P)
R21	Thermistor (Suction)
R31T, R32T	Thermistor (MTC, M2C discharge)
R41	Thermistor (Heat exc. deicer)
R51	Thermistor (Heat exc. outlet)
R61	Thermistor (Liq. pipe)
R71	Thermistor (Accumulator)
R77	Pressure sensor (High)
R77	Pressure sensor (Low)
S1NPH	Pressure sensor (High)
S1NPL	Pressure sensor (Low)
S1PH, S2PH	Pressure switch (high)
T1A	Current sensor (A6P)
V1CP	Safety devices input
V1R	Power module (A3P, A4P)
V2R	Diode bridge (A3P)
X1A, X2A	Connector (MIF)
X1M	Terminal strip (Power supply)
X1M	Terminal strip (Control) (A1P)
Y1E	Electronic expansion valve (Main)
Y2E	Electronic expansion valve (Subcool)
Y2S	Solenoid valve (Hot Gas)
Y3S	Solenoid valve (Oil)
Z1C-7C	Solenoid valve (4 Way valve)
Z1F	Noise filter (Ferrite core)
Z1F	Noise filter (With surge absorber)

- Notes**
- This wiring diagram is applied only to the outdoor unit.
 - Terminal symbol: Connector → Terminal ⊕: Protective earth (screw)
 - Field wiring symbol: Field wiring
 - When using the optional adapter, refer to the installation manual of the optional adapter.
 - For connection wiring to indoor-outdoor transmission F1 • F2, outdoor-outdoor transmission F1 • F2, Outdoor-Multi Transmission Q1 • Q2, refer to the installation manual.
 - How to use BST-5 and DST-3 switch, refer to 'service precaution' label on EL COMPO. BOX COVER.
 - When operating, don't shortcircuit the protection device (S1PH, S2PH).
 - Colors (BLK:Black, RED:red, BLU:blue, WHT:white, PNK:Pink, YLW:Yellow, BRN:brown, GRY:gray, GRN:green, ORG:orange).

3D055259A

RXQ12PY1

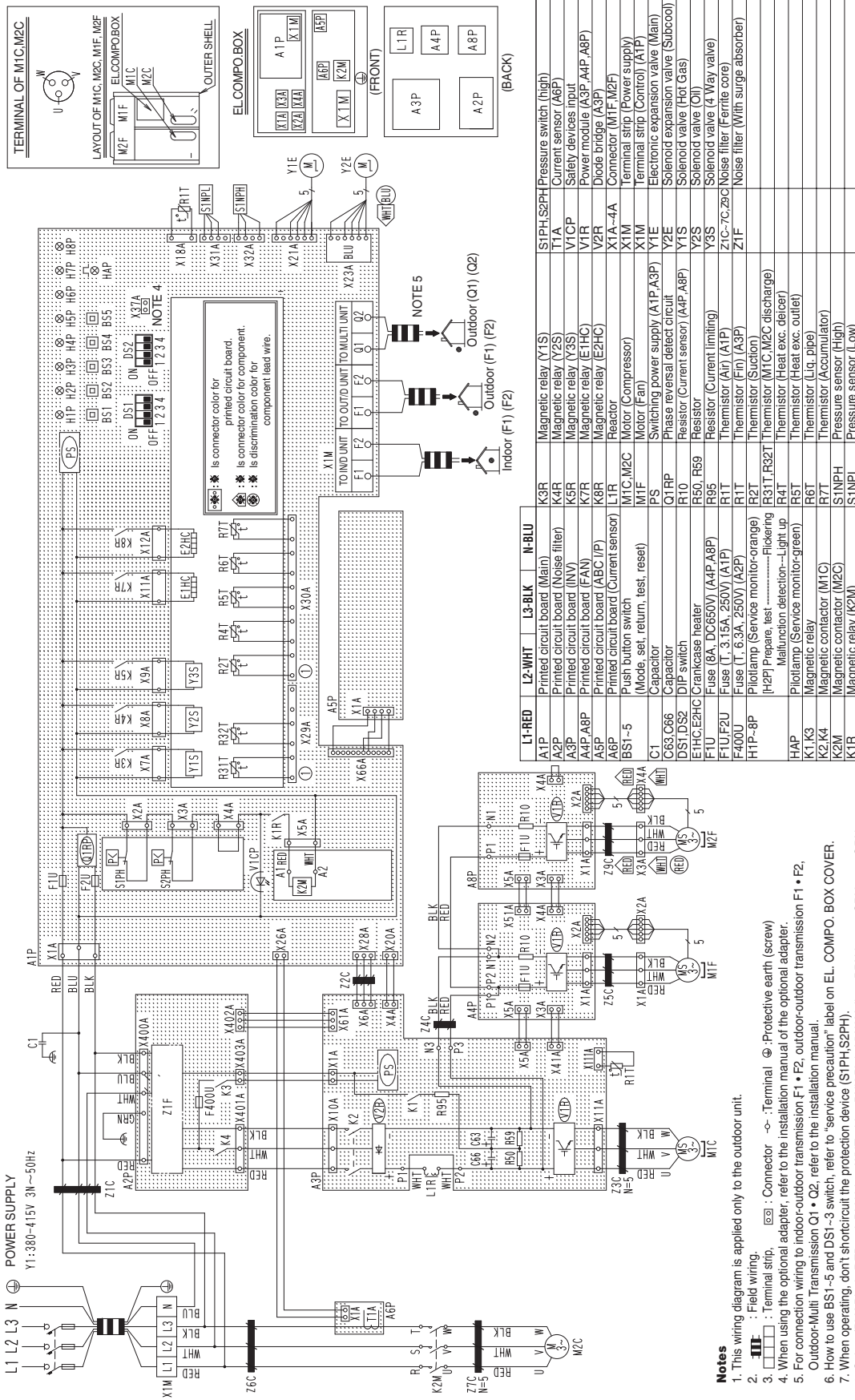

3D055260A

RXQ14PY1, RXQ16PY1, RXQ18PY1

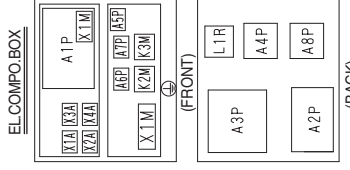
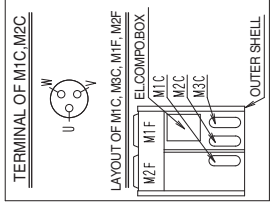
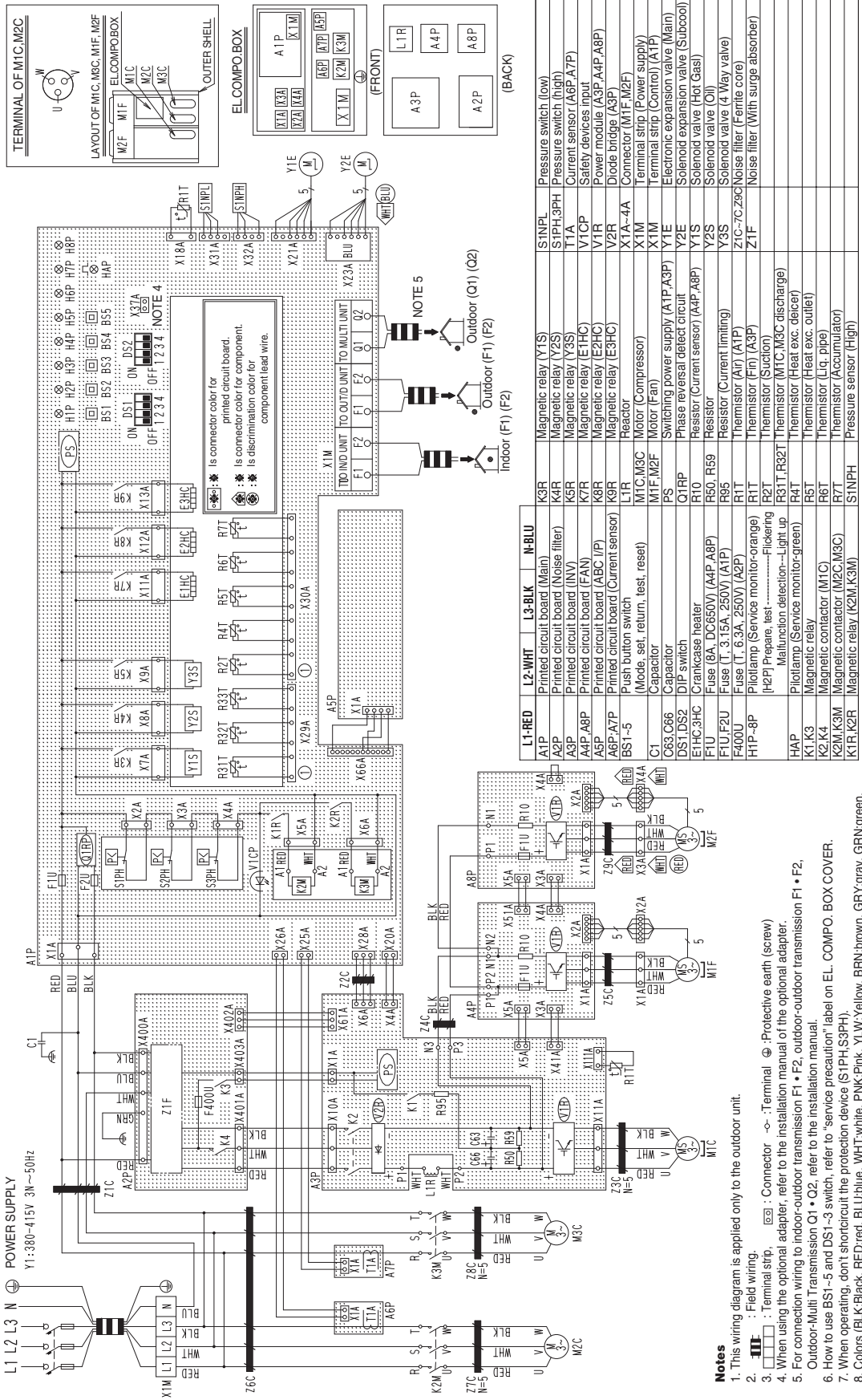

LT-RED	L2-WHT	L3-BLK	N-BLU	Component
A1P	K3R	K4R	SINPL	Pressure switch (low)
A2P	K5R	K6R	SIPH_3PH	Pressure switch (high)
A3P	K7R	K8R	T1A	Current sensor (A6P, A7P)
A4P, A8P	K9R	K1R	V1CP	Safety devices input
A5P	K2R	K3R	V1R	Power module (A3P, A4P, A8P)
A6P, A7P	K4R	K5R	V2R	Diode bridge (A3P)
BS1-5	L1R	L2R	X1A-4A	Connector (M1F, M2F)
C1	MTC, M3C	M1F, M2F	X1M	Terminal strip (Power supply)
C63, C66	PS	PS	X1M	Terminal strip (Control) (A1P)
DS1, DS2	Q1RP	Q1RP	Y1E	Electronic expansion valve (Main)
E1HC, 3HC	R10	R50, R59	Y2E	Solenoid expansion valve (Subcool)
F1U	R85	R85	Y2S	Solenoid valve (Oil)
F1U, F2U	R95	R95	Y3S	Solenoid valve (4 Way valve)
F400U	R1T	R1T	Z1C-7C, Z9C	Noise filter (Ferrite core)
H1P-8P	R2T	R2T	Z1F	Noise filter (With surge absorber)
HAP	R31T, R32T	R31T, R32T		
K1, K3	R4T	R4T		
K2, K4	R5T	R5T		
K2M, K3M	R6T	R6T		
K1R, K2R	R7T	R7T		
	SINPH	SINPH		

- Notes**
1. This wiring diagram is applied only to the outdoor unit.
 2. : Terminal
 3. : Field wiring.
 4. When using the optional adapter, refer to the installation manual of the optional adapter.
 5. For connection wiring to indoor-outdoor transmission F1 • F2, outdoor-outdoor transmission F1 • F2, Outdoor-Multi Transmission Q1 • Q2, refer to the installation manual.
 6. How to use BS1-5 and DS1-3 switch, refer to "service precaution" label on EL COMPO BOX COVER.
 7. When operating, don't short-circuit the protection device (STPH, S3PH).
 8. Colors (BLK:Black, RED:red, BLU:blue, WHT:white, PNK:Pink, YLW:yellow, BRN:brown, GRY:gray, GRN:green, ORG:orange).

3D055261A

7.13.3 Field Wiring Heat Pump, Cooling Only (50Hz/60Hz)

RX(Y)Q5P, 8P, 10P, 12P, 14P, 16P, 18PY1

RXYQ5P, 8P, 10P, 12P, 14P, 16P, 18PYL

3D051452D

6. Unit shall be grounded in compliance with the applicable local and national codes.
 7. Wiring shown are general points-of-connection guides only and are not intended for or to include all details for a specific installation.
 8. Be sure to install the switch and the fuse to the power line of each equipment
 9. because this system consists of the equipment utilizing the multiple power sources.
 10. if there exists the possibility of reversed phase, lose phase, momentary blackout or the power goes on and off while the product is operating, attach a reversed phase protection circuit locally.
- Running the product in reversed phase may break the compressor and other parts.

- NOTES
1. All wiring, components and materials to be produced on the site must comply with the applicable local and national codes.
 2. Use copper conductors only.
 3. As for details, see wiring diagram.
 4. Install circuit breaker for safety.
 5. All field wiring and components must be provided by licensed electrician.

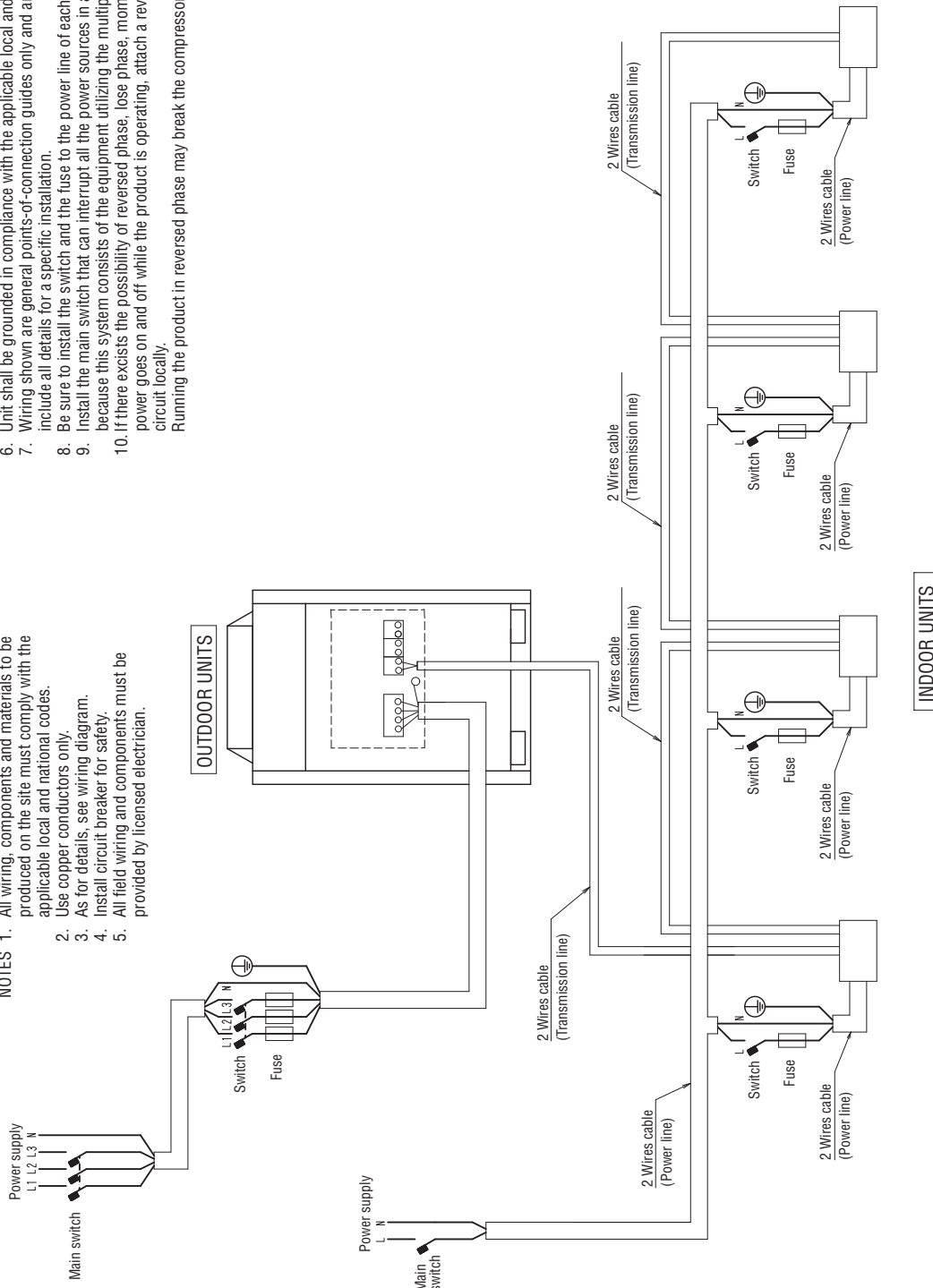

RX(Y)Q20P, 22P, 24P, 26P, 28P, 30P, 32P, 34P, 36PY1
RXYQ20P, 22P, 24P, 26P, 28P, 30P, 32P, 34P, 36PYL

Notes

- 1) All wiring, components and materials to be procured on the site must comply with the applicable local and national codes.
 - 2) Use copper conductors only.
 - 3) As for details, see wiring diagram.
 - 4) Install circuit breaker for safety.
 - 5) All field wiring and components must be provided by licensed electrician.
 - 6) Unit shall be grounded in compliance with the applicable local and national codes.
 - 7) Wiring shown are general points-of-connection guides only are not intended for or to include all details for or to specific installation.
 - 8) Be sure to install the switch and the fuse to the power line of each equipment.
 - 9) Install the main switch that can interrupt all the power sources in an integrated manner because this system consists of the equipment utilizing the multiple power sources.
 - 10) The capacity of UNIT 1 must be larger than UNIT 2 when the power source is connected in series between the units.
 - 11) If there exists the possibility of reversed phase, loose phase, momentary blackout or the power goes on and off while the product is operating, attach a reversed phase protection circuit locally.
- Running the product in reversed phase may break the compressor and other parts.

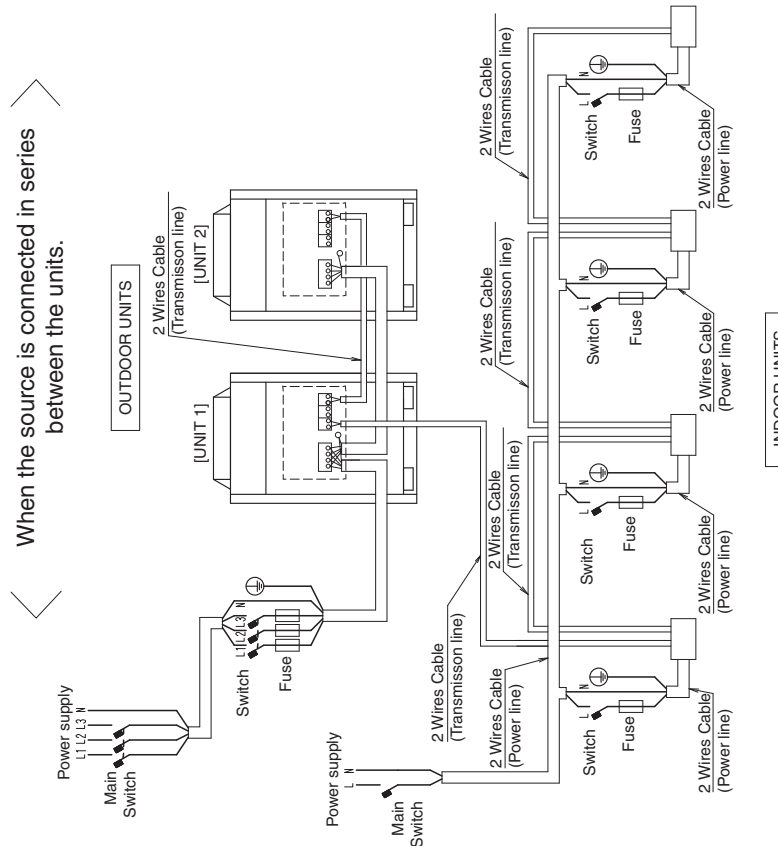
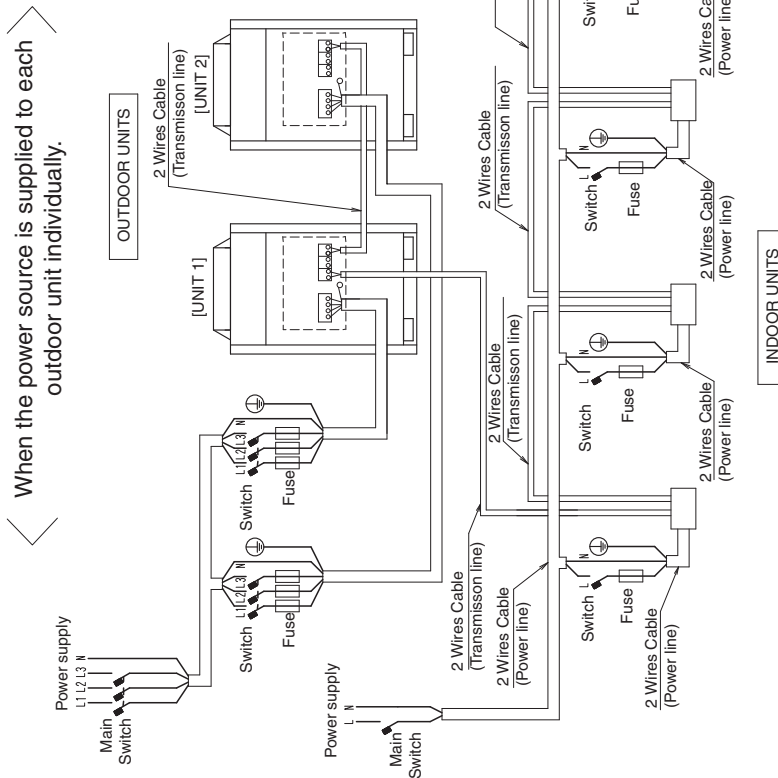

3D052261B

RX(Y)Q38P, 40P, 42P, 44P, 46P, 48P, 50P, 52P, 54PY1
RXYQ238P, 40P, 42P, 44P, 46P, 48P, 50P, 52P, 54PYL

Notes

- 1) All wiring, components and materials to be procured on the site must comply with the applicable local and national codes.
 - 2) Use copper conductors only.
 - 3) As for details, see wiring diagram.
 - 4) Install circuit breaker for safety.
 - 5) All field wiring and components must be provided by licensed electrician.
 - 6) Unit shall be grounded in compliance with the applicable local and national codes.
 - 7) Wiring shown are general points-of-connection guides only are not intended for or to include all details for or to specific installation.
 - 8) Be sure to install the switch and the fuse to the power line of each equipment.
 - 9) Install the main switch that can interrupt all the power sources in an integrated manner because this system consists of the equipment utilizing the multiple power sources.
 - 10) The capacity of UNIT1 must be larger than UNIT2.
 - 11) If there exists the possibility of reversed phase, lose phase, momentary blackout or the power goes on and off while the product is operating, attach a reversed phase protection circuit locally.
- Running the product in reversed phase may break the compressor and other parts.

When the power source is supplied to each outdoor unit individually.

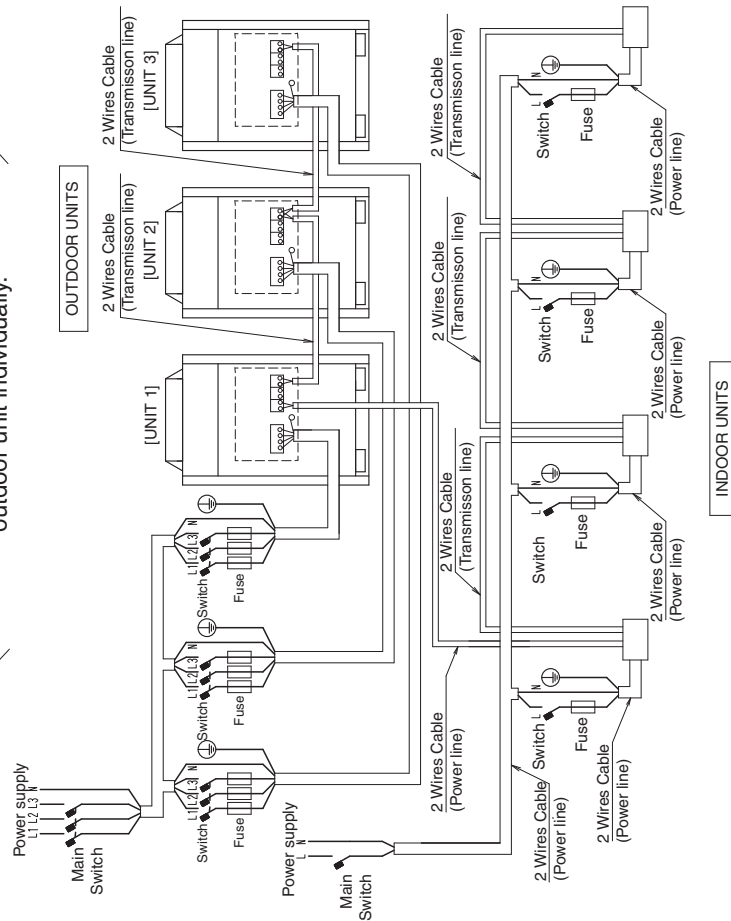

When the power source is connected in series between the units.

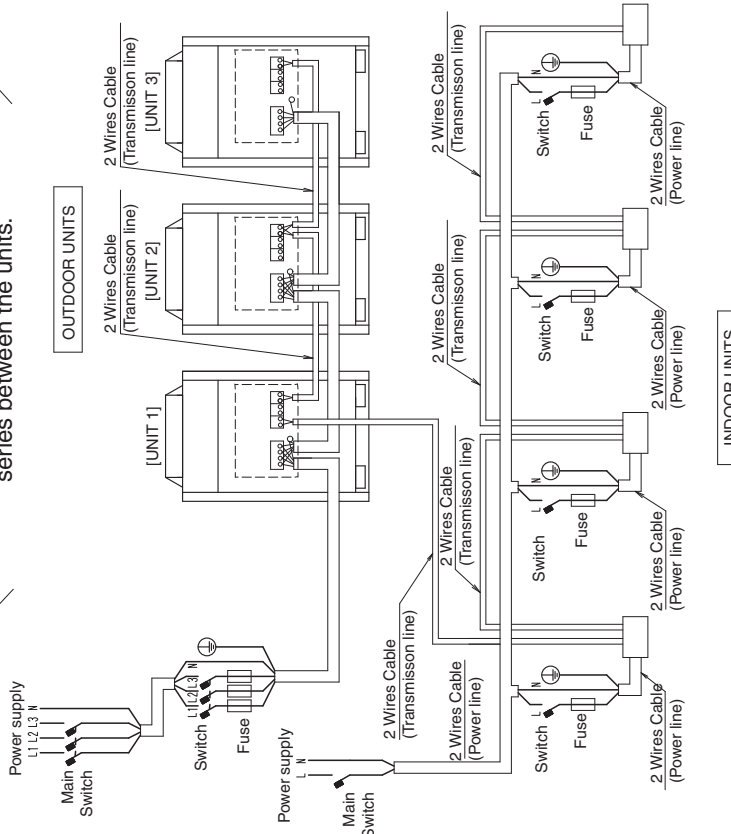

C: 3D052262B

7.14 Bad Examples and Good Examples in Installation

7.14.1 Example 1: Signal Interference due to Use of Multiple Core Cable (All Model)

Situation

Although for the purposes of group control there are only 2 units per group there are transmission malfunctions between the indoor units and the remote control and the remote control's address display is showing non-existent addresses such as 13 or 15.

Source of Problem and Remedial Action

Multiple core cable has been used for at least part of the interconnecting wiring between the remote control and the indoor units.

This has resulted in signal interference leading to a transmission malfunction.

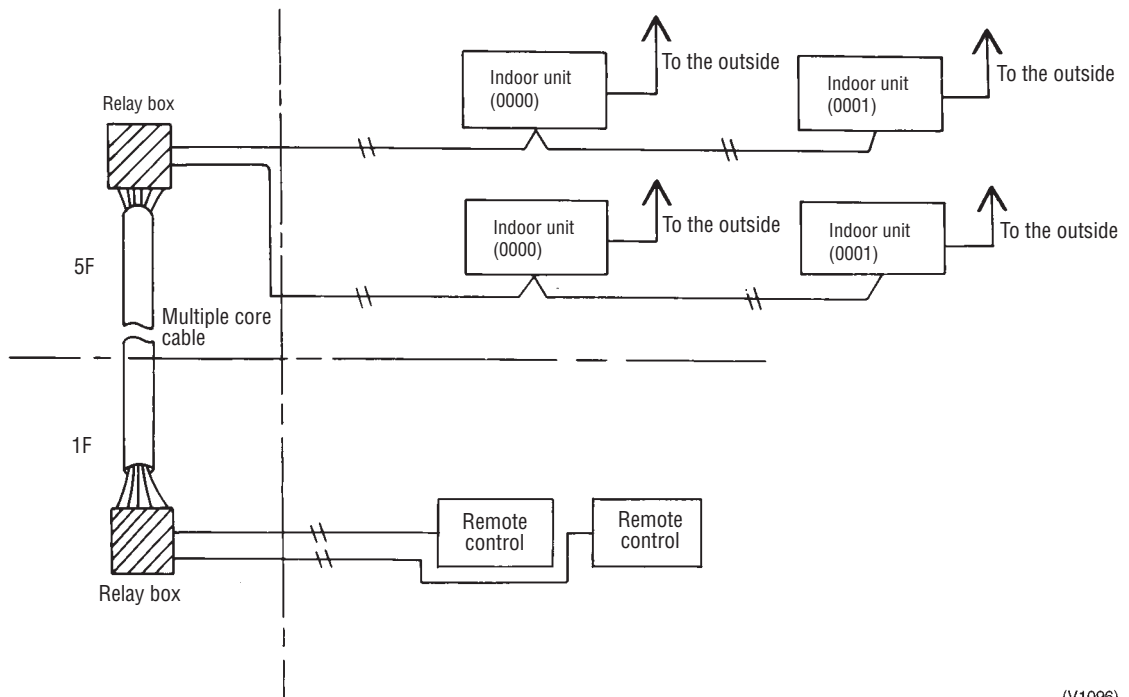

The multiple core cable was replaced by twin core cable and the fault disappeared.

Main Points

- Although twin core cable had been run from each unit, multiple core cable was used on the way.
- In schools, etc., because remote controls are often installed in a single first floor control room, it is easier to use a multi-core cable.
- Signal interference can result in non-existent addresses appearing on the display.

7.14.2 Example 2: Mismatch between Cables Connecting Indoor and Outdoor Units and Corresponding Piping (All Model)

Situation

The remote control is not showing any malfunction and the system is operating but there is no flow of warm air from the indoor unit (in heating mode).

Source of Problem and Remedial Action

The connecting cables and the corresponding piping were not correctly matched.
Recabling was carried out and the fault disappeared.

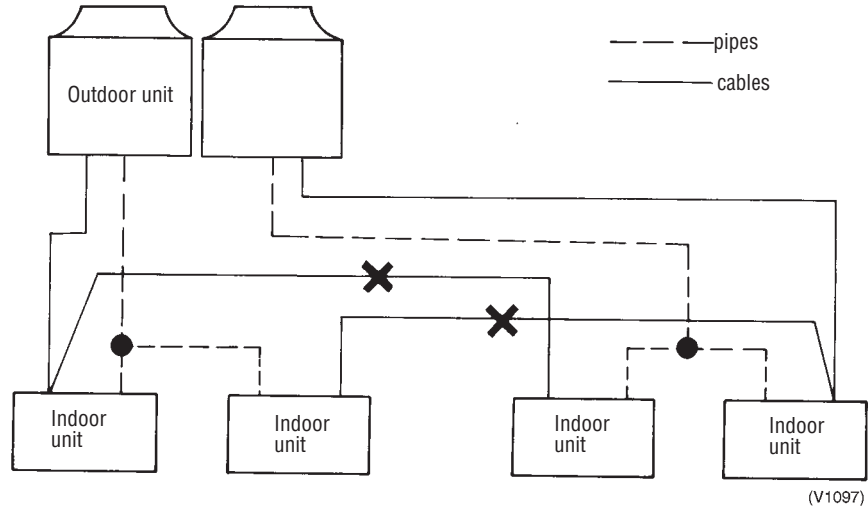

Main Points

- Special care must be taken when the pipework and cabling are carried out by different people.
- Run each indoor unit in turn to check that the system is correctly matched.

7.14.3 Example 3: Drain Pipe Trap Shape Defective

Situation

Indoor unit was fitted with a drain trap but a leak occurred during subsequent operation.

Source of Problem and Remedial Action

The trap was not properly shaped thus preventing it from functioning effectively as a trap and resulting in drain leakage. The trap was reshaped and the fault disappeared.

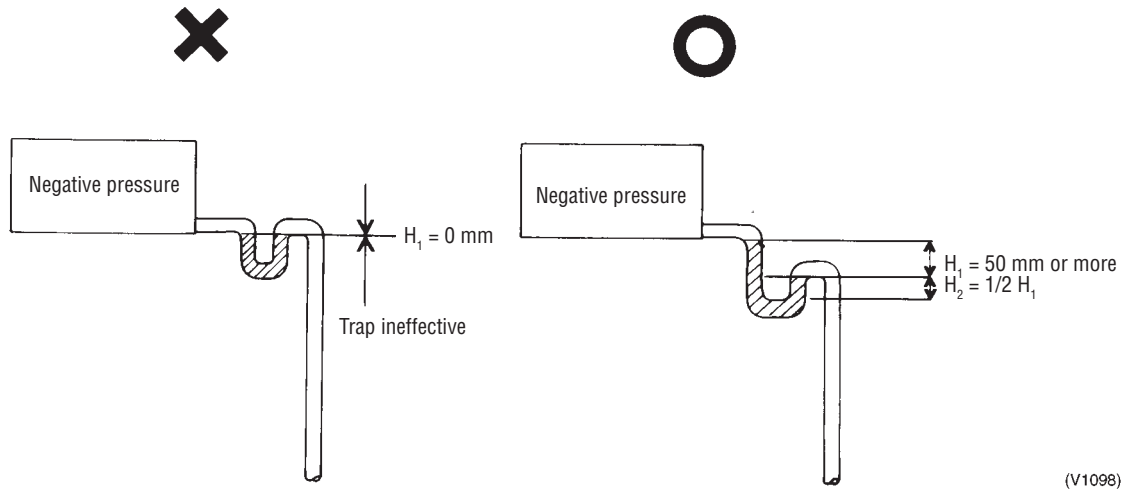

Main Points

- Duct types (40~125) require a drain trap.
 Reason: There is resistance on the air inlet side caused by the heat exchanger and air filter and this in turn creates negative pressure in relation to the atmospheric pressure on the discharge side. If there is no drain trap then air will be drawn in from the drain pipe and the waste water splashed around giving rise to the risk of water overflowing from the drain pan. To avoid this problem it is therefore necessary to design a trap which takes account of the maximum negative pressure which is likely to be created on the suction side.

7.14.4 Example 4: Pressure down Despite Absence of Leaks during Air Tight Test (All Model)

Situation

In order to carry out local air tight tests on the refrigerant piping the system was pressurized via the liquid pipe service port and after 24 hours the pressure was found to have fallen. The local refrigerant piping alone does not lose any pressure. Maybe the gas leak is supposed to be located in the indoor unit itself.

Source of Problem and Remedial Action

The system was pressurized from the liquid pipe side and the gas pipes were therefore not pressurized. The system was then left under pressure for 24 hours but during that time gas leaked through into the gas pipes due to internal leaks within electronic expansion valves and the gas pressure inside the liquid pipes consequently dropped.

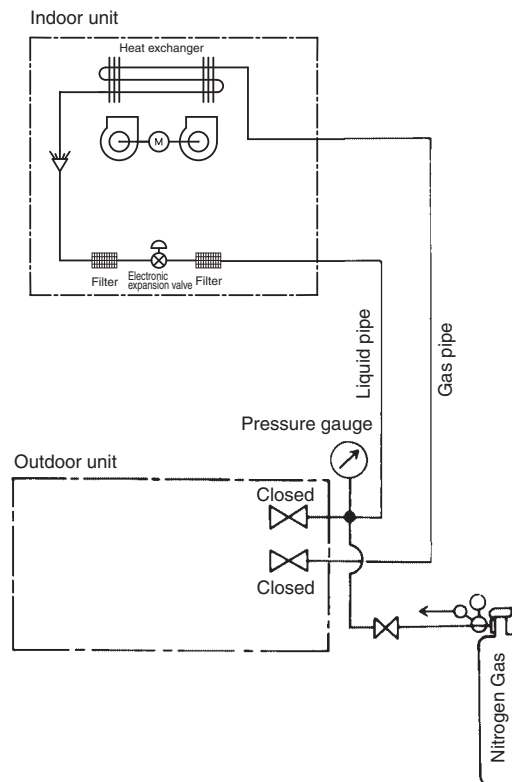

Main Points

When carrying out air tight tests on local pipework it is **essential that the system be pressurized via both the liquid pipes and the gas pipes.**

7.14.5 Example 5: Excessive Noise due to Incorrect Angling of REFNET Joints

Situation

The noise of the refrigerant flow during defrosting is excessive.

Source of Problem and Remedial Action

The angle of the fittings was incorrect and needed to be rectified as shown in the following figure.

1. REFNET joints

The REFNET joints should be installed such that branches meet the main pipe either horizontally or vertically at an angle of exactly 90 degrees.

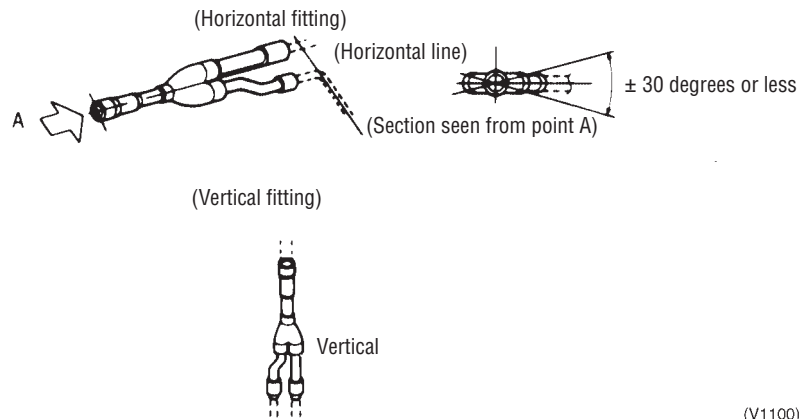

2. REFNET header

The REFNET header is a lateral flow pipe and should be fitted so as to allow horizontal branch fittings. (Vertical or sloping fitting is not permissible.)

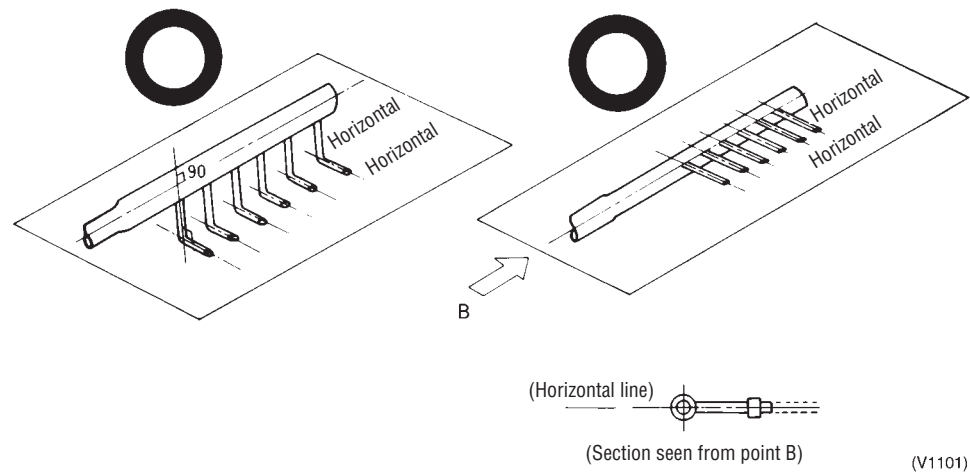

Main Points

■ Reasons for using refrigerant branch kit

Fittings of REFNET joints or headers which are not carried out in strict accordance with the principles outlined here may result in complaints relating, for example, to “poor performance” of the system or “noisy refrigerant flow”. (To prevent unbalance flow or oil shortage)

7.14.6 Example 6: Cracks Develop in Field Pipes due to Thermal Expansion and Contraction

Situation Refrigerant piping has developed cracks in soldered points and is leaking gas.

Cause Both ends of the pipe have been tightly fixed in place.
 ↓
 Starting and stopping the compressor has caused temperature to vary, thus the pipes have expanded and contracted which places stress on soldered parts.
 ↓
 Cracks have formed because of repeated expansion and contraction.

Remedial Action Fit the pipe with a loop as shown in the below drawing.

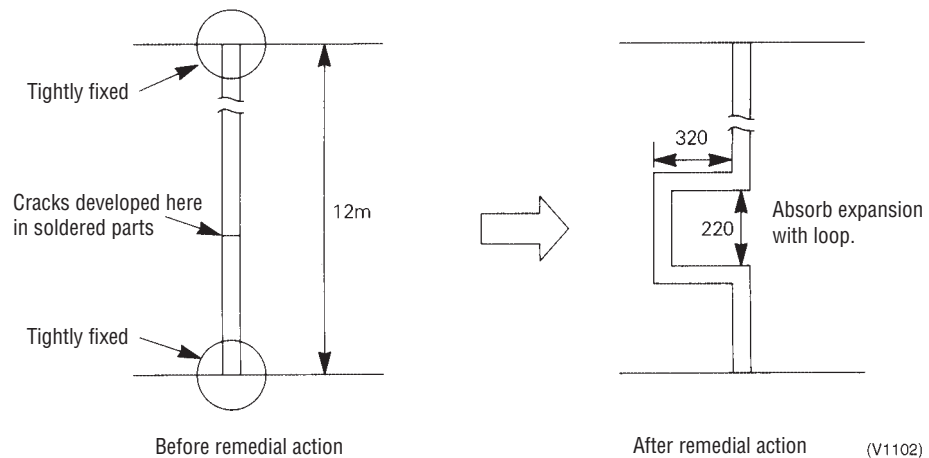

Main Points ■ Take thermal expansion and contraction along the spline into consideration when installing pipe supports.

For Your Reference Expansion (m) = Full length × Coefficient of thermal expansion × Rise in temperature
 Coefficient of thermal expansion for copper: 16.5×10^{-6}

Example For a pipe length of 10 m and a rise in temperature of 50°C, expansion reaches 8.2 mm.

7.14.7 Example 7: Transmission Wiring between the Cool/heat Selector and the Outdoor Unit is too Close to a High Voltage Wire.

Situation Heating is indicated despite having selected cooling with the cool/heat selector.

Cause and Remedial Action The transmission wiring between the cool/heat selector and the outdoor unit is too close to a high voltage wire. An induced voltage is, therefore, being impressed on the transmission wiring which is causing a heating/cooling malfunction in the outdoor unit PC board.

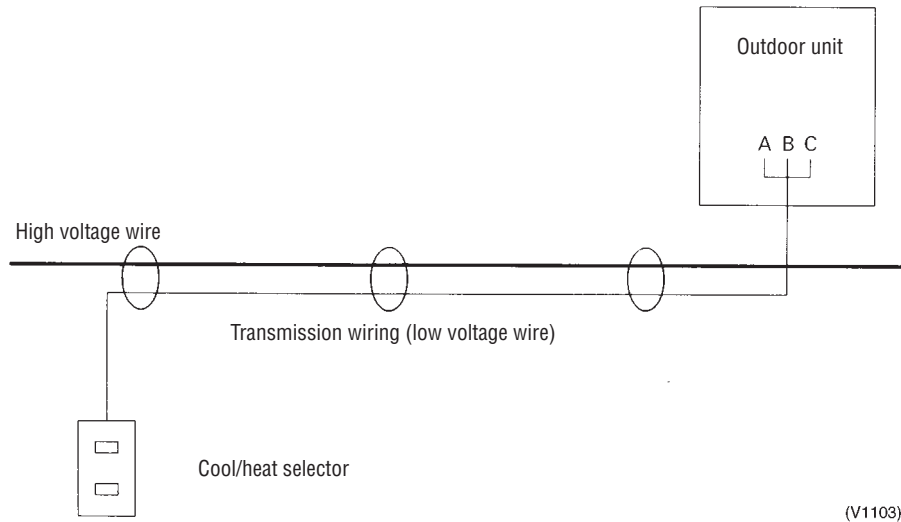

Bypassing the transmission wiring will allow the unit to function normally.

Main Points ■ Keep low and high voltage wiring away from each another.

7.14.8 Example 8: The Centralized Control Group Number cannot be Set (Inverter K Series).

Situation An attempt was made to set the centralized control group number with the indoor unit remote control, but “00” cannot be selected in the field setting mode.

Cause

1. The central remote control or unified ON/OFF controller is OFF.
2. The central remote control or unified ON/OFF controller, or indoor unit is not wired to the centralized control line (F1 & F2).

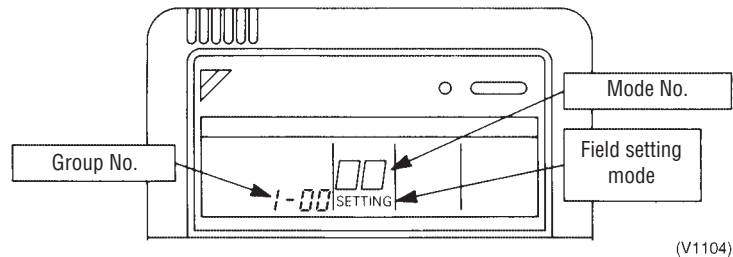

Remedial Action Supply power to either the central remote control or unified ON/OFF controller. Wire the central remote control or unified ON/OFF controller, or indoor unit to the centralized control line.

Main Points

- When communications with the central remote control are down, “00” cannot be selected in the field setting mode.
- Activate power to the central remote control, unified ON/OFF controller and indoor unit before setting the centralized control group number.

7.14.9 Example 9: “88” cannot be Cleared from the Central Remote Control.

Situation

The display on the central remote control does not change from its initial state after turning power ON.

Initial display of the central remote control

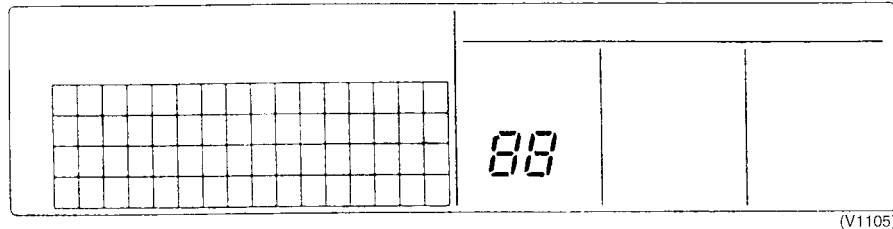
**Cause**

1. None of the indoor units connected to the central remote control have been given a group No.
2. The connector for setting the master controller inside the central remote control is disconnected.

Remedial Action

- Set a centralized control group No. for each indoor unit with the respective remote controls.
- Connect the connector for setting the master controller in one of the central remote control.

Main Points

- If the setting for master controller has been changed, reset the power to the unit at the ON/OFF switch or the forced reset switch of the controller.
- Activate power to the central remote control, unified ON/OFF controller and indoor unit before setting the centralized control group No.
- For details on how to set the centralized control group number, refer to the installation manual.

7.14.10 Malfunction "F6" is Displayed during Check Operation in the Winter Season.

Applicable Models RX(Y)(Q) ~ P (VRV III series)

Condition A malfunction "F6" (overcharge of refrigerant) is displayed when a "check operation" is executed as a test operation under the condition of low outdoor temperature in the winter season.

Cause Due to temporary refrigerant mixing into refrigerating oil, misjudgment is made when a "check operation" is executed under the condition of low outdoor temperature.

Measure The condition completes by executing the "check operation" again.

Point of Diagnosis Be sure to execute a "check operation" with the front panel closed. Or, misjudgment is made even if the outdoor temperature is low.

Conditions	Possible misjudgment
Low outdoor temperature	F6
High outdoor humidity	E3, E4. UF

7.14.11 LED Display for Master/slave Judgment Malfunctions at the Time of Test Operation.

Applicable Models

RX(Y)(Q) ~ P (Outdoor unit multi system of VRV III series)

Condition

LED display for master/slave judgment remained to be turned off the test operation of the multi system of two VRV III units though the unit being connected to the indoor-to-outdoor unit connection wire should be judged as a master unit normally.
At that time, the same LED for the slave unit of outdoor multi connection was blinking.

Cause

Instead of connection of "outdoor multi terminals (Q1 and Q2)", "outdoor-to-outdoor (F1 and F2)" connection was being applied at the time of multiple operation.

Measure

Recovers by correcting the wire connections between outdoor units to "outdoor multi (Q1 and Q2)".

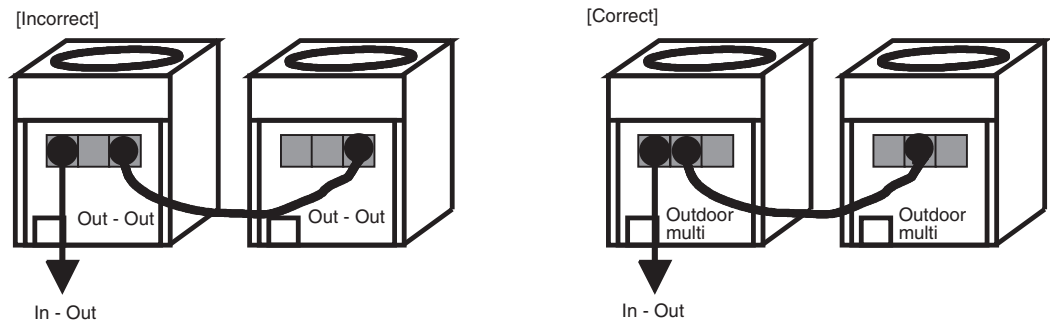
Point of Diagnosis

Select the method of connection of outdoor units from the following two methods, A and B.

- A. Batch connection between outdoor units of different systems → Connect the "Out - Out terminals (F1 and F2)".
- B. Multiple connection of the same system → Connect the "outdoor multiple terminals (Q1 and Q2)".

7.14.12 Cautions for Test Operation

Applicable Models	RX(Y)(Q) ~ P (VRV III series)
Condition	Though a test operation (check operation) in combination with the VRV III series outdoor unit had completed, a malfunction "E4 (abnormal low pressure malfunction)" or a malfunction "F3 (abnormal discharge pipe temperature malfunction)" occurred frequently after that.
Cause	Due to erroneous connection of wires and pipes, electronic expansion valve of the indoor unit does not open when only a single system is operated, which causes a faulty refrigerant circulation and results in a drop of pressure for low-pressure. Normal pressure is obtained by operating two systems simultaneously.
Measure	Issue a slip of request for modification work so that the erroneous connection of wires and pipes is corrected.
Point of Diagnosis	If a test operation (check operation) of multiple units of VRV III series is executed simultaneously, the test operation ends normally even if an erroneous connection exists. Be sure to execute a test operation (check operation) on an individual unit. Check whether there is an erroneous connection if a malfunction "E4" or a malfunction "F3" generates on the existing equipment.

7.14.13 Cautions for Demand Control with Externally Controlled Adapter

Applicable Models	RX(Y)(Q) ~ P (VRV III series)
Condition	Demand control with an externally control adapter attached to the VRV III series outdoor unit is desired. Thermostat does not turn off though C and 3 were short-circuited i.e., demand level 3, after setting. * Set items: Demand address 1 (Setting mode 2-2) Externally control ADP address 1 Demand setting change to ON from OFF (Setting mode 2-12)
Cause	Demand level setting (setting mode 2-30) remained to be the factory set value i.e., "70%". It should be changed the setting to "60%" to turn OFF the thermostat by the short circuit between C and 3.
Measure	The thermostat turns OFF by changing the setting mode 2-30 to "60%".
Point of Diagnosis	Change of mode setting is needed in accordance with the purpose of use. For setting methods, refer to the page 101 "4.4.2 Field setting from outdoor unit", of the section "4.4 Filed Settings from remote control".

7.14.14 Inferior Insulation of the Compressor before Test Operation

Applicable Models	VRV in general
Condition	At the time of test operation, compressor was replaced since the insulation was found insufficient in the insulation measurement with the power not supplied.
Cause	Insulation at the terminal section inside the compressor dropped temporarily due to non-operational condition of liquid refrigerant accumulated inside the compressor.
Measure	Resolved by supplying power to the crank case heater for 6 hours.
Point of Diagnosis	Measure the insulation resistance of the compressor after supplying power to the crank case heater for 6 hours.

7.14.15 No Heating Operation is Available though Cooling Operation is Possible. (Fan only Operation Continues with no Malfunction Displayed.)

Applicable Models	VRV in general
Condition	Compressor for one of two systems failed three times. Noise is heard on the compressor another system.
Cause	Erroneous connection of wires and pipes.
Measure	Recovers by correcting the connection.
Point of Diagnosis	<ol style="list-style-type: none"> 1. Operate a single indoor unit and check whether cold or hot air is obtained. 2. Operate also an another indoor unit. Then stop the 1st unit and check whether cold or hot blast is obtained. 3. Check the remaining units according to the above steps.



Note: Please note that, if an operation of another unit is initiated after stopping the 1st unit, the outdoor unit does not start for a while due to restart protection control.

7.14.16 Cooling Operation of Specific Indoor Units is not Good.

Applicable Models	VRV in general
Condition	<p>Cooling operation of specific indoor units only is not good though remaining indoor units work well and reach the set temperature.</p> <p>The pressure of the outdoor units for low-pressure use (evaporating temperature) has reached the target value.</p> <p>Liquid pipe temperature of the faulty indoor units is 4 to 5°C and gas pipe temperature is 18 to 22°C.</p>
Cause	Liquid pipe at the inlet of indoor unit was bent by hands and broken. It caused lacking in gas supply because essential refrigerant circulation amount was not secured for the indoor units.
Measure	Recovers by correcting the field piping.
Point of Diagnosis	<ol style="list-style-type: none"> 1. Check the following: Make sure that the difference between thermistor temperature of indoor unit's gas pipe and thermistor temperature of liquid pipe is approx. 5°C. <u>(Thermistor temperature of indoor unit's liquid pipe: 5 to 8°C; Thermistor temperature of gas pipe: 10 to 13°C)</u> 2. Check whether the pressure of outdoor unit for low-pressure (evaporating temperature) is approx. 0.4 MPa.

7.14.17 Malfunction Heating Due to Overcharge of Refrigerant

Applicable Models	VRV in general
Condition	Inverter compressor only operates at low frequency. Discharge temperature of the indoor units is 25°C or less and thermistor temperature of the liquid pipe is approx. 30°C when it is monitored through the service mode of the indoor remote control. The low-pressure at that time is around 0.2MPa.
Cause	Overcharged refrigerant. Due to overcharge, refrigerant accumulates in the indoor unit. Under this condition, temperature of the heat exchanger itself drops though the high-pressure rises. In addition, rise of high-pressure causes rise of liquid pressure that results in minimum opening of the electronic expansion valve of outdoor units leading to the wet operation. (The low-pressure at that time comes to be 0.2MPa due to minimum EV opening.)
Measure	Recovers by correcting the refrigerant to the specified amount.
Point of Diagnosis	<ol style="list-style-type: none"> 1. Use a manifold gauge to measure the high-pressure side of the outdoor unit and the pressure of service port of the liquid-side stop valve. Then check that the difference between the pressure on the high-pressure side and the pressure of the liquid pipe (intermediate pressure) is approx. 0.2MPa or more. (Approx. 0.2-MPa differential pressure is required to secure the flow rate at the electronic expansion valve.) 2. Check whether the subcooling of each indoor unit is normal. Difference between the saturation temperature being equivalent to the high-pressure and the thermistor temperature of liquid pipe of each indoor unit is approx. 5 to 8°C (Liquid pipe temperature is normally approx. 38°C or higher.)

7.14.18 High-pressure Shutdown Occurs only when the STD Compressor Starts.

Applicable Models	VRV in general
Condition	High-pressure rises abnormally and the high-pressure shutdown results when the STD compressor starts during cooling operation. (High-pressure tends to be higher even in the operation of inverter compressor only.) Temperature of heat exchanger thermistor of outdoor unit was found being equivalent to the outdoor temperature when data was collected by using the service checker type III.
Cause	Liquid-side stop valve was not fully open. (The staff considered it was fully open when inspected.)
Measure	Recovers by fully opening the stop valve.
Point of Diagnosis	Check whether the detecting temperature of heat exchanger thermistor is close to the saturation temperature being equivalent to the high-pressure. [Be sure to check all basic items like liquid-side stop valve and electronic expansion valve.]

7.15 Malfunction of Transmission Examples

7.15.1 [Malfunction of Transmission Examples]

Display of Malfunction of Transmission due to the Elevator's Power Line

Applicable Models	VRV in general
Condition	A malfunction "UE" is issued at random. It continues to be generated maximum 30 seconds. Transmitted waveforms were checked to be distorted for a period of approx. 10 seconds on site.
Cause	Out-Out transmission line had been laid next to the high-voltage line of the elevator.
Measure	Request to correct wiring.
Point of Diagnosis	

7.15.2 [Malfunction of Transmission Examples]

Malfunction of Transmission due to Wiring next to the High-voltage Line for Indoor Unit

Applicable Models	VRV in general
Condition	A malfunction "U4" sometimes occurred on the specific system. Its cause was not located though the transmission waveforms on the outdoor unit side were checked.
Cause	Waveforms on the indoor unit side were checked. The wiring on the indoor unit side had been laid next to the high-voltage line.
Measure	Keep the wiring of indoor unit away from the high voltage line.
Point of Diagnosis	

7.15.3 [Malfunction of Transmission Examples] Faulty Condition to Multi-core Wire

Applicable Models	VRV in general
Condition	
Cause	According to the wiring company, two-core lines were to be used as transmission line. However, multi-core lines are used actually. There was also a case where two cores out of four cores were being used for power supply.
Measure	Request to correct the wiring.
Point of Diagnosis	

7.15.4 [Malfunction of Transmission Examples] Faulty Condition Caused by the Use of Single-core Line

Applicable Models	VRV in general
Condition	
Cause	A malfunction "U4" is issued due to a single-core line used as a transmission line.
Measure	Changed to the VTCF two-core line.
Point of Diagnosis	

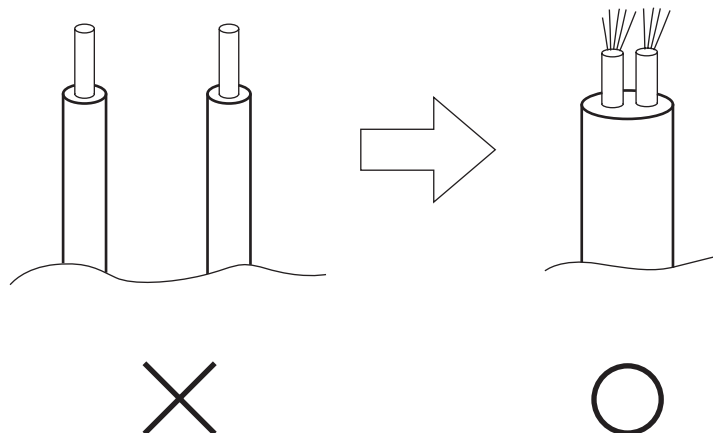

7.15.5 [Malfunction of Transmission Examples] Faulty Condition Caused by Branch Lines.

Applicable Models	VRV in general
Condition	A transmission malfunction occurred when the centralized controller was added to the existing system.
Cause	Ten of all indoor-to-outdoor lines were branch lines from a single bus cable.
Measure	Corrected IN - OUT wiring to one - after another wiring
Point of Diagnosis	

Part 2

Installation Manual

1. Heat Pump / Cooling Only 50Hz (RX(Y)Q5~54P).....	214
1.1 First of All	215
1.2 Introduction.....	218
1.3 Selection of Location	222
1.4 Inspecting and Handling the Unit	224
1.5 Placing the Unit	225
1.6 Refrigerant Piping.....	226
1.7 Field Wiring	237
1.8 Air Tight Test and Vacuum Drying	245
1.9 Pipe Insulation.....	247
1.10 Checking of Device and Installation Conditions	248
1.11 Additional Refrigerant Charge and Check Operation	249
1.12 Onsite Settings	256
1.13 Test Run.....	257
1.14 Caution for Refrigerant Leaks	258
2. Heat Pump 60Hz (RXYQ5~54P).....	260
2.1 First of All	261
2.2 Introduction.....	264
2.3 Selection of Location	268
2.4 Inspecting and Handling the Unit	270
2.5 Placing the Unit	271
2.6 Refrigerant Piping.....	272
2.7 Field Wiring	283
2.8 Air Tight Test and Vacuum Drying	291
2.9 Pipe Insulation.....	293
2.10 Checking of Device and Installation Conditions	294
2.11 Additional Refrigerant Charge and Check Operation	295
2.12 Onsite Settings	302
2.13 Test Run.....	303
2.14 Caution for Refrigerant Leaks	304

3. Heat Pump / Cooling Only 50Hz (RX(Y)Q5~54P)



INSTALLATION MANUAL

VRV III System air conditioner

RXYQ5PY1	RXQ5PY1
RXYQ8PY1	RXQ8PY1
RXYQ10PY1	RXQ10PY1
RXYQ12PY1	RXQ12PY1
RXYQ14PY1	RXQ14PY1
RXYQ16PY1	RXQ16PY1
RXYQ18PY1	RXQ18PY1
RXYQ20PY1	RXQ20PY1
RXYQ22PY1	RXQ22PY1
RXYQ24PY1	RXQ24PY1
RXYQ26PY1	RXQ26PY1
RXYQ28PY1	RXQ28PY1
RXYQ30PY1	RXQ30PY1
RXYQ32PY1	RXQ32PY1
RXYQ34PY1	RXQ34PY1
RXYQ36PY1	RXQ36PY1
RXYQ38PY1	RXQ38PY1
RXYQ40PY1	RXQ40PY1
RXYQ42PY1	RXQ42PY1
RXYQ44PY1	RXQ44PY1
RXYQ46PY1	RXQ46PY1
RXYQ48PY1	RXQ48PY1
RXYQ50PY1	RXQ50PY1
RXYQ52PY1	RXQ52PY1
RXYQ54PY1	RXQ54PY1

3.1 First of All

- This document is an installation manual for the Daikin RX(Y)Q-P Series VRV Inverter. Before installing the unit, read this manual thoroughly, and following the instructions contained in it. After installation, do a test run to make sure the unit runs properly, and then explain how to operate and take care of the unit to the customer, using the operation manual.
- Lastly, make sure the customer keeps this manual, along with the operation manual, in a safe place.
- This manual does not describe how to install the indoor unit. Refer to the installation manual included with the indoor unit for that.

3.1.1 Safety considerations

Please read these "Safety considerations" carefully before installing air conditioning unit and be sure to install it correctly. The safety precautions listed here are divided into two categories. In either case, important safety information is listed which must be read carefully.



Warning: Failure to observe a warning may result in death or serious injury.



Caution: Failure to observe a caution may result in injury or damage to the unit. These too might lead to serious injury depending on the circumstances.



- Warning:**
- Ask your dealer or qualified personnel to carry out installation work. Do not try to install the machine yourself.
Improper installation may result in water leakage, electric shocks or fire.
 - Perform installation work in accordance with this installation manual.
Improper installation may result in water leakage, electric shocks or fire.
 - When installing the unit in a small room, take measures against to keep refrigerant concentration from exceeding allowable safety limits in the event of refrigerant leakage. Contact your dealer for more information. Excessive refrigerant in a closed ambient can lead to oxygen deficiency.
 - Be sure to use only the specified accessories and parts for installation work.
Failure to use the specified parts may result in water leakage, electric shocks, fire or the unit falling.
 - Install the air conditioner on a foundation strong enough to withstand the weight of the unit.
A foundation of insufficient strength may result in the unit falling and causing injuries.
 - Carry out the specified installation work after taking into account strong winds, typhoons or earthquakes.
Improper installation work may result in the unit falling and causing accidents.
 - Make sure that a separate power supply circuit is provided for this unit and that all electrical work is carried out by qualified personnel according to local and national regulations and this installation manual.
An insufficient power supply capacity or improper electrical construction may lead to electric shocks or fire.
 - Make sure that all wiring is secured, the specified wires are used, and no external forces act on the terminal connections or wires.
Improper connections or installation may result in the terminals overheating or fire.
 - When wiring the power supply and connecting the remote control wiring and transmission wiring, position the wires so that the EL.COMPO.BOX lid can be securely fastened.
Improper positioning of the EL.COMPO.BOX lid may result in electric shocks or fire.
 - If the refrigerant gas leaks during installation, ventilate the area immediately.
Toxic gas may be produced if the refrigerant gas comes into contact with fire.
 - After completing the installation work, check that the refrigerant gas does not leak.
Toxic gas may be produced if the refrigerant gas leaks into the room and comes into contact with a source of fire, such as a fan heater, stove or cooker.
 - Do not directly touch the refrigerant leaked from refrigerant piping connections.
Frostbite may be caused.
 - Before touching electrical parts, turn off the power.

- Do not allow children to mount on the outdoor unit, or avoid placing any object on it. Falling or tumble may result in injury.
- Be sure to establish an earth.
Do not earth the unit to a utility pipe, arrester or telephone earth. 
Incomplete earth may cause electrical shock or fire.
A high surge current from lightning or other sources may cause damage to the air conditioner.
- Be sure to install an earth leakage breaker.
Failure to install an earth leakage breaker may result in electric shocks or fire.

**Caution:**

- While following the instructions in this installation manual, install drain piping in order to ensure proper drainage and insulate piping in order to prevent condensation. Improper drain piping may result in water leakage and property damage.
- Install the indoor and outdoor units, power supply wiring and connecting wiring at least 1 meter away from televisions or radios in order to prevent image interference or noise. (Depending on the radio waves, a distance of 1 meter may not be sufficient enough to eliminate the noise.)
- The indoor unit should be installed as far away from fluorescent lighting as possible. remote control (wireless kit) transmitting distance can result shorter than expected in rooms with electronic fluorescent lamps (inverter or rapid start types).
- Do not install the air conditioner in the following locations:
 - (a) where a mineral oil mist or an oil spray or vapor is produced, for example in a kitchen. Plastic parts may deteriorate and fall off or result in water leakage.
 - (b) where corrosive gas, such as sulfurous acid gas, is produced. Corroding copper pipes or soldered parts may result in refrigerant leakage.
 - (c) near machinery emitting electromagnetic waves. Electromagnetic waves may disturb the operation of the control system and result in a malfunction of the unit.
 - (d) where flammable gas may leak, where there are carbon fiber or ignitable dust suspensions in the air, or where volatile flammables such as thinner or gasoline are handled. Operating the unit in such conditions may result in fire.
 - (e) Locations where small animals might build nests inside the unit. If small animals enter and come in contact with electrical parts, this can cause malfunctions, smoke, and fire.

3.1.2 Special notice of product

[CLASSIFICATION]

This air conditioner comes under the term “appliances not accessible to the general public”.

[EMC CHARACTERISTICS]

VRVIII System is a class A product. In a domestic environment this product may cause radio interference in which case the user may be required to take adequate measures.

[REFRIGERANT]

VRVIII System use R-410A refrigerant.

- The refrigerant R-410A requires strict cautions for keeping the system clean, dry and tight. Read the chapter “REFRIGERANT PIPING” carefully and follow these procedures correctly.
 - A. Clean and dry
Foreign materials (including mineral oils such as SUNISO oil or moisture) should be prevented from getting mixed into the system.
 - B. Tight
Take care to keep the system tight when installing.
R-410A does not contain any chlorine, does not destroy the ozone layer, and does not reduce the earth’s protection against harmful ultraviolet radiation.
R-410A can contribute slightly to the greenhouse effect if it is released.
- Since R-410A is a mixed refrigerant, the required additional refrigerant must be charged in its liquid state. If the refrigerant is charged in a state of gas, its composition changes and the system will not work properly.

Limit by the total maximum refrigerant charge

The total maximum refrigerant charge of a VRVIII system must be below 100kg, this to be in accordance with CE requirement (EN60335-2-40 standard).

This means that in case the total maximum refrigerant charge of the system (factory and additional charge) is equal to or more than 100kg you must divide your multiple outdoor system into smaller independent systems, each containing less than 100kg refrigerant charge.

For factory charge, refer to the unit name plate.

[DESIGN PRESSURE]

Since design pressure is 4.0MPa or 40bar (for R-407C units: 3.3MPa or 33bar), the wall thickness of pipes should be more carefully selected in accordance with the relevant local and national regulations.

3.1.3 Disposal requirements

Dismantling of the unit, treatment of the refrigerant, oil and eventual other parts, should be done in accordance with the relevant local and national regulations.

3.2 Introduction

- RX(Y)Q-P series are designed for outdoor installation and used for cooling and heatpump (except RXQ-P) applications. Outdoor units come in three standard sizes, and with a single system through a multi system combining up to three outdoor units, rated cooling capacity from 14.0 kW to 147 kW and rated heating capacity from 16.0 kW to 170 kW (except RXQ-P) can be achieved.
- The RX(Y)Q-P units can be combined with Daikin VRV series indoor units for air conditioning purposes. Always use appropriate indoor units compatible with R-410A. To learn which models of indoor units are compatible with R-410A, refer to the product catalogs. To combine with other refrigerant indoor unit will cause malfunction.

3.2.1 Combination

The indoor units can be installed in the following range.

(The total number of indoor units cannot exceed 64 units.)

<Outdoor unit>	<Total capacity of indoor units>	<Total quantity of indoor units>
RX(Y)Q5PY1	62.5 ~ 250	12 units
RX(Y)Q8PY1	100 ~ 400	20 units
RX(Y)Q10PY1	125 ~ 500	25 units
RX(Y)Q12PY1	150 ~ 600	30 units
RX(Y)Q14PY1	175 ~ 700	35 units
RX(Y)Q16PY1	200 ~ 800	40 units
RX(Y)Q18PY1	225 ~ 900	45 units
RX(Y)Q20PY1	250 ~ 800	40 units
RX(Y)Q22PY1	275 ~ 880	44 units
RX(Y)Q24PY1	300 ~ 960	48 units
RX(Y)Q26PY1	325 ~ 1040	52 units
RX(Y)Q28PY1	350 ~ 1120	56 units
RX(Y)Q30PY1	375 ~ 1200	60 units
RX(Y)Q32PY1	400 ~ 1280	64 units
RX(Y)Q34PY1	425 ~ 1360	64 units
RX(Y)Q36PY1	450 ~ 1440	64 units
RX(Y)Q38PY1	475 ~ 1235	61 units
RX(Y)Q40PY1	500 ~ 1300	64 units
RX(Y)Q42PY1	525 ~ 1365	64 units
RX(Y)Q44PY1	550 ~ 1430	64 units
RX(Y)Q46PY1	575 ~ 1495	64 units
RX(Y)Q48PY1	600 ~ 1560	64 units
RX(Y)Q50PY1	625 ~ 1625	64 units
RX(Y)Q52PY1	650 ~ 1690	64 units
RX(Y)Q54PY1	675 ~ 1755	64 units



Note:

- Be sure to connect an R-410A indoor unit. See the catalog for indoor unit models which can be connected.
- At above is the total capacity and total number of units of the indoor units when configured in a standard combination. See the technical reference for details on total capacity and total number of indoor units when using a configuration other than the standard combination. The standard combination are as follows.

<Combination unit>

RXYQ5PY1
 RXYQ8PY1
 RXYQ10PY1
 RXYQ12PY1
 RXYQ14PY1
 RXYQ16PY1
 RXYQ18PY1
 RXYQ20PY1
 RXYQ22PY1
 RXYQ24PY1
 RXYQ26PY1
 RXYQ28PY1
 RXYQ30PY1
 RXYQ32PY1
 RXYQ34PY1
 RXYQ36PY1
 RXYQ38PY1
 RXYQ40PY1
 RXYQ42PY1
 RXYQ44PY1
 RXYQ46PY1
 RXYQ48PY1
 RXYQ50PY1
 RXYQ52PY1
 RXYQ54PY1

<Independent unit>

RXYQ5PY1
 RXYQ8PY1
 RXYQ10PY1
 RXYQ12PY1
 RXYQ14PY1
 RXYQ16PY1
 RXYQ18PY1
 RXYQ8PY1+ RXYQ12PY1
 RXYQ10PY1+ RXYQ12PY1
 RXYQ8PY1+ RXYQ16PY1
 RXYQ8PY1+ RXYQ18PY1
 RXYQ10PY1+ RXYQ18PY1
 RXYQ12PY1+ RXYQ18PY1
 RXYQ16PY1+ RXYQ16PY1
 RXYQ16PY1+ RXYQ18PY1
 RXYQ18PY1+ RXYQ18PY1
 RXYQ8PY1+ RXYQ12PY1 + RXYQ18PY1
 RXYQ8PY1+ RXYQ16PY1 + RXYQ16PY1
 RXYQ8PY1+ RXYQ16PY1+ RXYQ18PY1
 RXYQ8PY1+ RXYQ18PY1+ RXYQ18PY1
 RXYQ10PY1+ RXYQ18PY1+ RXYQ18PY1
 RXYQ12PY1+ RXYQ18PY1+ RXYQ18PY1
 RXYQ14PY1+ RXYQ18PY1+ RXYQ18PY1
 RXYQ16PY1+ RXYQ18PY1+ RXYQ18PY1
 RXYQ18PY1+ RXYQ18PY1+ RXYQ18PY1

<Combination unit>

RXQ5PY1
 RXQ8PY1
 RXQ10PY1
 RXQ12PY1
 RXQ14PY1
 RXQ16PY1
 RXQ18PY1
 RXQ20PY1
 RXQ22PY1
 RXQ24PY1
 RXQ26PY1
 RXQ28PY1
 RXQ30PY1
 RXQ32PY1
 RXQ34PY1
 RXQ36PY1
 RXQ38PY1
 RXQ40PY1
 RXQ42PY1
 RXQ44PY1
 RXQ46PY1
 RXQ48PY1
 RXQ50PY1
 RXQ52PY1
 RXQ54PY1

<Independent unit>

RXQ5PY1
 RXQ8PY1
 RXQ10PY1
 RXQ12PY1
 RXQ14PY1
 RXQ16PY1
 RXQ18PY1
 RXQ8PY1+ RXQ12PY1
 RXQ10PY1+ RXQ12PY1
 RXQ8PY1+ RXQ16PY1
 RXQ8PY1+ RXQ18PY1
 RXQ10PY1+ RXQ18PY1
 RXQ12PY1+ RXQ18PY1
 RXQ16PY1+ RXQ16PY1
 RXQ16PY1+ RXQ18PY1
 RXQ18PY1+ RXQ18PY1
 RXQ8PY1+ RXQ12PY1 + RXQ18PY1
 RXQ8PY1+ RXQ16PY1 + RXQ16PY1
 RXQ8PY1+ RXQ16PY1+ RXQ18PY1
 RXQ8PY1+ RXQ18PY1+ RXQ18PY1
 RXQ10PY1+ RXQ18PY1+ RXQ18PY1
 RXQ12PY1+ RXQ18PY1+ RXQ18PY1
 RXQ14PY1+ RXQ18PY1+ RXQ18PY1
 RXQ16PY1+ RXQ18PY1+ RXQ18PY1
 RXQ18PY1+ RXQ18PY1+ RXQ18PY1

- If the total capacity of the connected indoor units exceeds the capacity of the outdoor unit, cooling and heating performance may drop when running the indoor units. See the capacity table in the Engineering Data Book for details.
- There are restrictions on the refrigerant pipe connecting order between outdoor unit in the case of the multi system.

Install so that the following restrictions are satisfied.

<Restrictions>



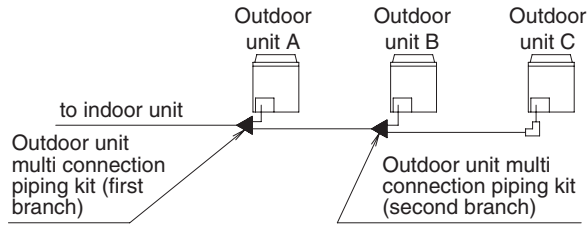

The capacities of outdoor units A, B and C must fulfill the following conditions.





$$A \geq B \geq C$$



3.2.2 Standard supplied accessories

The following accessories are included. The storage location of the accessories is shown in figure 1.

Q5~Q18 type				
Name	Clamp (1)	Clamp (2)	Clamp (3)	Gas side accessory pipe (1)
Quantity	9 pcs.	2 pcs.	1 pc.	1 pc.
Shape	 Small		 Large	

Q5~Q18 type				
Name	Gas side accessory pipe (2)	Liquid side accessory pipe (1)	Liquid side accessory pipe (2)	Others
Quantity	1 pc.	1 pc.	1 pc.	<ul style="list-style-type: none"> ■ Operation manual ■ Installation manual ■ "REQUEST FOR THE INDICATION" label (Installation records)
Shape	 5-10 HP type  12-18 HP type		 5-10, 14, 16 HP type  12, 18 HP type	

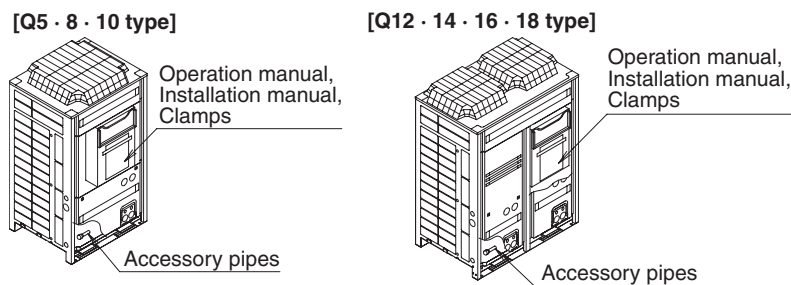

figure 1

i Note: Do not throw away any of the accessories until installation is complete.

3.2.3 Option accessory

To install the outdoor units, the following optional parts are also required. To select an optimum kit, refer to “6. Refrigerant Piping”.

■ Refrigerant branching kit

REFNET header	KHRP26M22H	KHRP26M33H	KHRP26M72H	KHRP26M73H
REFNET joint	KHRP26A22T	KHRP26A33T	KHRP26A72T	KHRP26A73T

■ Outdoor unit multi connection piping kit

Number of outdoor units connected	2 units	3 units
Kit name	BHFP22P100	BHFP22P151

■ Pipe size reducer

Kit name	KHRP26M73TP	KHRP26M73HP
----------	-------------	-------------



Note: Make sure that any separately purchased accessories are designed for use with R-410A.

3.2.4 Technical and Electrical specifications

Refer to the Engineering Data Book for the complete list of specifications.

3.2.5 Main components

For main components and function of the main components, refer to the Engineering Data Book.

3.2.6 Installation Process

Figure 2 shows the installation process. Install in the order of the steps shown.

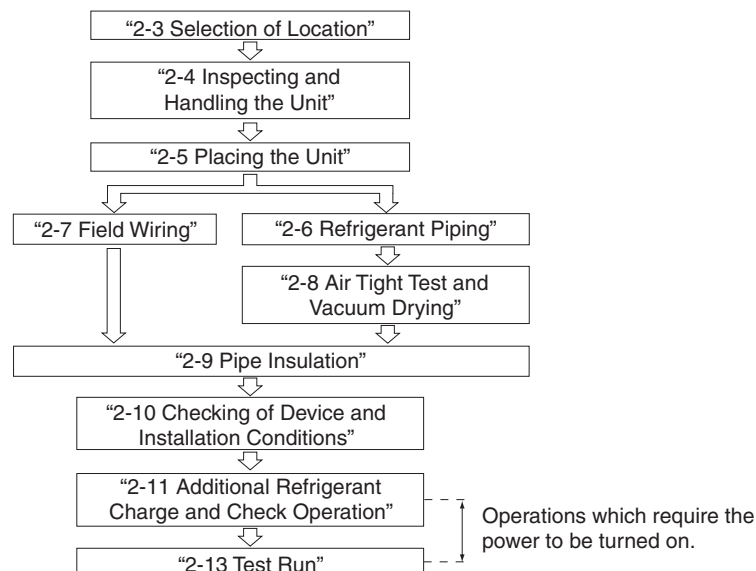

figure 2

3.3 Selection of Location

Select a location for installation that meets the following conditions. Get the customer's permission.

1. There is no danger of fire due to leakage of inflammable gas.
2. Select the location of the unit in such a way that neither the discharged air nor the sound generated by the unit disturb anyone.
3. The foundation is strong enough to support the weight of the unit and the floor is flat to prevent vibration and noise generation.
4. The piping length between the outdoor unit and the indoor unit may not exceed the allowable piping length. (Refer to "1-6 Refrigerant Piping")
5. Locations where the unit's suction vent and outlet vent do not generally face the wind. Wind blowing directly into the suction or outlet vents will interfere with the unit's operation. If necessary, install some kind of obstruction to block the wind.
6. The space around the unit is adequate for servicing and the minimum space for air inlet and air outlet is available.

(See the "Installation Space Examples" for the minimum space requirements.)

Installation Space Examples

- The installation space requirement shown in figure 3 is a reference for cooling operation when the outdoor temperature is 35°C.
If the design outdoor temperature exceeds 35°C or the heat load exceeds maximum capacity in all the outdoor unit, take an even large space on the intake shown in figure 3.
- During installation, install the units using the most appropriate of the patterns shown in figure 3 for the location in question, taking into consideration human traffic and wind.
- If the number of units installed is more than that shown in the pattern in figure 3, install the units so there are no short circuits.
- As regards space in front of the unit, consider the space needed for the local refrigerant piping when installing the units.
- If the work conditions in figure 3 do not apply, contact your dealer or Daikin directly.

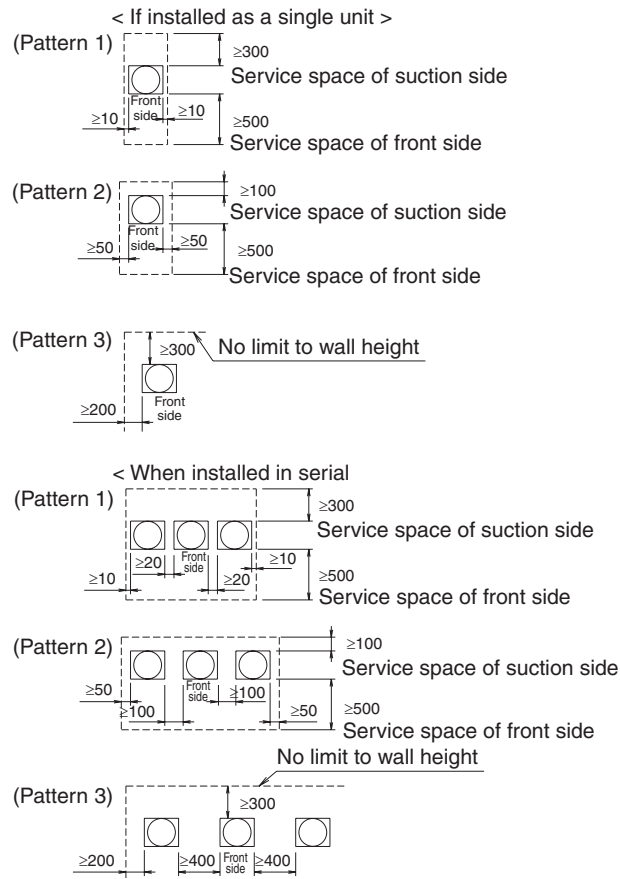
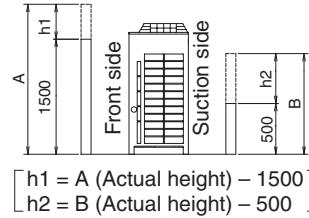

figure 3

For Patterns 1 and 2 in figure 3:

- Wall height for front side no higher than 1500 mm.
- Wall height on the suction side no higher than 500 mm.
- Wall height for sides – no limit.
- If the height is exceeded the above, calculate h1 and h2 shown in the figure below, and add h1/2 to the service space of front side and h2/2 to the service space of suction side.

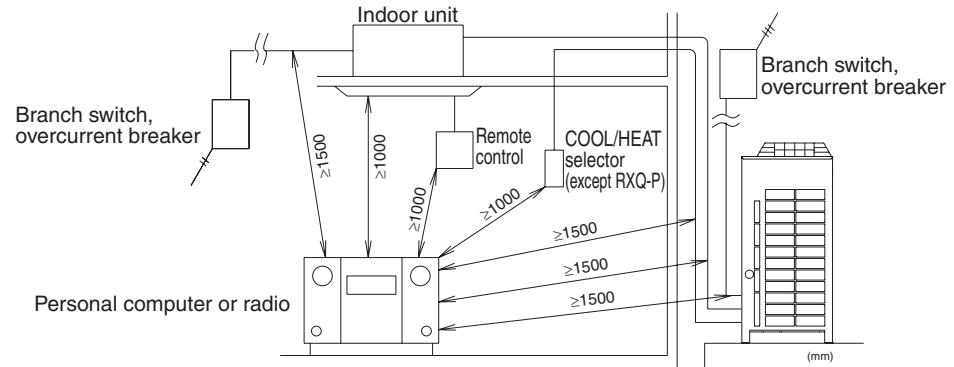

**Note:**

1. An inverter air conditioner may cause electronic noise generated from AM broadcasting. Examine where to install the main air conditioner and electric wires, keeping proper distances away from stereo equipment, personal computers, etc. Particularly for locations with weak reception, ensure there is a distance of at least 3 meters for indoor remote controls, place power wiring and transmission wiring in conduits, and ground the conduits.

**figure 4**

2. When installing in a locations where there is heavy snowfall, implement the following snow measures.
 - Ensure the base is high enough that intakes are not clogged by snow.
 - Remove the rear intake grille to prevent snow from accumulating on the fins.
3. If condensate may drip on downstairs (or walkway) depending on the floor condition, take a measure such as the installation of central drain pan kit (sold separately).
4. The refrigerant R-410A itself is nontoxic, nonflammable and is safe. If the refrigerant should leak however, its concentration may exceed the allowable limit depending on room size. Due to this it could be necessary to take measures against leakage. See “1-14 Caution for Refrigerant Leaks” for details.

3.4 Inspecting and Handling the Unit

- At delivery, the package should be checked and any damage should be reported immediately to the carrier claims agent.
- When handling the unit, take into account the following:
 1.  Fragile, handle the unit with care.
 2.  Keep the unit upright in order to avoid compressor damage.
 2. Decide on the transportation route.
 3. If a forklift is to be used, pass the forklift arms through the large openings on the bottom of the unit. **(Refer to figure 5)**
 4. If hanging the unit, use a cloth sling to prevent damaging the unit. Keeping the following points in mind, hang the unit following the procedure shown in figure 6.
 - Use a sling sufficiently strong to hold the mass of the unit.
 - Use 2 belts of at least 8m long.
 - Place extra cloth or boards in the locations where the casing comes in contact with the sling to prevent damage.
 - Hoist the unit making sure it is being lifted at its center of gravity.
 5. After installation, remove the transportation clasp attached to the large openings. **(Refer to figure 6)**

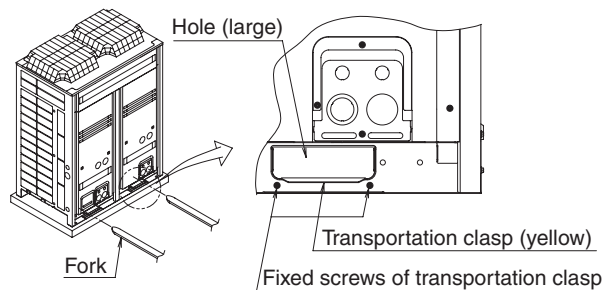

figure 5

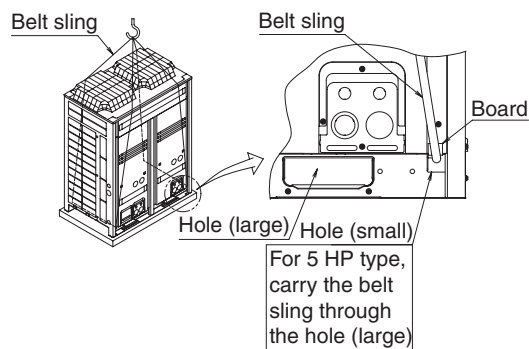

figure 6

3.5 Placing the Unit

- Make sure the unit is installed level on a sufficiently strong base to prevent vibration and noise. (Refer to figure 7)
- The base should be bigger around than the width of the unit's legs (66 mm), and should support the unit. (Refer to figure 8)
If protective rubber is to be attached, attach it to the whole face of the base.
- The height of the base should be at least 150mm from the floor.
- Secure the unit to its base using foundation bolts. (Use four commercially available M12-type foundation bolts, nuts, and washers.)
- The foundation bolts should be inserted 20 mm.

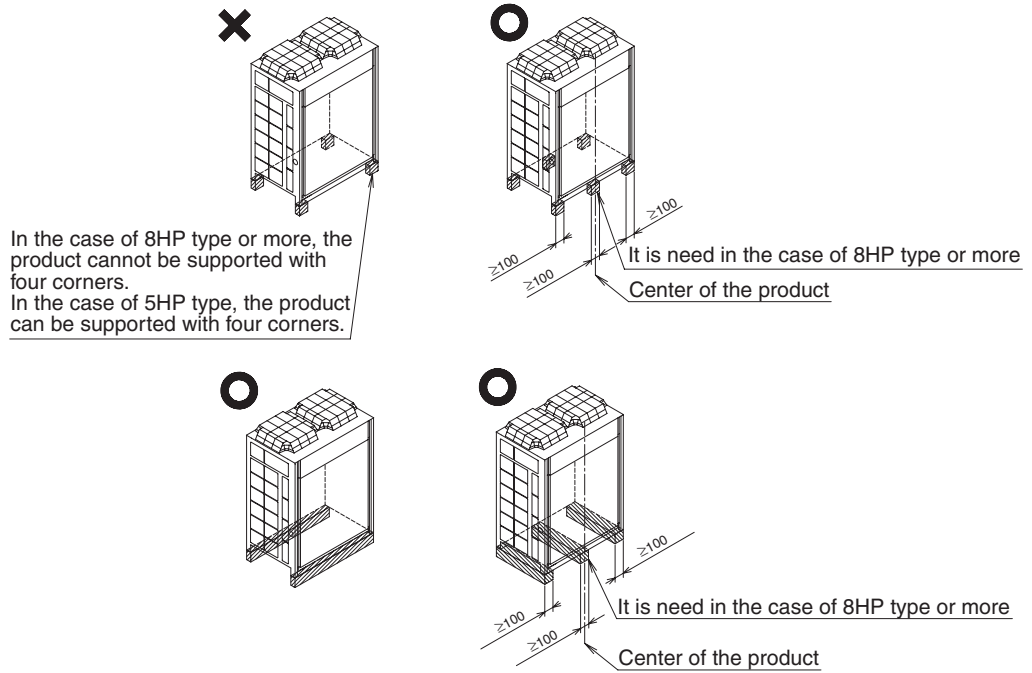
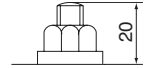

figure 7

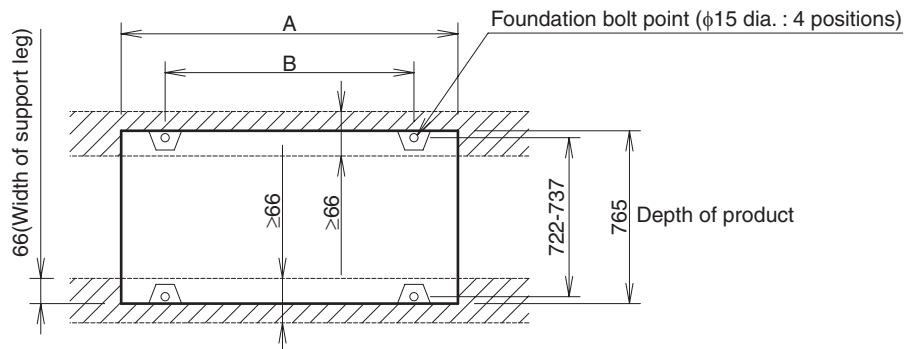

figure 8

Model	A	B
5HP type	635	497
8 · 10HP type	930	792
12 · 14 · 16 · 18HP type	1240	1102



Note:

- There are restrictions on the refrigerant pipe connecting order between outdoor unit in the case of the multi system.
See the Note in “1-2-1 Combination” for detail.
- When installing on a roof, make sure the roof floor is strong enough and be sure to waterproof all work.
- Make sure the area around the machine drains properly by setting up drainage grooves around the foundation.
Drain water is sometimes discharged from the outdoor unit when it is running.

3.6 Refrigerant Piping



- Note:**
- All field piping must be installed by a licensed refrigeration technician and must comply with relevant local and national regulations.
 - After piping work is complete, do not under any circumstances open the shutoff valve until “1-7 Field Wiring” and “1-10 Checking of Device and Installation Conditions” are complete.
 - Do not use flux when brazing the refrigerant piping. Use the phosphor copper brazing filler metal (BCuP-2: JIS Z 3264/B-Cu93P-710/795: ISO 3677) which does not require flux. (Flux has extremely harmful influence on refrigerant piping systems. For instance, if the chlorine based flux is used, it will cause pipe corrosion or, in particular, if the flux contains fluorine, it will damage the refrigerant oil.)

3.6.1 Selection of piping material and Refrigerant branching kit

- Use only pipes which are clean inside and outside and which do not accumulate harmful sulfur, oxidants, dirt, cutting oils, moisture, or other contamination. (Foreign materials inside pipes including oils for fabrication must be 30mg/10m or less.)
- Use the following items for the refrigerant piping.

Material: Jointless phosphor-deoxidized copper pipe

Size: See “1-6-5 Example of connection” to determine the correct size.

Thickness: Select a thickness for the refrigerant piping which complies with national and local laws.

For R-410A, the design pressure is 4.0 MPa (40-bar).

The minimum thickness of piping according to Japan’s High-Pressure Gas Safety Law (as of January 2003) is shown below.

Temper grade (O type, 1/2H type) in the table indicate the material types specified in JIS H 3300.

(unit: mm)

Temper grade	O type			
outer diameter	φ6.4	φ9.5	φ12.7	φ15.9
smallest thickness	0.80	0.80	0.80	0.99

(unit: mm)

Temper grade	1/2H type							
outer diameter	φ19.1	φ22.2	φ25.4	φ28.6	φ31.8	φ34.9	φ38.1	φ41.3
smallest thickness	0.80	0.80	0.88	0.99	1.10	1.21	1.32	1.43

- For piping work, follow the maximum tolerated length, difference in height, and length after a branch indicated in the “1-6-5 Example of connection”.
- A refrigerant branching kit (sold separately) is needed for piping branches and connection of piping between outdoor unit (in case of multi system).
Use only separately sold items selected specifically according to the refrigerant branch kit selection in the “1-6-5 Example of connection”.

3.6.2 Protection against contamination when installing pipes

Protect the piping to prevent moisture, dirt, dust, etc. from entering the piping.

Place	Installation period	Protection method
Outdoor	More than a month	Pinch the pipe
	Less than a month	Pinch or tape the pipe
Indoor	Regardless of the period	



- Note:** Exercise special caution to prevent dirt or dust when passing piping through holes in walls and when passing pipe edges to the exterior.

3.6.3 Pipe connection

- Be sure to perform nitrogen permutation or nitrogen blow when brazing. (Refer to figure 10) Brazing without performing nitrogen permutation or nitrogen blow into the piping will create large quantities of oxidized film on the inside of the pipes, adversely affecting valves and compressors in the refrigerating system and preventing normal operation.

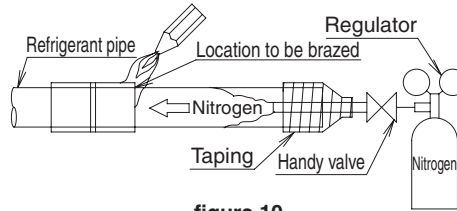

figure 10

- The pressure regulator for the nitrogen released when doing the brazing should be set to 0.02 MPa (about 0.2kg/cm²:Enough to feel a slight breeze on your cheek).



Note: Do not use anti-oxidants when brazing the pipe joints. Residue can clog pipes and break equipment.

3.6.4 Connecting the refrigerant piping

- Direction to bring out the pipes
The local interunit piping can be connected either forward or to the sides (taken out through the bottom) as shown in the figure 11.
(When passing out through the bottom, use the knock hole in the bottom frame.)

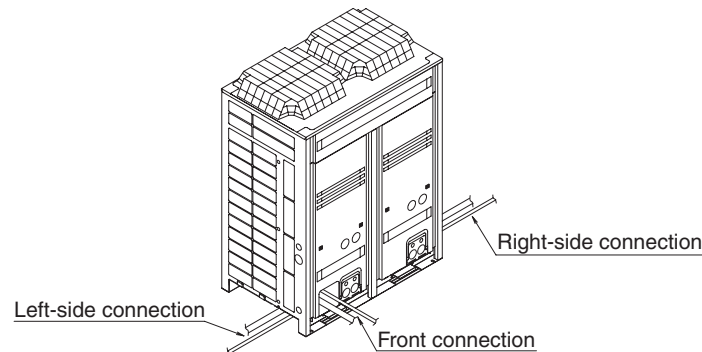
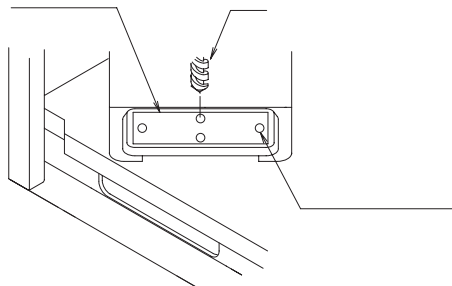

figure 11

Precautions when knocking out knock holes

- Open knock hole in the base frame by drilling the 4 concave around it with a 6mm bit. (Refer to figure 12)



- Be sure to avoid damaging the casing
- After knocking out the holes, we recommend you remove any burrs and paint them using the repair paint to prevent rusting.
- When passing electrical wiring through the knock holes, protect the wiring with a conduit or bushings, making sure not to damage the wiring.

2. Removing Pinch Piping

- When connecting refrigerant piping to an outdoor unit, remove the pinch piping. (Refer to figure 13)
- Pinch piping should be removed using the procedure in the figure 13.

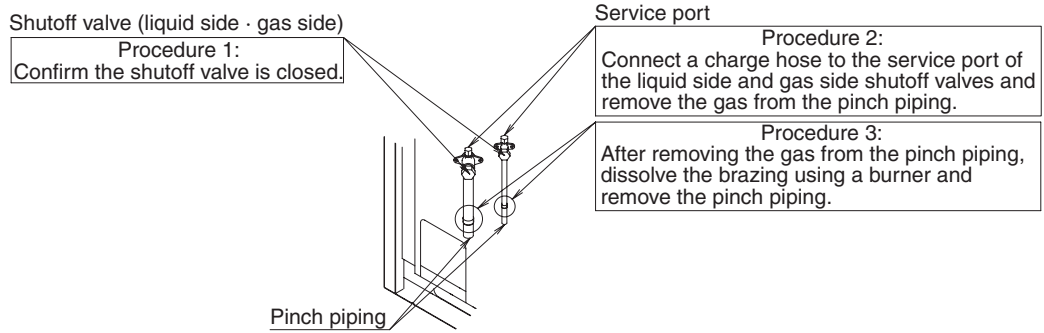

figure 13



Caution: After removing the gas, remove the pinch piping. Any gas remaining inside may blow off the pinch piping when you dissolve the brazing, causing damage.

3. Connecting refrigerant piping to outdoor units

<In case of single system: 5-18HP type>

If connected to the front

Remove the shutoff valve cover to connect.

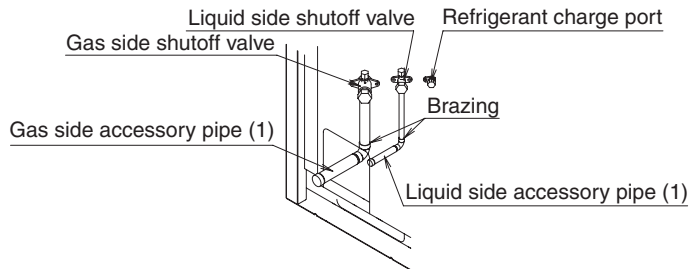

When connected at lateral side (bottom)

Remove the knock hole on the bottom frame and route the piping under the bottom frame.

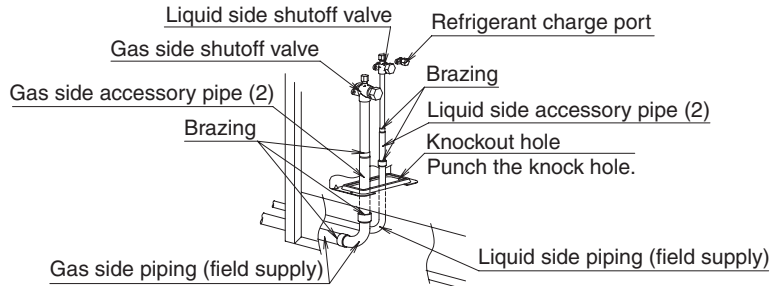
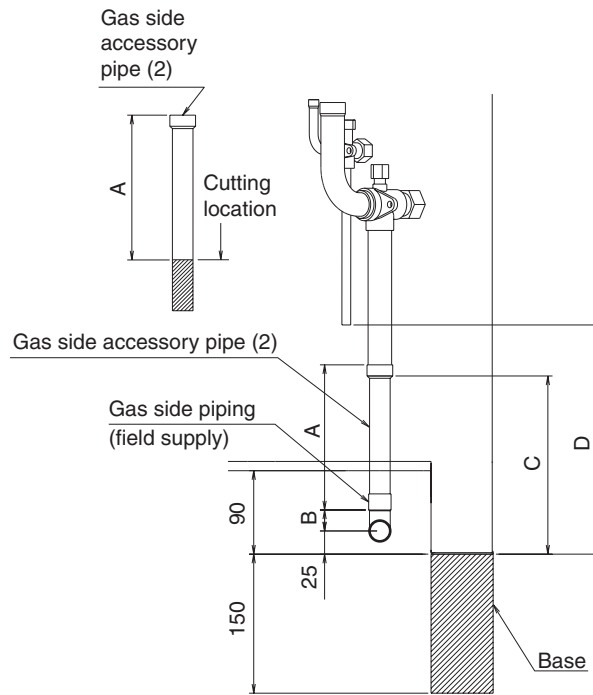

figure 14

Processing the Gas side accessory pipe (2)

Only in case of connecting at lateral side, cut the Gas side accessory pipe (2) referring the figure below.



(mm)

Model	A	B	C	D
5HP type	166	16	199	246
8HP type	156	17	188	247
10HP type	156	23	192	247
12HP type	150	29	192	247
14·16·18HP type	150	29	192	251

<In case of multi system: RX(Y)Q20-54P>

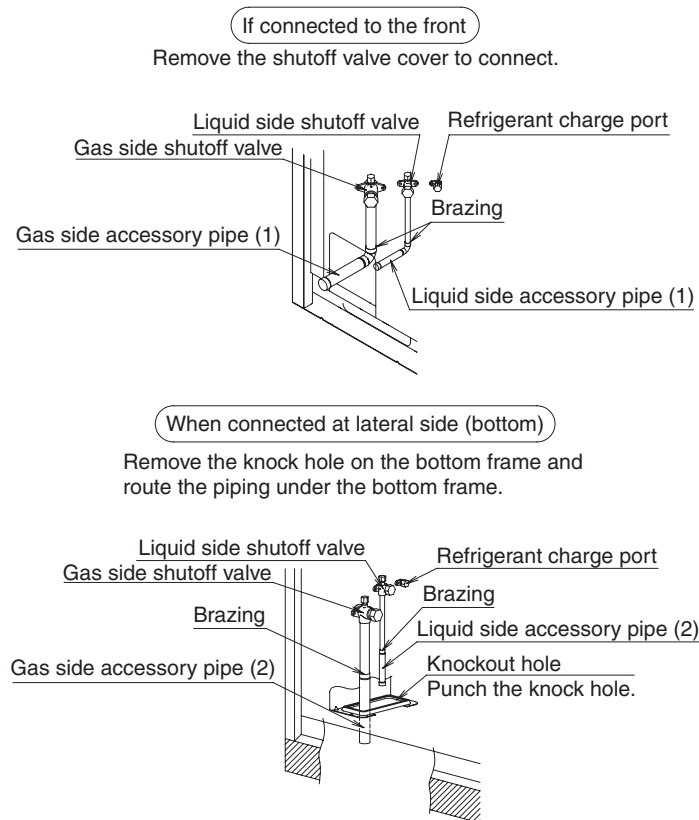

figure 15

**Note: <Connecting Refrigerant Piping>**

- When connecting the piping on site, be sure to use the accessory piping.
- Make sure the onsite piping does not come into contact with other piping or the bottom frame or side panels of the unit.

<Multi Systems>

- The 5HP type cannot be used as an independent unit in a multi system.
- The Outdoor unit multi connection piping kit (sold separately) is needed when connecting piping between outdoor units.

Refer to the installation manual that comes with the kit when doing this piping work.

4. Precautions when connecting piping between outdoor units (In case of multi system)
 The Outdoor unit multi connection piping kit (sold separately) is needed to connect piping between outdoor units in multi system. Only proceed with piping work after considering the limitations on installation listed here and in “5. Branching the refrigerant piping”, always referring to the kit’s installation manual.

(1) The piping between outdoor units must be installed level (Pattern 1) or with a rise (Pattern 2). Otherwise oil may pool in the pipes.

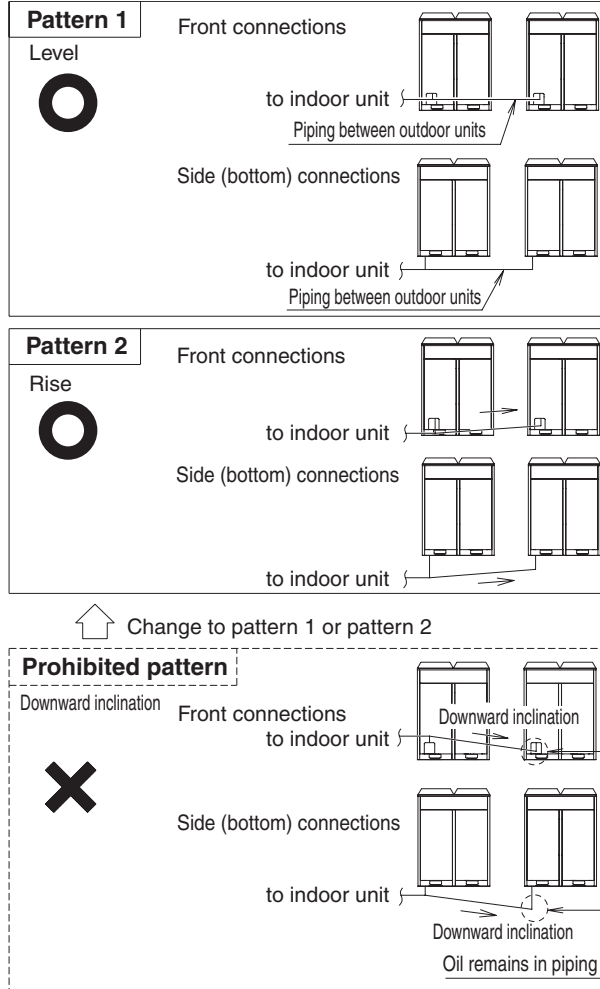

(2) To avoid the risk of oil detention in the stopping unit, always connect the shutoff valve and the piping between outdoor units as shown in the figure A or figure B.

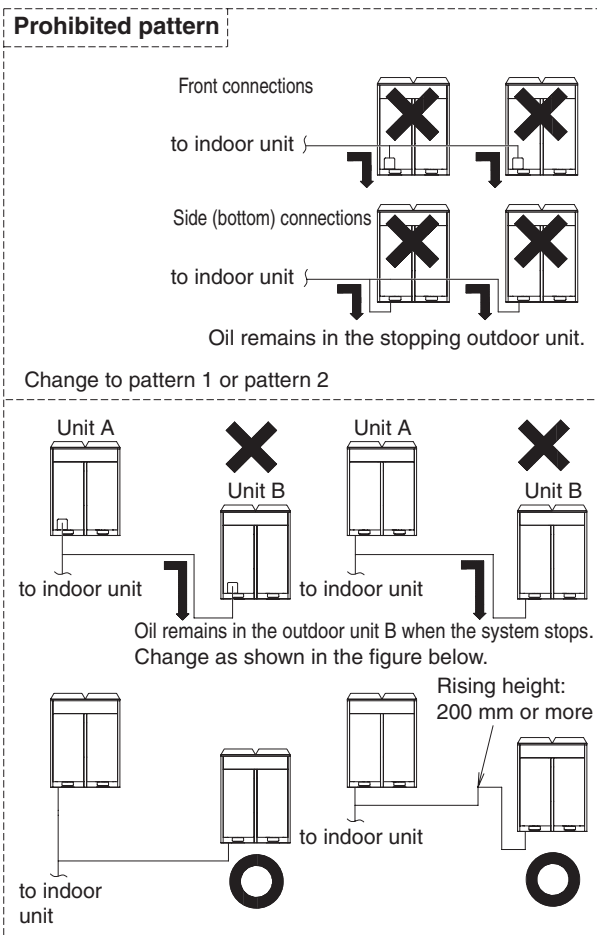
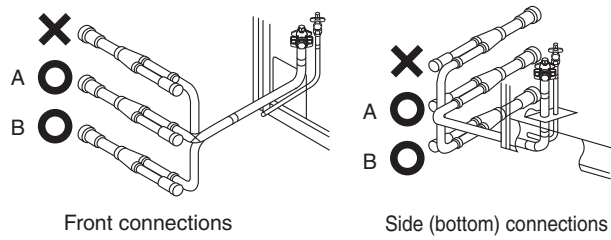

(3) If the piping length between the outdoor units exceeds 2 m, create a rise of 200 mm or more in the gas line under a length of 2 m from the outdoor unit multi connection piping kit.

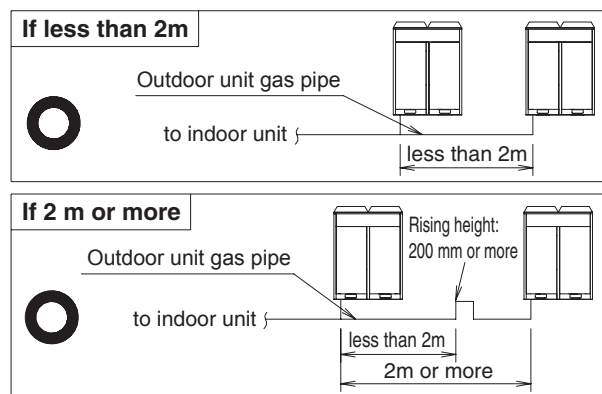

5. Branching the refrigerant piping

Heed the restrictions below when installing the refrigerant branching kit and read the installation instruction manual with the kit.
(Improper installation could lead to malfunctioning or breakdown of the outdoor unit.)

<REFNET joint>

Install the REFNET joint so it splits horizontally or vertically.

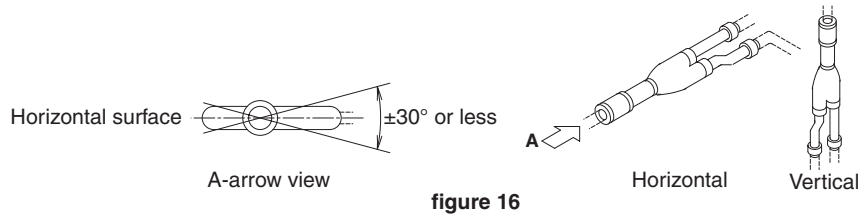

figure 16

<REFNET header>

Install the REFNET header so it splits horizontally.



figure 17

<Outdoor unit multi connection piping kit>

- Install the joint horizontally so that the attached warning label faces straight up, and the tilt is within $\pm 15^\circ$. (Refer to figure 18-1)
Do not install vertically. (Refer to figure 18-2)
- Maintain a straight portion of 500 mm or more until the split of the joint without wrapping any onsite piping around this area.
Over 500 mm of straight area can be maintained by connecting at least 120 mm of onsite pipe (straight) to the joint. (Refer to figure 18-3)

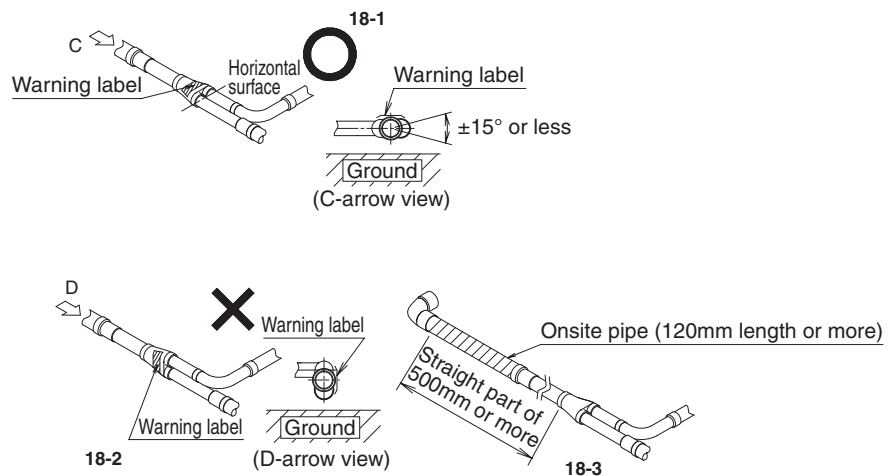
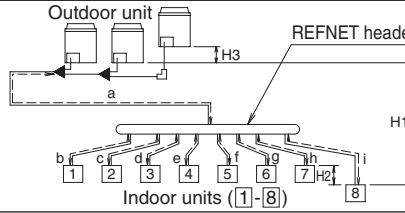
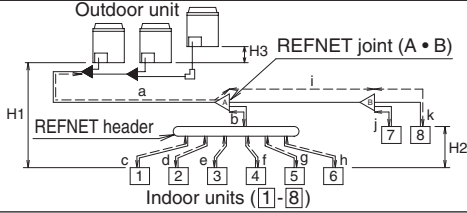
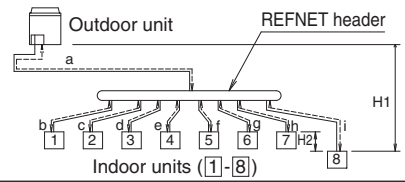
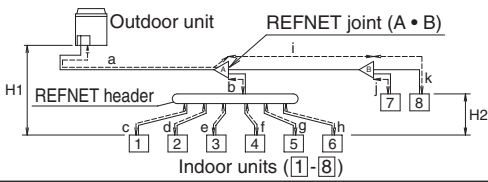

figure 18

3.6.5 EXAMPLE OF CONNECTION

Example of connection (Connection of 8 indoor units) (*1) " ← " indicate the Outdoor unit multi connection piping kit (*2) In case of multi outdoor system, re-read to the first Outdoor unit multi connection piping kit as seen from the indoor unit.		Single outdoor system		Example																													
		Multi outdoor system		Example																													
Maximum allowable length	Between outdoor (*2) and indoor units	Actual pipe length	Pipe length between outdoor (*2) and indoor units ≤ 165m Example unit [8] : a + b + c + d + e + f + g + p ≤ 165m	Example																													
		Equivalent length	Equivalent pipe length between outdoor (*2) and indoor units ≤ 190m (assume equivalent length)	Example																													
		Total extension length	Total pipe length from outdoor unit (*2) to all indoor units ≤ 1000m	Example																													
Allowable height length	Between outdoor unit and Outdoor unit multi connection piping kit (Only for multi system)	Actual pipe length Equivalent length	Pipe length between outdoor unit and Outdoor unit multi connection piping kit ≤ 10m, Eq	Example																													
	Between outdoor and indoor units	Difference in height	Difference in height between outdoor and indoor units (H1) ≤ 50m (≤ 90m if the outdoor unit is multi outdoor system)	Example																													
	Between indoor and indoor units	Difference in height	Difference in height between indoor units (H2) ≤ 15m	Example																													
Allowable length after the branch	Between outdoor and outdoor units	Difference in height	Difference in height between outdoor unit (H3) ≤ 5m	Example																													
	Actual pipe length	Actual pipe length	Pipe length from first refrigerant branch kit (either REFNET joint or REFNET header) to indoor units (1-8) Example unit [8] : b + c + d + e + f + g + p ≤ 40m	Example																													
Refrigerant branch kit selection Refrigerant branch kits can only be used with R-410A. ⚠ When multi outdoor system are installed, be sure to use the special separately sold Outdoor unit multi connection piping kit. The table at right shows how to select the proper kit.		How to select the REFNET joint • When using REFNET joint at the first branch counted from the outdoor unit side. Choose from the following table in accordance with the outdoor unit capacity type. (Example: REFNET joint A) <table border="1"> <thead> <tr> <th>Outdoor unit capacity type</th> <th>Refrigerant branch kit</th> </tr> </thead> <tbody> <tr> <td>5HP type</td> <td>KHRP26A22T</td> </tr> <tr> <td>8, 10HP type</td> <td>KHRP26A33T</td> </tr> <tr> <td>12~22HP type</td> <td>KHRP26A72T</td> </tr> <tr> <td>24HP type~</td> <td>KHRP26A73T + KHRP26A72T</td> </tr> </tbody> </table> • Choose the REFNET joints other than that for the first branch from the following table in accordance with the capacity index of all the indoor units connected below the REFNET joint. <table border="1"> <thead> <tr> <th>Indoor unit total capacity index</th> <th>Refrigerant branch kit</th> </tr> </thead> <tbody> <tr> <td>< 200</td> <td>KHRP26A22T</td> </tr> <tr> <td>200 ≤ x < 290</td> <td>KHRP26A33T</td> </tr> <tr> <td>290 ≤ x < 640</td> <td>KHRP26A72T</td> </tr> <tr> <td>640 ≤</td> <td>KHRP26A73T + KHRP26A72T</td> </tr> </tbody> </table>			Outdoor unit capacity type	Refrigerant branch kit	5HP type	KHRP26A22T	8, 10HP type	KHRP26A33T	12~22HP type	KHRP26A72T	24HP type~	KHRP26A73T + KHRP26A72T	Indoor unit total capacity index	Refrigerant branch kit	< 200	KHRP26A22T	200 ≤ x < 290	KHRP26A33T	290 ≤ x < 640	KHRP26A72T	640 ≤	KHRP26A73T + KHRP26A72T									
Outdoor unit capacity type	Refrigerant branch kit																																
5HP type	KHRP26A22T																																
8, 10HP type	KHRP26A33T																																
12~22HP type	KHRP26A72T																																
24HP type~	KHRP26A73T + KHRP26A72T																																
Indoor unit total capacity index	Refrigerant branch kit																																
< 200	KHRP26A22T																																
200 ≤ x < 290	KHRP26A33T																																
290 ≤ x < 640	KHRP26A72T																																
640 ≤	KHRP26A73T + KHRP26A72T																																
Example for indoor units connected downstream		Example REFNET joint C: indoor units [3]+[4]+[5]+[6]+[7]+[8]																															
Pipe size selection ⚠ Caution The thickness of the pipes in the table shows the requirements of Japanese High Pressure Gas Control law. (As of Jan. 2003) The thickness and material shall be selected in accordance with local code. For the multi outdoor unit system, select in accordance with the following figure.		Temper grade and wall thickness for pipes. (Temper grade, O type and 1/2H type indicate the material types specified in JIS H 3300.) (Unit:mm) <table border="1"> <thead> <tr> <th>Copper tube O.D.</th> <th>Copper tube W.T. (Minimum requirement)</th> <th>Temper grade</th> </tr> </thead> <tbody> <tr><td>φ6.4</td><td>0.80</td><td rowspan="4">O type</td></tr> <tr><td>φ9.5</td><td>0.80</td></tr> <tr><td>φ12.7</td><td>0.80</td></tr> <tr><td>φ15.9</td><td>0.99</td></tr> <tr><td>φ19.1</td><td>0.80</td><td rowspan="7">1/2H type</td></tr> <tr><td>φ22.2</td><td>0.80</td></tr> <tr><td>φ25.4</td><td>0.88</td></tr> <tr><td>φ28.6</td><td>0.99</td></tr> <tr><td>φ31.8</td><td>1.10</td></tr> <tr><td>φ34.9</td><td>1.21</td></tr> <tr><td>φ38.1</td><td>1.32</td></tr> <tr><td>φ41.3</td><td>1.43</td></tr> </tbody> </table>			Copper tube O.D.	Copper tube W.T. (Minimum requirement)	Temper grade	φ6.4	0.80	O type	φ9.5	0.80	φ12.7	0.80	φ15.9	0.99	φ19.1	0.80	1/2H type	φ22.2	0.80	φ25.4	0.88	φ28.6	0.99	φ31.8	1.10	φ34.9	1.21	φ38.1	1.32	φ41.3	1.43
Copper tube O.D.	Copper tube W.T. (Minimum requirement)	Temper grade																															
φ6.4	0.80	O type																															
φ9.5	0.80																																
φ12.7	0.80																																
φ15.9	0.99																																
φ19.1	0.80	1/2H type																															
φ22.2	0.80																																
φ25.4	0.88																																
φ28.6	0.99																																
φ31.8	1.10																																
φ34.9	1.21																																
φ38.1	1.32																																
φ41.3	1.43																																
How to calculate the additional refrigerant to be charged Additional refrigerant to be charged R (kg) (R should be rounded off in units of 0.1Kg.)		$R = \left(\frac{\text{Total length (m) of liquid piping size at } \phi 22.2}{\text{Total length (m) of liquid piping size at } \phi 19.1} \right) \times 0.37 + \left(\frac{\text{Total length (m) of liquid piping size at } \phi 19.1}{\text{Total length (m) of liquid piping size at } \phi 15.9} \right) \times 0.26 + \left(\frac{\text{Total length (m) of liquid piping size at } \phi 15.9}{\text{Total length (m) of liquid piping size at } \phi 6.4} \right) \times 0.18 + \left(\frac{\text{Total length (m) of liquid piping size at } \phi 6.4}{\text{Total length (m) of liquid piping size at } \phi 6.4} \right) \times 0.022$																															

Example refrigerant branch using REFNET joint and REFNET header **Example refrigerant branch using REFNET header**



Example unit 6 : a + b + h ≤ 165m, unit 8 : a + i + k ≤ 165m Example unit 8 : a + i ≤ 165m

(Assume equivalent pipe length of REFNET joint to be 0.5m, that of REFNET header to be 1m, calculation purposes) (See Note 1 - Next page)

Vertical distance between outdoor unit and indoor unit ≤ 10m, Equivalent length between outdoor unit and Outdoor unit multi connection piping kit ≤ 13m

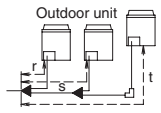

r ≤ 10m (Equivalent length: ≤ 13m)
s ≤ 10m (Equivalent length: ≤ 13m)
t ≤ 10m (Equivalent length: ≤ 13m)

Vertical distance between REFNET header and indoor unit ≤ 40m (See Note 2 - Next page)

Example unit 6 : b + h ≤ 40m, unit 8 : i + k ≤ 40m Example unit 8 : i ≤ 40m

Outdoor unit capacity type.

Refrigerant branch kit name
HP26A22T
HP26A33T
HP26A72T
HP26A73T + KHRP26M73TP

How to select the REFNET header

- Choose from the following table in accordance with the total capacity index of all the indoor units connected below the REFNET header.
- Note: 250 type indoor unit cannot be connected below the REFNET header.

Indoor unit total capacity index	Refrigerant branch kit name
< 200	KHRP26M22H (Max. 4 branch)
200 ≤ x < 290	KHRP26M33H (Max. 8 branch)
290 ≤ x < 640	KHRP26M72H (Max. 8 branch) (See Note 3 - Next page)
640 ≤	KHRP26M73H (Max. 8 branch) + KHRP26M73HP

Following table in accordance with the total capacity type.

Refrigerant branch kit name
HP26A22T
HP26A33T
HP26A72T
HP26A73T + KHRP26M73TP

How to select the Outdoor unit multi connection piping kit (This is required when the system is multi outdoor unit system.)

- Choose from the following table in accordance with the number of outdoor units.

Number of outdoor units	Connection piping kit name
2 units	BHFP22P100
3 units	BHFP22P151

Example REFNET joint B: indoor units 7+8
Example REFNET header: indoor units 1+2+3+4+5+6

Example REFNET header: indoor units 1+2+3+4+5+6+7+8

Piping between Outdoor unit and first refrigerant branch kit.
Piping between first Outdoor unit multi connection piping kit and first refrigerant branch kit. (Part A)

- Choose from the following table in accordance with the outdoor unit capacity type.

Piping between Outdoor unit multi connection piping kits. (Part B)
Piping between outdoor unit and Outdoor unit multi connection piping kit. (Part C)

- Choose from the following table in accordance with the total capacity type of all the outdoor units connected above Outdoor unit multi connection piping kit. (Unit:mm)

Outdoor unit capacity type	Piping size (O.D.)	
	Gas pipe	Liquid pipe
5HP type	φ15.9	φ9.5
8HP type	φ19.1	
10HP type	φ22.2	
12~16HP type	φ28.6	φ12.7
18~22HP type		φ15.9
24HP type	φ34.9	φ19.1
26~34HP type	φ41.3	
36~54HP type		

(See Note 1 - Next page)

Piping between refrigerant branch kits

- Choose from the following table in accordance with the total capacity index of all the indoor units connected below this.
- Do not let the connection piping exceed the main refrigerant piping size. (Unit:mm)

Indoor unit total capacity index	Piping size (O.D.)	
	Gas pipe	Liquid pipe
< 150	φ15.9	φ9.5
150 ≤ x < 200	φ19.1	
200 ≤ x < 290	φ22.2	
290 ≤ x < 420	φ28.6	φ12.7
420 ≤ x < 640		φ15.9
640 ≤ x < 920	φ34.9	φ19.1
920 ≤	φ41.3	

Piping between refrigerant branch kit and indoor unit

- Match to the size of the connection piping on the indoor unit. (Unit:mm)

Indoor unit capacity type	Piping size (O.D.)	
	Gas pipe	Liquid pipe
20 · 25 · 32 · 40? · 50 type	φ12.7	φ9.5
63 · 80 · 100 · 125 type	φ15.9	
200 type	φ19.1	
250 type	φ22.2	

$$\left(\frac{\text{Total length (m) of gas piping}}{\text{size at } \phi 9.5} \right) \times 0.18 + \left(\frac{\text{Total length (m) of liquid piping}}{\text{size at } \phi 12.7} \right) \times 0.12 + \left(\frac{\text{Total length (m) of liquid piping}}{\text{size at } \phi 9.5} \right) \times 0.059$$

Example for refrigerant branch using REFNET joint and REFNET header

In case the outdoor unit is RXYQ34 type and the piping lengths are as at right

a: φ19.1 × 30m	d: φ9.5 × 10m	g: φ 6.4 × 10m	j: φ 6.4 × 10m
b: φ15.9 × 10m	e: φ9.5 × 10m	h: φ 6.4 × 20m	k: φ 6.4 × 9m
c: φ 9.5 × 10m	f: φ9.5 × 10m	i: φ12.7 × 10m	

$$R = \frac{30 \times 0.26}{\uparrow} + \frac{10 \times 0.18}{\uparrow} + \frac{10 \times 0.12}{\uparrow} + \frac{40 \times 0.059}{\uparrow} + \frac{49 \times 0.022}{\uparrow} = 14.238 \downarrow$$

14.2 kg

3.6.6 EXAMPLE OF CONNECTION)

*Note 1

When the equivalent pipe length between outdoor and indoor units is 90m or more, the size of main pipe Depending on the length of the piping, the capacity may drop, but even in such case it is able to increa

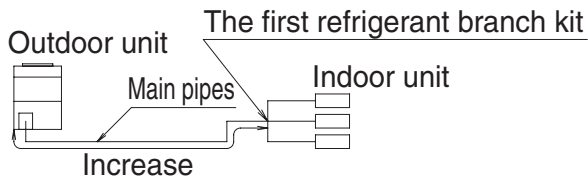

figure 9

■ Diameter of above case

Model	Gas	Liquid
RX(Y)Q5 Type	φ19.1	Not Increased
RX(Y)Q8 Type	φ22.2	φ12.7
RX(Y)Q10 Type	φ25.4*	φ12.7
RX(Y)Q12 Type	Not Increased	φ15.9
RX(Y)Q14 Type	Not Increased	φ15.9
RX(Y)Q16 Type	φ31.8*	φ15.9
RX(Y)Q18 Type	φ31.8*	φ19.1

Model	Gas	Liquid
RX(Y)Q20 Type	φ31.8*	φ19.1
RX(Y)Q22 Type	φ31.8*	φ19.1
RX(Y)Q24 Type	Not Increased	φ19.1
RX(Y)Q26 Type	φ38.1*	φ22.2
RX(Y)Q28 Type	φ38.1*	φ22.2
RX(Y)Q30 Type	φ38.1*	φ22.2
RX(Y)Q32 Type	φ38.1*	φ22.2

*Note 2

Allowable length after the first refrigerant branch kit to indoor units is 40 m or less, however it can be extend

Required Conditions	Example Drawings
1. It is necessary to increase the pipe size between the first branch kit and the final branch kit. (Reducers must be procured on site) However, the pipes that are same pipe size with main pipe must not be increased.	[8] $b+c+d+e+f+g+p \leq 90$ m increase the pipe size of b, c, d, e, f
2. For calculation of Total extension length, the actual length of above pipes must be doubled. (except main pipe and the pipes that are not increased)	$a+b \times 2+c \times 2+d \times 2+e \times 2+f \times 2+g \times 2+h+i+j+k+l+m+n+p \leq 1000$ m
3. Indoor unit to the nearest branch kit ≤ 40 m	h, i, j,..... p ≤ 40 m
4. The difference between [Outdoor unit to the farthest indoor unit] and [Outdoor unit to the nearest indoor unit] ≤ 40 m	The farthest indoor unit [8] The nearest indoor unit [1] $(a+b+c+d+e+f+g+p) - (a+h) \leq 40$ m

*If available on the site, use this size. Otherwise it can not be increased.

*Note 3

If the pipe size above the REFNET header is φ34.9 or more, KHRP26M73HP is required.

in pipes (both gas-side and liquid-side) must be increased.
crease the size of main pipes.

Model	Gas	Liquid
RX(Y)Q34 Type	φ38.1*	φ22.2
RX(Y)Q36 Type	Not Increased	φ22.2
RX(Y)Q38 Type	Not Increased	φ22.2
RX(Y)Q40 Type	Not Increased	φ22.2
RX(Y)Q42 Type	Not Increased	φ22.2
RX(Y)Q44 Type	Not Increased	φ22.2
RX(Y)Q46 Type	Not Increased	φ22.2

Model	Gas	Liquid
RX(Y)Q48 Type	Not Increased	φ22.2
RX(Y)Q50 Type	Not Increased	φ22.2
RX(Y)Q52 Type	Not Increased	φ22.2
RX(Y)Q54 Type	Not Increased	φ22.2

*If available on the site, use this size.
Otherwise, it can not be increased.

extended up to **90 m** if all the following conditions are satisfied. (In case of “ **Branch with REFNET joint** ”)

ings	
n , e, f, g	Increase the pipe size as follows $\phi 9.5 \rightarrow \phi 12.7$ $\phi 15.9 \rightarrow \phi 19.1$ $\phi 22.2 \rightarrow \phi 25.4^*$ $\phi 34.9 \rightarrow \phi 38.1^*$ $\phi 12.7 \rightarrow \phi 15.9$ $\phi 19.1 \rightarrow \phi 22.2$ $\phi 28.6 \rightarrow \phi 31.8^*$
:2+g×2) m	<p>Outdoor unit</p> <p>REFNET joint (A-G)</p> <p>Indoor units (1 - 8)</p>
γ) ≤ 40 m	

1.7 Field Wiring



- Caution:**
- All field wiring and components must be installed by a licensed electrician and must comply with relevant local and national regulations.
 - Be sure to use a dedicated power circuit. Never use a power supply shared by another appliance.
 - Never install a phase advancing capacitor. As this unit is equipped with an inverter, installing a phase advancing capacitor will not only deteriorate power factor improvement effect, but also may cause capacitor abnormal heating accident due to high-frequency waves.
 - Only proceed with wiring work after blocking off all power.
 - Always ground wires in accordance with relevant local and national regulations.
 - This machine includes an inverter device. Connect earth and leave charge to eliminate the impact on other devices by reducing noise generated from the inverter device and to prevent leaked current from being charged in the outer hull of the product.
 - Do not connect the ground wire to gas pipes, sewage pipes, lightning rods, or telephone ground wires.
 - Gas pipes:** can explode or catch fire if there is a gas leak.
 - Sewage pipes:** no grounding effect is possible if hard plastic piping is used.
 - Telephone ground wires and lightning rods:** dangerous when struck by lightning due to abnormal rise in electrical potential in the grounding.
 - Be sure to install an earth leakage circuit breaker.
 - This unit uses an inverter, so install the earth leakage circuit breaker that be capable of handling high harmonics in order to prevent malfunctioning of the earth leakage circuit breaker itself.
 - Earth leakage circuit breaker which are especially for protecting ground-faults should be used in conjunction with main switch or fuse for use with wiring.



- Note:**
- Electrical wiring must be done in accordance with the wiring diagrams and the description herein.
 - Do not operate until refrigerant piping work is completed.
(If operated before complete the piping work, the compressor may be broken down.)
 - Never remove thermistor, sensor or etc. when connecting power wiring and transmission wiring.
(If operated with thermistor, sensor or etc. removed, the compressor may be broken down.)
 - This product have reversed phase protection detector that only works when the power is turned on. If there exists black out or the power goes on and off which the product is operating, attach a reversed phase protection circuit locally. Running the product in reversed phase may break the compressor and other parts.
 - Attach the power wire securely. Introducing power with a missing N-phase or with a mistaken N-phase will break the unit.
 - Never connect the power supply in reversed phase.
The unit can not operate normally in reversed phase.
If you connect in reversed phase, replace two of the three phases.
 - Make sure the electrical unbalance ratio is no greater than 2%. If it is larger than this, the unit's life span will be reduced.
If the ratio exceeds 4%, the unit will shut down and an malfunction code will be displayed on the indoor remote control.
 - Connect the wire securely using designated wire and fix it with attached clamp without applying external pressure on the terminal parts (terminal for power wiring, terminal for transmission wiring and earth terminal).

1.7.1 Power circuit, safety device, and cable requirements

- A power circuit (see the following table) must be provided for connection of the unit. This circuit must be protected with the required safety devices, i.e. a main switch, a slow blow fuse on each phase and an earth leakage circuit breaker.
- When using residual current operated circuit breakers, be sure to use a high-speed type (1 second or less) 200mA rated residual operating current.
- Use copper conductors only.
- Use insulated wire for the power cord.
- Select the power supply cable type and size in accordance with relevant local and national regulations.
- Specifications for local wiring are in compliance with IEC60245.
- Use wire type H05VV when protected pipes are used.
Use wire type H07RN-F when protected pipes are not used.

	Phase and frequency	Voltage	Minimum circuit amp.	Recommended fuses
RX(Y)Q5PY1	φ 3, 50Hz	380-415V	11.9A	15A
RX(Y)Q8PY1	φ 3, 50Hz	380-415V	18.5A	25A
RX(Y)Q10PY1	φ 3, 50Hz	380-415V	21.6A	25A
RX(Y)Q12PY1	φ 3, 50Hz	380-415V	22.7A	25A
RX(Y)Q14PY1	φ 3, 50Hz	380-415V	31.5A	35A
RX(Y)Q16PY1	φ 3, 50Hz	380-415V	31.5A	35A
RX(Y)Q18PY1	φ 3, 50Hz	380-415V	32.5A	40A
RX(Y)Q20PY1	φ 3, 50Hz	380-415V	41.2A	50A
RX(Y)Q22PY1	φ 3, 50Hz	380-415V	44.3A	50A
RX(Y)Q24PY1	φ 3, 50Hz	380-415V	50.0A	60A
RX(Y)Q26PY1	φ 3, 50Hz	380-415V	51.0A	60A
RX(Y)Q28PY1	φ 3, 50Hz	380-415V	54.1A	60A
RX(Y)Q30PY1	φ 3, 50Hz	380-415V	55.2A	70A
RX(Y)Q32PY1	φ 3, 50Hz	380-415V	63.0A	70A
RX(Y)Q34PY1	φ 3, 50Hz	380-415V	64.0A	80A
RX(Y)Q36PY1	φ 3, 50Hz	380-415V	65.0A	80A
RX(Y)Q38PY1	φ 3, 50Hz	380-415V	73.7A	90A
RX(Y)Q40PY1	φ 3, 50Hz	380-415V	81.5A	90A
RX(Y)Q42PY1	φ 3, 50Hz	380-415V	82.5A	100A
RX(Y)Q44PY1	φ 3, 50Hz	380-415V	83.5A	100A
RX(Y)Q46PY1	φ 3, 50Hz	380-415V	86.6A	100A
RX(Y)Q48PY1	φ 3, 50Hz	380-415V	87.7A	100A
RX(Y)Q50PY1	φ 3, 50Hz	380-415V	96.5A	110A
RX(Y)Q52PY1	φ 3, 50Hz	380-415V	96.5A	110A
RX(Y)Q54PY1	φ 3, 50Hz	380-415V	97.5A	110A



Note: The above table indicates power specifications for standard combinations (see 1-2 Introduction).

If using anything other than the above combinations in a multi system, calculate using the following procedure.

Minimum circuit amp value: add the minimum circuit amp values for each independent unit

Recommended fuse capacity: select the fuse capacity with the next higher value of the calculated minimum circuit amp. multiplied by 1.1.

Ex: Combining the RXYQ30PY1 using RXYQ8PY1, RXYQ10PY1, and RXYQ12PY1.

Minimum circuit amp. of the RXYQ8PY1 in table above = 18.5 A

Minimum circuit amp. of RXYQ10PY1 in table above = 21.6 A

Minimum circuit amp. of RXYQ12PY1 in table above = 22.7 A

Accordingly, the minimum circuit amp. of the RXYQ30PY1 = 18.5 + 21.6 + 22.7= 62.8 A

Multiplying the result above by 1.1 (62.8 × 1.1) = 69.1 A, so the recommended fuse capacity would be 70 A.

1.7.2 Wiring Connection Example for Whole System

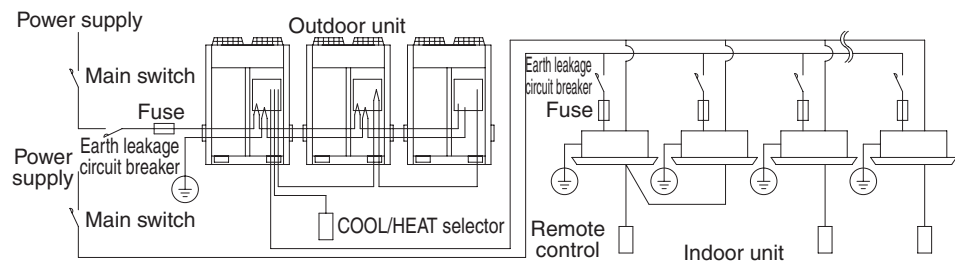

figure 19

- i Note:**
- Make sure the weak electric wiring (i.e. for the remote control, between units, etc.) and the power wiring do not pass near each other, keeping them at least 50 mm apart. Proximity may cause electrical interference, malfunctions, and breakage.
 - Be sure to connect the power wiring to the power wiring terminal block and secure it as described in “1-7-5 Power Wiring Connection Procedure”.
 - Transmission wiring should be secured as described in “1-7-4 Transmission Wiring Connection Procedure”.
 - Secure wiring with clamp such as insulation lock ties to avoid contact with piping.
 - Shape the wires to prevent the structure such as the EL. COMPO. BOX lid deforming. And close the cover firmly.
 - 5HP type can not compose multi system.

1.7.3 Leading wire Procedure

- The power wiring and ground wiring are passed out from the power wiring hole on the sides, the front (knock hole) or the bottom frame (knock hole) .
- The transmission wiring is passed out from the wiring hole (knock hole) on the front of the unit or from a piping hole.

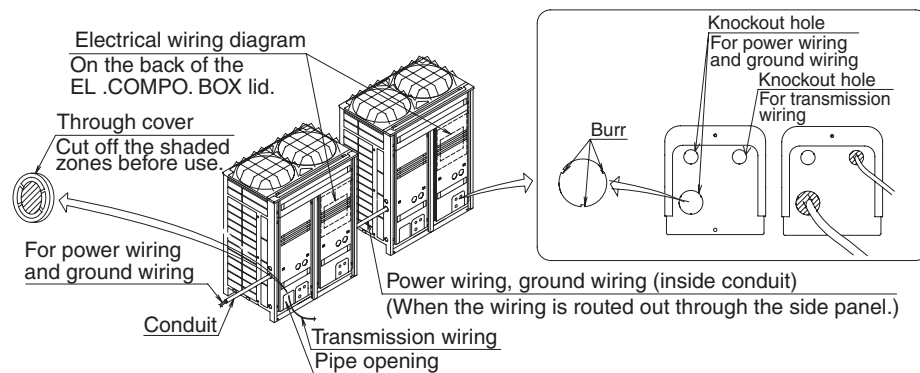

figure 20

- i Note:**
- Open the knock holes with a hammer or the like.
 - After knocking out the holes, we recommend you remove any burrs and paint them using the repair paint to prevent rusting.
 - When passing wiring through the knock holes, remove burrs around the knock holes and protect the wiring with protective tape. **(Refer to figure 20)**
 - If small animals might enter the unit, block off any gaps (hatching parts in figure 20) with material (field supply).

1.7.4 Transmission Wiring Connection Procedure

- Referring to figure 21, 22 connect the transmission wiring between outdoor unit and indoor unit, outdoor unit and outdoor unit of other system, outdoor unit and outdoor unit of same system (only multi system) or to COOL/HEAT selector (except RXQ-P).

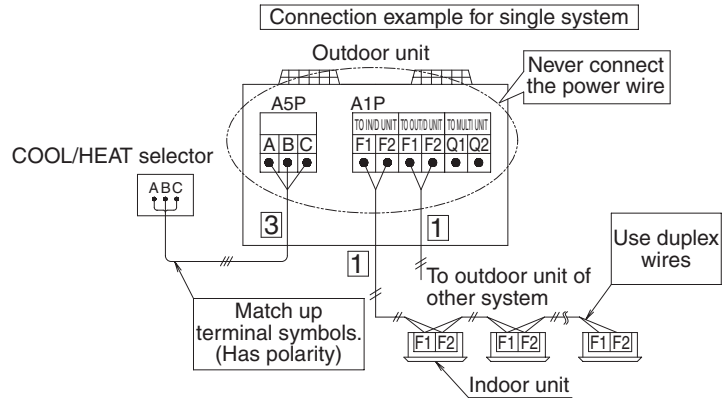

figure 21

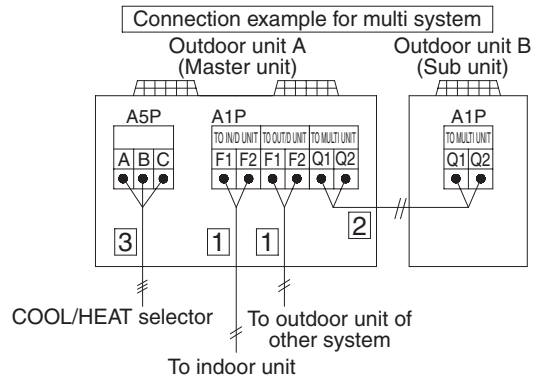

figure 22

- All transmission wiring is to be procured on site. All wiring should use sheathed vinyl cord 0.75-1.25 mm² or cable (duplex). (Triplex only for the COOL/HEAT selector.)
- Transmission wiring (About the symbol 1 ~ 3, see figure 21, 22) should be done within the following limitations.

If they are exceeded, transmission problems may occur.

1 Between outdoor unit and indoor unit

Between outdoor unit and outdoor unit of other systems

Max. wiring length	: 1,000 m
Max. total wiring length	: 2,000 m
Max. no. of branches	: 16

[Note]

No branch is allowed after branch (See figure 23)

Max. no. of outdoor units of other system

that can be connected : 10

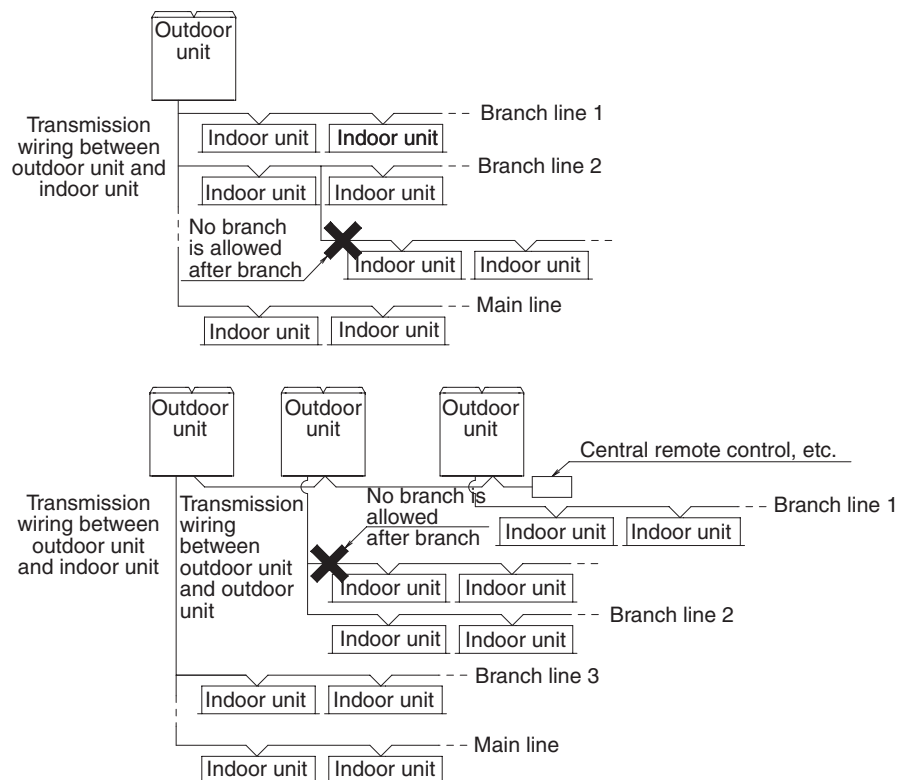

figure 23

- 2 Between outdoor unit and outdoor unit of same system (Only for multi system)

Max. wiring length	: 30 m
--------------------	--------
- 3 Transmission wiring to COOL/HEAT selector

Max. wiring length	: 500 m
--------------------	---------

- The transmission wiring inside the EL.COMPO.BOX should be secured using the clamp (1) as shown in figure 24.

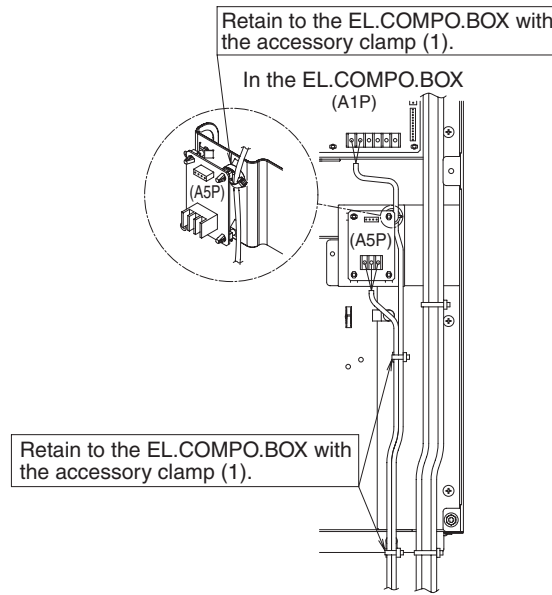

figure 24

- Outside the units, the transmission wiring must be finished simultaneously with the local refrigerant piping, and wound with tape (field supply) as shown in figure 25.

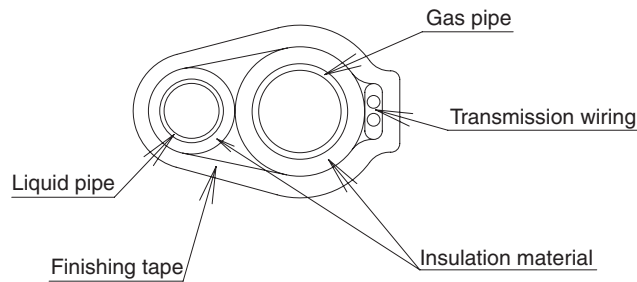

figure 25

- For multi system:
 1. Transmission wiring between outdoor units in the same piping system must be connected to terminals Q1 and Q2 (TO MULTI UNIT). Connecting the wires to the F1, F2 (TO OUT/D UNIT) terminals results in system malfunction.
 2. Wiring to other systems should be connected to terminals F1 and F2 (TO OUT/D UNIT) on the PC-board of the master unit. The outdoor unit that connected transmission wiring to indoor unit is the master unit. The others are sub unit.



Caution:

- Do not connect the power wiring to terminals for the transmission wiring. Doing so would destroy the entire system.
- When connecting wires to the terminal block on the PC-board, too much heat or tightening could damage the PC-board. Attach with care. See the table below for the tightening torque of the transmission wiring terminals.

Screw size	Tightening torque (N · m)
M3 (A5P)	0.53 - 0.63
M3.5 (A1P)	0.80 - 0.96

1.7.5 Power Wiring Connection Procedure

Be sure to connect the power supply wiring to the power supply terminal block and hold it in place using the included clamp as shown in the figure 26.

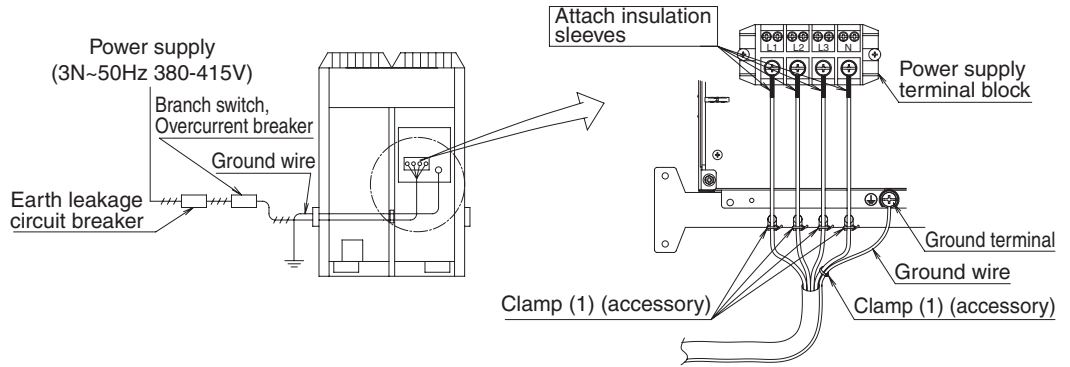

figure 26

- The L1, L2, L3 and N phases of the power wiring should be secured separately to the hook using the included clamp (1).
- The ground wiring should be bound to the power wiring using the included clamp (1) to prevent outside force from being applied to the terminal area.
- Wire so that the ground wiring does not come into contact with the compressor lead wiring. If they touch, this may have an adverse effect on other devices.



Caution:

- Be sure to use crimp-style terminal with insulating sleeves for connections. (See the figure below.)

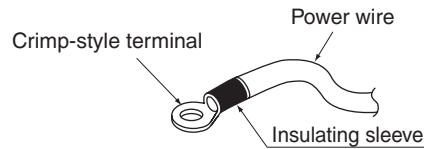

- For wiring, use the designated power wire and connect firmly, then secure to prevent outside pressure being exerted on the terminal board.
- Use an appropriate screwdriver for tightening the terminal screws. A screwdriver with a small head will strip the head and make proper tightening impossible.
- Over-tightening the terminal screws may break them.

See the following table for the tightening torque of the terminal screws.

Screw size	Tightening torque (N·m)
M8 Power terminal, ground terminal	5.5 ~7.3

- When pulling the ground wire out, wire it so that it comes through the cut out section of the cup washer. (See the figure below.) An improper ground connection may prevent a good ground from being achieved.

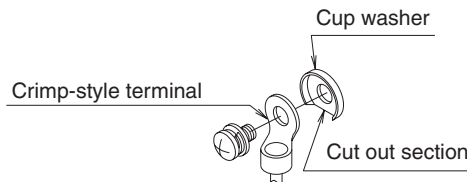

- When two wires are connected to a single terminal, connect them so that the rear sides of the crimp contacts face each other. Also, make sure the thinner wire is on top, securing the two wires simultaneously to the resin hook using the included clamp (1).

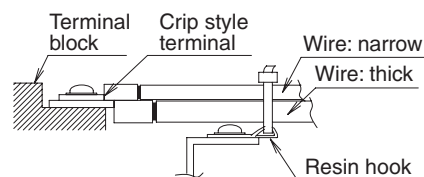

1.7.6 Procedure for Wiring Inside Units

- Referring to figure 27, secure and wire the power and transmission wiring using the included clamp (1), (2), and (3).

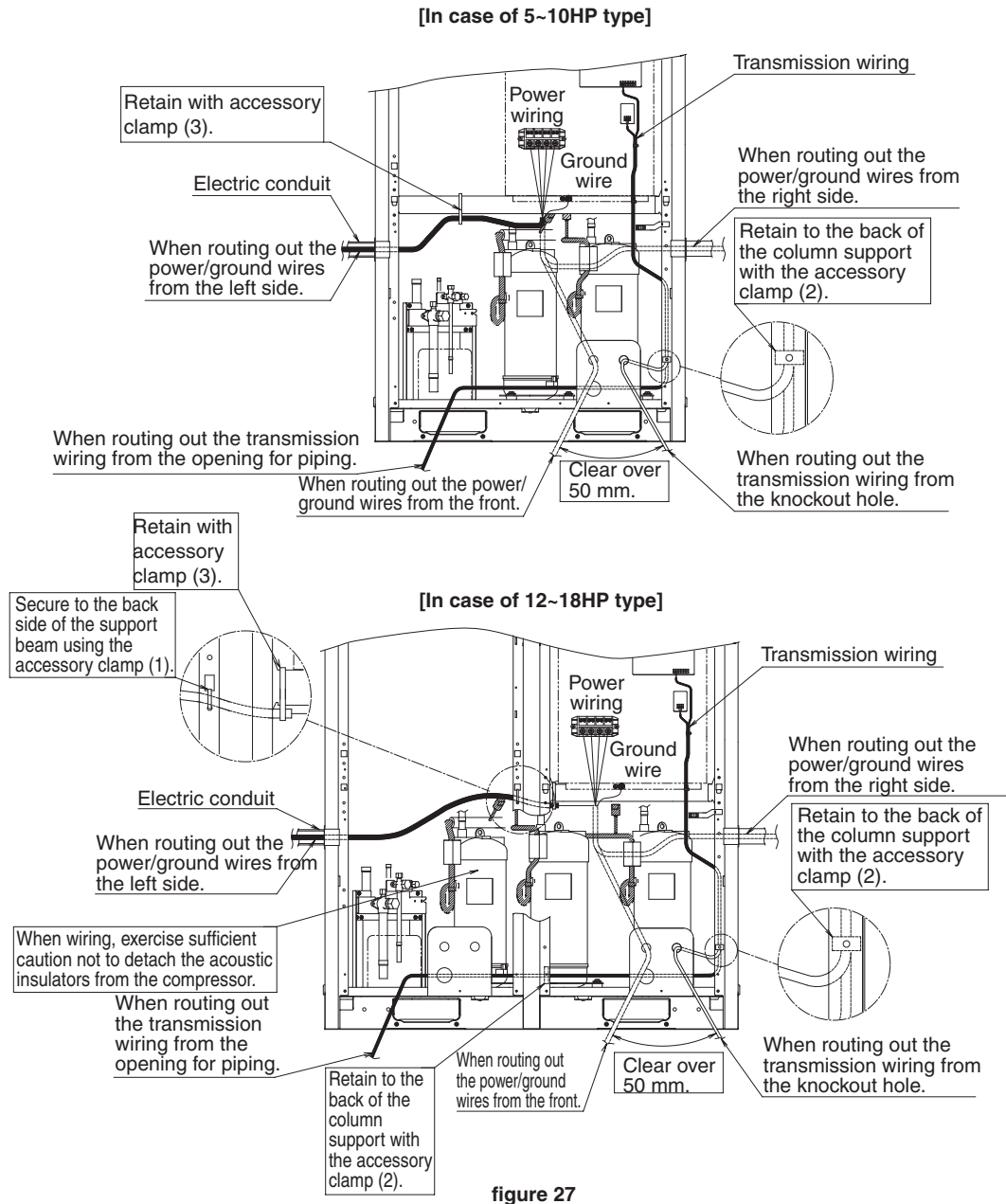

Caution:

- The transmission wiring must be at least 50 mm away from the power wiring.
- Make sure all wiring do not contact to the pipes (hatching parts in the figure 27).
- After wiring work is completed, check to make sure there are no loose connections among the electrical parts in the EL.COMPO.BOX.

1.8 Air Tight Test and Vacuum Drying

- Note:**
- Always use nitrogen gas for the airtightness test.
 - Absolutely do not open the shutoff valve until the main power circuit insulation measurement has been completed. (measuring after the shutoff valve is opened will cause the insulation value to drop.)

1.8.1 Preparations

<Needed tools>

Gauge manifold Charge hose valve	<ul style="list-style-type: none"> To prevent entry of any impurities and insure sufficient pressure resistance, always use the special tools dedicated for R-410A. Use charge hose that have pushing stick for connecting to service port of shutoff valves or refrigerant charge port.
Vacuum pump	<ul style="list-style-type: none"> The vacuum pump for vacuum drying should be able to lower the pressure to -100.7kPa (5 Torr -755mm Hg). Take care the pump oil never flow backward into the refrigerant pipe during the pump stops.

<The system for air tight test and vacuum drying>

- Referring to figure 28, connect an nitrogen tank, refrigerant tank, and a vacuum pump to the outdoor unit.
The refrigerant tank and the charge hose connection to refrigerant charge port or the valve A, C in figure 28 are needed in "1-11. Additional Refrigerant Charge and Check Operation".
- The shutoff valve and valve A~C in figure 28 should be open or closed as shown in the table below.

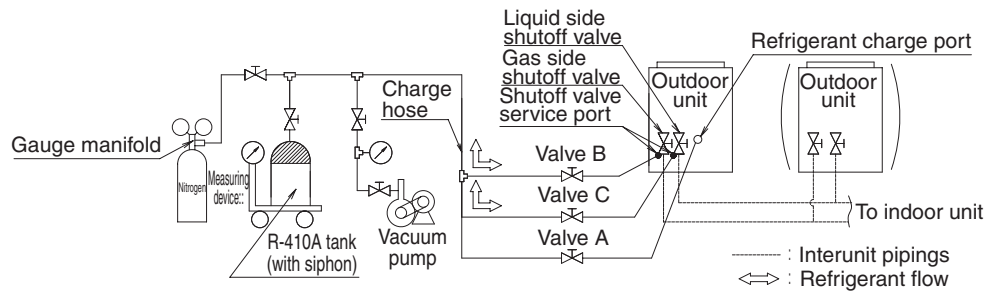
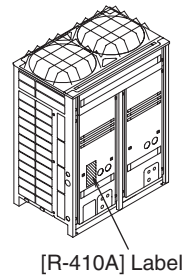

figure 28

State of valve A, B and C and shutoff valves	Valve			shutoff valve	
	A	B	C	Liquid side	Gas side
Air tight test, Vacuum drying (Close valve A and shutoff valves certainly. Otherwise the refrigerant in the unit are released.)	Close	Open	Open	Close	Close

- Note:**
- The airtightness test and vacuum drying should be done using the liquid side and gas side shutoff valve service ports.
See the [R-410A] Label attached to the front plate of the outdoor unit for details on the location of the service port (see figure at right).
 - See [Shutoff valve operation procedure] in "1-11-1 Before working" for details on handling the shutoff valve.
 - The refrigerant charge port is connected to unit pipe.
When shipped, the unit contains the refrigerant, so use caution when attaching the charge hose.



1.8.2 Air tight test and vacuum drying method

After finished piping work, carry out air tight test and vacuum drying.

<Air tight test>

Pressurize the liquid and gas pipes to 4.0MPa (40bar) (do not pressurize more than 4.0MPa (40bar)). If the pressure does not drop within 24 hours, the system passes the test.

If there is a pressure drop, check for leaks, make repairs and perform the airtight test again.

<Vacuum drying>

Evacuate the system from the liquid and gas pipes by using a vacuum pump for more than 2 hours and bring the system to -100.7kPa or less. After keeping the system under that condition for more than 1 hour, check if the vacuum gauge rises or not. If it rises, the system may either contain moisture inside or have leaks.



Note:

If moisture might enter the piping, follow below.

(I.e., if doing work during the rainy season, if the actual work takes long enough that condensation may form on the inside of the pipes, if rain might enter the pipes during work, etc.)

- (1) After performing the vacuum drying for two hours, pressurize to 0.05 MPa (i.e., vacuum breakdown) with nitrogen gas, then depressurize down to -100.7 kPa for an hour using the vacuum pump (vacuum drying).
- (2) If the pressure does not reach -100.7 kPa even after depressurizing for at least two hours, repeat the vacuum breakdown - vacuum drying process.

After vacuum drying, maintain the vacuum for an hour and make sure the pressure does not rise by monitoring with a vacuum gauge.

1.9 Pipe Insulation

- Insulation of pipes should be done after performing “**1-8 Air Tight Test and Vacuum Drying**”.
- Always insulate the liquid side piping and gas side piping in the interunit piping and refrigerant branching kit. Failing to insulate the pipes could cause leaking or burns. (The gas side piping can reach temperatures of 120°C. Be sure the insulation used can withstand such temperatures.)
- Reinforce the insulation on the refrigerant piping according to the installation environment. Condensation might form on the surface of the insulation.
 - ◆ Ambient temperature: 30°C, humidity: 75% to 80% RH: min. thickness: 15 mm.
 - ◆ If the ambient temperature exceeds 30°C and the humidity 80% RH, then the min. thickness is 20 mm.
- If there is a possibility that condensation on the shutoff valve might drip down into the indoor unit through gaps in the insulation and piping because the outdoor unit is located higher than the indoor unit, etc., this must be prevented by caulking the connections, etc. (**Refer to figure 29**)
- The piping lead-out hole lid should be attached after opening a knock hole. (**Refer to figure 30**)
- If small animals and the like might enter the unit through the piping lead-out hole, close the hole with blocking material (procured on site) after completion of “**1-11. Additional Refrigerant Charge and Check Operation**”. (**Refer to figure 30**)

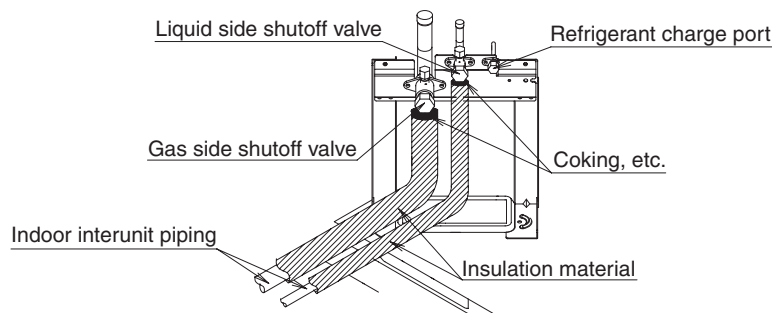

figure 29

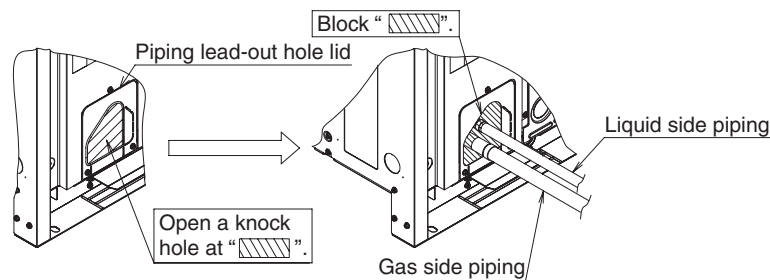

figure 30



- Note:**
- After knocking out the holes, we recommend you remove burrs in the knock holes (see figure 30) and paint the edges and areas around the edges using the repair paint.

1.10 Checking of Device and Installation Conditions

Be sure to check the followings.

For those doing electrical work

1. Make sure there is no faulty transmission wiring or loosen a nut.
See “**1-7-4 Transmission Wiring Connection Procedure**”.
2. Make sure there is no faulty power wiring or loosen a nut.
See “**1-7-5 Power Wiring Connection Procedure**”.
3. Has the insulation of the main power circuit deteriorated?
4. Measure the insulation and check the insulation is above regular value in accordance with relevant local and national regulations.

For those doing pipe work

1. Make sure piping size is correct.
See “**1-6-1 Selection of piping material and Refrigerant branching kit**”.
2. Make sure insulation work is done.
See “**1-9 Pipe Insulation**”.
3. Make sure there is no faulty refrigerant piping.
See “**1-6 Refrigerant Piping**”.



1.11 Additional Refrigerant Charge and Check Operation

The outdoor unit is charged with refrigerant when shipped from the factory, but depending on the size and length of the piping when installed, it may require additional charging. For charging the additional refrigerant, follow the procedure in this chapter. And then carry out the check operation.

1.11.1 Before working

[About the refrigerant tank]

Check whether the tank has a siphon pipe before charging and place the tank so that the refrigerant is charged in liquid form. (See the figure below.)

With siphon pipe
 <p>Stand the tank upright and charge. (The siphon pipe goes all the way inside, so the tank does not need be put upside-down charge in liquid form.)</p>
Other tanks
 <p>Stand the tank upside-down and charge.</p>



Caution:

- Always use the proper refrigerant (R-410A). If charged with the refrigerant containing an improper material, it may cause an explosion or accident.
- R-410A is a mixed refrigerant, so charging it as a gas will cause the refrigerant composition to change, which may prevent normal operation.

[Shutoff valve operation procedure]

When operating the shutoff valve, follow the procedure instructed below.



Note:

- Do not open the shutoff valve until “1-10 Checking of Device and Installation Conditions” are completed. If the shutoff valve is left open without turning on the power, it may cause refrigerant to buildup in the compressor, leading insulation degradation.
- Be sure to use the correct tools.
The shutoff valve is not a back-seat type. If forced it to open, it might break the valve body.
- When using a service port, use the charge hose.
- After tightening the cap, make sure no refrigerant gas is leaking.

[Tightening torque]

The sizes of the shutoff valves on each model and the tightening torque for each size are listed in the table below.

<Size of Shutoff Valve>

	5HP type	8HP type	10HP type	12HP type	14HP type	16HP type	18HP type
Liquid side shutoff valve	ϕ 9.5 The 12HP type corresponds to the 12.7-diameter onsite piping using the included piping.				ϕ 12.7 The 18HP type corresponds to the 15.9-diameter onsite piping using the accessory pipe.		
Gas side shutoff valve	ϕ 15.9	ϕ 19.1	ϕ 25.4 The 10HP type corresponds to the 22.2-diameter onsite piping using the accessory pipe. The 12 ~ 18HP type corresponds to the 28.6-diameter onsite piping using the accessory pipe.				

<Tightening torque>

Shutoff valve size	Tightening torque N·m (Turn clockwise to close)		
	Shaft (valve body)	Cap (valve lid)	Service port
φ 9.5	5.4 - 6.6	Hexagonal wrench 4 mm	13.5 - 16.5
φ 12.7	8.1 - 9.9		
φ 15.9	13.5 - 16.5	Hexagonal wrench 6 mm	22.5 - 27.5
φ 19.1	27.0 - 33.0		
φ 25.4		Hexagonal wrench 8 mm	11.5 - 13.9

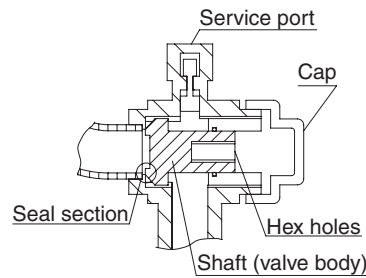

figure 34

[To open]

1. Remove the cap and turn the shaft counterclockwise with the hexagon wrench (JISB4648).
2. Turn it until the shaft stops.
3. Make sure to tighten the cap securely.
(For the tightening torque, refer to the item <Tightening Torque>.)

[To close]

1. Remove the cap and turn the shaft clockwise with the hexagon wrench (JISB4648).
2. Securely tighten the valve until the shaft contacts the main body seal.
3. Make sure to tighten the cap securely.
(For the tightening torque, refer to the item <Tightening Torque>.)

[How to Check How Many Units are Connected]

It is possible to find out how many indoor or outdoor unit in the system are turned on by operating the push button on the PC-board (A1P) of outdoor unit (In case of multi system master unit).

Follow the procedure below to check how many indoor or outdoor units are turned on.

(LED display: ● ...OFF ☼ ...ON ⚡ ...Blinking * ...Uncertain)		LED display						
		H1P	H2P	H3P	H4P	H5P	H6P	H7P
(1)	Press the MODE button (BS1) once, and set the MONITOR MODE (H1P: Blinking).	⚡	●	●	●	●	●	●
(2)	Press the SET button (BS2) the number of times until the LED display matches that at right. For checking the number of outdoor units: eight times For checking the number of indoor units: five times	⚡	●	●	☼	●	●	●
		⚡	●	●	●	☼	●	☼
(3)	Press the RETURN button (BS3) and read the number of units from the display of H2P through H7P. [Reading Method] The display of H2P through H7P should be read as a binary number, with ⚡ standing for "1" and ● standing for "0".	⚡	*	*	*	*	*	*
<p>Ex: For the LED display at right, this would be "010110", which would mean 22 units are connected.</p> <p>Note: "000000" indicates 64 units.</p>		⚡	●	⚡	●	⚡	⚡	●
(4)	Press the MODE button (BS1) once. This returns to Setting Mode 1 (default).	●	●	☼	●	●	●	●

Note: Press the "MODE button" (BS1) if you get confused while operating. This returns to **Setting Mode 1** (default).

1.11.2 Procedure of Adding Refrigerant charging and check operation



Warning



Electric Shock Warning:

- Make sure to close the EL. COMPO. BOX lid before turning on the power when performing the refrigerant charging operation.
- Perform the setting on the PC-board (A1P) of the outdoor unit and check the LED display after the power is on via the inspection door which is in the EL. COMPO. BOX lid.
- Use an insulated rod to operate the push buttons via the EL. COMPO. BOX's inspection door.

There is a risk of electric shock if you touch any live parts, since this operation must be performed with the power on.



Caution:

- Make sure to use the protect tool (protective groves and goggles) when charging the refrigerant.
- Due to a danger of liquid hammer, the refrigerant must not be charged over the allowable maximum amount when charging the refrigerant.
- Do not perform the refrigerant charging operation under working for the indoor unit.
- When opening the front panel, make sure to take caution to the fan rotation during the working.

After the outdoor unit stops operating, the fan may keep rotation for a while.



Note:

- If operation is performed within 12 minutes after the indoor and outdoor units are turned on, H2P will be lit on and the compressor will not operate.
- In order to ensure uniform refrigerant distribution, it may take up to around 10 minutes for the compressor to start up after the unit starting operating. This is not a malfunction.

<About refrigerant charging>

- The refrigerant charge port is connected to the piping inside the unit.
When the unit is shipped from the factory, the unit's internal piping is already charged with refrigerant, so be careful when connecting the charge hose.
- After adding the refrigerant, make sure to close the lid of the refrigerant charging port.
The tightening torque for the lid is 11.5 to 13.9 Nm.
- See [Shutoff valve operation procedure] in chapter 1-11-1 for details on how to handle shutoff valves.
- When done or when pausing the refrigerant charging operation, close the valve of the refrigerant tank immediately. If the tank is left with the valve open, the amount of refrigerant which is properly charged may be off the point. More refrigerant may be charged by any remaining pressure after the machine is stopped.

<About check operation>

- Make sure to perform the check operation after installation. Otherwise, the malfunction code "U3" will be displayed and normal operation cannot be performed.
And the failure of "Check of miswiring" may also cause abnormal operation. Performance may drop due to the failure of "Judgment of piping length".
- Check operation must be performed for each refrigerant piping system.
Checking is impossible if plural systems are being done at once.
- The individual problems of indoor units can not be checked.
About these problems check by test run after the check operation is completed. (See chapter 1-13)
- The check operation cannot be performed in recovery or other service modes.

1. Make sure the following works are complete in accordance with the installation manual.
 - Piping work
 - Wiring work
 - Air tight test
 - Vacuum drying
 - Installation work for indoor unit
2. Calculate the "additional charging amount" using "How to calculate the additional refrigerant to be charged" in "1-6-5 Example of connection".
3. Open the valve C (See the figure 31. The valve A, B and the liquid and gas side shutoff valve must be left closed), and charge the refrigerant of the "additional charging amount" from the liquid side shutoff valve service port.
If the "additional charging amount" was charged fully, close the valve C and go to step 5.
If the "additional charging amount" was not charged fully, go to step 4.

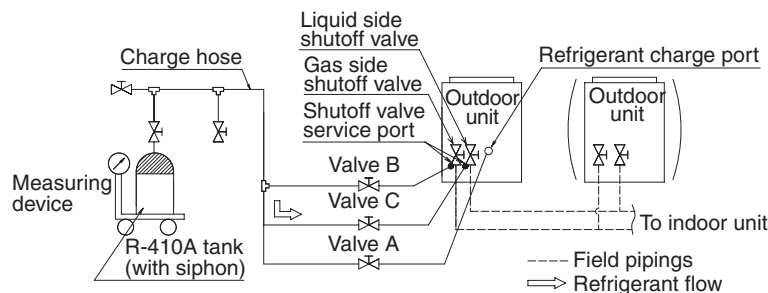

figure 31

- Perform the refrigerant charging operation following [Refrigerant charging operation procedure] as shown below, and charge the remaining refrigerant of the “additional charging amount”. For performing the refrigerant charging operation the push button on the PC-board (A1P) of outdoor unit (In case of multi system master unit) are use. (See the figure 32) In addition, the refrigerant are charged from the refrigerant charge port via the valve A. (See the figure 33)
For operating the push button and opening and closing the valve, follow the work procedure.



Note: The refrigerant will be charged about 22kg in one hour at outdoor temp. 30°C DB (6kg at 0°C DB).
If you need to speedup in case of multi system, connect the refrigerant tanks to each outdoor unit as shown in the figure 33.

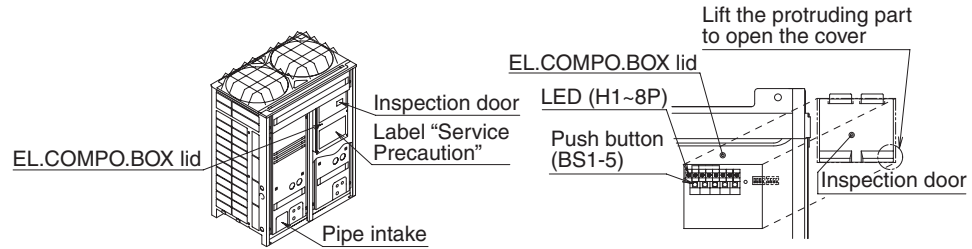

figure 32

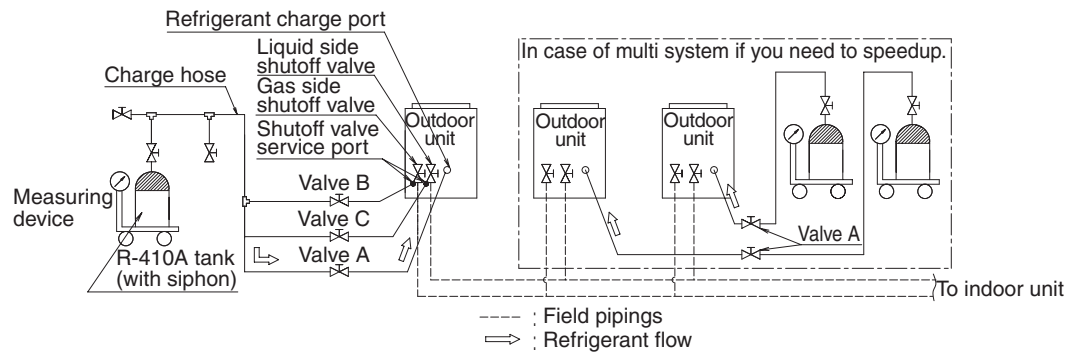

figure 33

[Refrigerant Charging Operation Procedure]

- Open the liquid and gas side shutoff valves (The valve A~C must be closed. The valve A~C means the valves in the figure 33.)

[Display of normal system]

LED display (Default status of shipped)	SERV. MONITOR	MODE	TEST/HWL	C/H SELECTOR			L.N.O.P	DEMA-ND	MULTI
				IND	MASTER	SLAVE			
				H3P	H4P	H5P			
Single system	●	●	●	☼	●	●	●	●	●
Multi system (*)	Master unit	●	●	●	☼	●	●	●	☼
	Sub unit 1	●	●	●	●	●	●	●	●
	Sub unit 2	●	●	●	●	●	●	●	●

LED display: ●...OFF, ☼...ON, ●...Blinking

(*)How to distinguish the master unit, sub unit 1, and sub unit 2 in the multi system.

Method 1: By the H8P (MULTI) LED display

☀ (ON): Master unit	⏻ (Blinking): Sub unit 1	● (OFF): Sub unit 2
---------------------	--------------------------	---------------------

Method 2: By the transmission wiring to indoor unit

Transmission wiring is connected: Master unit
Transmission wiring is not connected : Sub unit 1 or Sub unit 2

- (2) If necessary, set the field setting by using the dip switch on the outdoor unit PC-board (A1P).
(For how to set, see "1-12-1 Onsite Settings With the Power Off")
 - (3) • Close the EL. COMPO. BOX lid and all front panel except on the side of the EL. COMPO. BOX (*1) and turn the power to the outdoor unit and all connected indoor units. (*2)
 - After H2P stop blinking (about 12 minutes after turning on the power), check LED displays as shown in the table [Display of normal system] and the system is normal state.
If H2P is blinking, check the malfunction code in the remote control, and correct the malfunction in accordance with [remote control display malfunction code] in step 5.
 - (*1) Lead the refrigerant charge hose etc., from the pipe intake. All front panels must be closed at the procedure (9).
 - (*2) • If you perform the refrigerant charging operation within the refrigerant system that have the power off unit, the operation cannot finish properly.
For confirming the number of the outdoor and indoor units with the power on, see [How to check how many units are connected] in chapter 1-11-1. In case of a multi system, turn on the power to all outdoor units in the refrigerant system.
 - To energize the crankcase heater, make sure to turn on for 6 hours before starting operation.
 - (4) Start the additional refrigerant charge operation.
(About the system settings for additional refrigerant charge operation, refer to the [Service Precaution] label attached on the EL. COMPO. BOX lid in the outdoor unit.)
Open valve A immediately after starting the compressor.
 - (5) Close the valve A if the "additional charging amount" of refrigerant was charged, and push the RETURN button (BS3) once.
 - (6) Record the charging amount on the accessory "REQUEST FOR THE INDICATION" label and attach it to the back side of the front panel.
5. After completing the additional refrigerant charging perform the check operation following below.

**Note:**

- For check operation, the following work will be performed.
 - ◆ Check of shutoff valve opening
 - ◆ Check of miswiring
 - ◆ Judgment of piping length
 - ◆ Check of refrigerant overcharge
- It takes about 40 minutes to complete the check operation.

[Check Operation Procedure]

- (1) Make the onsite setting as needed using the dip switches on the outdoor unit PC-board (A1P) with the power off (See "1-12-1 Onsite Settings With the Power Off")
- (2) Close the EL. COMPO. BOX lid and all front panels except as the side of the EL. COMPO. BOX and turn on the power to the outdoor unit and all connected indoor units. (Be sure to turn the power on at least 6 hours before operation in order to have power running to the crank case heater.)

- (3) Check the LED display on the outdoor unit PC-board (A1P) is as shown in the table below and transmission is normal.

LED display (Default status of shipped)	SERV. MONITOR	MODE	TEST/HWL	C/H SELECTOR			L.N.O.P	DEMA-ND	MULTI
				IND	MASTER	SLAVE			
	HAP	H1P	H2P	H3P	H4P	H5P	H6P	H7P	H8P
Single system	●	●	●	☀	●	●	●	●	●
Multi system (*)	Master unit	●	●	☀	●	●	●	●	☀
	Sub unit 1	●	●	●	●	●	●	●	●
	Sub unit 2	●	●	●	●	●	●	●	●

LED display: ●...OFF, ☀...ON, ●...Blinking

(*)How to distinguish the master unit, sub unit 1, and sub unit 2 in the multi system.

Method 1: By the H8P (MULTI) LED display

☀ (ON): Master unit	● (Blinking): Sub unit 1	● (OFF): Sub unit 2
---------------------	--------------------------	---------------------

Method 2: By the transmission wiring to indoor unit

Transmission wiring is connected: Master unit
Transmission wiring is not connected : Sub unit 1 or Sub unit 2

- (4) Make the onsite settings as needed using the push button (BS1-BS5) on the outdoor unit PC-board (A1P) with the power on. (See “1-12-2 Onsite Settings With the Power On”)
- (5) Perform the check operation following the Check Operation Method of the [Service Precautions] label on the EL. COMPO. BOX lid. The system operation for about 40 minutes and automatically stops the check operation.

If the malfunction code is not displayed in the remote control after the system stop, check operation is completed. Normal operation will be possible after 5 minutes. If the malfunction code is displayed in the remote control, correct the malfunction following [remote control displays malfunction code] and perform the check operation again.

[remote control displays malfunction code]

Malfunction code	Installation error	Remedial action
E3, E4 F3, F6 UF	The shutoff valve of the outdoor unit is left closed.	Open the shutoff valve.
U1	The phases of the power to the outdoor unit is reversed.	Exchange two of the three phases (L1, L2, L3) to make a proper connection.
U1 U4 LC	No power is supplied to an outdoor or indoor unit (including phase interruption).	Make sure the power source wire is properly connected to the outdoor unit and revise if necessary.
UF	There is conflict on the connection of transmission wiring in the system.	Check if the refrigerant piping line and the transmission wiring are consistent with each other.
E3 F6 UF	Refrigerant overcharge.	Recalculate the additional amount refrigerant from the piping length and correct the refrigerant charge level by recovering any excessive refrigerant with a refrigerant recovery machine.
E4 F3	Insufficient refrigerant.	<ul style="list-style-type: none"> ■ Check if the additional refrigerant charge has been finished correctly. ■ Recalculate the additional amount refrigerant from the piping length and add the adequate amount.
U7, U4 UF, UH	If the outdoor unit terminal is connected when there is one outdoor unit installed.	Remove the line from the outdoor multi terminals (Q1 and Q2).

If any malfunction codes other than the above are displayed, check the service manual for how to respond.

1.12 Onsite Settings



Note: In the case of a multi system, all onsite settings should be made on the master unit. Settings made on sub units are invalid.
The outdoor unit to which the indoor unit transmission wire are connected is the master unit, and all other units are sub units.

1.12.1 Onsite Settings With the Power Off

If the COOL/HEAT selector was connected to the outdoor unit in “1-7 Field Wiring”, set the dip switch (DS1) on the outdoor unit PC-board (A1P) to “ON” (it is set to “OFF” when shipped from the factory).

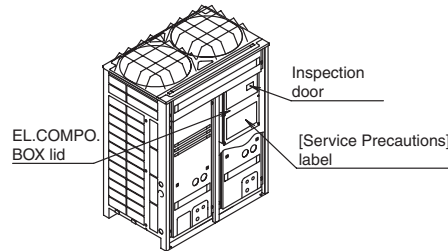

For the position of the dip switch (DS1), see the “Service Precautions” label (see at right) which is attached to the EL. COMPO. BOX lid.



Warning



Electric Shock Warning:

Never perform with the power on.

There is a serious risk of electric shock if any live part is touched.

1.12.2 Onsite Settings with the Power On

Use the push button switches (BS1 through BS5) on the outdoor unit PC-board (A1P) to make the necessary onsite settings.

See the “Service Precautions” label on the EL. CONPO. BOX lid for details on the positions and operating method of the push button switches and on the onsite setting.

Make sure to record the setting on the accessory “REQUEST FOR THE INDICATION” label.



Warning



Electric Shock Warning:

Use an insulated rod to operate the push buttons via the inspection door of EL. COMPO. BOX lid.

There is a risk of electric shock if you touch any live parts, since this operation must be performed with the power on.

1.13 Test Run

1.13.1 Before Test Run

- Make sure the following works are completed in accordance with the installation manual.
 - ◆ Piping work
 - ◆ Wiring work
 - ◆ Air tight test
 - ◆ Vacuum drying
 - ◆ Additional refrigerant charge
- Check that all work for the indoor unit are finished and there are no danger to operate.

1.13.2 Test Run

After check operation is completed, operate the unit normally and check the following.

1. Make sure the indoor and outdoor units are operating normally.
2. Operate each indoor unit one by one and make sure the corresponding outdoor unit is also operating.
3. Check to see if cold (or hot, except RXQ-P) air is coming out from the indoor unit.
4. Push the fan direction and strength buttons on the remote control to see if they operate properly.



Note:

- Heating is not possible if the outdoor temperature is 24°C or higher. Refer to the Operation manual.
- If a knocking sound can be heard in the liquid compression of the compressor, stop the unit immediately and then energize the crank case heater for a sufficient length of time before restarting the operation.
- Once stopping, the compressor will not restart in about 5 minutes even if the On/Off button of the remote control is pushed.
- When the system operation is stopped by the remote control, the outdoor units may continue operating for further 5 minutes at maximum.
- The outdoor unit fan may rotate at low speeds if the Night-time low noise setting or the External low noise level setting is made, but this is not a malfunction.

1.13.3 Checks after Test Run

Perform the following checks after the test run is complete.

- Record the contents of field setting.
 - Record them on the accessory “REQUEST FOR THE INDICATION” label.
And attach the label on the back side of the front panel.
- Record the installation date.
 - Record the installation date on the accessory “REQUEST FOR THE INDICATION” label in accordance with the IEC60335-2-40.
And attach the label on the back side of the front panel.



Note:

After the test run, when handing the unit over to the customer, make sure the EL.COMPO.BOX lid, the inspection door, and the unit casing are all attached.

1.14 Caution for Refrigerant Leaks

(Points to note in connection with refrigerant leaks)

Introduction

The installer and system specialist shall secure safety against leakage according to local regulations or standards. The following standards may be applicable if local regulations are not available.

The VRV System, like other air conditioning systems, uses R-410A as refrigerant. R-410A itself is an entirely safe non-toxic, non-combustible refrigerant. Nevertheless care must be taken to ensure that air conditioning facilities are installed in a room which is sufficiently large. This assures that the maximum concentration level of refrigerant gas is not exceeded, in the unlikely event of major leak in the system and this in accordance to the local applicable regulations and standards.

Maximum concentration level

The maximum charge of refrigerant and the calculation of the maximum concentration of refrigerant is directly related to the humanly occupied space in to which it could leak.

The unit of measurement of the concentration is kg/m^3 (the weight in kg of the refrigerant gas in 1m^3 volume of the occupied space).

Compliance to the local applicable regulations and standards for the maximum allowable concentration level is required.

In Australia the maximum allowed concentration level of refrigerant to a humanly space is limited to $0.35\text{kg}/\text{m}^3$ for R-407C and $0.44\text{kg}/\text{m}^3$ for R-410A.

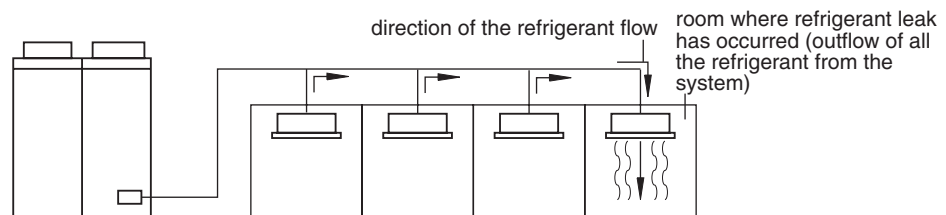

Pay a special attention to the place, such as a basement, etc. where refrigerant can stay, since refrigerant is heavier than air.

Procedure for checking maximum concentration

Check the maximum concentration level in accordance with steps 1 to 4 below and take whatever action is necessary to comply.

1. Calculate the amount of refrigerant (kg) charged to each system separately.

amount of refrigerant in a single unit system (amount of refrigerant with which the system is charged before leaving the factory)	+	additional charging amount (amount of refrigerant added locally in accordance with the length or diameter of the refrigerant piping)	=	total amount of refrigerant (kg) in the system
---	---	--	---	--



Note:

- Where a single refrigerant facility is divided into 2 entirely independent refrigerant systems then use the amount of refrigerant with which each separate system is charged.

2. Calculate the smallest room volume (m^3)
In case like the following, calculate the volume of (A), (B) as a single room or as the smallest room.

A. Where there are no smaller room divisions

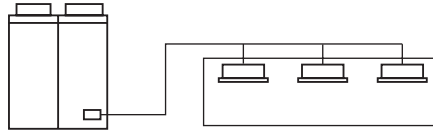

B. Where there is a room division but there is an opening between the rooms sufficiently large to permit a free flow of air back and forth.

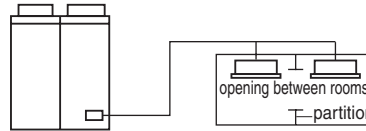

(Where there is an opening without a door or where there are openings above and below the door which are each equivalent in size to 0.15% or more of the floor area.)

3. Calculating the refrigerant density using the results of the calculations in steps 1 and 2 above.

$$\frac{\text{total volume of refrigerant in the refrigerant system}}{\text{size (m}^3\text{) of smallest room in which there is an indoor unit installed}} \leq \text{maximum concentration level (kg/m}^3\text{)}$$

If the result of the above calculation exceeds the maximum concentration level then make similar calculations for the second then third smallest room and so until the result falls short of the maximum concentration.

4. Dealing with the situations where the result exceeds the maximum concentration level.
Where the installation of a facility results in a concentration in excess of the maximum concentration level then it will be necessary to revise the system. Please consult your Daikin supplier.

2. Heat Pump 60Hz (RXYQ5~54P)



INSTALLATION MANUAL

VRV III System air conditioner

RXYQ5PYL(E)
RXYQ8PYL(E)
RXYQ10PYL(E)
RXYQ12PYL(E)
RXYQ14PYL(E)
RXYQ16PYL(E)
RXYQ18PYL(E)
RXYQ20PYL(E)
RXYQ22PYL(E)
RXYQ24PYL(E)
RXYQ26PYL(E)
RXYQ28PYL(E)
RXYQ30PYL(E)
RXYQ32PYL(E)
RXYQ34PYL(E)
RXYQ36PYL(E)
RXYQ38PYL(E)
RXYQ40PYL(E)
RXYQ42PYL(E)
RXYQ44PYL(E)
RXYQ46PYL(E)
RXYQ48PYL(E)
RXYQ50PYL(E)
RXYQ52PYL(E)
RXYQ54PYL(E)

2.1 First of All

- This document is an installation manual for the Daikin RXYQ-P Series VRV Inverter. Before installing the unit, read this manual thoroughly, and following the instructions contained in it. After installation, do a test run to make sure the unit runs properly, and then explain how to operate and take care of the unit to the customer, using the operation manual.
- Lastly, make sure the customer keeps this manual, along with the operation manual, in a safe place.
- This manual does not describe how to install the indoor unit.
Refer to the installation manual included with the indoor unit for that.

2.1.1 Safety considerations

Please read these “Safety considerations” carefully before installing air conditioning unit and be sure to install it correctly. The safety precautions listed here are divided into two categories. In either case, important safety information is listed which must be read carefully.



Warning: Failure to observe a warning may result in death or serious injury.



Caution: Failure to observe a caution may result in injury or damage to the unit. These too might lead to serious injury depending on the circumstances.



- Warning:**
- Ask your dealer or qualified personnel to carry out installation work. Do not try to install the machine yourself.
Improper installation may result in water leakage, electric shocks or fire.
 - Perform installation work in accordance with this installation manual.
Improper installation may result in water leakage, electric shocks or fire.
 - When installing the unit in a small room, take measures against to keep refrigerant concentration from exceeding allowable safety limits in the event of refrigerant leakage.
Contact your dealer for more information. Excessive refrigerant in a closed ambient can lead to oxygen deficiency.
 - Be sure to use only the specified accessories and parts for installation work.
Failure to use the specified parts may result in water leakage, electric shocks, fire or the unit falling.
 - Install the air conditioner on a foundation strong enough to withstand the weight of the unit.
A foundation of insufficient strength may result in the unit falling and causing injuries.
 - Carry out the specified installation work after taking into account strong winds, typhoons or earthquakes.
Improper installation work may result in the unit falling and causing accidents.
 - Make sure that a separate power supply circuit is provided for this unit and that all electrical work is carried out by qualified personnel according to local and national regulations and this installation manual.
An insufficient power supply capacity or improper electrical construction may lead to electric shocks or fire.
 - Make sure that all wiring is secured, the specified wires are used, and no external forces act on the terminal connections or wires.
Improper connections or installation may result in the terminals overheating or fire.
 - When wiring the power supply and connecting the remote control wiring and transmission wiring, position the wires so that the EL.COMPO.BOX lid can be securely fastened.
Improper positioning of the EL.COMPO.BOX lid may result in electric shocks or fire.
 - If the refrigerant gas leaks during installation, ventilate the area immediately.
Toxic gas may be produced if the refrigerant gas comes into contact with fire.
 - After completing the installation work, check that the refrigerant gas does not leak.
Toxic gas may be produced if the refrigerant gas leaks into the room and comes into contact with a source of fire, such as a fan heater, stove or cooker.
 - Do not directly touch the refrigerant leaked from refrigerant piping connections.
Frostbite may be caused.
 - Before touching electrical parts, turn off the power.
 - Do not allow children to mount on the outdoor unit, or avoid placing any object on it. Falling or tumble may result in injury.

- Be sure to establish an earth.
Do not earth the unit to a utility pipe, arrester or telephone earth.
Incomplete earth may cause electrical shock or fire.
A high surge current from lightning or other sources may cause damage to the air conditioner.
- Be sure to install an earth leakage breaker.
Failure to install an earth leakage breaker may result in electric shocks or fire.

**Caution:**

- While following the instructions in this installation manual, install drain piping in order to ensure proper drainage and insulate piping in order to prevent condensation. Improper drain piping may result in water leakage and property damage.
- Install the indoor and outdoor units, power supply wiring and connecting wiring at least 1 meter away from televisions or radios in order to prevent image interference or noise. (Depending on the radio waves, a distance of 1 meter may not be sufficient enough to eliminate the noise.)
- The indoor unit should be installed as far away from fluorescent lighting as possible. remote control (wireless kit) transmitting distance can result shorter than expected in rooms with electronic fluorescent lamps (inverter or rapid start types).
- Do not install the air conditioner in the following locations:
 - (a) where a mineral oil mist or an oil spray or vapor is produced, for example in a kitchen. Plastic parts may deteriorate and fall off or result in water leakage.
 - (b) where corrosive gas, such as sulfurous acid gas, is produced. Corroding copper pipes or soldered parts may result in refrigerant leakage.
 - (c) near machinery emitting electromagnetic waves. Electromagnetic waves may disturb the operation of the control system and result in a malfunction of the unit.
 - (d) where flammable gas may leak, where there are carbon fiber or ignitable dust suspensions in the air, or where volatile flammables such as thinner or gasoline are handled. Operating the unit in such conditions may result in fire.
 - (e) Locations where small animals might build nests inside the unit. If small animals enter and come in contact with electrical parts, this can cause malfunctions, smoke, and fire.

2.1.2 Special Notice of Product

[CLASSIFICATION]

This air conditioner comes under the term “appliances not accessible to the general public”.

[EMC CHARACTERISTICS]

VRVIII System is a class A product. In a domestic environment this product may cause radio interference in which case the user may be required to take adequate measures.

[REFRIGERANT]

VRVIII System use R-410A refrigerant.

- The refrigerant R-410A requires strict cautions for keeping the system clean, dry and tight. Read the chapter “Refrigerant Piping” carefully and follow these procedures correctly.
 - A. Clean and dry
Foreign materials (including mineral oils such as SUNISO oil or moisture) should be prevented from getting mixed into the system.
 - B. Tight
Take care to keep the system tight when installing.
R-410A does not contain any chlorine, does not destroy the ozone layer, and does not reduce the earth’s protection against harmful ultraviolet radiation.
R-410A can contribute slightly to the greenhouse effect if it is released.
- Since R-410A is a mixed refrigerant, the required additional refrigerant must be charged in its liquid state. If the refrigerant is charged in a state of gas, its composition changes and the system will not work properly.

Limit by the total maximum refrigerant charge

The total maximum refrigerant charge of a VRVIII system must be below 100kg, this to be in accordance with CE requirement (EN60335-2-40 standard).

This means that in case the total maximum refrigerant charge of the system (factory and additional charge) is equal to or more than 100kg you must divide your multiple outdoor system into smaller independent systems, each containing less than 100kg refrigerant charge.

For factory charge, refer to the unit name plate.

[DESIGN PRESSURE]

Since design pressure is 4.0MPa or 40bar, the wall thickness of pipes should be more carefully selected in accordance with the relevant local and national regulations.

2.1.3 Disposal Requirements

Dismantling of the unit, treatment of the refrigerant, oil and eventual other parts, should be done in accordance with the relevant local and national regulations.

2.2 Introduction

- RXYQ-P series are designed for outdoor installation and used for cooling and heatpump applications. Outdoor units come in three standard sizes, and with a single system through a multi system combining up to three outdoor units, rated cooling capacity from 14.0 kW to 147 kW and rated heating capacity from 16.0 kW to 170 kW can be achieved.
- The RXYQ-P units can be combined with Daikin VRV series indoor units for air conditioning purposes. Always use appropriate indoor units compatible with R-410A. To lean which models of indoor units are compatible with R-410A, refer to the product catalogs.
To combine with other refrigerant indoor unit will cause malfunction.

2.2.1 Combination

The indoor units can be installed in the following range.

<Outdoor unit>	<Total capacity of indoor units>	<Total quantity of indoor units>
RXYQ5PYL(E)	62.5 ~ 250	12 units
RXYQ8PYL(E)	100 ~ 400	20 units
RXYQ10PYL(E)	125 ~ 500	25 units
RXYQ12PYL(E)	150 ~ 600	30 units
RXYQ14PYL(E)	175 ~ 700	35 units
RXYQ16PYL(E)	200 ~ 800	40 units
RXYQ18PYL(E)	225 ~ 900	45 units
RXYQ20PYL(E)	250 ~ 800	40 units
RXYQ22PYL(E)	275 ~ 880	44 units
RXYQ24PYL(E)	300 ~ 960	48 units
RXYQ26PYL(E)	325 ~ 1040	52 units
RXYQ28PYL(E)	350 ~ 1120	56 units
RXYQ30PYL(E)	375 ~ 1200	60 units
RXYQ32PYL(E)	400 ~ 1280	64 units
RXYQ34PYL(E)	425 ~ 1360	64 units
RXYQ36PYL(E)	450 ~ 1440	64 units
RXYQ38PYL(E)	475 ~ 1235	61 units
RXYQ40PYL(E)	500 ~ 1300	64 units
RXYQ42PYL(E)	525 ~ 1365	64 units
RXYQ44PYL(E)	550 ~ 1430	64 units
RXYQ46PYL(E)	575 ~ 1495	64 units
RXYQ48PYL(E)	600 ~ 1560	64 units
RXYQ50PYL(E)	625 ~ 1625	64 units
RXYQ52PYL(E)	650 ~ 1690	64 units
RXYQ54PYL(E)	675 ~ 1755	64 units



Note:

- Be sure to connect an R-410A indoor unit.
See the catalog for indoor unit models which can be connected.
- At above is the total capacity and total number of units of the indoor units when configured in a standard combination. See the technical reference for details on total capacity and total number of indoor units when using a configuration other than the standard combination. The standard combination are as follows.

<Combination unit>

RXYQ5PYL(E)
 RXYQ8PYL(E)
 RXYQ10PYL(E)
 RXYQ12PYL(E)
 RXYQ14PYL(E)
 RXYQ16PYL(E)
 RXYQ18PYL(E)
 RXYQ20PYL(E)
 RXYQ22PYL(E)
 RXYQ24PYL(E)
 RXYQ26PYL(E)
 RXYQ28PYL(E)
 RXYQ30PYL(E)
 RXYQ32PYL(E)
 RXYQ34PYL(E)
 RXYQ36PYL(E)
 RXYQ38PYL(E)
 RXYQ40PYL(E)
 RXYQ42PYL(E)
 RXYQ44PYL(E)
 RXYQ46PYL(E)
 RXYQ48PYL(E)
 RXYQ50PYL(E)
 RXYQ52PYL(E)
 RXYQ54PYL(E)

<Independent unit>

RXYQ5PYL(E)
 RXYQ8PYL(E)
 RXYQ10PYL(E)
 RXYQ12PYL(E)
 RXYQ14PYL(E)
 RXYQ16PYL(E)
 RXYQ18PYL(E)
 RXYQ8PYL(E)+ RXYQ12PYL(E)
 RXYQ10PYL(E)+ RXYQ12PYL(E)
 RXYQ8PYL(E)+ RXYQ16PYL(E)
 RXYQ8PYL(E)+ RXYQ18PYL(E)
 RXYQ10PYL(E)+ RXYQ18PYL(E)
 RXYQ12PYL(E)+ RXYQ18PYL(E)
 RXYQ16PYL(E)+ RXYQ16PYL(E)
 RXYQ16PYL(E)+ RXYQ18PYL(E)
 RXYQ18PYL(E)+ RXYQ18PYL(E)
 RXYQ8PYL(E)+ RXYQ12PYL(E) + RXYQ18PYL(E)
 RXYQ8PYL(E)+ RXYQ16PYL(E) + RXYQ16PYL(E)
 RXYQ8PYL(E)+ RXYQ16PYL(E) + RXYQ18PYL(E)
 RXYQ8PYL(E)+ RXYQ18PYL(E) + RXYQ18PYL(E)
 RXYQ10PYL(E)+ RXYQ18PYL(E) + RXYQ18PYL(E)
 RXYQ12PYL(E)+ RXYQ18PYL(E) + RXYQ18PYL(E)
 RXYQ14PYL(E)+ RXYQ18PYL(E) + RXYQ18PYL(E)
 RXYQ16PYL(E)+ RXYQ18PYL(E) + RXYQ18PYL(E)
 RXYQ18PYL(E)+ RXYQ18PYL(E) + RXYQ18PYL(E)

- If the total capacity of the connected indoor units exceeds the capacity of the outdoor unit, cooling and heating performance may drop when running the indoor units. See the capacity table in the Engineering Data Book for details.
- There are restrictions on the refrigerant pipe connecting order between outdoor unit in the case of the multi system.

Install so that the following restrictions are satisfied.

<Restrictions>



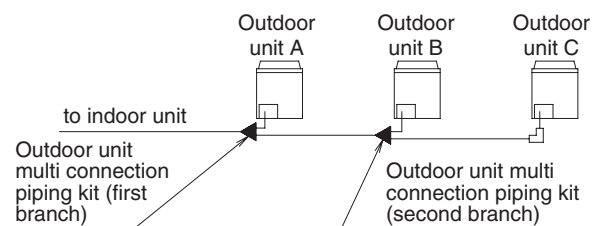

The capacities of outdoor units A, B and C must fulfill the following conditions.





$$A \geq B \geq C$$



2.2.2 Standard Supplied Accessories

The following accessories are included. The storage location of the accessories is shown in figure 1.

Q5~Q18 type				
Name	Clamp (1)	Clamp (2)	Clamp (3)	Gas side accessory pipe (1)
Quantity	9 pcs.	2 pcs.	1 pc.	1 pc.
Shape	 Small		 Large	

Q5~Q18 type				
Name	Gas side accessory pipe (2)	Liquid side accessory pipe (1)	Liquid side accessory pipe (2)	Others
Quantity	1 pc.	1 pc.	1 pc.	<ul style="list-style-type: none"> ■ Operation manual ■ Installation manual ■ "REQUEST FOR THE INDICATION" label (Installation records)
Shape	 5-10 HP type  12-18 HP type		 5-10, 14, 16 HP type  12, 18 HP type	

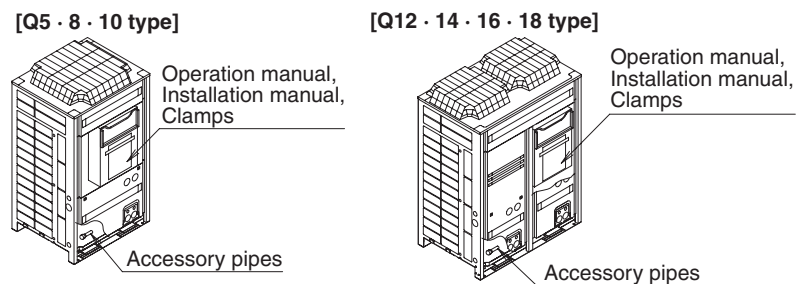

figure 1

i Note: Do not throw away any of the accessories until installation is complete.

2.2.3 Option Accessory

To install the outdoor units, the following optional parts are also required. To select an optimum kit, refer to "2-6 Refrigerant Piping".

■ Refrigerant branching kit

REFNET header	KHRP26M22H	KHRP26M33H	KHRP26M72H	KHRP26M73H
REFNET joint	KHRP26A22T	KHRP26A33T	KHRP26A72T	KHRP26A73T

■ Outdoor unit multi connection piping kit

Number of outdoor units connected	2 units	3 units
Kit name	BHFP22P100	BHFP22P151

■ Pipe size reducer

Kit name	KHRP26M73TP	KHRP26M73HP
----------	-------------	-------------

i Note: Make sure that any separately purchased accessories are designed for use with R-410A.

2.2.4 Technical and Electrical Specifications

Refer to the Engineering Data Book for the complete list of specifications.

2.2.5 Main Components

For main components and function of the main components, refer to the Engineering Data Book.

2.2.6 Installation Process

Figure 2 shows the installation process. Install in the order of the steps shown.

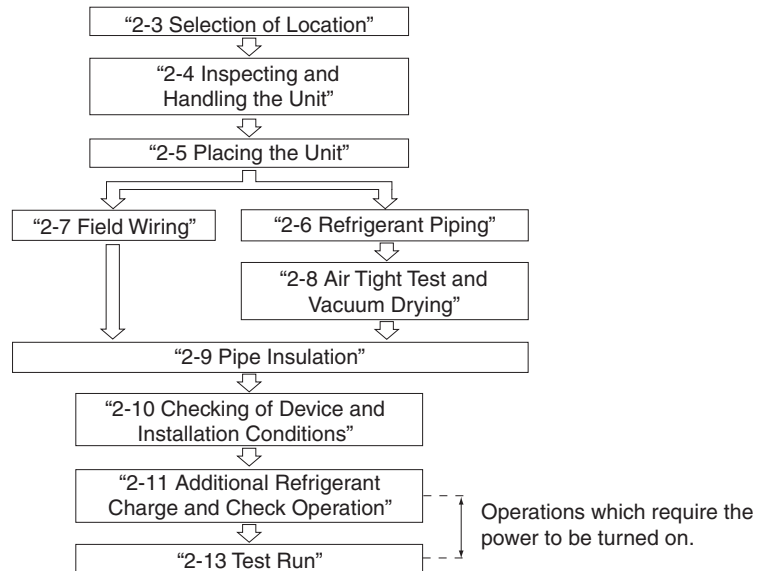

figure 2

2.3 Selection of Location

Select a location for installation that meets the following conditions. Get the customer's permission.

1. There is no danger of fire due to leakage of inflammable gas.
2. Select the location of the unit in such a way that neither the discharged air nor the sound generated by the unit disturb anyone.
3. The foundation is strong enough to support the weight of the unit and the floor is flat to prevent vibration and noise generation.
4. The piping length between the outdoor unit and the indoor unit may not exceed the allowable piping length. (Refer to "2-6. Refrigerant Piping")
5. Locations where the unit's suction vent and outlet vent do not generally face the wind. Wind blowing directly into the suction or outlet vents will interfere with the unit's operation. If necessary, install some kind of obstruction to block the wind.
6. The space around the unit is adequate for servicing and the minimum space for air inlet and air outlet is available. (See the "Installation Space Examples" for the minimum space requirements.)

Installation Space Examples

- The installation space requirement shown in figure 3 is a reference for cooling operation when the outdoor temperature is 35°C.
If the design outdoor temperature exceeds 35°C or the heat load exceeds maximum capacity in all the outdoor unit, take an even large space on the intake shown in figure 3.
- During installation, install the units using the most appropriate of the patterns shown in figure 3 for the location in question, taking into consideration human traffic and wind.
- If the number of units installed is more than that shown in the pattern in figure 3, install the units so there are no short circuits.
- As regards space in front of the unit, consider the space needed for the local refrigerant piping when installing the units.
- If the work conditions in figure 3 do not apply, contact your dealer or Daikin directly.

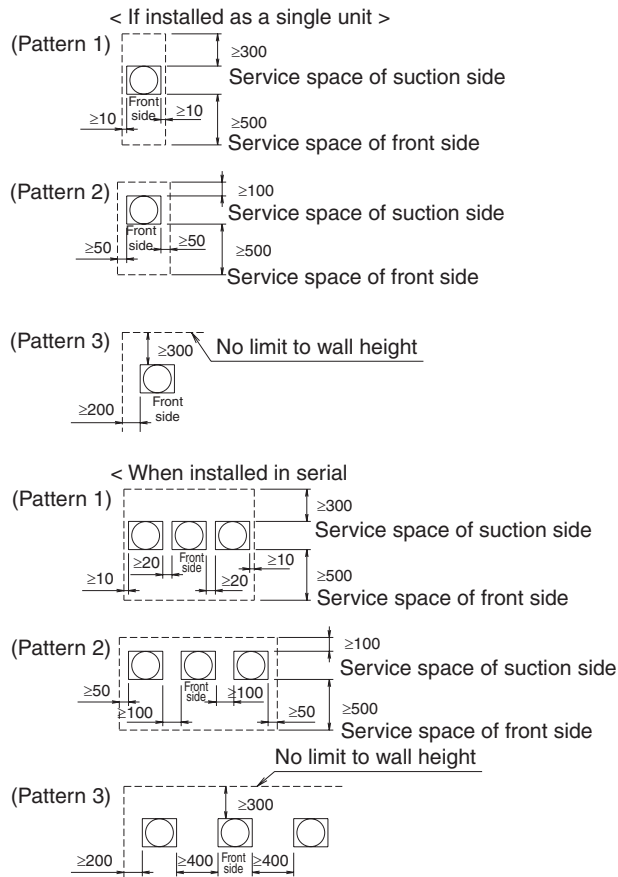
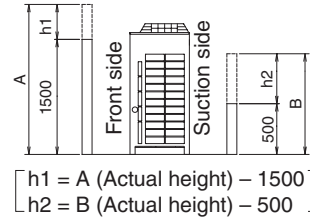

figure 3

For Patterns 1 and 2 in figure 3:

- Wall height for front side no higher than 1500 mm.
- Wall height on the suction side no higher than 500 mm.
- Wall height for sides – no limit.
- If the height is exceeded the above, calculate h1 and h2 shown in the figure below, and add h1/2 to the service space of front side and h2/2 to the service space of suction side.



Note:

1. An inverter air conditioner may cause electronic noise generated from AM broadcasting. Examine where to install the main air conditioner and electric wires, keeping proper distances away from stereo equipment, personal computers, etc. Particularly for locations with weak reception, ensure there is a distance of at least 3 meters for indoor remote controls, place power wiring and transmission wiring in conduits, and ground the conduits.

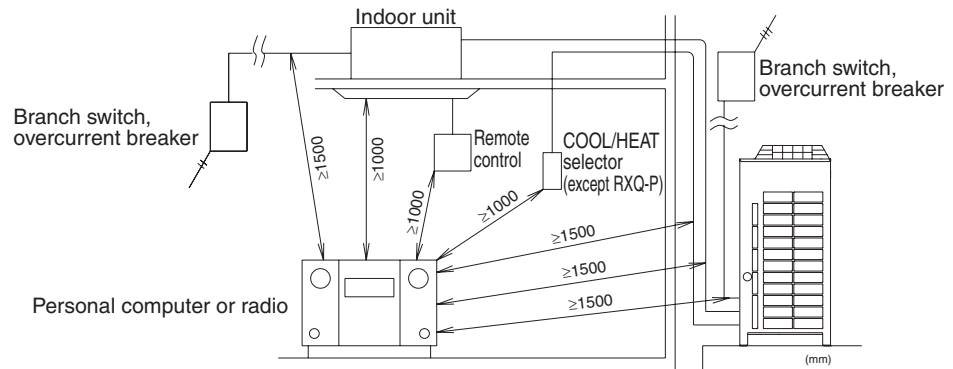



figure 4

2. When installing in a locations where there is heavy snowfall, implement the following snow measures.
 - Ensure the base is high enough that intakes are not clogged by snow.
 - Remove the rear intake grille to prevent snow from accumulating on the fins.
3. If condensate may drip on downstairs (or walkway) depending on the floor condition, take a measure such as the installation of central drain pan kit (sold separately).
4. The refrigerant R-410A itself is nontoxic, nonflammable and is safe. If the refrigerant should leak however, its concentration may exceed the allowable limit depending on room size. Due to this it could be necessary to take measures against leakage. See “2-14 Caution for Refrigerant Leaks” for details.

2.4 Inspecting and Handling the Unit

- At delivery, the package should be checked and any damage should be reported immediately to the carrier claims agent.
- When handling the unit, take into account the following:
 1.  Fragile, handle the unit with care.
 2.  Keep the unit upright in order to avoid compressor damage.
 2. Decide on the transportation route.
 3. If a forklift is to be used, pass the forklift arms through the large openings on the bottom of the unit. **(Refer to figure 5)**
 4. If hanging the unit, use a cloth sling to prevent damaging the unit. Keeping the following points in mind, hang the unit following the procedure shown in figure 6.
 - Use a sling sufficiently strong to hold the mass of the unit.
 - Use 2 belts of at least 8m long.
 - Place extra cloth or boards in the locations where the casing comes in contact with the sling to prevent damage.
 - Hoist the unit making sure it is being lifted at its center of gravity.
 5. After installation, remove the transportation clasp attached to the large openings. **(Refer to figure 6)**

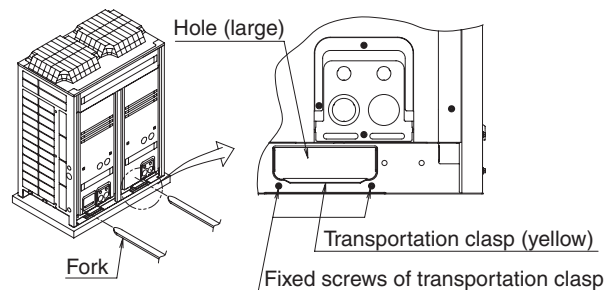

figure 5

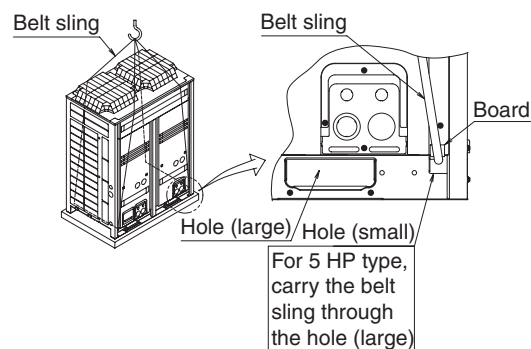

figure 6



Note: Apply a filler cloth on a fork to prevent coating of the bottom frame from coming off and rust from occurring when bringing in the unit with anti-corrosion treatment type using a forklift.

2.5 Placing the Unit

- Make sure the unit is installed level on a sufficiently strong base to prevent vibration and noise. (Refer to figure 7)
- The base should be bigger around than the width of the unit's legs (66 mm), and should support the unit. (Refer to figure 8)
If protective rubber is to be attached, attach it to the whole face of the base.
- The height of the base should be at least 150mm from the floor.
- Secure the unit to its base using foundation bolts. (Use four commercially available M12-type foundation bolts, nuts, and washers.)
- The foundation bolts should be inserted 20 mm.

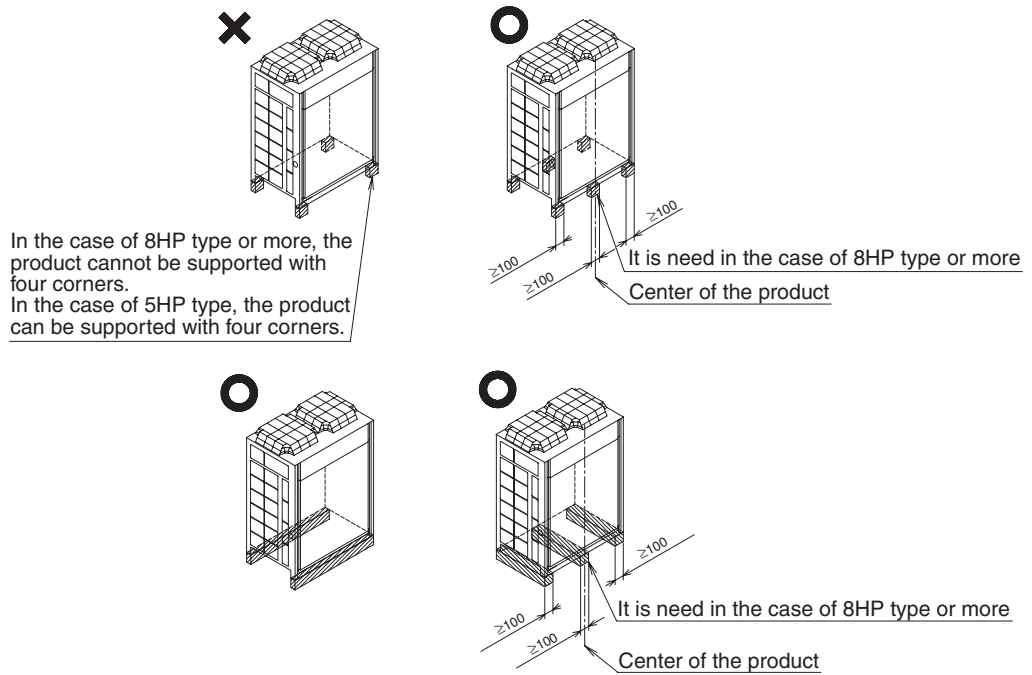
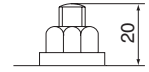

figure 7

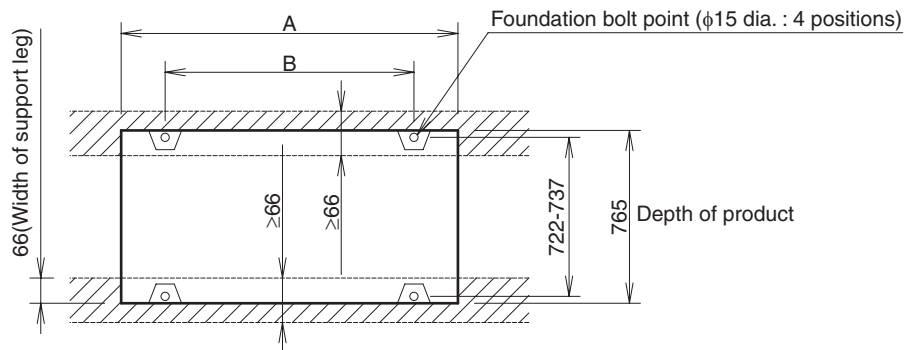

figure 8

Model	A	B
5HP type	635	497
8 · 10HP type	930	792
12 · 14 · 16 · 18HP type	1240	1102



Note:

- There are restrictions on the refrigerant pipe connecting order between outdoor unit in the case of the multi system.
See the Note in "2-2-1 Combination" for detail.
- When installing on a roof, make sure the roof floor is strong enough and be sure to water-proof all work.
- Make sure the area around the machine drains properly by setting up drainage grooves around the foundation.
Drain water is sometimes discharged from the outdoor unit when it is running.
- For anti-corrosion type use nuts with resin washers. If the paint on nut connections comes off, the anti-corrosion effect may decrease.

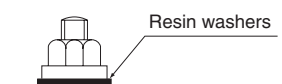

2.6 Refrigerant Piping



- Note:**
- All field piping must be installed by a licensed refrigeration technician and must comply with relevant local and national regulations.
 - After piping work is complete, do not under any circumstances open the shutoff valve until “2-7. Field Wiring” and “2-10. Checking of Device and Installation Conditions” are complete.
 - Do not use flux when brazing the refrigerant piping. Use the phosphor copper brazing filler metal (BCuP-2: JIS Z 3264/B-Cu93P-710/795: ISO 3677) which does not require flux. (Flux has extremely harmful influence on refrigerant piping systems. For instance, if the chlorine based flux is used, it will cause pipe corrosion or, in particular, if the flux contains fluorine, it will damage the refrigerant oil.)

2.6.1 Selection of Piping Material and Refrigerant Branching Kit

- Use only pipes which are clean inside and outside and which do not accumulate harmful sulfur, oxidants, dirt, cutting oils, moisture, or other contamination. (Foreign materials inside pipes including oils for fabrication must be 30mg/10m or less.)
- Use the following items for the refrigerant piping.

Material: Jointless phosphor-deoxidized copper pipe

Size: See “2-6-5 Example of connection” to determine the correct size.

Thickness: Select a thickness for the refrigerant piping which complies with national and local laws.

For R-410A, the design pressure is 4.0 MPa (40-bar).

The minimum thickness of piping according to Japan’s High-Pressure Gas Safety Law (as of January 2003) is shown below.

Temper grade (O type, 1/2H type) in the table indicate the material types specified in JIS H 3300.

(unit: mm)

Temper grade	O type			
outer diameter	φ6.4	φ9.5	φ12.7	φ15.9
smallest thickness	0.80	0.80	0.80	0.99

(unit: mm)

Temper grade	1/2H type							
outer diameter	φ19.1	φ22.2	φ25.4	φ28.6	φ31.8	φ34.9	φ38.1	φ41.3
smallest thickness	0.80	0.80	0.88	0.99	1.10	1.21	1.32	1.43

- For piping work, follow the maximum tolerated length, difference in height, and length after a branch indicated in the “2-6-5 Example of connection”.
- A refrigerant branching kit (sold separately) is needed for piping branches and connection of piping between outdoor unit (in case of multi system).
Use only separately sold items selected specifically according to the refrigerant branch kit selection in the “2-6-5 Example of connection”.

2.6.2 Protection Against Contamination when Installing Pipes

Protect the piping to prevent moisture, dirt, dust, etc. from entering the piping.

Place	Installation period	Protection method
Outdoor	More than a month	Pinch the pipe
	Less than a month	Pinch or tape the pipe
Indoor	Regardless of the period	



- Note:** Exercise special caution to prevent dirt or dust when passing piping through holes in walls and when passing pipe edges to the exterior.

2.6.3 Pipe Connection

- Be sure to perform nitrogen permutation or nitrogen blow when brazing. (Refer to figure 10) Brazing without performing nitrogen permutation or nitrogen blow into the piping will create large quantities of oxidized film on the inside of the pipes, adversely affecting valves and compressors in the refrigerating system and preventing normal operation.

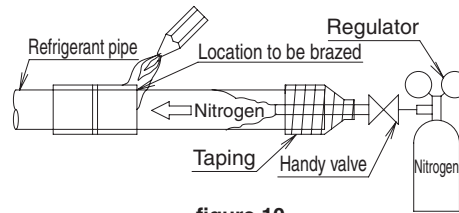

figure 10

- The pressure regulator for the nitrogen released when doing the brazing should be set to 0.02 MPa (about 0.2kg/cm²:Enough to feel a slight breeze on your cheek).



Note: Do not use anti-oxidants when brazing the pipe joints. Residue can clog pipes and break equipment.

2.6.4 Connecting the Refrigerant Piping

- Direction to bring out the pipes
The local interunit piping can be connected either forward or to the sides (taken out through the bottom) as shown in the figure 11.
(When passing out through the bottom, use the knock hole in the bottom frame.)

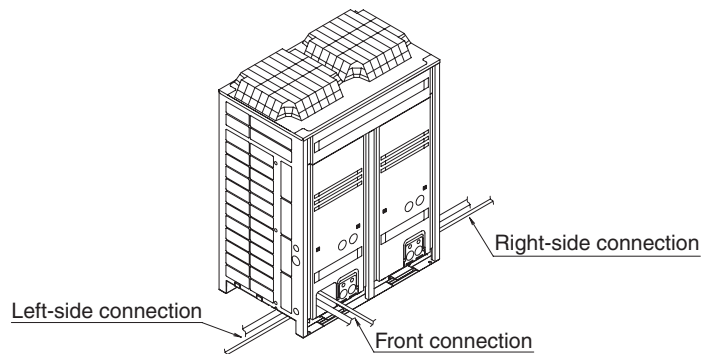
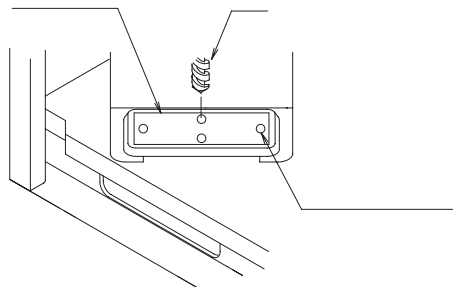

figure 11

Precautions when knocking out knock holes

- Open knock hole in the base frame by drilling the 4 concave around it with a 6mm bit. (Refer to figure 12)



- Be sure to avoid damaging the casing
- After knocking out the holes, we recommend you remove any burrs and paint them using the repair paint to prevent rusting.
- When passing electrical wiring through the knock holes, protect the wiring with a conduit or bushings, making sure not to damage the wiring.

2. Removing Pinch Piping

- When connecting refrigerant piping to an outdoor unit, remove the pinch piping. (**Refer to figure 13**)
- Pinch piping should be removed using the procedure in the figure 13.

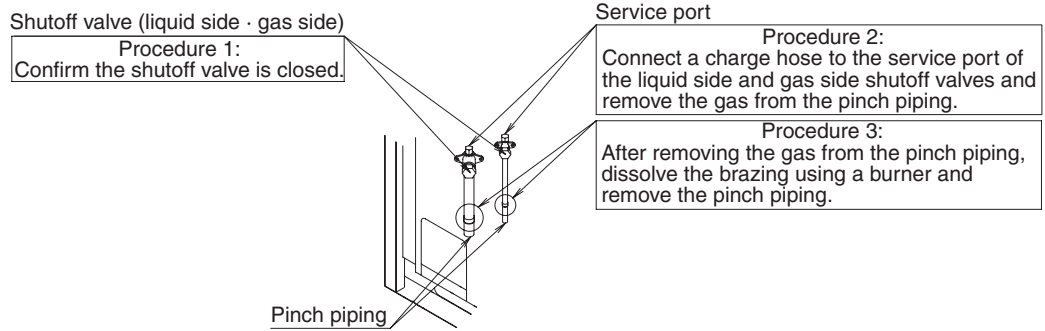

figure 13



Caution: After removing the gas, remove the pinch piping. Any gas remaining inside may blow off the pinch piping when you dissolve the brazing, causing damage.

3. Connecting refrigerant piping to outdoor units

<In case of single system: 5-18HP type>

If connected to the front

Remove the shutoff valve cover to connect.

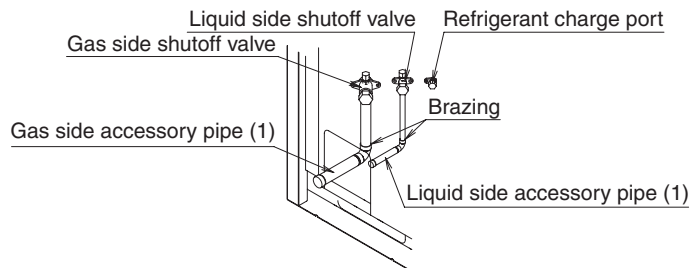

When connected at lateral side (bottom)

Remove the knock hole on the bottom frame and route the piping under the bottom frame.

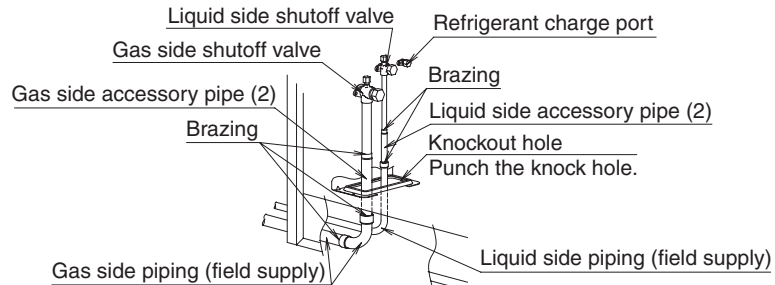
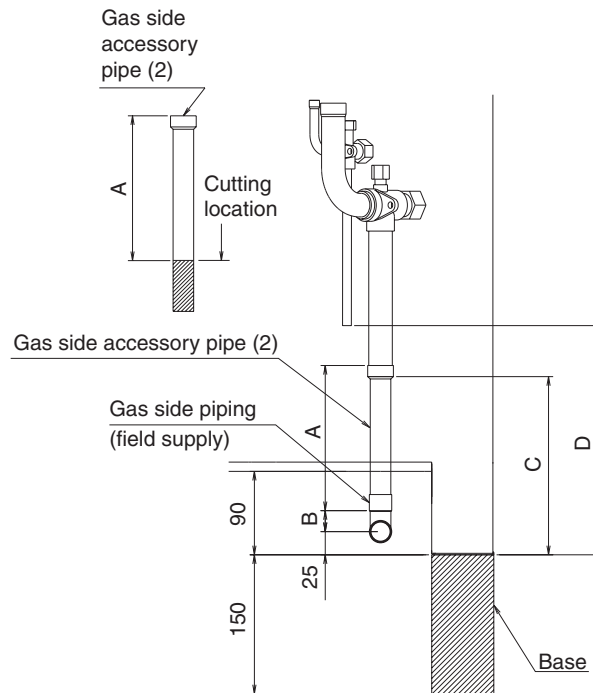

figure 14

Processing the Gas side accessory pipe (2)

Only in case of connecting at lateral side, cut the Gas side accessory pipe (2) referring the figure below.



(mm)

Model	A	B	C	D
5HP type	166	16	199	246
8HP type	156	17	188	247
10HP type	156	23	192	247
12HP type	150	29	192	247
14·16·18HP type	150	29	192	251

<In case of multi system: RXYQ20-54P(E)>

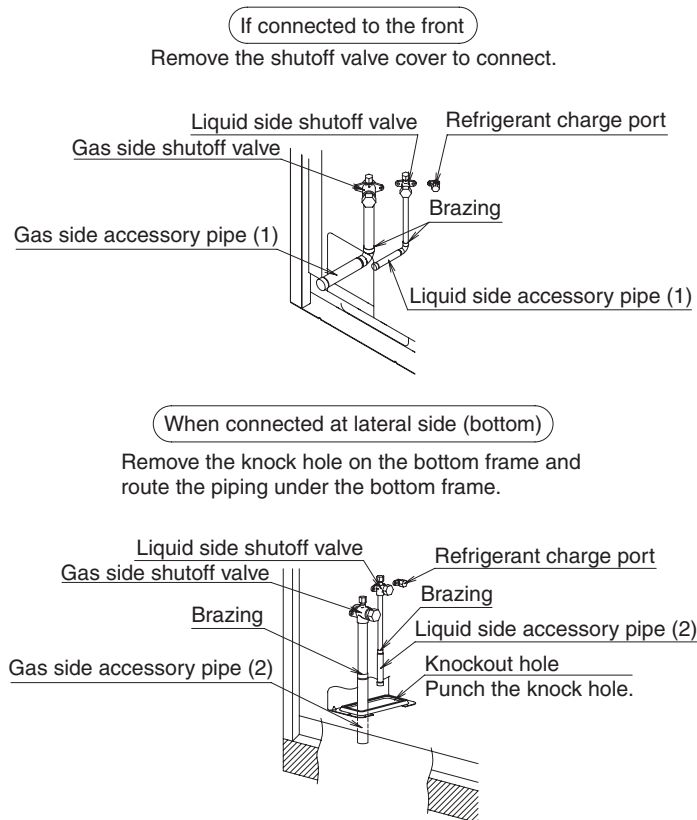

figure 15

**Note:** <Connecting Refrigerant Piping>

- When connecting the piping on site, be sure to use the accessory piping.
- Make sure the onsite piping does not come into contact with other piping or the bottom frame or side panels of the unit.

<Multi Systems>

- The 5HP type cannot be used as an independent unit in a multi system.
- The Outdoor unit multi connection piping kit (sold separately) is needed when connecting piping between outdoor units.
Refer to the installation manual that comes with the kit when doing this piping work.

4. Precautions when connecting piping between outdoor units (In case of multi system)
The Outdoor unit multi connection piping kit (sold separately) is needed to connect piping between outdoor units in multi system. Only proceed with piping work after considering the limitations on installation listed here and in “5. Branching the refrigerant piping”, always referring to the kit’s installation manual.

(1) The piping between outdoor units must be installed level (Pattern 1) or with a rise (Pattern 2). Otherwise oil may pool in the pipes.

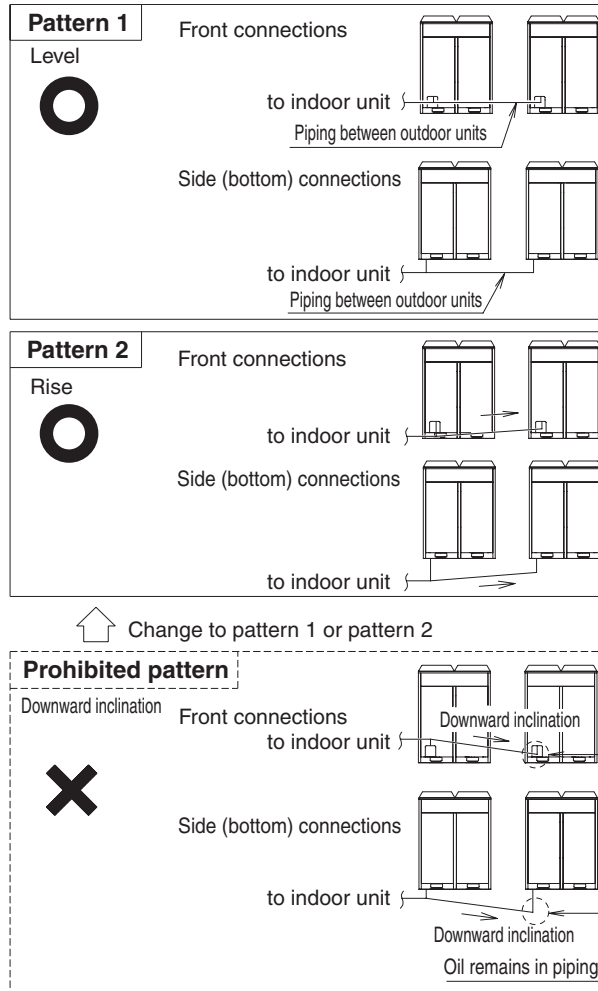

(2) To avoid the risk of oil detention in the stopping unit, always connect the shutoff valve and the piping between outdoor units as shown in the figure A or figure B.

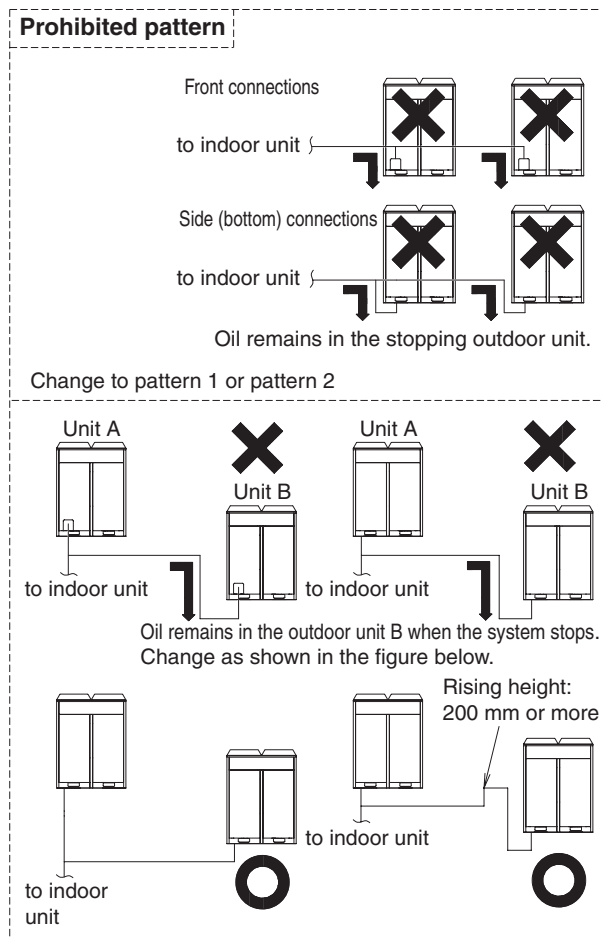
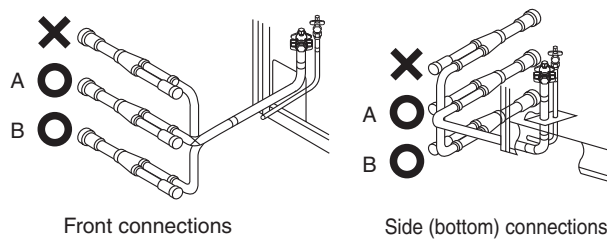

(3) If the piping length between the outdoor units exceeds 2 m, create a rise of 200 mm or more in the gas line under a length of 2 m from the outdoor unit multi connection piping kit.

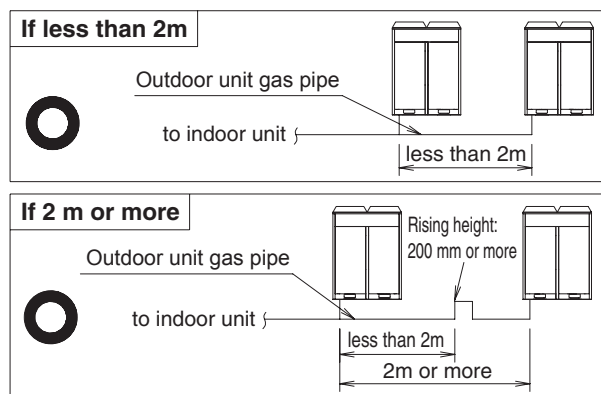

5. Branching the refrigerant piping

Heed the restrictions below when installing the refrigerant branching kit and read the installation instruction manual with the kit.

(Improper installation could lead to malfunctioning or breakdown of the outdoor unit.)

<REFNET joint>

Install the REFNET joint so it splits horizontally or vertically.

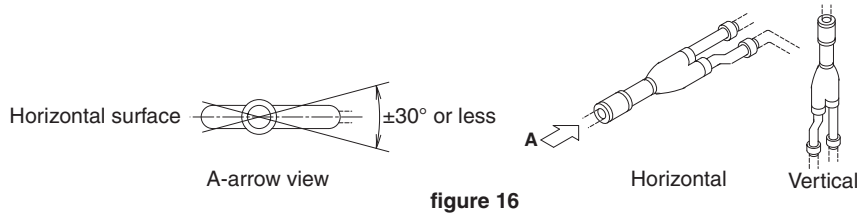

figure 16

<REFNET header>

Install the REFNET header so it splits horizontally.

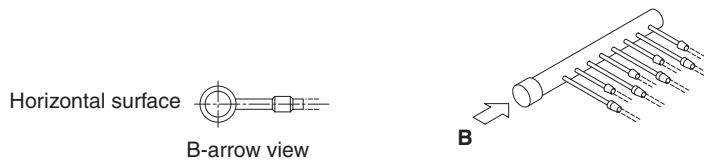

figure 17

<Outdoor unit multi connection piping kit>

- Install the joint horizontally so that the attached warning label faces straight up, and the tilt is within $\pm 15^\circ$. (Refer to figure 18-1)
Do not install vertically. (Refer to figure 18-2)
- Maintain a straight portion of 500 mm or more until the split of the joint without wrapping any onsite piping around this area.
Over 500 mm of straight area can be maintained by connecting at least 120 mm of onsite pipe (straight) to the joint. (Refer to figure 18-3)

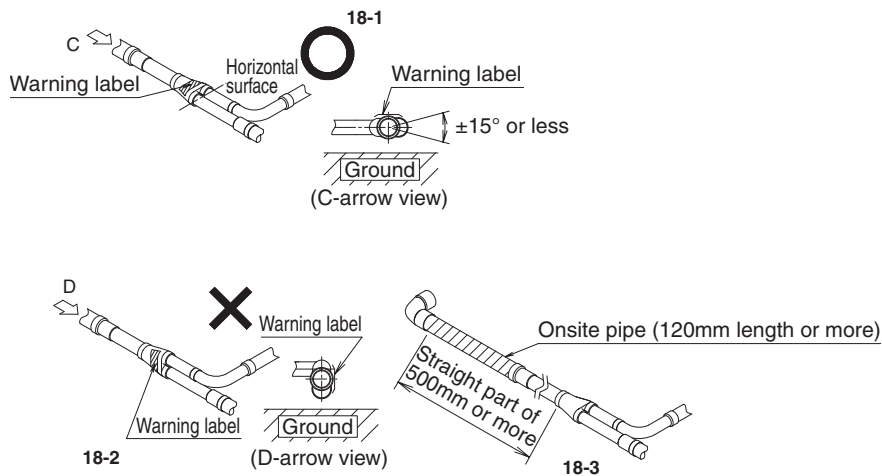
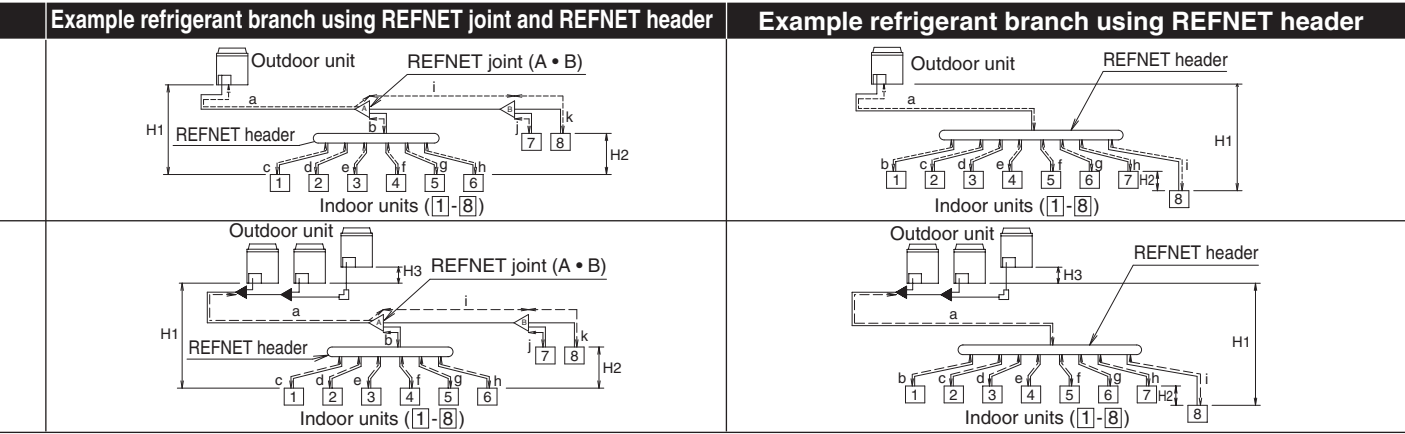

figure 18

2.6.5 EXAMPLE OF CONNECTION

<p>Example of connection (Connection of 8 indoor units)</p> <p>(*1) " ← " indicate the Outdoor unit multi connection piping kit</p> <p>(*2) In case of multi outdoor system, re-read to the first Outdoor unit multi connection piping kit as seen from the indoor unit.</p>		<p>Single outdoor system</p>	<p>Example refrigerant branch using REFNET joint</p>	Exam																													
<p>Multi outdoor system</p>		<p>Actual pipe length</p> <p>Equivalent length</p> <p>Total extension length</p> <p>Actual pipe length Equivalent length</p>	<p>Pipe length between outdoor (*2) and indoor units ≤ 165m Example unit [8] : a + b + c + d + e + f + g + p ≤ 165m</p> <p>Equivalent pipe length between outdoor (*2) and indoor units ≤ 190m (assume equivalent length)</p> <p>Total pipe length from outdoor unit (*2) to all indoor units ≤ 1000m</p> <p>Pipe length between outdoor unit and Outdoor unit multi connection piping kit ≤ 10m, Equivalent length</p>	Exam																													
Maximum allowable length	Between outdoor (*2) and indoor units	Actual pipe length	Pipe length between outdoor (*2) and indoor units ≤ 165m Example unit [8] : a + b + c + d + e + f + g + p ≤ 165m	Exam																													
	Between outdoor unit and Outdoor unit multi connection piping kit (Only for multi system)	Equivalent length	Equivalent pipe length between outdoor (*2) and indoor units ≤ 190m (assume equivalent length)																														
		Total extension length	Total pipe length from outdoor unit (*2) to all indoor units ≤ 1000m																														
Allowable height length	Between outdoor and indoor units	Difference in height	Pipe length between outdoor unit and Outdoor unit multi connection piping kit ≤ 10m, Equivalent length																														
	Between indoor and indoor units	Difference in height	Difference in height between outdoor and indoor units (H1) ≤ 50m (≤ 90m if the outdoor unit is connected to the indoor unit via a REFNET joint)																														
	Between outdoor and outdoor units	Difference in height	Difference in height between indoor units (H2) ≤ 15m Difference in height between outdoor unit (H3) ≤ 5m																														
Allowable length after the branch		Actual pipe length	Pipe length from first refrigerant branch kit (either REFNET joint or REFNET header) to indoor units ≤ 40m Example unit [8] : b + c + d + e + f + g + p ≤ 40m	Exam																													
<p>Refrigerant branch kit selection</p> <p>Refrigerant branch kits can only be used with R-410A.</p> <p>⚠ When multi outdoor system are installed, be sure to use the special separately sold Outdoor unit multi connection piping kit. The table at right shows how to select the proper kit.</p>		<p>How to select the REFNET joint</p> <ul style="list-style-type: none"> When using REFNET joint at the first branch counted from the outdoor unit side. Choose from the following table in accordance with the outdoor unit capacity type. (Example: REFNET joint A) <table border="1"> <thead> <tr> <th>Outdoor unit capacity type</th> <th>Refrigerant branch kit name</th> </tr> </thead> <tbody> <tr> <td>5HP type</td> <td>KHRP26A22T</td> </tr> <tr> <td>8, 10HP type</td> <td>KHRP26A33T</td> </tr> <tr> <td>12~22HP type</td> <td>KHRP26A72T</td> </tr> <tr> <td>24HP type~</td> <td>KHRP26A73T + KHRP26A74T</td> </tr> </tbody> </table> <ul style="list-style-type: none"> Choose the REFNET joints other than that for the first branch from the following table in accordance with the capacity index of all the indoor units connected below the REFNET joint. <table border="1"> <thead> <tr> <th>Indoor unit total capacity index</th> <th>Refrigerant branch kit name</th> </tr> </thead> <tbody> <tr> <td>< 200</td> <td>KHRP26A22T</td> </tr> <tr> <td>200 ≤ x < 290</td> <td>KHRP26A33T</td> </tr> <tr> <td>290 ≤ x < 640</td> <td>KHRP26A72T</td> </tr> <tr> <td>640 ≤</td> <td>KHRP26A73T + KHRP26A74T</td> </tr> </tbody> </table>			Outdoor unit capacity type	Refrigerant branch kit name	5HP type	KHRP26A22T	8, 10HP type	KHRP26A33T	12~22HP type	KHRP26A72T	24HP type~	KHRP26A73T + KHRP26A74T	Indoor unit total capacity index	Refrigerant branch kit name	< 200	KHRP26A22T	200 ≤ x < 290	KHRP26A33T	290 ≤ x < 640	KHRP26A72T	640 ≤	KHRP26A73T + KHRP26A74T									
Outdoor unit capacity type	Refrigerant branch kit name																																
5HP type	KHRP26A22T																																
8, 10HP type	KHRP26A33T																																
12~22HP type	KHRP26A72T																																
24HP type~	KHRP26A73T + KHRP26A74T																																
Indoor unit total capacity index	Refrigerant branch kit name																																
< 200	KHRP26A22T																																
200 ≤ x < 290	KHRP26A33T																																
290 ≤ x < 640	KHRP26A72T																																
640 ≤	KHRP26A73T + KHRP26A74T																																
<p>Example for indoor units connected downstream</p>		<p>Example REFNET joint C: indoor units [3]+[4]+[5]+[6]+[7]+[8]</p>																															
<p>Pipe size selection</p> <p>⚠ Caution The thickness of the pipes in the table shows the requirements of Japanese High Pressure Gas Control law. (As of Jan. 2003) The thickness and material shall be selected in accordance with local code.</p> <p>For the multi outdoor unit system, select in accordance with the following figure.</p>		<p>Temper grade and wall thickness for pipes. (Temper grade, O type and 1/2H type indicate the material types specified in JIS H 3300.) (Unit:mm)</p> <table border="1"> <thead> <tr> <th>Copper tube O.D.</th> <th>Copper tube W.T. (Minimum requirement)</th> <th>Temper grade</th> </tr> </thead> <tbody> <tr><td>φ6.4</td><td>0.80</td><td rowspan="4">O type</td></tr> <tr><td>φ9.5</td><td>0.80</td></tr> <tr><td>φ12.7</td><td>0.80</td></tr> <tr><td>φ15.9</td><td>0.99</td></tr> <tr><td>φ19.1</td><td>0.80</td><td rowspan="7">1/2H type</td></tr> <tr><td>φ22.2</td><td>0.80</td></tr> <tr><td>φ25.4</td><td>0.88</td></tr> <tr><td>φ28.6</td><td>0.99</td></tr> <tr><td>φ31.8</td><td>1.10</td></tr> <tr><td>φ34.9</td><td>1.21</td></tr> <tr><td>φ38.1</td><td>1.32</td></tr> <tr><td>φ41.3</td><td>1.43</td></tr> </tbody> </table>			Copper tube O.D.	Copper tube W.T. (Minimum requirement)	Temper grade	φ6.4	0.80	O type	φ9.5	0.80	φ12.7	0.80	φ15.9	0.99	φ19.1	0.80	1/2H type	φ22.2	0.80	φ25.4	0.88	φ28.6	0.99	φ31.8	1.10	φ34.9	1.21	φ38.1	1.32	φ41.3	1.43
Copper tube O.D.	Copper tube W.T. (Minimum requirement)	Temper grade																															
φ6.4	0.80	O type																															
φ9.5	0.80																																
φ12.7	0.80																																
φ15.9	0.99																																
φ19.1	0.80	1/2H type																															
φ22.2	0.80																																
φ25.4	0.88																																
φ28.6	0.99																																
φ31.8	1.10																																
φ34.9	1.21																																
φ38.1	1.32																																
φ41.3	1.43																																
<p>How to calculate the additional refrigerant to be charged</p> <p>Additional refrigerant to be charged R (kg) (R should be rounded off in units of 0.1Kg.)</p>		$R = \left(\frac{\text{Total length (m) of liquid piping size at } \phi 22.2}{\text{Total length (m) of liquid piping size at } \phi 19.1} \right) \times 0.37 + \left(\frac{\text{Total length (m) of liquid piping size at } \phi 19.1}{\text{Total length (m) of liquid piping size at } \phi 15.9} \right) \times 0.26 + \left(\frac{\text{Total length (m) of liquid piping size at } \phi 15.9}{\text{Total length (m) of liquid piping size at } \phi 6.4} \right) \times 0.18 + \left(\frac{\text{Total length (m) of liquid piping size at } \phi 6.4}{\text{Total length (m) of liquid piping size at } \phi 6.4} \right) \times 0.022$																															



Example unit 6 : a + b + h ≤ 165m, unit 8 : a + i + k ≤ 165m
 Example unit 8 : a + i ≤ 165m
 (Note: The equivalent pipe length of REFNET joint to be 0.5m, that of REFNET header to be 1m, calculation purposes) (See Note 1 - Next page)

≤ 10m, Equivalent length between outdoor unit and Outdoor unit multi connection piping kit ≤ 13m
 if the outdoor unit is below)
 r ≤ 10m (Equivalent length: ≤ 13m)
 s ≤ 10m (Equivalent length: ≤ 13m)
 t ≤ 10m (Equivalent length: ≤ 13m)
 (header) to indoor unit ≤ 40m (See Note 2 - Next page)
 Example unit 6 : b + h ≤ 40m, unit 8 : i + k ≤ 40m
 Example unit 8 : i ≤ 40m

side.
 y type.

Refrigerant branch kit name

6A22T
6A33T
6A72T
6A73T + KHRP26M73TP

Following table in accordance with the total

Refrigerant branch kit name

6A22T
6A33T
6A72T
6A73T + KHRP26M73TP

How to select the REFNET header

- Choose from the following table in accordance with the total capacity index of all the indoor units connected below the REFNET header.
- Note: 250 type indoor unit cannot be connected below the REFNET header.

Indoor unit total capacity index	Refrigerant branch kit name
< 200	KHRP26M22H (Max. 4 branch)
200 ≤ x < 290	KHRP26M33H (Max. 8 branch)
290 ≤ x < 640	KHRP26M72H (Max. 8 branch) (See Note 3 - Next page)
640 ≤	KHRP26M73H (Max. 8 branch) + KHRP26M73HP

How to select the Outdoor unit multi connection piping kit (This is required when the system is multi outdoor unit system.)

- Choose from the following table in accordance with the number of outdoor units.

Number of outdoor units	Connection piping kit name
2 units	BHFP22P100
3 units	BHFP22P151

Example REFNET joint B: indoor units 7+8
 Example REFNET header: indoor units 1+2+3+4+5+6
 Example REFNET header: indoor units 1+2+3+4+5+6+7+8

Piping between Outdoor unit and first refrigerant branch kit.
 Piping between first Outdoor unit multi connection piping kit and first refrigerant branch kit. (Part A)

- Choose from the following table in accordance with the outdoor unit capacity type.

Piping between Outdoor unit multi connection piping kits. (Part B)

Piping between outdoor unit and Outdoor unit multi connection piping kit. (Part C)

- Choose from the following table in accordance with the total capacity type of all the outdoor units connected above Outdoor unit multi connection piping kit.

(Unit:mm)

Outdoor unit capacity type	Piping size (O.D.)	
	Gas pipe	Liquid pipe
5HP type	φ15.9	φ9.5
8HP type	φ19.1	
10HP type	φ22.2	φ12.7
12~16HP type	φ28.6	
18~22HP type	φ34.9	φ15.9
24HP type	φ41.3	
26~34HP type		φ19.1
36~54HP type		

(See Note 1 - Next page)

Piping between refrigerant branch kits

- Choose from the following table in accordance with the total capacity index of all the indoor units connected below this.
- Do not let the connection piping exceed the main refrigerant piping size. (Unit:mm)

Indoor unit total capacity index	Piping size (O.D.)	
	Gas pipe	Liquid pipe
< 150	φ15.9	φ9.5
150 ≤ x < 200	φ19.1	
200 ≤ x < 290	φ22.2	
290 ≤ x < 420	φ28.6	φ12.7
420 ≤ x < 640	φ34.9	
640 ≤ x < 920	φ41.3	φ19.1
920 ≤	φ41.3	

Piping between refrigerant branch kit and indoor unit

- Match to the size of the connection piping on the indoor unit. (Unit:mm)

Indoor unit capacity type	Piping size (O.D.)	
	Gas pipe	Liquid pipe
20 · 25 · 32 · 40? · 50 type	φ12.7	φ6.4
63 · 80 · 100 · 125 type	φ15.9	
200 type	φ19.1	φ9.5
250 type	φ22.2	

Example for refrigerant branch using REFNET joint and REFNET header

In case the outdoor unit is RXYQ34 type and the piping lengths are as at right

a: φ19.1 × 30m	d: φ9.5 × 10m	g: φ 6.4 × 10m	j: φ 6.4 × 10m
b: φ15.9 × 10m	e: φ9.5 × 10m	h: φ 6.4 × 20m	k: φ 6.4 × 9m
c: φ 9.5 × 10m	f: φ9.5 × 10m	i: φ12.7 × 10m	

$$R = \frac{30 \times 0.26}{a} + \frac{10 \times 0.18}{b} + \frac{10 \times 0.12}{i} + \frac{40 \times 0.059}{c+d+e+f} + \frac{49 \times 0.022}{g+h+j+k} = 14.238$$

14.2 kg

2.6.6 EXAMPLE OF CONNECTION)

*Note 1

When the equivalent pipe length between outdoor and indoor units is 90m or more, the size of main pipe must be increased. Depending on the length of the piping, the capacity may drop, but even in such case it is able to increase the capacity.

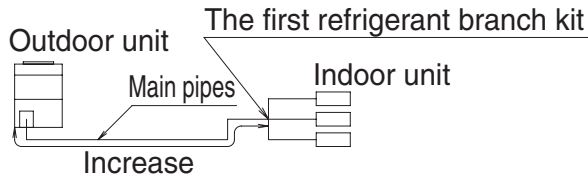

figure 9

■ Diameter of above case

Model	Gas	Liquid
RX(Y)Q5 Type	φ19.1	Not Increased
RX(Y)Q8 Type	φ22.2	φ12.7
RX(Y)Q10 Type	φ25.4*	φ12.7
RX(Y)Q12 Type	Not Increased	φ15.9
RX(Y)Q14 Type	Not Increased	φ15.9
RX(Y)Q16 Type	φ31.8*	φ15.9
RX(Y)Q18 Type	φ31.8*	φ19.1

Model	Gas	Liquid
RX(Y)Q20 Type	φ31.8*	φ19.1
RX(Y)Q22 Type	φ31.8*	φ19.1
RX(Y)Q24 Type	Not Increased	φ19.1
RX(Y)Q26 Type	φ38.1*	φ22.2
RX(Y)Q28 Type	φ38.1*	φ22.2
RX(Y)Q30 Type	φ38.1*	φ22.2
RX(Y)Q32 Type	φ38.1*	φ22.2

*Note 2

Allowable length after the first refrigerant branch kit to indoor units is 40 m or less, however it can be extended under the following conditions.

Required Conditions	Example Drawing
1. It is necessary to increase the pipe size between the first branch kit and the final branch kit. (Reducers must be procured on site) However, the pipes that are same pipe size with main pipe must not be increased.	[8] $b+c+d+e+f+g+p \leq 90$ m increase the pipe size of b, c, d, e,
2. For calculation of Total extension length, the actual length of above pipes must be doubled. (except main pipe and the pipes that are not increased)	$a+b \times 2+c \times 2+d \times 2+e \times 2+f \times 2+g \times 2+h+i+j+k+l+m+n+p \leq 1000$ m
3. Indoor unit to the nearest branch kit ≤ 40 m	$h, i, j, \dots, p \leq 40$ m
4. The difference between [Outdoor unit to the farthest indoor unit] and [Outdoor unit to the nearest indoor unit] ≤ 40 m	The farthest indoor unit [8] The nearest indoor unit [1] $(a+b+c+d+e+f+g+p) - (a+h) \leq 40$ m

*If available on the site, use this size. Otherwise it can not be increased.

*Note 3

If the pipe size above the REFNET header is φ34.9 or more, KHRP26M73HP is required.

of main pipes (both gas-side and liquid-side) must be increased.
to increase the size of main pipes.

Model	Gas	Liquid
RX(Y)Q34 Type	φ38.1*	φ22.2
RX(Y)Q36 Type	Not Increased	φ22.2
RX(Y)Q38 Type	Not Increased	φ22.2
RX(Y)Q40 Type	Not Increased	φ22.2
RX(Y)Q42 Type	Not Increased	φ22.2
RX(Y)Q44 Type	Not Increased	φ22.2
RX(Y)Q46 Type	Not Increased	φ22.2

Model	Gas	Liquid
RX(Y)Q48 Type	Not Increased	φ22.2
RX(Y)Q50 Type	Not Increased	φ22.2
RX(Y)Q52 Type	Not Increased	φ22.2
RX(Y)Q54 Type	Not Increased	φ22.2

*If available on the site, use this size.
Otherwise, it can not be increased.

be extended up to **90 m** if all the following conditions are satisfied. (In case of “ **Branch with REFNET joint** ”)

Drawings	
90 m c, d, e, f, g	Increase the pipe size as follows φ 9.5 → φ12.7 φ15.9 → φ19.1 φ22.2 → φ25.4* φ34.9 → φ38.1* φ12.7 → φ15.9 φ19.1 → φ22.2 φ28.6 → φ31.8*
+f×2+g×2 1000 m	<p style="text-align: center;">Indoor units (1 - 8)</p>
a+h) ≤ 40 m	

2.7 Field Wiring



Caution:

- All field wiring and components must be installed by a licensed electrician and must comply with relevant local and national regulations.
- Be sure to use a dedicated power circuit. Never use a power supply shared by another appliance.
- Never install a phase advancing capacitor. As this unit is equipped with an inverter, installing a phase advancing capacitor will not only deteriorate power factor improvement effect, but also may cause capacitor abnormal heating accident due to high-frequency waves.
- Only proceed with wiring work after blocking off all power.
- Always ground wires in accordance with relevant local and national regulations.
- This machine includes an inverter device. Connect earth and leave charge to eliminate the impact on other devices by reducing noise generated from the inverter device and to prevent leaked current from being charged in the outer hull of the product.
- Do not connect the ground wire to gas pipes, sewage pipes, lightning rods, or telephone ground wires.

Gas pipes: can explode or catch fire if there is a gas leak.

Sewage pipes: no grounding effect is possible if hard plastic piping is used.

Telephone ground wires and lightning rods: dangerous when struck by lightning due to abnormal rise in electrical potential in the grounding.

- Be sure to install an earth leakage circuit breaker.
This unit uses an inverter, so install the earth leakage circuit breaker that be capable of handling high harmonics in order to prevent malfunctioning of the earth leakage circuit breaker itself.
- Earth leakage circuit breaker which are especially for protecting ground-faults should be used in conjunction with main switch or fuse for use with wiring.



Note:

- Electrical wiring must be done in accordance with the wiring diagrams and the description herein.
- Do not operate until refrigerant piping work is completed.
(If operated before complete the piping work, the compressor may be broken down.)
- Never remove thermistor, sensor or etc. when connecting power wiring and transmission wiring.
(If operated with thermistor, sensor or etc. removed, the compressor may be broken down.)
- This product have reversed phase protection detector that only works when the power is turned on. If there exists black out or the power goes on and off which the product is operating, attach a reversed phase protection circuit locally. Running the product in reversed phase may break the compressor and other parts.
- Attach the power wire securely. Introducing power with a missing N-phase or with a mistaken N-phase will break the unit.
- Never connect the power supply in reversed phase.
The unit can not operate normally in reversed phase.
If you connect in reversed phase, replace two of the three phases.
- Make sure the electrical unbalance ratio is no greater than 2%. If it is larger than this, the unit's life span will be reduced.
If the ratio exceeds 4%, the unit will shut down and an malfunction code will be displayed on the indoor remote control.
- Connect the wire securely using designated wire and fix it with attached clamp without applying external pressure on the terminal parts (terminal for power wiring, terminal for transmission wiring and earth terminal).

2.7.1 Power Circuit, Safety Device, and Cable Requirements

- A power circuit (see the following table) must be provided for connection of the unit. This circuit must be protected with the required safety devices, i.e. a main switch, a slow blow fuse on each phase and an earth leakage circuit breaker.
- When using residual current operated circuit breakers, be sure to use a high-speed type (1 second or less) 200mA rated residual operating current.
- Use copper conductors only.
- Use insulated wire for the power cord.
- Select the power supply cable type and size in accordance with relevant local and national regulations.
- Specifications for local wiring are in compliance with IEC60245.
- Use wire type H05VV when protected pipes are used.
Use wire type H07RN-F when protected pipes are not used.

	Phase and frequency	Voltage	Minimum circuit amp.	Recommended fuses
RXYQ5PYL	φ 3, 60Hz	380V	11.9A	15A
RXYQ8PYL	φ 3, 60Hz	380V	18.5A	25A
RXYQ10PYL	φ 3, 60Hz	380V	22.8A	30A
RXYQ12PYL	φ 3, 60Hz	380V	23.9A	30A
RXYQ14PYL	φ 3, 60Hz	380V	33.9A	40A
RXYQ16PYL	φ 3, 60Hz	380V	33.9A	40A
RXYQ18PYL	φ 3, 60Hz	380V	34.9A	40A
RXYQ20PYL	φ 3, 60Hz	380V	42.4A	50A
RXYQ22PYL	φ 3, 60Hz	380V	46.7A	60A
RXYQ24PYL	φ 3, 60Hz	380V	52.4A	60A
RXYQ26PYL	φ 3, 60Hz	380V	53.4A	60A
RXYQ28PYL	φ 3, 60Hz	380V	57.7A	70A
RXYQ30PYL	φ 3, 60Hz	380V	58.8A	70A
RXYQ32PYL	φ 3, 60Hz	380V	67.8A	80A
RXYQ34PYL	φ 3, 60Hz	380V	68.8A	80A
RXYQ36PYL	φ 3, 60Hz	380V	69.8A	80A
RXYQ38PYL	φ 3, 60Hz	380V	77.3A	90A
RXYQ40PYL	φ 3, 60Hz	380V	86.3A	100A
RXYQ42PYL	φ 3, 60Hz	380V	87.3A	100A
RXYQ44PYL	φ 3, 60Hz	380V	88.3A	100A
RXYQ46PYL	φ 3, 60Hz	380V	92.6A	110A
RXYQ48PYL	φ 3, 60Hz	380V	93.7A	110A
RXYQ50PYL	φ 3, 60Hz	380V	103.7A	120A
RXYQ52PYL	φ 3, 60Hz	380V	103.7A	120A
RXYQ54PYL	φ 3, 60Hz	380V	104.7A	120A



Note: The above table indicates power specifications for standard combinations (see 2-2 Introduction).

If using anything other than the above combinations in a multi system, calculate using the following procedure.

Minimum circuit amp value: add the minimum circuit amp values for each independent unit

Recommended fuse capacity: select the fuse capacity with the next higher value of the calculated minimum circuit amp. multiplied by 1.1.

Ex: Combining the RXYQ30PYL using RXYQ8PYL, RXYQ10PYL, and RXYQ12PYL.

Minimum circuit amp. of the RXYQ8PYL in table above = 18.5 A

Minimum circuit amp. of RXYQ10PYL in table above = 22.8 A

Minimum circuit amp. of RXYQ12PYL in table above = 23.9 A

Accordingly, the minimum circuit amp. of the RXYQ30PYL = 18.5 + 22.8 + 23.9 = 65.2A

Multiplying the result above by 1.1 (65.2 × 1.1) = 71.7 A, so the recommended fuse capacity would be 80 A.

2.7.2 Wiring Connection Example for Whole System

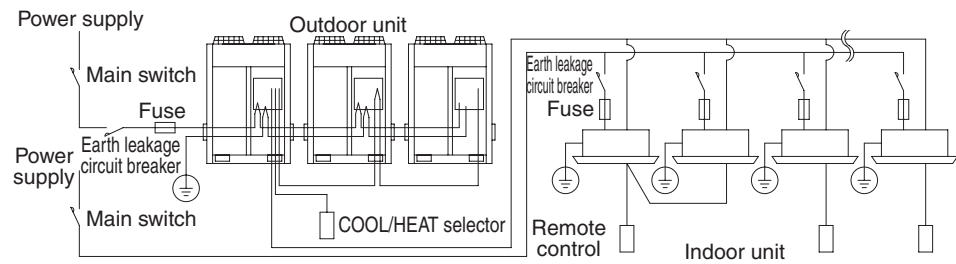

figure 19



Note:

- Make sure the weak electric wiring (i.e. for the remote control, between units, etc.) and the power wiring do not pass near each other, keeping them at least 50 mm apart. Proximity may cause electrical interference, malfunctions, and breakage.
- Be sure to connect the power wiring to the power wiring terminal block and secure it as described in “2-7-5 Power Wiring Connection Procedure”.
- Transmission wiring should be secured as described in “2-7-4 Transmission Wiring Connection Procedure”.
- Secure wiring with clamp such as insulation lock ties to avoid contact with piping.
- Shape the wires to prevent the structure such as the EL. COMPO. BOX lid deforming. And close the cover firmly.
- 5HP type can not compose multi system.

2.7.3 Leading wire Procedure

- The power wiring and ground wiring are passed out from the power wiring hole on the sides, the front (knock hole) or the bottom frame (knock hole) .
- The transmission wiring is passed out from the wiring hole (knock hole) on the front of the unit or from a piping hole.

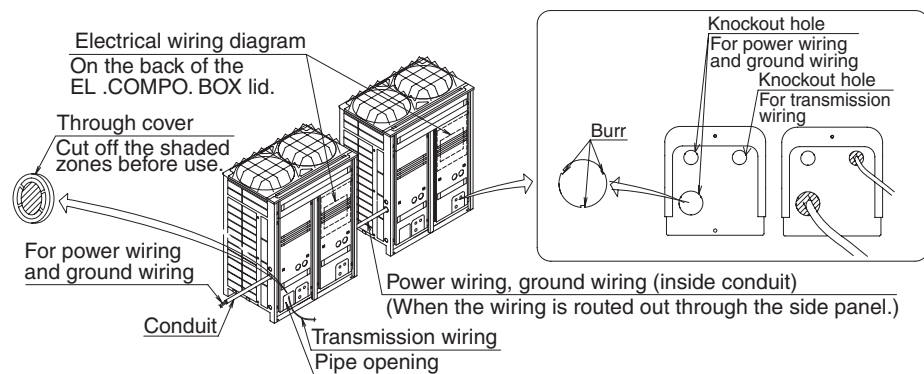

figure 20



Note:

- Open the knock holes with a hammer or the like.
- After knocking out the holes, we recommend you remove any burrs and paint them using the repair paint to prevent rusting.
- When passing wiring through the knock holes, remove burrs around the knock holes and protect the wiring with protective tape. (Refer to figure 20)
- If small animals might enter the unit, block off any gaps (hatching parts in figure 20) with material (field supply).

2.7.4 Transmission Wiring Connection Procedure

- Referring to figure 21, 22 connect the transmission wiring between outdoor unit and indoor unit, outdoor unit and outdoor unit of other system, outdoor unit and outdoor unit of same system (only multi system) or to COOL/HEAT selector.

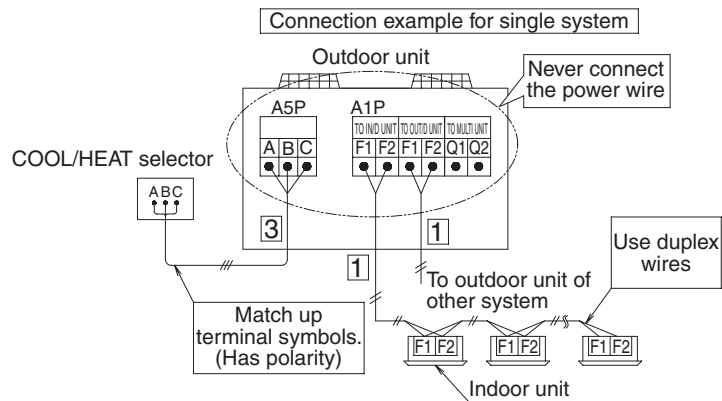

figure 21

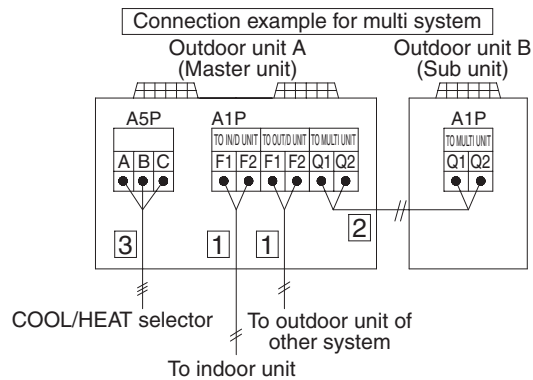

figure 22

- All transmission wiring is to be procured on site. All wiring should use sheathed vinyl cord 0.75-1.25 mm² or cable (duplex). (Triplex only for the COOL/HEAT selector.)
- Transmission wiring (About the symbol 1 ~ 3, see figure 21, 22) should be done within the following limitations.

If they are exceeded, transmission problems may occur.

1 Between outdoor unit and indoor unit

Between outdoor unit and outdoor unit of other systems

- Max. wiring length : 1,000 m
- Max. total wiring length : 2,000 m
- Max. no. of branches : 16

[Note]

No branch is allowed after branch (See figure 23)

Max. no. of outdoor units of other system that can be connected

: 10

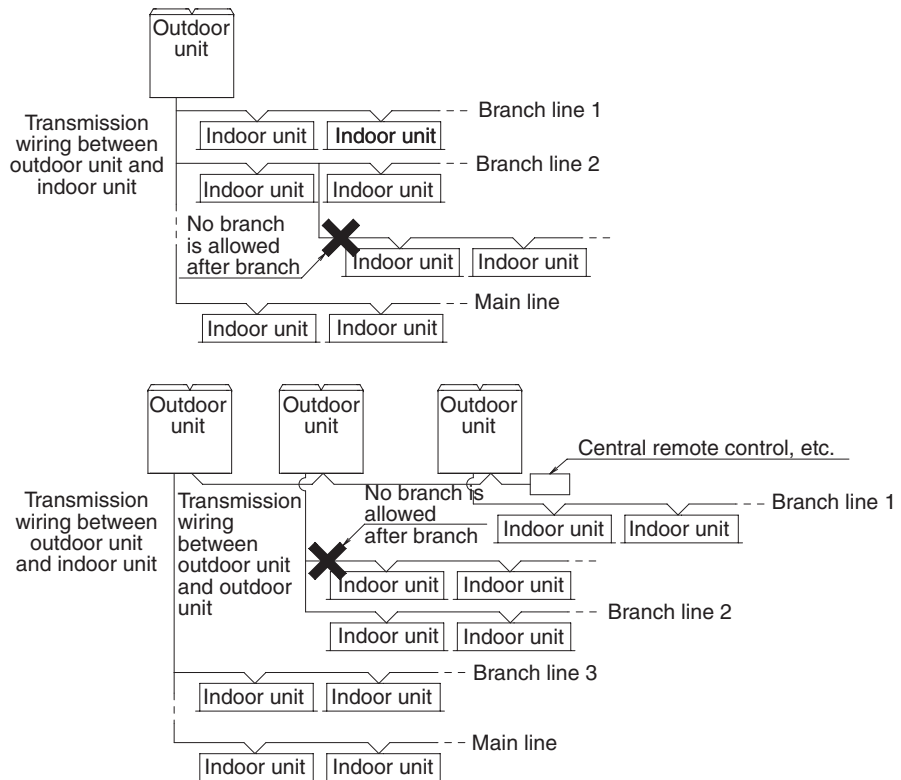

figure 23

- 2 Between outdoor unit and outdoor unit of same system (Only for multi system)
 - Max. wiring length : 30 m
- 3 Transmission wiring to COOL/HEAT selector
 - Max. wiring length : 500 m

- The transmission wiring inside the EL.COMPO.BOX should be secured using the clamp (1) as shown in figure 24.

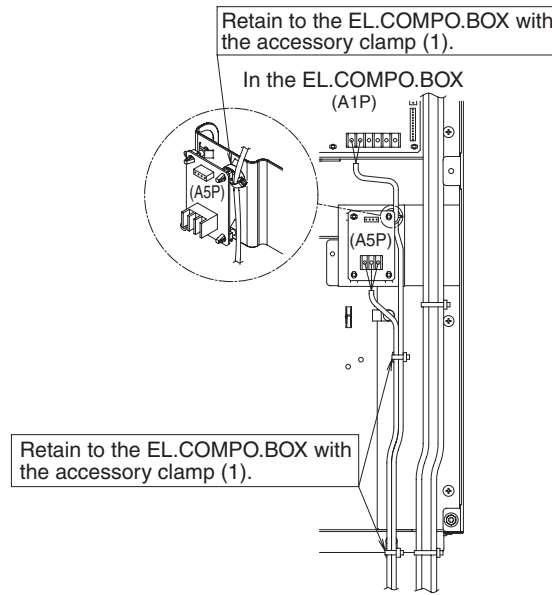

figure 24

- Outside the units, the transmission wiring must be finished simultaneously with the local refrigerant piping, and wound with tape (field supply) as shown in figure 25.

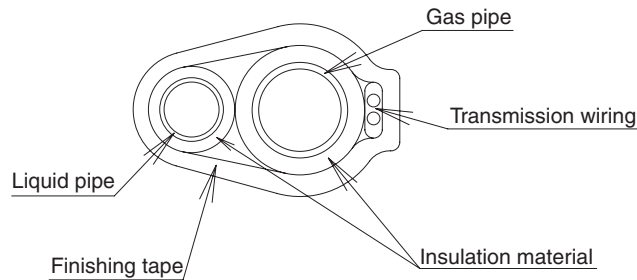

figure 25

- For multi system:
 1. Transmission wiring between outdoor units in the same piping system must be connected to terminals Q1 and Q2 (TO MULTI UNIT). Connecting the wires to the F1, F2 (TO OUT/D UNIT) terminals results in system malfunction.
 2. Wiring to other systems should be connected to terminals F1 and F2 (TO OUT/D UNIT) on the PC-board of the master unit. The outdoor unit that connected transmission wiring to indoor unit is the master unit. The others are sub unit.



Caution:

- Do not connect the power wiring to terminals for the transmission wiring. Doing so would destroy the entire system.
- When connecting wires to the terminal block on the PC-board, too much heat or tightening could damage the PC-board. Attach with care. See the table below for the tightening torque of the transmission wiring terminals.

Screw size	Tightening torque (N · m)
M3 (A5P)	0.53 - 0.63
M3.5 (A1P)	0.80 - 0.96

2.7.5 Power Wiring Connection Procedure

Be sure to connect the power supply wiring to the power supply terminal block and hold it in place using the included clamp as shown in the figure 26.

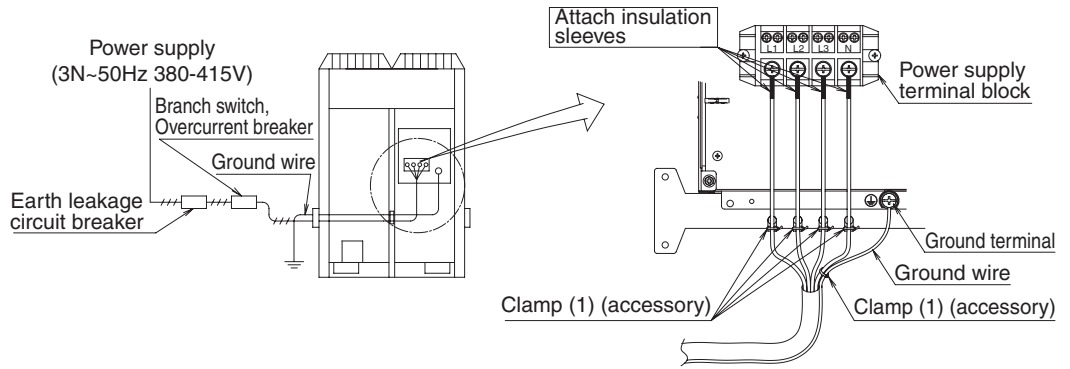

figure 26

- The L1, L2, L3 and N phases of the power wiring should be secured separately to the hook using the included clamp (1).
- The ground wiring should be bound to the power wiring using the included clamp (1) to prevent outside force from being applied to the terminal area.
- Wire so that the ground wiring does not come into contact with the compressor lead wiring. If they touch, this may have an adverse effect on other devices.



Caution:

- Be sure to use crimp-style terminal with insulating sleeves for connections. (See the figure below.)

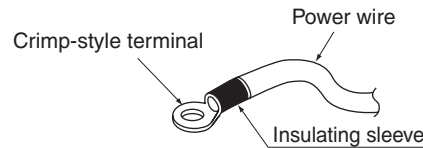

- For wiring, use the designated power wire and connect firmly, then secure to prevent outside pressure being exerted on the terminal board.
 - Use an appropriate screwdriver for tightening the terminal screws. A screwdriver with a small head will strip the head and make proper tightening impossible.
 - Over-tightening the terminal screws may break them.
- See the following table for the tightening torque of the terminal screws.

Screw size	Tightening torque (N·m)
M8 Power terminal, ground terminal	5.5 ~7.3

- When pulling the ground wire out, wire it so that it comes through the cut out section of the cup washer. (See the figure below.) An improper ground connection may prevent a good ground from being achieved.

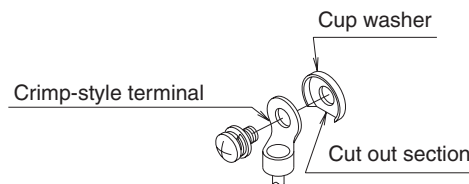

- When two wires are connected to a single terminal, connect them so that the rear sides of the crimp contacts face each other. Also, make sure the thinner wire is on top, securing the two wires simultaneously to the resin hook using the included clamp (1).

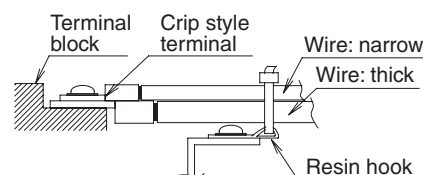

2.7.6 Procedure for Wiring Inside Units

- Referring to figure 27, secure and wire the power and transmission wiring using the included clamp (1), (2), and (3).

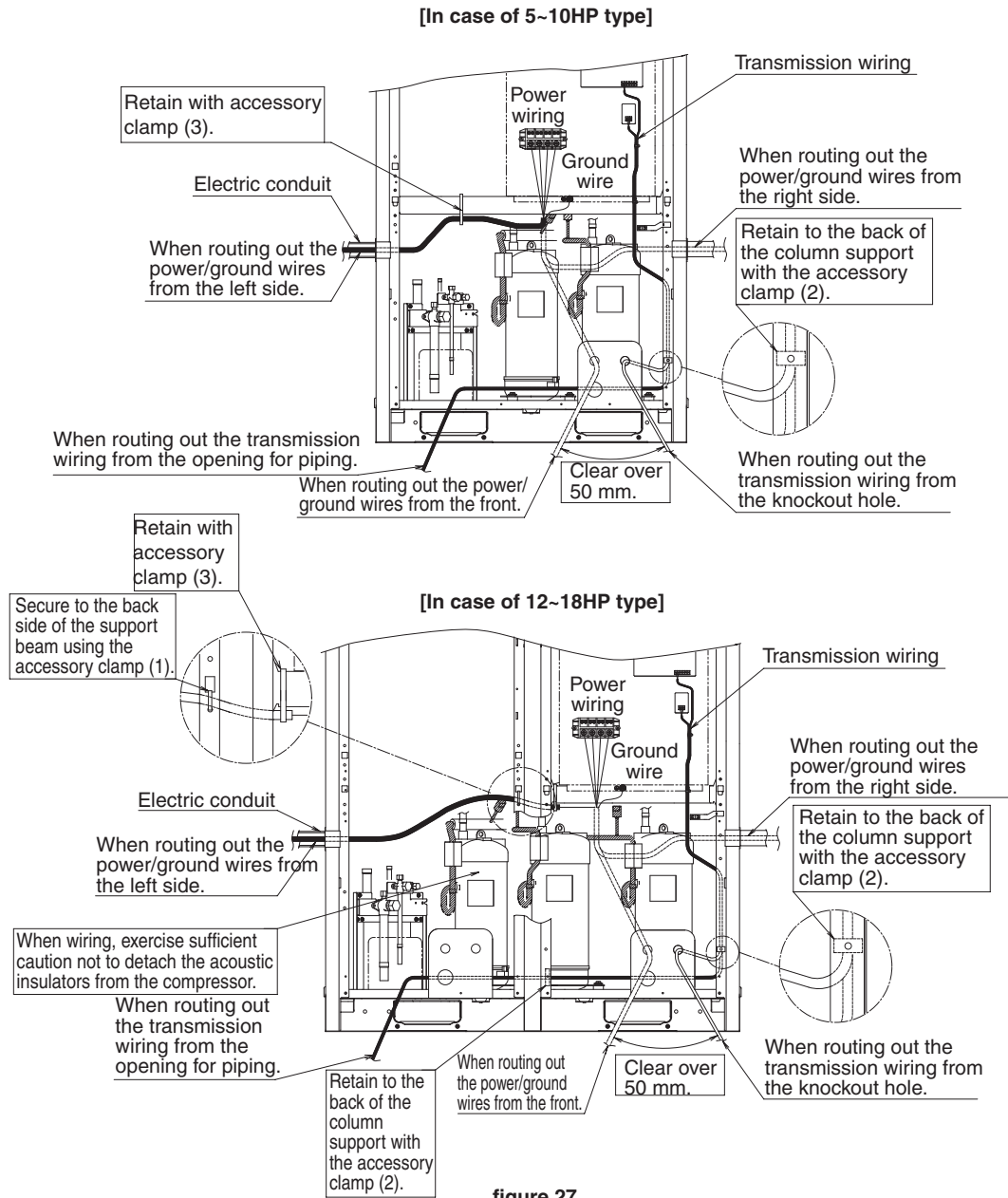

Caution:

- The transmission wiring must be at least 50 mm away from the power wiring.
- Make sure all wiring do not contact to the pipes (hatching parts in the figure 27).
- After wiring work is completed, check to make sure there are no loose connections among the electrical parts in the EL.COMPO.BOX.

2.8 Air Tight Test and Vacuum Drying

- i Note:**
- Always use nitrogen gas for the airtightness test.
 - Absolutely do not open the shutoff valve until the main power circuit insulation measurement has been completed. (measuring after the shutoff valve is opened will cause the insulation value to drop.)

2.8.1 Preparations

<Needed tools>

Gauge manifold Charge hose valve	<ul style="list-style-type: none"> To prevent entry of any impurities and insure sufficient pressure resistance, always use the special tools dedicated for R-410A. Use charge hose that have pushing stick for connecting to service port of shutoff valves or refrigerant charge port.
Vacuum pump	<ul style="list-style-type: none"> The vacuum pump for vacuum drying should be able to lower the pressure to -100.7kPa (5 Torr -755mm Hg). Take care the pump oil never flow backward into the refrigerant pipe during the pump stops.

<The system for air tight test and vacuum drying>

- Referring to figure 28, connect an nitrogen tank, refrigerant tank, and a vacuum pump to the outdoor unit.
The refrigerant tank and the charge hose connection to refrigerant charge port or the valve A, C in figure 28 are needed in "2-11 Additional Refrigerant Charge and Check Operation".
- The shutoff valve and valve A~C in figure 28 should be open or closed as shown in the table below.

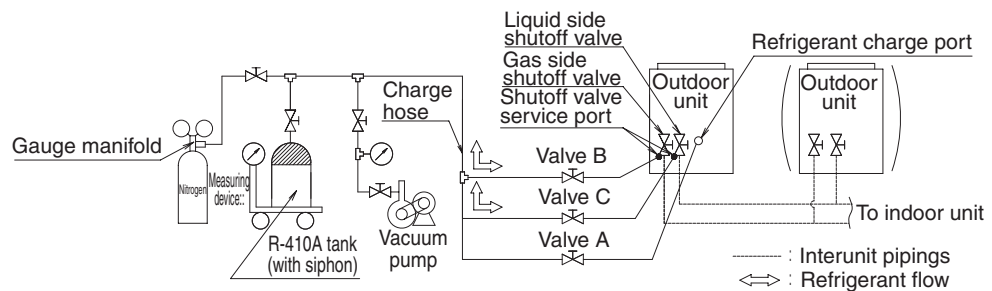
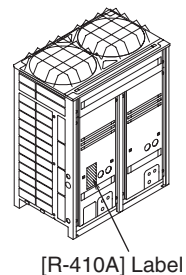

figure 28

State of valve A, B and C and shutoff valves	Valve			shutoff valve	
	A	B	C	Liquid side	Gas side
Air tight test, Vacuum drying (Close valve A and shutoff valves certainly. Otherwise the refrigerant in the unit are released.)	Close	Open	Open	Close	Close

- i Note:**
- The airtightness test and vacuum drying should be done using the liquid side and gas side shutoff valve service ports. See the [R-410A] Label attached to the front plate of the outdoor unit for details on the location of the service port (see figure at right).
 - See [Shutoff valve operation procedure] in "2-11-1 Before working" for details on handling the shutoff valve.
 - The refrigerant charge port is connected to unit pipe. When shipped, the unit contains the refrigerant, so use caution when attaching the charge hose.



2.8.2 Air tight test and vacuum drying method

After finished piping work, carry out air tight test and vacuum drying.

<Air tight test>

Pressurize the liquid and gas pipes to 4.0MPa (40bar) (do not pressurize more than 4.0MPa (40bar)). If the pressure does not drop within 24 hours, the system passes the test.

If there is a pressure drop, check for leaks, make repairs and perform the airtight test again.

<Vacuum drying>

Evacuate the system from the liquid and gas pipes by using a vacuum pump for more than 2 hours and bring the system to

–100.7kPa or less. After keeping the system under that condition for more than 1 hour, check if the vacuum gauge rises or not. If it rises, the system may either contain moisture inside or have leaks.



Note:

If moisture might enter the piping, follow below.

(I.e., if doing work during the rainy season, if the actual work takes long enough that condensation may form on the inside of the pipes, if rain might enter the pipes during work, etc.)

(1) After performing the vacuum drying for two hours, pressurize to 0.05 MPa (i.e., vacuum breakdown) with nitrogen gas, then depressurize down to –100.7 kPa for an hour using the vacuum pump (vacuum drying).

(2) If the pressure does not reach –100.7 kPa even after depressurizing for at least two hours, repeat the vacuum breakdown - vacuum drying process.

After vacuum drying, maintain the vacuum for an hour and make sure the pressure does not rise by monitoring with a vacuum gauge.

2.9 Pipe Insulation

- Insulation of pipes should be done after performing “**2-8 Air Tight Test and Vacuum Drying**”.
- Always insulate the liquid side piping and gas side piping in the interunit piping and refrigerant branching kit. Failing to insulate the pipes could cause leaking or burns. (The gas side piping can reach temperatures of 120°C. Be sure the insulation used can withstand such temperatures.)
- Reinforce the insulation on the refrigerant piping according to the installation environment. Condensation might form on the surface of the insulation.
 - ◆ Ambient temperature: 30°C, humidity: 75% to 80% RH: min. thickness: 15 mm.
 - ◆ If the ambient temperature exceeds 30°C and the humidity 80% RH, then the min. thickness is 20 mm.
- If there is a possibility that condensation on the shutoff valve might drip down into the indoor unit through gaps in the insulation and piping because the outdoor unit is located higher than the indoor unit, etc., this must be prevented by caulking the connections, etc. (**Refer to figure 29**)
- The piping lead-out hole lid should be attached after opening a knock hole. (**Refer to figure 30**)
- If small animals and the like might enter the unit through the piping lead-out hole, close the hole with blocking material (procured on site) after completion of “**2-11 Additional Refrigerant Charge and Check Operation**”. (**Refer to figure 30**)

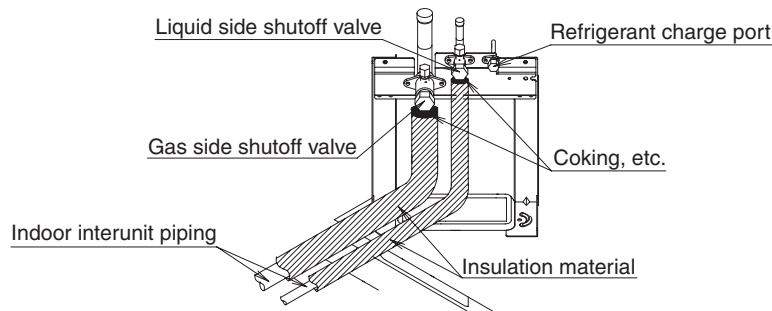

figure 29

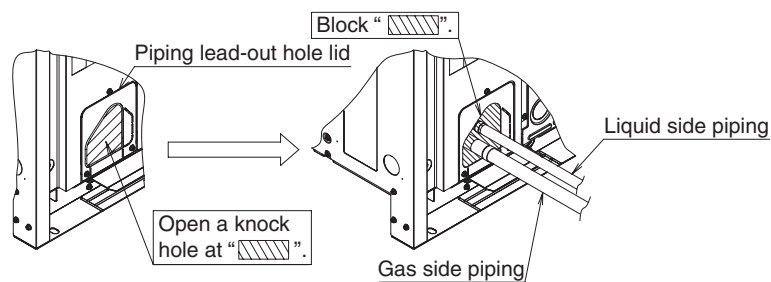

figure 30



- Note:**
- After knocking out the holes, we recommend you remove burrs in the knock holes (see figure 30) and paint the edges and areas around the edges using the repair paint.

2.10 Checking of Device and Installation Conditions

Be sure to check the followings.

For those doing electrical work

1. Make sure there is no faulty transmission wiring or loosen a nut.
See “**2-7-4 Transmission Wiring Connection Procedure**”.
2. Make sure there is no faulty power wiring or loosen a nut.
See “**2-7-5 Power Wiring Connection Procedure**”.
3. Has the insulation of the main power circuit deteriorated?
Measure the insulation and check the insulation is above regular value in accordance with relevant local and national regulations.

For those doing pipe work

1. Make sure piping size is correct.
See “**2-6-1 Selection of piping material and Refrigerant branching kit**”.
2. Make sure insulation work is done.
See “**2-9 Pipe Insulation**”.
3. Make sure there is no faulty refrigerant piping.
See “**2-6 Refrigerant Piping**”.



2.11 Additional Refrigerant Charge and Check Operation

The outdoor unit is charged with refrigerant when shipped from the factory, but depending on the size and length of the piping when installed, it may require additional charging. For charging the additional refrigerant, follow the procedure in this chapter. And then carry out the check operation.

2.11.1 Before working

[About the refrigerant tank]

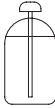
Check whether the tank has a siphon pipe before charging and place the tank so that the refrigerant is charged in liquid form. (See the figure below.)

With siphon pipe	
	Stand the tank upright and charge. (The siphon pipe goes all the way inside, so the tank does not need be put upside-down charge in liquid form.)
Other tanks	
	Stand the tank upside-down and charge.



Caution:

- Always use the proper refrigerant (R-410A). If charged with the refrigerant containing an improper material, it may cause an explosion or accident.
- R-410A is a mixed refrigerant, so charging it as a gas will cause the refrigerant composition to change, which may prevent normal operation.

[Shutoff valve operation procedure]

When operating the shutoff valve, follow the procedure instructed below.



Note:

- Do not open the shutoff valve until “2-10 Checking of Device and Installation Conditions” are completed. If the shutoff valve is left open without turning on the power, it may cause refrigerant to buildup in the compressor, leading insulation degradation.
- Be sure to use the correct tools.
The shutoff valve is not a back-seat type. If forced it to open, it might break the valve body.
- When using a service port, use the charge hose.
- After tightening the cap, make sure no refrigerant gas is leaking.

[Tightening torque]

The sizes of the shutoff valves on each model and the tightening torque for each size are listed in the table below.

<Size of Shutoff Valve>

	5HP type	8HP type	10HP type	12HP type	14HP type	16HP type	18HP type
Liquid side shutoff valve	ϕ 9.5 The 12HP type corresponds to the 12.7-diameter onsite piping using the included piping.				ϕ 12.7 The 18HP type corresponds to the 15.9-diameter onsite piping using the accessory pipe.		
Gas side shutoff valve	ϕ 15.9	ϕ 19.1	ϕ 25.4 The 10HP type corresponds to the 22.2-diameter onsite piping using the accessory pipe. The 12 ~ 18HP type corresponds to the 28.6-diameter onsite piping using the accessory pipe.				

<Tightening torque>

Shutoff valve size	Tightening torque N·m (Turn clockwise to close)			
	Shaft (valve body)		Cap (valve lid)	Service port
φ 9.5	5.4 - 6.6	Hexagonal wrench 4 mm	13.5 - 16.5	11.5 - 13.9
φ 12.7	8.1 - 9.9		18.0 - 22.0	
φ 15.9	13.5 - 16.5	Hexagonal wrench 6 mm	22.5 - 27.5	
φ 19.1	27.0 - 33.0	Hexagonal wrench 8 mm		
φ 25.4				

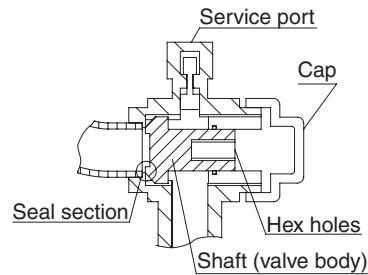

figure 34

[To open]

1. Remove the cap and turn the shaft counterclockwise with the hexagon wrench (JISB4648).
2. Turn it until the shaft stops.
3. Make sure to tighten the cap securely.
(For the tightening torque, refer to the item <Tightening Torque>.)

[To close]

1. Remove the cap and turn the shaft clockwise with the hexagon wrench (JISB4648).
2. Securely tighten the valve until the shaft contacts the main body seal.
3. Make sure to tighten the cap securely.
(For the tightening torque, refer to the item <Tightening Torque>.)

[How to Check How Many Units are Connected]

It is possible to find out how many indoor or outdoor unit in the system are turned on by operating the push button on the PC-board (A1P) of outdoor unit (In case of multi system master unit).

Follow the procedure below to check how many indoor or outdoor units are turned on.

(LED display: ● ...OFF ☀ ...ON ⚡ ...Blinking * ...Uncertain)		LED display						
		H1P	H2P	H3P	H4P	H5P	H6P	H7P
(1)	Press the MODE button (BS1) once, and set the MONITOR MODE (H1P: Blinking).	⚡	●	●	●	●	●	●
(2)	Press the SET button (BS2) the number of times until the LED display matches that at right.	For checking the number of outdoor units: eight times	⚡	●	●	☀	●	●
		For checking the number of indoor units: five times	⚡	●	●	●	☀	●
(3)	Press the RETURN button (BS3) and read the number of units from the display of H2P through H7P. [Reading Method] The display of H2P through H7P should be read as a binary number, with ⚡ standing for "1" and ● standing for "0".	⚡	*	*	*	*	*	*
<p>Ex: For the LED display at right, this would be "0 1 0 1 1 0", which would mean 22 units are connected.</p> <p style="text-align: center;">$32 \times 0 + 16 \times 1 + 8 \times 0 + 4 \times 1 + 2 \times 1 + 1 \times 0 = 22$ units</p> <p>Note: "000000" indicates 64 units.</p>		⚡	●	⚡	●	⚡	⚡	●
(4)	Press the MODE button (BS1) once. This returns to Setting Mode 1 (default).	●	●	☀	●	●	●	●



Note: Press the "MODE button" (BS1) if you get confused while operating. This returns to **Setting Mode 1** (default).

2.11.2 Procedure of Adding Refrigerant Charging and Check Operation



Warning



Electric Shock Warning:

- Make sure to close the EL. COMPO. BOX lid before turning on the power when performing the refrigerant charging operation.
- Perform the setting on the PC-board (A1P) of the outdoor unit and check the LED display after the power is on via the inspection door which is in the EL. COMPO. BOX lid.
- Use an insulated rod to operate the push buttons via the EL. COMPO. BOX's inspection door.

There is a risk of electric shock if you touch any live parts, since this operation must be performed with the power on.



Caution:

- Make sure to use the protect tool (protective grooves and goggles) when charging the refrigerant.
- Due to a danger of liquid hammer, the refrigerant must not be charged over the allowable maximum amount when charging the refrigerant.
- Do not perform the refrigerant charging operation under working for the indoor unit.
- When opening the front panel, make sure to take caution to the fan rotation during the working.

After the outdoor unit stops operating, the fan may keep rotation for a while.



- Note:**
- If operation is performed within 12 minutes after the indoor and outdoor units are turned on, H2P will be lit on and the compressor will not operate.
 - In order to ensure uniform refrigerant distribution, it may take up to around 10 minutes for the compressor to start up after the unit starting operating. This is not a malfunction.

<About refrigerant charging>

- The refrigerant charge port is connected to the piping inside the unit.
When the unit is shipped from the factory, the unit's internal piping is already charged with refrigerant, so be careful when connecting the charge hose.
- After adding the refrigerant, make sure to close the lid of the refrigerant charging port.
The tightening torque for the lid is 11.5 to 13.9 Nm.
- See [Shutoff valve operation procedure] in chapter 2-11-1 for details on how to handle shutoff valves.
- When done or when pausing the refrigerant charging operation, close the valve of the refrigerant tank immediately. If the tank is left with the valve open, the amount of refrigerant which is properly charged may be off the point. More refrigerant may be charged by any remaining pressure after the machine is stopped.

<About check operation>

- Make sure to perform the check operation after installation. Otherwise, the malfunction code "U3" will be displayed and normal operation cannot be performed.
And the failure of "Check of miswiring" may also cause abnormal operation. Performance may drop due to the failure of "Judgment of piping length".
- Check operation must be performed for each refrigerant piping system.
Checking is impossible if plural systems are being done at once.
- The individual problems of indoor units can not be checked.
About these problems check by test run after the check operation is completed. (See chapter 2-13)
- The check operation cannot be performed in recovery or other service modes.

1. Make sure the following works are complete in accordance with the installation manual.
 - Piping work
 - Wiring work
 - Air tight test
 - Vacuum drying
 - Installation work for indoor unit
2. Calculate the "additional charging amount" using "How to calculate the additional refrigerant to be charged" in "2-6-5 Example of connection".
3. Open the valve C (See the figure 31. The valve A, B and the liquid and gas side shutout valve must be left closed), and charge the refrigerant of the "additional charging amount" from the liquid side shutout valve service port.
If the "additional charging amount" was charged fully, close the valve C and go to step 5.
If the "additional charging amount" was not charged fully, go to step 4.

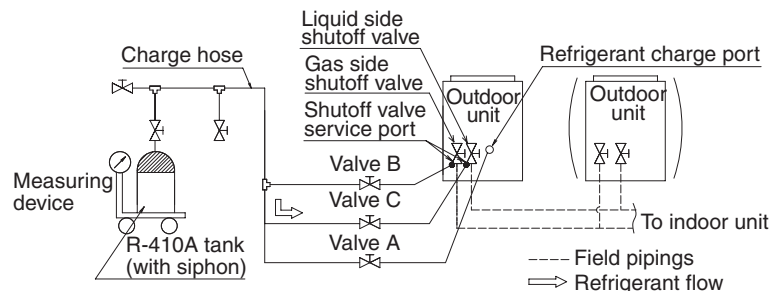

figure 31

- Perform the refrigerant charging operation following [Refrigerant charging operation procedure] as shown below, and charge the remaining refrigerant of the "additional charging amount". For performing the refrigerant charging operation the push button on the PC-board (A1P) of outdoor unit (In case of multi system master unit) are use. (See the figure 32) In addition, the refrigerant are charged from the refrigerant charge port via the valve A. (See the figure 33)

For operating the push button and opening and closing the valve, follow the work procedure.



Note: The refrigerant will be charged about 22kg in one hour at outdoor temp. 30°C DB (6kg at 0°C DB).
If you need to speedup in case of multi system, connect the refrigerant tanks to each outdoor unit as shown in the figure 33.

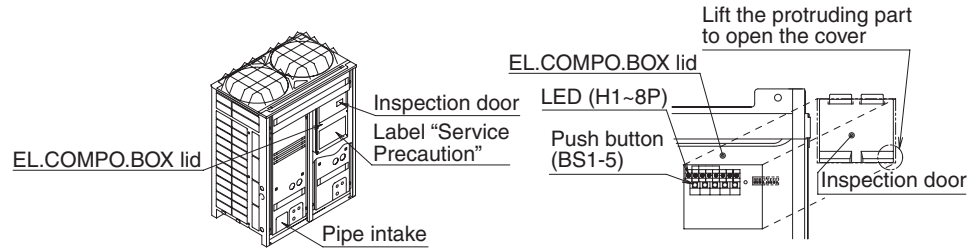

figure 32

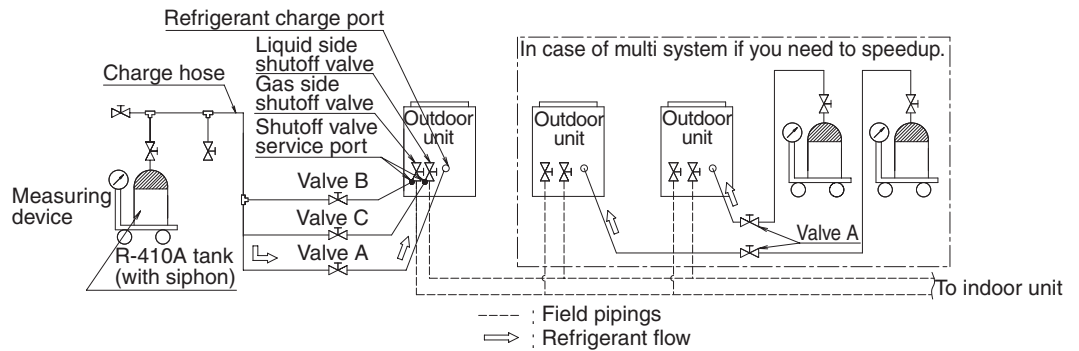

figure 33

[Refrigerant Charging Operation Procedure]

- Open the liquid and gas side shutoff valves (The valve A~C must be closed. The valve A~C means the valves in the figure 33.)

[Display of normal system]

LED display (Default status of shipped)	SERV. MONITOR	MODE	TEST/HWL	C/H SELECTOR			L.N.O.P	DEMAND	MULTI
				IND	MASTER	SLAVE			
				H3P	H4P	H5P			
Single system	●	●	●	☼	●	●	●	●	●
Multi system (*)	Master unit	●	●	●	☼	●	●	●	☼
	Sub unit 1	●	●	●	●	●	●	●	●
	Sub unit 2	●	●	●	●	●	●	●	●

LED display: ●...OFF, ☼...ON, ●...Blinking

(*)How to distinguish the master unit, sub unit 1, and sub unit 2 in the multi system.

Method 1: By the H8P (MULTI) LED display

☀ (ON): Master unit	⏸ (Blinking): Sub unit 1	● (OFF): Sub unit 2
---------------------	--------------------------	---------------------

Method 2: By the transmission wiring to indoor unit

Transmission wiring is connected: Master unit
Transmission wiring is not connected : Sub unit 1 or Sub unit 2

- (2) If necessary, set the field setting by using the dip switch on the outdoor unit PC-board (A1P).
(For how to set, see "2-12-1 Onsite Settings With the Power Off")
 - (3) • Close the EL. COMPO. BOX lid and all front panel except on the side of the EL. COMPO. BOX (*1) and turn the power to the outdoor unit and all connected indoor units. (*2)
 - After H2P stop blinking (about 12 minutes after turning on the power), check LED displays as shown in the table [Display of normal system] and the system is normal state.
If H2P is blinking, check the malfunction code in the remote control, and correct the malfunction in accordance with [remote control display malfunction code] in step 5.
 - (*1) Lead the refrigerant charge hose etc., from the pipe intake. All front panels must be closed at the procedure (9).
 - (*2) • If you perform the refrigerant charging operation within the refrigerant system that have the power off unit, the operation cannot finish properly.
For confirming the number of the outdoor and indoor units with the power on, see [How to check how many units are connected] in chapter 2-11-1. In case of a multi system, turn on the power to all outdoor units in the refrigerant system.
 - To energize the crankcase heater, make sure to turn on for 6 hours before starting operation.
 - (4) Start the additional refrigerant charge operation.
(About the system settings for additional refrigerant charge operation, refer to the [Service Precaution] label attached on the EL. COMPO. BOX lid in the outdoor unit.)
Open valve A immediately after starting the compressor.
 - (5) Close the valve A if the "additional charging amount" of refrigerant was charged, and push the RETURN button (BS3) once.
 - (6) Record the charging amount on the accessory "REQUEST FOR THE INDICATION" label and attach it to the back side of the front panel.
5. After completing the additional refrigerant charging perform the check operation following below.

**Note:**

- For check operation, the following work will be performed.
 - ◆ Check of shutoff valve opening
 - ◆ Check of miswiring
 - ◆ Judgment of piping length
 - ◆ Check of refrigerant overcharge
- It takes about 40 minutes to complete the check operation.

[Check Operation Procedure]

- (1) Make the onsite setting as needed using the dip switches on the outdoor unit PC-board (A1P) with the power off (See "2-12-1 Onsite Settings With the Power Off")
- (2) Close the EL. COMPO. BOX lid and all front panels except as the side of the EL. COMPO. BOX and turn on the power to the outdoor unit and all connected indoor units. (Be sure to turn the power on at least 6 hours before operation in order to have power running to the crank case heater.)

- (3) Check the LED display on the outdoor unit PC-board (A1P) is as shown in the table below and transmission is normal.

LED display (Default status of shipped)	SERV. MONITOR	MODE	TEST/HWL	C/H SELECTOR			L.N.O.P	DEMA-ND	MULTI
				IND	MASTER	SLAVE			
	HAP	H1P	H2P	H3P	H4P	H5P	H6P	H7P	H8P
Single system	◐	●	●	☀	●	●	●	●	●
Multi system (*)	Master unit	◐	●	●	☀	●	●	●	☀
	Sub unit 1	◐	●	●	●	●	●	●	◐
	Sub unit 2	◐	●	●	●	●	●	●	●

LED display: ●...OFF, ☀...ON, ◐...Blinking

(*)How to distinguish the master unit, sub unit 1, and sub unit 2 in the multi system.

Method 1: By the H8P (MULTI) LED display

☀ (ON): Master unit	◐ (Blinking): Sub unit 1	● (OFF): Sub unit 2
---------------------	--------------------------	---------------------

Method 2: By the transmission wiring to indoor unit

Transmission wiring is connected: Master unit
Transmission wiring is not connected : Sub unit 1 or Sub unit 2

- (4) Make the onsite settings as needed using the push button (BS1-BS5) on the outdoor unit PC-board (A1P) with the power on. (See “2-12-2 Onsite Settings With the Power On”)
- (5) Perform the check operation following the Check Operation Method of the [Service Precautions] label on the EL. COMPO. BOX lid. The system operation for about 40 minutes and automatically stops the check operation.
- If the malfunction code is not displayed in the remote control after the system stop, check operation is completed. Normal operation will be possible after 5 minutes. If the malfunction code is displayed in the remote control, correct the malfunction following [remote control displays malfunction code] and perform the check operation again.

[remote control displays malfunction code]

Malfunction code	Installation error	Remedial action
E3, E4 F3, F6 UF	The shutoff valve of the outdoor unit is left closed.	Open the shutoff valve.
U1	The phases of the power to the outdoor unit is reversed.	Exchange two of the three phases (L1, L2, L3) to make a proper connection.
U1 U4 LC	No power is supplied to an outdoor or indoor unit (including phase interruption).	Make sure the power source wire is properly connected to the outdoor unit and revise if necessary.
UF	There is conflict on the connection of transmission wiring in the system.	Check if the refrigerant piping line and the transmission wiring are consistent with each other.
E3 F6 UF	Refrigerant overcharge.	Recalculate the additional amount refrigerant from the piping length and correct the refrigerant charge level by recovering any excessive refrigerant with a refrigerant recovery machine.
E4 F3	Insufficient refrigerant.	<ul style="list-style-type: none"> ■ Check if the additional refrigerant charge has been finished correctly. ■ Recalculate the additional amount refrigerant from the piping length and add the adequate amount.
U7, U4 UF, UH	If the outdoor unit terminal is connected when there is one outdoor unit installed.	Remove the line from the outdoor multi terminals (Q1 and Q2).

If any malfunction codes other than the above are displayed, check the service manual for how to respond.

2.12 Onsite Settings

- i Note:** In the case of a multi system, all onsite settings should be made on the master unit. Settings made on sub units are invalid.
The outdoor unit to which the indoor unit transmission wire are connected is the master unit, and all other units are sub units.

2.12.1 Onsite Settings with the Power Off

If the COOL/HEAT selector was connected to the outdoor unit in “2-7. Field Wiring”, set the dip switch (DS1) on the outdoor unit PC-board (A1P) to “ON” (it is set to “OFF” when shipped from the factory).

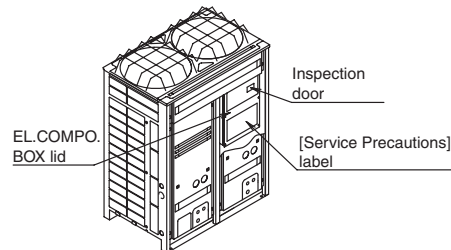

For the position of the dip switch (DS1), see the “Service Precautions” label (see at right) which is attached to the EL. COMPO. BOX lid.



Warning



Electric Shock Warning:

Never perform with the power on.

There is a serious risk of electric shock if any live part is touched.

2.12.2 Onsite Settings with the Power On

Use the push button switches (BS1 through BS5) on the outdoor unit PC-board (A1P) to make the necessary onsite settings.

See the “Service Precautions” label on the EL. CONPO. BOX lid for details on the positions and operating method of the push button switches and on the onsite setting.

Make sure to record the setting on the accessory “REQUEST FOR THE INDICATION” label.



Warning



Electric Shock Warning:

Use an insulated rod to operate the push buttons via the inspection door of EL. COMPO. BOX lid.

There is a risk of electric shock if you touch any live parts, since this operation must be performed with the power on.

2.13 Test Run

2.13.1 Before Test Run

- Make sure the following works are completed in accordance with the installation manual.
 - ◆ Piping work
 - ◆ Wiring work
 - ◆ Air tight test
 - ◆ Vacuum drying
 - ◆ Additional refrigerant charge
- Check that all work for the indoor unit are finished and there are no danger to operate.

2.13.2 Test Run

After check operation is completed, operate the unit normally and check the following.

1. Make sure the indoor and outdoor units are operating normally.
2. Operate each indoor unit one by one and make sure the corresponding outdoor unit is also operating.
3. Check to see if cold (or hot) air is coming out from the indoor unit.
4. Push the fan direction and strength buttons on the remote control to see if they operate properly.



Note:

- Heating is not possible if the outdoor temperature is 24°C or higher. Refer to the Operation manual.
- If a knocking sound can be heard in the liquid compression of the compressor, stop the unit immediately and then energize the crank case heater for a sufficient length of time before restarting the operation.
- Once stopping, the compressor will not restart in about 5 minutes even if the On/Off button of the remote control is pushed.
- When the system operation is stopped by the remote control, the outdoor units may continue operating for further 5 minutes at maximum.
- The outdoor unit fan may rotate at low speeds if the Night-time low noise setting or the External low noise level setting is made, but this is not a malfunction.

2.13.3 Checks after Test Run

Perform the following checks after the test run is complete.

- Record the contents of field setting.
 - Record them on the accessory “REQUEST FOR THE INDICATION” label. And attach the label on the back side of the front panel.
- Record the installation date.
 - Record the installation date on the accessory “REQUEST FOR THE INDICATION” label in accordance with the IEC60335-2-40. And attach the label on the back side of the front panel.



Note:

After the test run, when handing the unit over to the customer, make sure the EL.COMPO.BOX lid, the inspection door, and the unit casing are all attached.

2.14 Caution for Refrigerant Leaks

(Points to note in connection with refrigerant leaks)

Introduction

The installer and system specialist shall secure safety against leakage according to local regulations or standards. The following standards may be applicable if local regulations are not available.

The VRV System, like other air conditioning systems, uses R-410A as refrigerant. R-410A itself is an entirely safe non-toxic, non-combustible refrigerant. Nevertheless care must be taken to ensure that air conditioning facilities are installed in a room which is sufficiently large. This assures that the maximum concentration level of refrigerant gas is not exceeded, in the unlikely event of major leak in the system and this in accordance to the local applicable regulations and standards.

Maximum concentration level

The maximum charge of refrigerant and the calculation of the maximum concentration of refrigerant is directly related to the humanly occupied space in to which it could leak.

The unit of measurement of the concentration is kg/m^3 (the weight in kg of the refrigerant gas in 1m^3 volume of the occupied space).

Compliance to the local applicable regulations and standards for the maximum allowable concentration level is required.

In Australia the maximum allowed concentration level of refrigerant to a humanly space is limited to $0.35\text{kg}/\text{m}^3$ for R-407C and $0.44\text{kg}/\text{m}^3$ for R-410A.

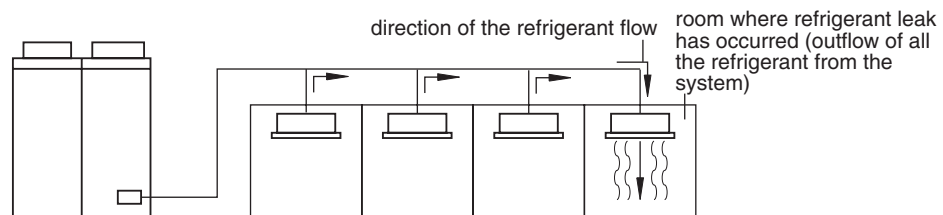

Pay a special attention to the place, such as a basement, etc. where refrigerant can stay, since refrigerant is heavier than air.

Procedure for checking maximum concentration

Check the maximum concentration level in accordance with steps 1 to 4 below and take whatever action is necessary to comply.

1. Calculate the amount of refrigerant (kg) charged to each system separately.

amount of refrigerant in a single unit system (amount of refrigerant with which the system is charged before leaving the factory)	+	additional charging amount (amount of refrigerant added locally in accordance with the length or diameter of the refrigerant piping)	=	total amount of refrigerant (kg) in the system
---	---	--	---	--



Note:

- Where a single refrigerant facility is divided into 2 entirely independent refrigerant systems then use the amount of refrigerant with which each separate system is charged.

2. Calculate the smallest room volume (m^3)
In case like the following, calculate the volume of (A), (B) as a single room or as the smallest room.

A. Where there are no smaller room divisions

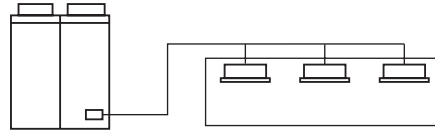

B. Where there is a room division but there is an opening between the rooms sufficiently large to permit a free flow of air back and forth.

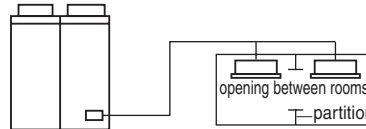

(Where there is an opening without a door or where there are openings above and below the door which are each equivalent in size to 0.15% or more of the floor area.)

3. Calculating the refrigerant density using the results of the calculations in steps 1 and 2 above.

$$\frac{\text{total volume of refrigerant in the refrigerant system}}{\text{size (m}^3\text{) of smallest room in which there is an indoor unit installed}} \leq \text{maximum concentration level (kg/m}^3\text{)}$$

If the result of the above calculation exceeds the maximum concentration level then make similar calculations for the second then third smallest room and so until the result falls short of the maximum concentration.

4. Dealing with the situations where the result exceeds the maximum concentration level.
Where the installation of a facility results in a concentration in excess of the maximum concentration level then it will be necessary to revise the system. Please consult your Daikin supplier.

Part 3

Operation Manual

1. Heat Pump / Cooling Only 50Hz (RX(Y)Q5~54P)	310
1-1 Safety Cautions	311
1-2 Specifications	312
1-3 What to do before Operation	312
1-4 Remote Controller and COOL/HEAT Selector: Name and Function of Each Switch and Display (Refer to figure 2 and 3)	313
1-5 Operation Range	313
1-6 Operation Procedure	314
1-7 Optimum Operation	317
1-8 Seasonal Maintenance	317
1-9 Following Symptoms are not Air Conditioner Troubles	317
1-10 Trouble Shooting	319
2. Heat Pump 60Hz (RXYQ5~54P).....	321
2-1 Safety Cautions	322
2-2 Specifications	323
2-3 What to do before Operation	323
2-4 Remote Controller and COOL/HEAT Selector: Name and Function of each Switch and Display (Refer to figure 2 and 3)	323
2-5 Operation Range	324
2-6 Operation Procedure	324
2-7 Optimum Operation	328
2-8 Seasonal Maintenance	328
2-9 Following Symptoms are not Air Conditioner Troubles	328
2-10 Trouble Shooting	330

1. Heat Pump / Cooling Only 50Hz (RX(Y)Q5~54P)

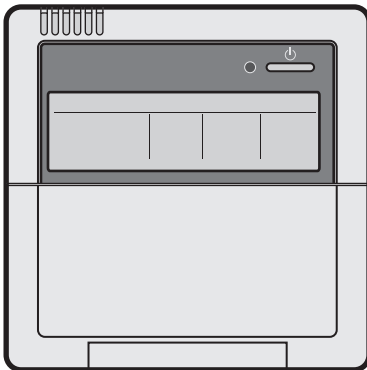
DAIKIN**OPERATION MANUAL****VRV III** System air conditioner

RXYQ5PY1	RXQ5PY1
RXYQ8PY1	RXQ8PY1
RXYQ10PY1	RXQ10PY1
RXYQ12PY1	RXQ12PY1
RXYQ14PY1	RXQ14PY1
RXYQ16PY1	RXQ16PY1
RXYQ18PY1	RXQ18PY1
RXYQ20PY1	RXQ20PY1
RXYQ22PY1	RXQ22PY1
RXYQ24PY1	RXQ24PY1
RXYQ26PY1	RXQ26PY1
RXYQ28PY1	RXQ28PY1
RXYQ30PY1	RXQ30PY1
RXYQ32PY1	RXQ32PY1
RXYQ34PY1	RXQ34PY1
RXYQ36PY1	RXQ36PY1
RXYQ38PY1	RXQ38PY1
RXYQ40PY1	RXQ40PY1
RXYQ42PY1	RXQ42PY1
RXYQ44PY1	RXQ44PY1
RXYQ46PY1	RXQ46PY1
RXYQ48PY1	RXQ48PY1
RXYQ50PY1	RXQ50PY1
RXYQ52PY1	RXQ52PY1
RXYQ54PY1	RXQ54PY1

1-1 Safety Cautions

Read the following cautions carefully and use your equipment properly.

There are two kinds of safety cautions and tips listed here as follows:

 **Warning** Improper handling can lead to such serious consequences as death or severe injury.

 **Caution**..... Improper handling can lead to injury or damage. It could also have serious consequences under certain conditions.

Note

Keep this operation manual handy so that you can refer to them if needed.

Also, if this equipment is transferred to a new user, make sure to hand over this operation manual to the new user.

Warning

It is not good for your health to expose your body to the air flow for a long time.

In order to avoid electric shock, fire or injury, or if you detect any abnormality such as smell of fire, turn off power and call your dealer for instructions.

Ask your dealer for installation of the air conditioner.

Incomplete installation performed by yourself may result in a water leakage, electric shock, and fire.

Ask your dealer for improvement, repair, and maintenance.

Incomplete improvement, repair, and maintenance may result in a water leakage, electric shock, and fire.

Do not put a finger, a rod or other objects into the air inlet or outlet. As the fan is rotating at high speed, it will cause injury. Never touch the air outlet or the horizontal blades while the swing flap is in operation.

Fingers may become caught or the unit may break down.

The refrigerant in the air conditioner is safe and normally does not leak. If the refrigerant leaks inside the room, the contact with a fire of a burner, a heater or a cooker may result in a harmful gas.

Turn off any combustible heating devices, ventilate the room, and contact the dealer where you purchased the unit.

Do not use the air conditioner until when a service person confirms to finish repairing the portion where the refrigerant leaks.

For refrigerant leakage, consult your dealer.

When the air conditioner is to be installed in a small room, it is necessary to take proper measures so that the amount of any leaked refrigerant does not exceed the limiting concentration even when it leaks. If the refrigerant leaks exceeding the level of limiting concentration, an oxygen deficiency accident may happen.

Improper installation or attachment of equipment or accessories could result in electric shock, short-circuit, leaks, fire or other damage to the equipment. Be sure only to use accessories made by Daikin which are specifically designed for use with the equipment and have them installed by a professional.

Ask your dealer to move and reinstall the air conditioner.

Incomplete installation may result in a water leakage, electric shock, and fire.

In order to avoid electric shock, fire, injury or damaging the unit, do not use improper ampere fuses or do not use copper nor steel wires instead.

Be sure to establish an earth.

Do not earth the unit to a utility pipe, arrester, or telephone earth.

Incomplete earth may cause electrical shock, or fire.

A high surge current from lightning or other sources may cause damage to the air conditioner.

Be sure to install an earth leakage breaker.

Failure to install an earth leakage breaker may result in electric shocks, or fire.

Caution

Do not use the air conditioner for other purposes.

In order to avoid any quality deterioration, do not use the unit for cooling precision instruments, food, plants, animals or works of art.

In order to avoid injury, do not remove the fan guard of outdoor unit.

To avoid oxygen deficiency, ventilate the room sufficiently if equipment with burner is used together with the air conditioner.

After a long use, check the unit stand and fitting for damage. If they are left in a damaged condition, the unit may fall and result in injury.

Neither place a flammable spray bottle near the air conditioner nor perform spraying.

Doing so may result in a fire.

Before cleaning, be sure to stop the operation, turn the breaker off.

Otherwise, an electric shock and injury may result.

Do not operate the air conditioner with a wet hand.

An electric shock may result.

Do not place items which might be damaged by moisture under the indoor unit which may be damaged by water.

Condensation may form if the humidity is above 80%, if the drain outlet gets blocked or the filter is polluted.

Do not place appliances which produce open fire in places exposed to the air flow from the unit or under the indoor unit. It may cause incomplete combustion or deformation of the unit due to the heat.

Do not mount on the outdoor unit or avoid placing any object on it.

Falling or tumbling may result in injury.

Never expose little children, plants or animals directly to the air flow.

Adverse influence to little children, animals and plants may result.

Do not wash the air conditioner with water.

Electric shock or fire may result.

Do not install the air conditioner at any place where flammable gas may leak out.

If the gas leaks out and stays around the air conditioner, a fire may break out.

Arrange the drain hose to ensure smooth drainage. Incomplete drainage may cause wetting of the building, furniture etc.

Do not let children play on and around the outdoor unit.

If they touch the unit carelessly, it may result in injury.

Do not place a flower vase or anything containing water on the indoor unit.

Water may enter the unit, causing an electric shock or fire.

Do not place the controller exposed to direct sunlight.

The LCD display may get discolored, failing to display the data.

Do not wipe the controller operation panel with benzine, thinner, chemical dustcloth, etc.

The panel may get discolored or the coating peeled off. If it is heavily dirty, soak a cloth in water-diluted neutral detergent, squeeze it well and wipe the panel clean. And wipe it with another dry cloth.

Never touch the internal parts of the controller.

Do not remove the front panel. Some parts inside are dangerous to touch, and a machine trouble may happen. For checking and adjusting the internal parts, contact your dealer.

Avoid placing the controller in a spot splashed with water.

Water coming inside the machine may cause an electric leak or may damage the internal electronic parts.

Never press the button of the remote control with a hard, pointed object.

The remote control may be damaged.

Never pull or twist the electric wire of a remote control.

It may cause the unit to malfunction.

Do not operate the air conditioner when using a room fumigation - type insecticide.

Failure to observe could cause the chemicals to become deposited in the unit, which could endanger the health of those who are hypersensitive to chemicals.

The appliance is not intended for use by young children or infirm persons without supervision.

Young children should be supervised to ensure that they do not play with the appliance.

Consult with installation contractor for cleaning the inside of the air conditioner.

Wrong cleaning may make the plastics parts broken or cause failure of water leakage or electric shock.

Do not touch the air inlet or aluminium fin of the air conditioner.

Otherwise, injury may be caused.

Do not place objects in direct proximity of the outdoor unit and do not let leaves and other debris accumulate around the unit.

Leaves are a hotbed for small animals which can enter the unit. Once in the unit, such animals can cause malfunctions, smoke or fire when making contact with electrical parts.

1-2 Specifications

[Single unit]

Model	RXYQ5PY1	RXYQ8PY1	RXYQ10PY1
Power supply			
Phase	-	3N~	3N~
Frequency (Hz)	50	50	50
Voltage (V)	380-415	380-415	380-415
Nominal cooling capacity (kW)	14.0	22.4	28.0
Nominal heating capacity (kW)	16.0	25.0	31.5
Dimensions H×W×D (mm)	1680×635×765	1680×930×765	1680×930×765
Mass (kg)	160	205	249
Refrigerant type	-	R-410A	R-410A
Refrigerant charge (*1) (kg)	6.2	7.7	8.4
Design pressure			
High pressure side (bar)	40	40	40
(MPa)	4.0	4.0	4.0
Low pressure side (bar)	33	33	33
(MPa)	3.3	3.3	3.3

Model	RXYQ12PY1	RXYQ14PY1	RXYQ16PY1
Power supply			
Phase	-	3N~	3N~
Frequency (Hz)	50	50	50
Voltage (V)	380-415	380-415	380-415
Nominal cooling capacity (kW)	33.5	40.0	45.0
Nominal heating capacity (kW)	37.5	45.0	50.0
Dimensions H×W×D (mm)	1680×1240×765	1680×1240×765	1680×1240×765
Mass (kg)	285	329	329
Refrigerant type	-	R-410A	R-410A
Refrigerant charge (*1) (kg)	10.0	12.3	12.5
Design pressure			
High pressure side (bar)	40	40	40
(MPa)	4.0	4.0	4.0
Low pressure side (bar)	33	33	33
(MPa)	3.3	3.3	3.3

Model	RXYQ18PY1
Power supply	
Phase	-
Frequency (Hz)	50
Voltage (V)	380-415
Nominal cooling capacity (kW)	49.0
Nominal heating capacity (kW)	56.5
Dimensions H×W×D (mm)	1680×1240×765
Mass (kg)	341
Refrigerant type	-
Refrigerant charge (*1) (kg)	12.7
Design pressure	
High pressure side (bar)	40
(MPa)	4.0
Low pressure side (bar)	33
(MPa)	3.3

Model	RXQ5PY1	RXQ8PY1	RXQ10PY1
Power supply			
Phase	-	3N~	3N~
Frequency (Hz)	50	50	50
Voltage (V)	380-415	380-415	380-415
Nominal cooling capacity (kW)	14.0	22.4	28.0
Dimensions H×W×D (mm)	1680×635×765	1680×930×765	1680×930×765
Mass (kg)	160	205	249
Refrigerant type	-	R-410A	R-410A
Refrigerant charge (*1) (kg)	6.2	7.7	8.4
Design pressure			
High pressure side (bar)	40	40	40
(MPa)	4.0	4.0	4.0
Low pressure side (bar)	33	33	33
(MPa)	3.3	3.3	3.3

Model	RXQ12PY1	RXQ14PY1	RXQ16PY1
Power supply			
Phase	-	3N~	3N~
Frequency (Hz)	50	50	50
Voltage (V)	380-415	380-415	380-415
Nominal cooling capacity (kW)	33.5	40.0	45.0
Dimensions H×W×D (mm)	1680×1240×765	1680×1240×765	1680×1240×765
Mass (kg)	285	329	329
Refrigerant type	-	R-410A	R-410A
Refrigerant charge (*1) (kg)	10.0	12.3	12.5
Design pressure			
High pressure side (bar)	40	40	40
(MPa)	4.0	4.0	4.0
Low pressure side (bar)	33	33	33
(MPa)	3.3	3.3	3.3

Model	RXQ18PY1
Power supply	
Phase	-
Frequency (Hz)	50
Voltage (V)	380-415
Nominal cooling capacity (kW)	49.0
Dimensions H×W×D (mm)	1680×1240×765
Mass (kg)	341
Refrigerant type	-
Refrigerant charge (*1) (kg)	12.7
Design pressure	
High pressure side (bar)	40
(MPa)	4.0
Low pressure side (bar)	33
(MPa)	3.3

*1:Initial refrigerant charge

[Combination unit]

RXYQ20~54PY1 or RXQ20~54PY1 is the combination unit that is composed of the single units.

About the specifications see **Single unit** according to the independent unit.

1-3 What to do before Operation

This operation manual is for the following system with standard control. Before initiating operation, contact your Daikin dealer for the operation that corresponds to your system type and mark. If your installation has a customized control system, ask your Daikin dealer for the operation that corresponds to your system.

Outdoor units (Refer to figure 1)

	Cool/Heat selector	Operation modes
Inverter series		
heat pumps RXYQ series	<input type="checkbox"/> yes <input type="checkbox"/> no	☀️ 🌬️ 🔄
cooling only RXQ series	_____	☀️ 🌬️ 🔄

- Names and functions of parts (Refer to figure 1)

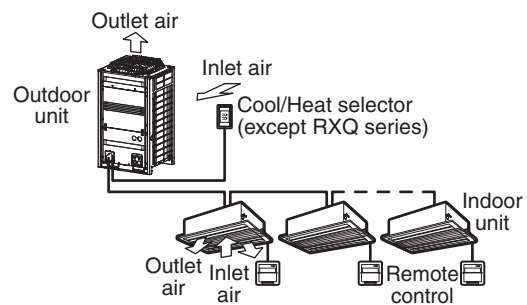

figure 1

(figure 1 shows system with Cool/Heat selector)

**1-4 Remote Control and COOL/HEAT Selector:
Name and Function of Each Switch and Display
(Refer to figure 2 and 3)**

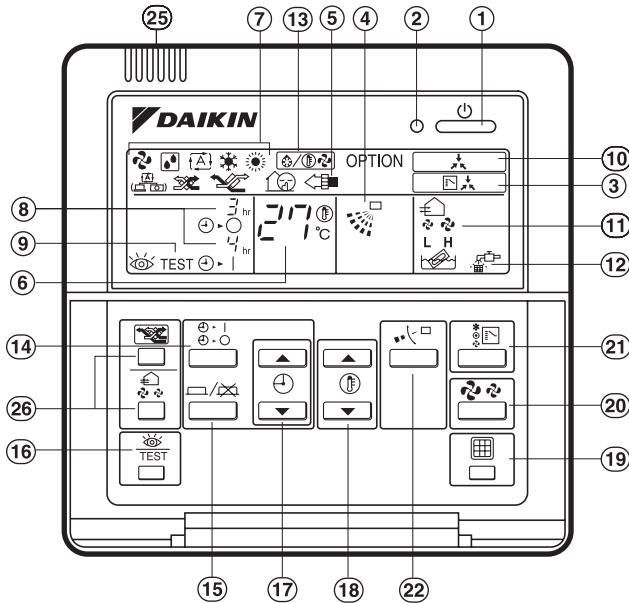

figure 2

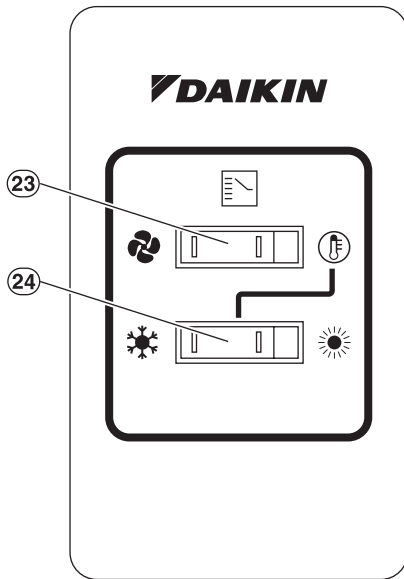

















figure 3

- 1. On/off button**
Press the button and the system will start. Press the button again and the system will stop.
- 2. Operation lamp (red)**
The lamp lights up during operation.
- 3. Display “” (changeover under control)**
It is impossible to changeover heat/cool with the remote control which display this icon.
- 4. Display “” (air flow flap)**
Refer to the chapter “Operation procedure - Adjusting the air flow direction”.
- 5. Display “OPTION” (ventilation/air cleaning)**
This display shows that the ventilation unit are in operation. (these are optional accessories)
- 6. Display “” (set temperature)**
This display shows the temperature you have set.
- 7. Display “” (operation mode)**
This display shows the current operation mode.
- 8. Display “” (programmed time)**

This display shows the programmed time of the system start or stop.

- 9. Display “ TEST” (inspection/test operation)**
When the inspection/test operation button is pressed, the display shows the mode in which the system actually is.
- 10. Display “” (under centralized control)**
When this display shows, the system is under centralized control. (This is not a standard specification.)
- 11. Display “” (fan speed)**
This display shows the fan speed you have selected.
- 12. Display “” (time to clean air filter)**
Refer to the operation manual of indoor unit.
- 13. Display “” (defrost/hot start)**
Refer to the chapter “Operation procedure - Explanation of heating operation.”
- 14. Timer mode start/stop button**
Refer to the chapter “Operation procedure - Programming start and stop of the system with timer.”
- 15. Timer on/off button**
Refer to the chapter “Operation procedure - Programming start and stop of the system with timer.”
- 16. Inspection/test operation button**
This button is only used by qualified service persons for maintenance purposes.
- 17. Programming time button**
Use this button for setting the programming start and/or stop time.
- 18. Temperature setting button**
Use this button for setting the desired temperature.
- 19. Filter sign reset button**
Refer to the operation manual of indoor unit.
- 20. Fan speed control button**
Press this button to select the fan speed of your preference.
- 21. Operation mode selector button**
Press this button to select the operation mode of your preference.
- 22. Air flow direction adjust button**
Refer to the chapter “Operation procedure - Adjusting the air flow direction”.
- 23. Fan only/air conditioning selector switch**
Set the switch to “” for fan only operation or to “” for heating or cooling operation.
- 24. Cool/heat changeover switch**
Set the switch to “” for cooling operation or to “” for heating operation.
- 25. Thermistor**
It sense the room temperature around the remote control.
- 26. These button are used when the ventilation unit are installed (These are optional accessories)**
Refer to the operation manual of the ventilation unit.

Note

- In contradistinction to actual operating situations, the display on figure 1 shows all possible indications.
- Figure 2 shows the remote control which is opened the cover.
- For FXS, FXM, FXL and FXN, the air flow direction adjust button (22) is not available and the display (4) shows “NOT AVAILABLE” when pressed.

1-5 Operation Range

Use the system in the following temperature and humidity ranges for safe and effective operation.

	COOLING	HEATING*
outdoor temperature	-5°~43°CDB	-20°~21°CDB -20°~15.5°CWB
indoor temperature	21°~32°CDB	15°~27°CDB
indoor humidity	≤ 80%	

*Except RXQ series





Note

To avoid condensation and water dripping out the unit. If the temperature or the humidity is beyond these conditions, safety devices may work and the air conditioner may not operate.

1-6 Operation Procedure

- Operation procedure varies according to the combination of outdoor unit and remote control. Read the chapter “What to do before operation”.
- To protect the unit, turn on the main power switch 6 hours before operation.
And do not turn off the power supply during the air conditioning season because of smoothly start up.
- If the main power supply is turned off during operation, operation will restart automatically after the power turns back on again.

1-6-1 Cooling, Heating and Fan only Operation

- The operation mode cannot be changed with the remote control whose display shows “” (changeover under control).
Change the operation mode with the remote control whose display does not show “”.
- When the display “” (changeover under control) flashes, refer to the chapter “Operation procedure - Setting the master remote control”.
- In case of RXQ series, the displays shows “”. However, the operation mode can be changed between cooling operation and fan only operation.
- The fan may keep on running for about 1 minute after the heating operation stops for removing the heat in the indoor unit.
- The air flow rate may be adjusted automatically depending on the room temperature or the fan may stop immediately. This is not a malfunction.
- For machine protection the system may control the air flow rate automatically.
- It may take sometime for finishing to change the air flow rate. This is normal operation.

FOR SYSTEMS WITHOUT COOL/HEAT SELECTOR (Refer to figure 4)

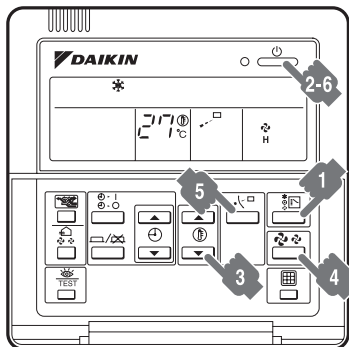





figure 4

- 1 Press the operation mode selector button several times and select the operation mode of your choice;
 - “” Cooling operation
 - “” Heating operation (except RXQ series)
 - “” Fan only operation
- 2 Press the on/off button.
The operation lamp lights up and the system starts operation.

FOR SYSTEMS WITH COOL/HEAT SELECTOR (except RXQ series) (Refer to figure 4 and 7)

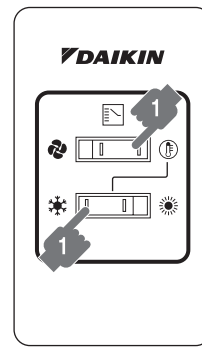

figure 7.1

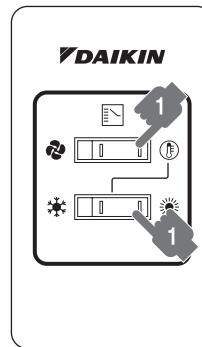

figure 7.2

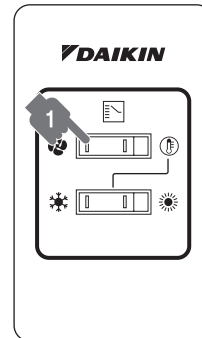







figure 7.3

- 1 Select operation mode with the Cool/Heat selector as follows:
 - “” “” Cooling operation (Refer to figure 7.1)
 - “” “” Heating operation (Refer to figure 7.2)
 - “” Fan only operation (Refer to figure 7.3)
- 2 Press the on/off button. (Refer to figure 4)
The operation lamp lights up and the system starts operation.

ADJUSTMENT (Refer to figure 4)

For adjustment the desired temperature, fan speed and air flow direction (only for the remote control BRC1A51: FXC, FXF, FXH, FXK, FXA), follow the procedure shown below.

- 3 Press the temperature setting button and set the desired temperature.
Each time this button is pressed, the temperature setting rises or lowers 1°C.



Note

- Set the temperature within the operation range.
 - The temperature setting is impossible for fan only operation.
- 4 Press the fan speed control button and select the fan speed of your preference.

- 5 Press air flow direction adjust button.
Refer to the chapter "Adjusting the air flow direction" for details.

STOPPING THE SYSTEM (Refer to figure 4)

- 6 Press the on/off button once again.
The operation lamp goes off and the system stops operation.

Note

- Do not turn off the power immediately after the unit stops.
- The system need at least 5 minutes for residual operation of drain pump device.
Turning off the power immediately will cause water leak or trouble.

EXPLANATION OF HEATING OPERATION (except RXQ series)

- For general heating operation, it may take longer to reach the set temperature than in cooling operation.
We recommend starting the operation which was used before using timer operation.
- The following operation is performed in order to prevent the heating capacity from dropping or cold air from blowing.

Defrost operation

- In heating operation, freezing of the outdoor unit heat exchanger increases. Heating capability decreases and the system goes into defrost operation.
- The indoor unit fan stops and the remote control displays "❄️".
- After maximum 10 minutes of defrost operation, the system returns to heating operation again.

Hot start

- In order to prevent cold air from blowing out of an indoor unit at the start of heating operation, the indoor fan is automatically stopped. The display of the remote control shows "❄️".

Note

- The heating capacity drops as the outside temperature falls. If this happens, use another heating device together with the unit. (When using the appliances which produce open fire together, ventilate a room constantly.)
Do not place appliances which produce open fire in places exposed to the air flow from the unit or under the unit.
- It takes some time for the room to warm up from the time the unit is started since the unit uses a hot-air circulatory system to warm the entire room.
- If the hot air rises to the ceiling, leaving the area above the floor cold, we recommend using the circulator (the indoor fan for circulating air). Contact your dealer for details.

1-6-2 Program Dry Operation

- The function of this operation is to decrease the humidity in your room with a minimum temperature decrease.
- The micro computer automatically determines temperature and fan speed.
- The system does not go into operation if the room temperature is low.
- The microcomputer automatically controls the temperature and fan speed, so these cannot be set using the remote control.
- This function is not available if the room temperature is 20°C or lower.

FOR SYSTEMS WITHOUT COOL/HEAT SELECTOR (Refer to figure 5)

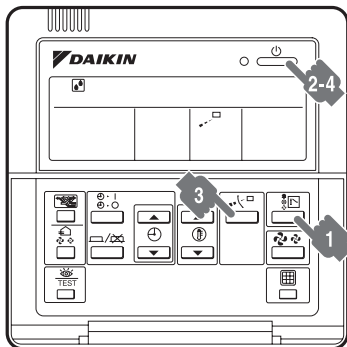

figure 5

- 1 Press the operation mode selector button several times and select "☁️" (program dry operation).

- 2 Press the on/off button.
The operation lamp lights up and the system starts operation.
- 3 Press the air flow direction adjust button (only for FXC, FXF, FXH, FXK, FXA). Refer to the chapter "Adjusting the air flow direction" for details.
- 4 Press the on/off button once again.
The operation lamp goes off and the system stops operation.

Note

- Do not turn off the power immediately after the unit stops.
- The system need at least 5 minutes for residual operation of drain pump device.
Turning off the power immediately will cause water leak or trouble.

FOR SYSTEMS WITH COOL/HEAT SELECTOR (except RXQ series) (Refer to figure 8)

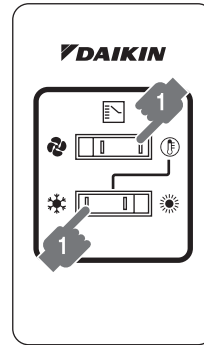

figure 8

- 1 Select cooling operation mode with the Cool/Heat selector.
- 2 Press the operation mode selector button several times and select program dry "☁️".
- 3 Press the on/off button.
The operation lamp lights up and the system starts operation.
- 4 Press the air flow direction adjust button (only for FXC, FXF, FXH, FXK, FXA). Refer to the chapter "Adjusting the air flow direction" for details.
- 5 Press the on/off button once again.
The operation lamp goes off and the system stops operation.

Note

- Do not turn off the power immediately after the unit stops.
- The system need at least 5 minutes for residual operation of drain pump device.
Turning off the power immediately will cause water leak or trouble.

1-6-3 Adjusting the Air Flow Direction (Refer to figure 6) (only for Double-flow, Multi-flow, Corner, Ceiling-suspended and Wall-mounted)

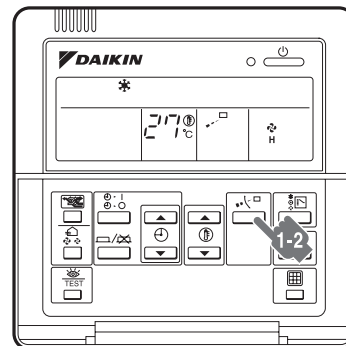

figure 6

- 1 Press the air flow direction button to select the air direction.
The air flow flap display swings as shown right and the air flow direction continuously varies. (Automatic swing setting)
- 2 Press the air flow direction adjust button to select the air direction of your choice.



The air flow flap display stops swinging and the air flow direction is fixed. (Fixed air flow direction setting)

MOVEMENT OF THE AIR FLOW FLAP

For the following conditions, a micro computer controls the air flow direction which may be different from the display.

COOLING	HEATING
	<ul style="list-style-type: none"> • When starting operation. • When the room temperature is higher than the set temperature. • At defrost operation.
<ul style="list-style-type: none"> • When operating continuously at horizontal air flow direction. • When continuous operation with downward air flow is performed at the time of cooling with a ceiling-suspended or a wall-mounted unit, the microcomputer may control the flow direction, and then the remote control indication also will change. 	

The air flow direction can be adjusted in one of the following ways.

- The air flow flap itself adjusts its position.
- The air flow direction can be fixed by the user.

Automatic “” or desired position “”.

(Refer to figure 13)

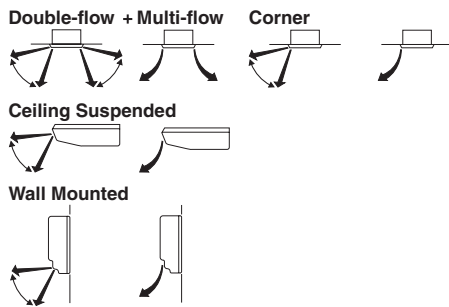

figure 13

Note

- The movable limit of the flap is changeable. Contact your Daikin dealer for details. (Only for Double-flow, Multi-flow, Corner, Ceiling-suspended and Wall-mounted.)
- Avoid operating in the horizontal direction “”. It may cause dew or dust to settle on the ceiling.

1-6-4 Programming Start and Stop of the System with Timer
(Refer to figure 9)

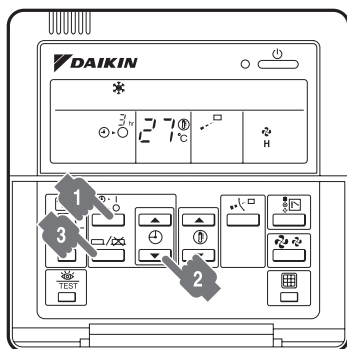

figure 9

- The timer is operated in the following two ways.
Programming the stop time “ ◻ ◻ ”. The system stops operating after the set time has elapsed.
Programming the start time “ ◻ | ”. The system starts operating after the set time has elapsed.
- The timer can be programmed for a maximum of 72 hours.
- The start and the stop time can be simultaneously programmed.

1 Press the timer mode start/stop button several times and select the mode on the display. The display flashes.

- For setting the timer stop “ ◻ ◻ ”
- For setting the timer start “ ◻ | ”

2 Press the programming time button and set the time for stopping or starting the system.

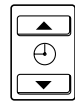

Each time this button is pressed, the time advances or goes backward by 1 hour.

3 Press the timer on/off button. The timer setting procedure ends. The display “ ◻ ◻ ” or “ ◻ | ” changes from flashing light to constant light.

Note

- When setting the timer off and on at the same time, repeat the above procedure (from “**1**” to “**3**”) once again.
- After the timer is programmed, the display shows the remaining time.
- Press the timer on/off button once again to cancel programming. The display vanishes.

For example: (Refer to figure 11)

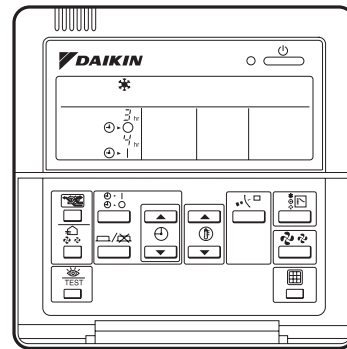

figure 11

When the timer is programmed to stop the system after 3 hours and start the system after 4 hours, the system will stop after 3 hours and start 1 hour later.

1-6-5 Setting the Master Remote Control (except RXQ series)
(Refer to figure 10)

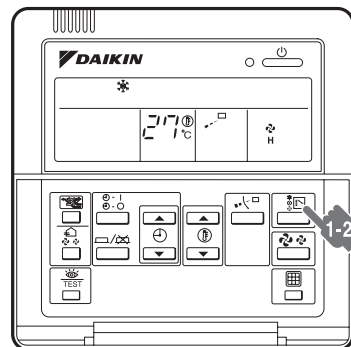

figure 10

- When one outdoor unit is connected with several indoor units as shown in figure 14, it is necessary to designate one of the remote controls as the master remote control.

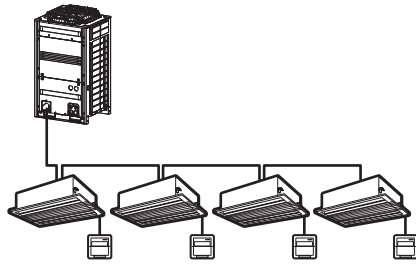
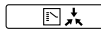
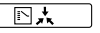

figure 14

- Only the master remote control can select heating, cooling operation.
- The displays of slave remote controls show "  " (changeover under control) and they automatically follow the operation mode directed by the master remote control. However, it is possible to changeover to program dry with slave remote controls if the system is in cooling operation by setting on the master remote control and to changeover to fan only operation.

How to designate the master remote control

- Press the operation mode selector button of the current master remote control for 4 seconds.

The display showing "  " (changeover under control) of all slave remote controls connected to the same outdoor unit flashes.

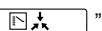
- Press the operation mode selector button of the controller that you wish to designate as the master remote control. Then designation is completed. This remote control is designated as the master remote control and the display showing "  " (changeover under control) vanishes.

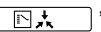
The displays of other remote controls show "  " (changeover under control).

1-6-6 Precautions for Group Control System or Two Remote Control Control System

This system provides two other control systems beside individual control (one remote control controls one indoor unit) system. Confirm about your system to Daikin dealer.

- Group control system**
One remote control controls up to 16 indoor units. All indoor units are equally set.
- Two remote control control system**
Two remote controls control one indoor unit (in case of group control system, one group of indoor units). The unit is individually operated.

Note

- Contact your Daikin dealer in case of changing the combination or setting of group control and two remote control systems.

1-7 Optimum Operation

Observe the following precautions to ensure the system operates properly.

- Adjust the air outlet properly and avoid direct air flow to room inhabitants.
- Adjust the room temperature properly for a comfortable environment. Avoid excessive heating or cooling.
- Prevent direct sunlight from entering a room during cooling operation by using curtains or blinds.
- Ventilate often.
Extended use requires special attention to ventilation.
- Do not keep doors and windows opened. If the doors and windows remain open, air will flow out of your room causing a decrease in the cooling or heating effect.
- Never place objects near the air inlet or the air outlet of the unit. It may cause deterioration in the effect or stop the operation.

- Turn off the main power supply switch to the unit when the unit is not used for longer periods of time. If the switch is on, it uses electricity. Before restarting the unit, turn on the main power supply switch 6 hours before operation to ensure smooth running. (Refer to the chapter "Maintenance" in the indoor unit manual.)
- When the display shows "  " (time to clean the air filter), ask a qualified service person to clean the filters. (Refer to the chapter "Maintenance" in the indoor unit manual.)
- Keep the indoor unit and remote control at least 1 m away from televisions, radios, stereos, and other similar equipment. Failing to do so may cause static or distorted pictures.
- Do not use other heating devices directly beneath the indoor unit. If you do, they might get deformed by the heat.

1-8 Seasonal Maintenance

1-8-1 At the Beginning of the Season

Check

- Are the indoor and outdoor unit intake and outlet vents blocked? Remove anything that might be blocking them.

Clean the air filter and exterior.

- After cleaning the air filter, be sure to put it back in the same position.
See the operation manual included with the indoor unit for details on how to clean it.

Turn the power on.

- When the power comes on, the characters in the remote control display appear.
(To protect the unit, turn the power on at least 6 hours before operating it. This makes operation smoother.)

1-8-2 At the End of the Season

On a clear day, use fan operation for around half a day to thoroughly dry out the interior of the unit.

- Refer to page 5 for details on fan operation.

Turn off the power

- When the power is shut off, the characters in the remote control display disappear.
- When the power is on, the unit consumes up to several dozen Watts of power.
Turn off the power to conserve energy.

Clean the air filter and exterior.

- After cleaning the air filter, be sure to put it back in the same position.
See the operation manual included with the indoor unit for details on how to clean it.

1-9 Following Symptoms are not Air Conditioner Troubles

1-9-1 The System does not Operate

- The air conditioner does not start immediately when restart the operation after stop the operation or change operation mode after set the operation mode.**
If the operation lamp lights, the system is in normal condition.
To prevent overloading of the compressor motor, the air conditioner starts 5 minutes after it is turned ON again in case it was turned OFF just before.
- If "Centralized Control" is displayed on the remote control and pressing the operation button causes the display to blink for a few seconds.**
This indicates that the central device is controlling the unit. The blinking display indicates that the remote control cannot be used.
- The system does not start immediately after the power supply is turned on.**
Wait one minute until the micro computer is prepared for operation.

1-9-2 It Stops Sometimes

- The remote control display reads "U4" or "U5" and stops but then restarts after a few minutes.**
This is because the remote control is intercepting noise from electrical appliances other than the air conditioner, and this prevents communication between the units, causing them to stop. Operation automatically restarts when the noise goes away.

1-9-3 COOL/HEAT cannot be Changed Over

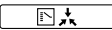
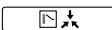
- **When the display shows “  ” (changeover under control).**
It shows that this is a slave remote control.
Refer to “Setting the master remote control”.
- **When the cool/heat selector switch is installed and the display shows “  ” (changeover under control).**
This is because cool/heat changeover is controlled by the cool/heat selector. Ask your Daikin dealer where the remote control switch is installed.

1-9-4 Fan Operation is Possible, but Cooling and Heating do not Work

- **Immediately after the power is turned on.**
The micro computer is getting ready to operate.
Wait 10 minutes.

1-9-5 The Fan Strength does not Correspond to the Setting

- **The fan strength does no change even if the fan strength adjustment button is pressed.**
During heating operation, when the room temperature reaches the set temperature, the outdoor unit goes off and the indoor unit changes to whisper fan strength.
This is to prevent cold air blowing directly on occupants of the room.
The fan strength will not change even if the button is changed, when another indoor unit is in heating operation.

1-9-6 The Fan Direction does not Correspond to the Setting

- **The fan direction does not correspond to the remote control display.**
The fan direction does not swing.
This is because the unit is being controlled by the micro computer.
Refer to “Adjusting the air flow direction”.

1-9-7 White Mist Comes Out of a Unit

Indoor unit

- **When humidity is high during cooling operation.**
If the interior of an indoor unit is extremely contaminated, the temperature distribution inside a room becomes uneven. It is necessary to clean the interior of the indoor unit. Ask your Daikin dealer for details on cleaning the unit. This operation requires a qualified service person.
- **Immediately after the cooling operation stops and if the room temperature and humidity are low.**
This is because warm refrigerant gas flows back into the indoor unit and generates steam.

Indoor unit, outdoor unit

- **When the system is changed over to heating operation after defrost operation.**
Moisture generated by defrost becomes steam and is exhausted.

1-9-8 Noise of Air Conditioners

Indoor unit

- **A “zeen” sound is heard immediately after the power supply is turned on.**
The electronic expansion valve inside an indoor unit starts working and makes the noise. Its volume will reduce in about one minute.
- **A continuous low “shah” sound is heard when the system is in cooling operation or at a stop.**
When the drain pump (optional accessories) is in operation, this noise is heard.
- **A “pishi-pishi” squeaking sound is heard when the system stops after heating operation.**
Expansion and contraction of plastic parts caused by temperature change make this noise.
- **A low “sah”, “choro-choro” sound is heard while the indoor unit is stopped.**
When the other indoor unit is in operation, this noise is heard. In order to prevent oil and refrigerant from remaining in the system, a small amount of refrigerant is kept flowing.

Outdoor unit

- **When the tone of operating noise changes.**
This noise is caused by the change of frequency.

Indoor unit, outdoor unit

- **A continuous low hissing sound is heard when the system is in cooling or defrost operation.**
This is the sound of refrigerant gas flowing through both indoor and outdoor units.
- **A hissing sound which is heard at the start or immediately after stopping operation or defrost operation.**
This is the noise of refrigerant caused by flow stop or flow change.

1-9-9 Dust Comes Out of the Unit

- **When the unit is used after stopping for a long time.**
This is because dust has gotten into the unit.

1-9-10 The Units can Give off Odours

- **During operation.**
The unit can absorb the smell of rooms, furniture, cigarettes, etc., and then emit it again.

1-9-11 The Outdoor Unit Fan does not Spin

- **During operation.**
The speed of the fan is controlled in order to optimize product operation.

1-9-12 The Display Shows “ ”

- **This is the case immediately after the main power supply switch is turned on.**
This means that the remote control is in normal condition. This continues for one minute.

1-9-13 The Compressor or Fan in the Outdoor Unit does not Stop

- **This is to prevent oil and refrigerant from remaining in the compressor. The unit will stop after 5 to 10 minutes.**

1-9-14 The Inside of an Outdoor Unit is Warm even when the Unit has Stopped

- **This is because the crankcase heater is warming the compressor so that the compressor can start smoothly.**

1-9-15 It Stops Sometimes

- **The remote control display reads “U4” and “U5” and stops but then restarts after a few minutes.**
This is because the remote control is intercepting noise from electrical appliances other than the air conditioner, and this prevents communication between the units, causing them to stop.
Operation automatically restarts when the noise goes away.

1-9-16 Hot Air is Emitted even though the Unit is Stopped

- **Hot air can be felt when the unit is stopped.**
Several different indoor units are being run on the same system, so if another unit is running, some refrigerant will still flow through the unit.

1-9-17 Does not Cool very well

- **Program dry operation.**
Program dry operation is designed to lower the room temperature as little as possible.
Refer to page 315.

1-10 Trouble Shooting

If one of the following malfunctions occur, take the measures shown below and contact your Daikin dealer.

Warning

Stop operation and shut off the power if anything unusual occurs (burning smells, etc.)

Leaving the unit running under such circumstances may cause breakage, electrical shock, or fire.
Contact your dealer.

- If a safety device such as a fuse, a breaker or an earth leakage breaker frequently actuates;
Measure : Do not turn on the main power switch.
- If the ON/OFF switch does not properly work;
Measure: Turn off the main power switch.
- If water leaks from unit;
Measure: Stop the operation.
- The operation switch does not work well.
Turn off the power.
- If the display “ TEST”, the unit number and the operation lamp flash and the malfunction code appears; (Refer to figure 12)

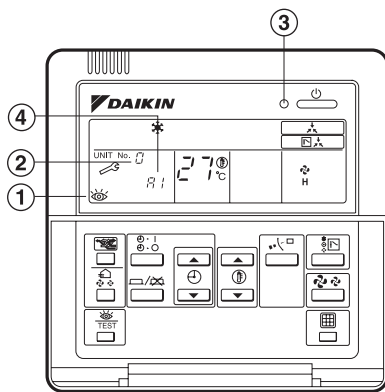

figure 12

1. Inspection display
2. Indoor unit number in which a malfunction occurs
3. Operation lamp
4. Malfunction code

Measure: Notify your Daikin dealer and report the malfunction code.

If the system does not properly operate except for the above mentioned cases and none of the above mentioned malfunctions is evident, investigate the system according to the following procedures.

If it is impossible to fix the problem yourself after checking all the above items, contact your dealer.

Let him know the symptoms, system name, and model name (listed on the warranty card).

1. If the system does not operate at all;
 - Check if there is no power failure.
Wait until power is restored. If power failure occurs during operation, the system automatically restarts immediately after the power supply is recovered.
 - Check if no fuse has blown;
Turn off the power supply
 - Check if the breaker is blown.
Turn the power on with the breaker switch in the off position.
Do not turn the power on with the breaker switch in the trip position.
(Contact your dealer.)

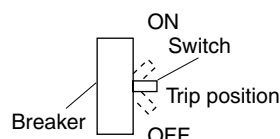

2. If the system stops soon after starting the operation;
 - Check if air inlet or outlet of outdoor or indoor unit is not blocked by obstacles.
Remove any obstacle and make it well-ventilated.
 - Check if the remote control display shows “ ” (time to clean the air filter);
Refer to the operation manual of the indoor unit. And clean the air filter.

3. The system operates but cooling or heating is insufficient;
 - Check if air inlet or outlet of outdoor or indoor unit is not blocked by obstacles.
Remove any obstacle and make it well-ventilated.
 - Check if the remote control display shows “ ” (time to clean the air filter);
Refer to the operation manual of the indoor unit. And clean the air filter.
 - Check the temperature setting.
Refer to “Operation procedure”.
 - Check the fan speed setting on your remote control.
Refer to “Operation procedure”.
 - Check for open doors or windows.
Shut doors and windows to prevent wind from coming in.
 - Check if there are too many occupants in the room during cooling operation.
 - Check if the heat source of the room is excessive during cooling operation.
 - Check if direct sunlight enters the room during cooling operation.
Use curtains or blinds.
 - Check if the air flow angle is not proper.
Refer to “Operation procedure”.

After-sales service and warranty

After-sales service:

Warning

- **Do not modify the unit.**
This may cause electric shock or fire.
 - **Do not disassemble or repair the unit.**
This may cause electric shock or fire.
Contact your dealer.
 - **If the refrigerant leaks, keep out of fire.**
Although the refrigerant does not usually leak, if the refrigerant leaks out into a room and comes in contact with the combustible air in the equipment such as fan heater, stove, oil (gas) cooker, etc., it will cause toxic gas to be generated.
When a refrigerant leakage failure has been repaired, confirm a service person that the leakage point has been corrected surely before restarting operation.
 - **Do not remove or reinstall the unit by yourself.**
Incorrect installation may cause electrical shock or fire.
Contact your dealer.
-
- **When asking your dealer to repair, inform related staff of the details as follows:**
 - Product No. of air conditioner:
Refer to the warranty card.
 - Shipping date and installation date:
Refer to the warranty card.
 - Malfunction:
Inform the staff of the defective details.
(Malfunction code being displayed on the remote control.)
 - Name, address, telephone number
 - **Repair where the warranty term is expired**
Contact your dealer. If necessary to repair, pay service is available.
 - **Minimum storage period of important parts**
Even after a certain type of air conditioner is discontinued, we have the related important parts in stock for 9 years at least.
The important parts indicate parts essential to operate the air conditioner.
 - **Recommendations for maintenance and inspection**
Since dust collects after using the unit for several years, the performance will be deteriorated to some extent.
Taking apart and cleaning inside require technical expertise, so we recommend entering a maintenance and inspection contract (at a cost) separate from normal maintenance.
 - **Recommended inspection and maintenance cycles**
[Note: The maintenance cycle is not the same as the warranty period.]
Table 1 assumes the following usage conditions.
 1. Normal use without frequent starting and stopping of the machine.
(Although it varies with the model, we recommend not starting and stopping the machine more than 6 times/hour for normal use.)
 2. Operation of the product is assumed to be 10 hours/day, 2500 hours/year.

• Table 1 “Inspection Cycle” and “Maintenance Cycle” Lists

Name of Main Part	Inspection Cycle	Maintenance Cycle [replacements and/or repairs]
Electric motor (fan, damper, etc.)	1 year	20,000 hours
PC boards		25,000 hours
Heat exchanger		5 years
Sensor (thermistor, etc.)		5 years
remote control and switches		25,000 hours
Drain pan		8 years
Expansion valve		20,000 hours
Electromagnetic valve		20,000 hours

Note 1

This table indicates main parts. See the maintenance and inspection contract for details.

Note 2

This maintenance cycle indicates recommended lengths of time until the need arises for maintenance work, in order to ensure the product is operational as long as possible. Use for appropriate maintenance design (budgeting maintenance and inspection fees, etc.) Depending on the content of the maintenance and inspection contract, the inspection and maintenance cycles may in reality be shorter than those listed here.

Shortening of “maintenance cycle” and “replacement cycle” needs to be considered in the following cases.

1. When used in hot, humid locations or locations where temperature and humidity fluctuate greatly.
2. When used in locations where power fluctuation (voltage, frequency, wave distortion, etc.) is high. (Cannot be used if it is outside the allowable range.)
3. When installed and used in locations where bumps and vibrations are frequent.
4. When used in bad locations where dust, salt, harmful gas or oil mist such as sulfurous acid and hydrogen sulfide may be present in the air.
5. When used in locations where the machine is started and stopped frequently or operation time is long. (Example: 24 hour air-conditioning)

■ **Recommended replacement cycle of wear-out parts**

[The cycle is not the same as the warranty period.]

• Table 2 “Replacement Cycle” Lists

Name of Main Part	Inspection Cycle	Replacement Cycle
Air filter	1 year	5 years
High efficiency filter (Optional accessory)		1 year
Fuse		10 years
Crankcase heater		8 years

Note 1

This table indicates main parts. See the maintenance and inspection contract for details.

Note 2

This maintenance cycle indicates recommended lengths of time until the need arises for maintenance work, in order to ensure the product is operational as long as possible. Use for appropriate maintenance design (budgeting maintenance and inspection fees, etc.).

Contact your dealer for details.

Note: Breakage due to taking apart or cleaning inside by anyone other than our authorized dealers may not be included in the warranty.

■ **Moving and discarding the unit**

- Contact your dealer for removing and reinstalling the system air conditioner since they require technical expertise.
- The system air conditioner uses fluorocarbon refrigerant. Contact your dealer for discarding the system air conditioner since it is required by law to collect, transport and discard the refrigerant in accordance with relevant local and national regulations.

■ **Where to call**

For after-sales service, etc., consult with your dealer.

■ **Warranty period:**

- This product includes a warranty card. The warranty card is given to a customer after dealer staff fills out necessary items in the card. The customer should check the entered items and store it carefully. Warranty period: Within one year after installation. For further details, refer to the warranty card.
- If it is necessary to repair the air conditioner within the warranty period, contact your dealer and show your warranty card. If the warranty card is not shown, pay-service repair may be performed even though the warranty period is not expired.

2. Heat Pump 60Hz (RXYQ5~54P)

DAIKIN



OPERATION MANUAL

VRV III System air conditioner

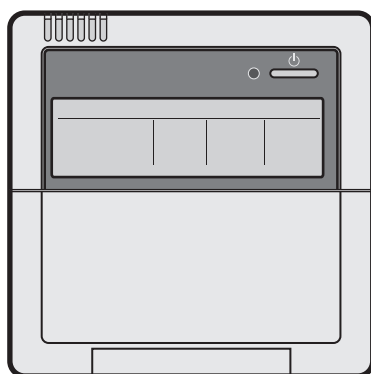

Operation manual
VRV III System air conditioner

English

Manual de operación
Sistema de acondicionador de aire VRV III

Español

Manual de funcionamento
Ar condicionado VRV III System

Portugues

使用説明書
VRV III 係統空調機

中文
(繁體)

RXYQ5PYL(E)
RXYQ8PYL(E)
RXYQ10PYL(E)
RXYQ12PYL(E)
RXYQ14PYL(E)
RXYQ16PYL(E)
RXYQ18PYL(E)
RXYQ20PYL(E)
RXYQ22PYL(E)
RXYQ24PYL(E)
RXYQ26PYL(E)
RXYQ28PYL(E)
RXYQ30PYL(E)
RXYQ32PYL(E)
RXYQ34PYL(E)
RXYQ36PYL(E)
RXYQ38PYL(E)
RXYQ40PYL(E)
RXYQ42PYL(E)
RXYQ44PYL(E)
RXYQ46PYL(E)
RXYQ48PYL(E)
RXYQ50PYL(E)
RXYQ52PYL(E)
RXYQ54PYL(E)

2-1 Safety Cautions

Read the following cautions carefully and use your equipment properly.

There are two kinds of safety cautions and tips listed here as follows:

 **Warning** Improper handling can lead to such serious consequences as death or severe injury.

 **Caution**..... Improper handling can lead to injury or damage. It could also have serious consequences under certain conditions.

Note 

Keep this operation manual handy so that you can refer to them if needed.

Also, if this equipment is transferred to a new user, make sure to hand over this operation manual to the new user.

 **Warning**

It is not good for your health to expose your body to the air flow for a long time.

In order to avoid electric shock, fire or injury, or if you detect any abnormality such as smell of fire, turn off power and call your dealer for instructions.

Ask your dealer for installation of the air conditioner.

Incomplete installation performed by yourself may result in a water leakage, electric shock, and fire.

Ask your dealer for improvement, repair, and maintenance.

Incomplete improvement, repair, and maintenance may result in a water leakage, electric shock, and fire.

Do not put a finger, a rod or other objects into the air inlet or outlet. As the fan is rotating at high speed, it will cause injury. Never touch the air outlet or the horizontal blades while the swing flap is in operation.

Fingers may become caught or the unit may break down.

The refrigerant in the air conditioner is safe and normally does not leak. If the refrigerant leaks inside the room, the contact with a fire of a burner, a heater or a cooker may result in a harmful gas.

Turn off any combustible heating devices, ventilate the room, and contact the dealer where you purchased the unit.

Do not use the air conditioner until when a service person confirms to finish repairing the portion where the refrigerant leaks.

For refrigerant leakage, consult your dealer.

When the air conditioner is to be installed in a small room, it is necessary to take proper measures so that the amount of any leaked refrigerant does not exceed the limiting concentration even when it leaks. If the refrigerant leaks exceeding the level of limiting concentration, an oxygen deficiency accident may happen.

Improper installation or attachment of equipment or accessories could result in electric shock, short-circuit, leaks, fire or other damage to the equipment. Be sure only to use accessories made by Daikin which are specifically designed for use with the equipment and have them installed by a professional.

Ask your dealer to move and reinstall the air conditioner.

Incomplete installation may result in a water leakage, electric shock, and fire.

In order to avoid electric shock, fire, injury or damaging the unit, do not use improper ampere fuses or do not use copper nor steel wires instead.

Be sure to establish an earth.

Do not earth the unit to a utility pipe, arrester, or telephone earth.

Incomplete earth may cause electrical shock, or fire.

A high surge current from lightning or other sources may cause damage to the air conditioner.

Be sure to install an earth leakage breaker.

Failure to install an earth leakage breaker may result in electric shocks, or fire.

 **Caution**

Do not use the air conditioner for other purposes.

In order to avoid any quality deterioration, do not use the unit for cooling precision instruments, food, plants, animals or works of art.

In order to avoid injury, do not remove the fan guard of outdoor unit.

To avoid oxygen deficiency, ventilate the room sufficiently if equipment with burner is used together with the air conditioner.

After a long use, check the unit stand and fitting for damage. If they are left in a damaged condition, the unit may fall and result in injury.

Neither place a flammable spray bottle near the air conditioner nor perform spraying.

Doing so may result in a fire.

Before cleaning, be sure to stop the operation, turn the breaker off.

Otherwise, an electric shock and injury may result.

Do not operate the air conditioner with a wet hand.

An electric shock may result.

Do not place items which might be damaged by moisture under the indoor unit which may be damaged by water.

Condensation may form if the humidity is above 80%, if the drain outlet gets blocked or the filter is polluted.

Do not place appliances which produce open fire in places exposed to the air flow from the unit or under the indoor unit. It may cause incomplete combustion or deformation of the unit due to the heat.

Do not mount on the outdoor unit or avoid placing any object on it.

Falling or tumbling may result in injury.

Never expose little children, plants or animals directly to the air flow.

Adverse influence to little children, animals and plants may result.

Do not wash the air conditioner with water.

Electric shock or fire may result.

Do not install the air conditioner at any place where flammable gas may leak out.

If the gas leaks out and stays around the air conditioner, a fire may break out.

Arrange the drain hose to ensure smooth drainage. Incomplete drainage may cause wetting of the building, furniture etc.

Do not let children play on and around the outdoor unit.

If they touch the unit carelessly, it may result in injury.

Do not place a flower vase or anything containing water on the indoor unit.

Water may enter the unit, causing an electric shock or fire.

Do not place the controller exposed to direct sunlight.

The LCD display may get discolored, failing to display the data.

Do not wipe the controller operation panel with benzine, thinner, chemical dustcloth, etc.

The panel may get discolored or the coating peeled off. If it is heavily dirty, soak a cloth in water-diluted neutral detergent, squeeze it well and wipe the panel clean. And wipe it with another dry cloth.

Never touch the internal parts of the controller.

Do not remove the front panel. Some parts inside are dangerous to touch, and a machine trouble may happen. For checking and adjusting the internal parts, contact your dealer.

Avoid placing the controller in a spot splashed with water.

Water coming inside the machine may cause an electric leak or may damage the internal electronic parts.

Never press the button of the remote control with a hard, pointed object.

The remote control may be damaged.

Never pull or twist the electric wire of a remote control.

It may cause the unit to malfunction.

Do not operate the air conditioner when using a room fumigation - type insecticide.

Failure to observe could cause the chemicals to become deposited in the unit, which could endanger the health of those who are hypersensitive to chemicals.

The appliance is not intended for use by young children or infirm persons without supervision.

Young children should be supervised to ensure that they do not play with the appliance.

Consult with installation contractor for cleaning the inside of the air conditioner.

Wrong cleaning may make the plastics parts broken or cause failure of water leakage or electric shock.

Do not touch the air inlet or aluminium fin of the air conditioner.

Otherwise, injury may be caused.

Do not place objects in direct proximity of the outdoor unit and do not let leaves and other debris accumulate around the unit.

Leaves are a hotbed for small animals which can enter the unit. Once in the unit, such animals can cause malfunctions, smoke or fire when making contact with electrical parts.

2-2 Specifications

[Single unit]

Model	RXYQ5PYL(E)	RXYQ8PYL(E)	RXYQ10PYL(E)
Power supply			
Phase	-	3N~	3N~
Frequency (Hz)	60	60	60
Voltage (V)	380	380	380
Nominal cooling capacity (kW)	14.0	22.4	28.0
Nominal heating capacity (kW)	16.0	25.0	31.5
Dimensions H×W×D (mm)	1680×635×765	1680×930×765	1680×930×765
Mass (kg)	160	205	249
Refrigerant type	-	R-410A	R-410A
Refrigerant charge (*1) (kg)	6.2	7.7	8.4
Design pressure			
High pressure side (bar)	40	40	40
(MPa)	4.0	4.0	4.0
Low pressure side (bar)	33	33	33
(MPa)	3.3	3.3	3.3

Model	RXYQ12PYL(E)	RXYQ14PYL(E)	RXYQ16PYL(E)
Power supply			
Phase	-	3N~	3N~
Frequency (Hz)	60	60	60
Voltage (V)	380	380	380
Nominal cooling capacity (kW)	33.5	40.0	45.0
Nominal heating capacity (kW)	37.5	45.0	50.0
Dimensions H×W×D (mm)	1680×1240×765	1680×1240×765	1680×1240×765
Mass (kg)	285	329	329
Refrigerant type	-	R-410A	R-410A
Refrigerant charge (*1) (kg)	10.0	12.3	12.5
Design pressure			
High pressure side (bar)	40	40	40
(MPa)	4.0	4.0	4.0
Low pressure side (bar)	33	33	33
(MPa)	3.3	3.3	3.3

Model	RXYQ18PYL(E)
Power supply	
Phase	-
Frequency (Hz)	60
Voltage (V)	380
Nominal cooling capacity (kW)	49.0
Nominal heating capacity (kW)	56.5
Dimensions H×W×D (mm)	1680×1240×765
Mass (kg)	341
Refrigerant type	-
Refrigerant charge (*1) (kg)	12.7
Design pressure	
High pressure side (bar)	40
(MPa)	4.0
Low pressure side (bar)	33
(MPa)	3.3

*1:Initial refrigerant charge

[Combination unit]

RXYQ20~54PYL (*2) is the combination unit that is composed of the single units.

About the specifications see **Single unit** according to the independent unit.

*2:There is the case that RXYQ16PYL or RXYQ18PYL is composed of single unit.

2-3 What to do before Operation

This operation manual is for the following system with standard control. Before initiating operation, contact your Daikin dealer for the operation that corresponds to your system type and mark.

If your installation has a customized control system, ask your Daikin dealer for the operation that corresponds to your system.

Outdoor units (Refer to figure 1)

Cool/Heat selector	Operation modes
Inverter series	
heat pumps RXYQ series	<input type="checkbox"/> yes <input type="checkbox"/> no

• Names and functions of parts (Refer to figure 1)

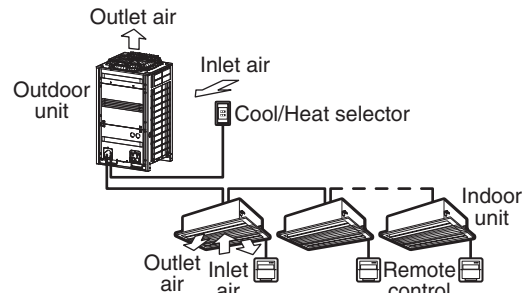

figure 1

(figure 1 shows system with Cool/Heat selector)

2-4 Remote Control and COOL/HEAT Selector: Name and Function of each Switch and Display (Refer to figure 2 and 3)

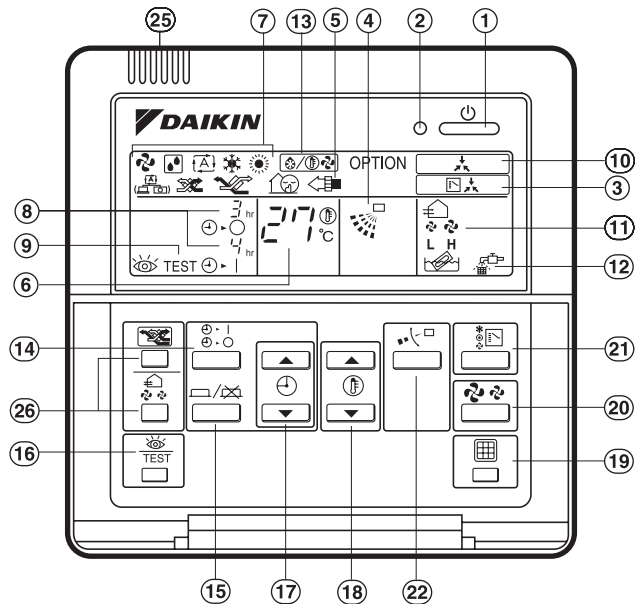

figure 2

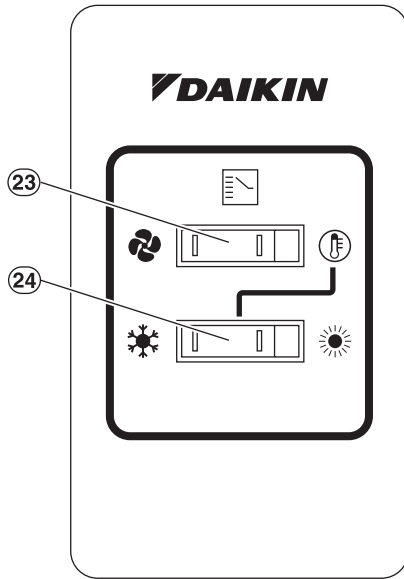

















figure 3

- 1. On/off button**
Press the button and the system will start. Press the button again and the system will stop.
- 2. Operation lamp (red)**
The lamp lights up during operation.
- 3. Display “” (changeover under control)**
It is impossible to changeover heat/cool with the remote control which display this icon.
- 4. Display “” (air flow flap)**
Refer to the chapter “Operation Procedure - Adjusting the Air Flow Direction”.
- 5. Display “ OPTION ” (ventilation/air cleaning)**
This display shows that the ventilation unit are in operation. (these are optional accessories)
- 6. Display “ ” (set temperature)**
This display shows the temperature you have set.
- 7. Display “ ” (operation mode)**
This display shows the current operation mode.
- 8. Display “ ” (programmed time)**
This display shows the programmed time of the system start or stop.
- 9. Display “ TEST ” (inspection/test operation)**
When the inspection/test operation button is pressed, the display shows the mode in which the system actually is.
- 10. Display “ ” (under centralized control)**
When this display shows, the system is under centralized control. (This is not a standard specification.)
- 11. Display “ ” (fan speed)**
This display shows the fan speed you have selected.
- 12. Display “ ” (time to clean air filter)**
Refer to the operation manual of indoor unit.
- 13. Display “ ” (defrost/hot start)**
Refer to the chapter “Operation Procedure - Explanation of Heating Operation.”
- 14. Timer mode start/stop button**
Refer to the chapter “Operation Procedure - Programming Start and Stop of the System with Timer.”
- 15. Timer on/off button**
Refer to the chapter “Operation Procedure - Programming Start and Stop of the System with Timer.”
- 16. Inspection/test operation button**
This button is only used by qualified service persons for maintenance purposes.
- 17. Programming time button**
Use this button for setting the programming start and/or stop time.
- 18. Temperature setting button**
Use this button for setting the desired temperature.

- 19. Filter sign reset button**
Refer to the operation manual of indoor unit.
- 20. Fan speed control button**
Press this button to select the fan speed of your preference.
- 21. Operation mode selector button**
Press this button to select the operation mode of your preference.
- 22. Air flow direction adjust button**
Refer to the chapter “Operation Procedure - Adjusting the Air Flow Direction”.
- 23. Fan only/air conditioning selector switch**
Set the switch to “” for fan only operation or to “” for heating or cooling operation.
- 24. Cool/heat changeover switch**
Set the switch to “” for cooling operation or to “” for heating operation.
- 25. Thermistor**
It sense the room temperature around the remote control.
- 26. These buttons are used when the ventilation unit are installed (These are optional accessories).**
Refer to the operation manual of the ventilation unit.

Note

- In contradistinction to actual operating situations, the display on figure 1 shows all possible indications.
- Figure 2 shows the remote control which is opened the cover.
- For FXS, FXM, FXL and FXN, the air flow direction adjust button (22) is not available and the display (4) shows “NOT AVAILABLE” when pressed.

2-5 Operation Range

Use the system in the following temperature and humidity ranges for safe and effective operation.

	COOLING	HEATING
outdoor temperature	-5°~43°CDB	-20°~21°CDB -20°~15.5°CWB
indoor temperature	21°~32°CDB 14°~25°CWB	15°~27°CDB
indoor humidity	≤ 80%	



Note

To avoid condensation and water dripping out the unit. If the temperature or the humidity is beyond these conditions, safety devices may work and the air conditioner may not operate.

2-6 Operation Procedure

- Operation procedure varies according to the combination of outdoor unit and remote control. Read the chapter “What to do before operation”.
- To protect the unit, turn on the main power switch 6 hours before operation.
And do not turn off the power supply during the air conditioning season because of smoothly start up.
- If the main power supply is turned off during operation, operation will restart automatically after the power turns back on again.

2-6-1 Cooling, Heating and Fan only Operation

- The operation mode cannot be changed with the remote control whose display shows “” (changeover under control).
Change the operation mode with the remote control whose display does not show “”.
- When the display “” (changeover under control) flashes, refer to the chapter “Operation Procedure - Setting the Master Remote Control”.
- The fan may keep on running for about 1 minute after the heating operation stops for removing the heat in the indoor unit.
- The air flow rate may be adjusted automatically depending on the room temperature or the fan may stop immediately. This is not a malfunction.
- For machine protection the system may control the air flow rate automatically.
- It may take sometime for finishing to change the air flow rate.
- This is normal operation.

FOR SYSTEMS WITHOUT COOL/HEAT SELECTOR (Refer to figure 4)

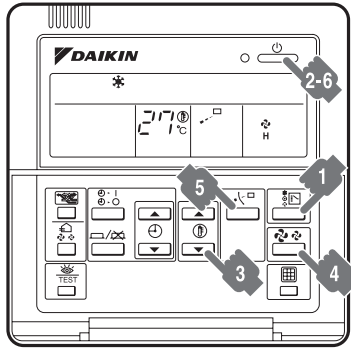

figure 4

- 1 Press the operation mode selector button several times and select the operation mode of your choice;
 - “ ❄️ ” Cooling operation
 - “ ☀️ ” Heating operation
 - “ 🌀 ” Fan only operation
- 2 Press the on/off button. The operation lamp lights up and the system starts operation.

FOR SYSTEMS WITH COOL/HEAT SELECTOR (Refer to figures 4 and 7)

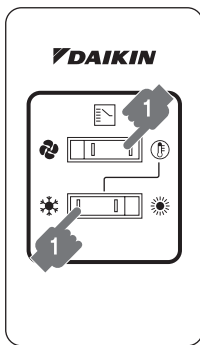

figure 7.1

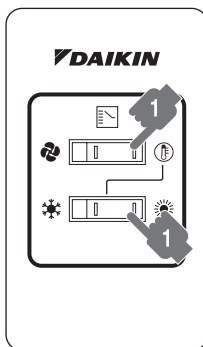

figure 7.2

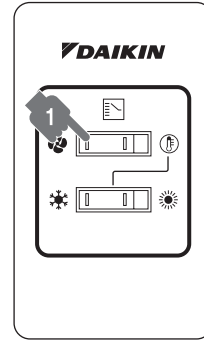

figure 7.3

- 1 Select operation mode with the Cool/Heat selector as follows:
 - “ ❄️ ” “ ❄️ ” Cooling operation (Refer to figure 7.1)
 - “ ❄️ ” “ ☀️ ” Heating operation (Refer to figure 7.2)
 - “ 🌀 ” Fan only operation (Refer to figure 7.3)
- 2 Press the on/off button. The operation lamp lights up and the system starts operation.

ADJUSTMENT (Refer to figure 4)

For adjusting the desired temperature, fan speed and air flow direction (only for FXC, FXF, FXH, FXK, FXA), follow the procedure shown below.

- 3 Press the temperature setting button and set the desired temperature.

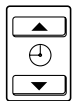

Each time this button is pressed, the temperature setting rises or lowers 1°C.

Note

- Set the temperature within the operation range.
- The temperature setting is impossible for fan only operation.

- 4 Press the fan speed control button and select the fan speed of your preference.
- 5 Press air flow direction adjust button. Refer to the chapter “Adjusting the Air Flow Direction” for details.

STOPPING THE SYSTEM (Refer to figure 4)

- 6 Press the on/off button once again. The operation lamp goes off and the system stops operation.

Note

- Do not turn off the power immediately after the unit stops.
- The system need at least 5 minutes for residual operation of drain pump device. Turning off the power immediately will cause water leak or trouble.

EXPLANATION OF HEATING OPERATION

- For general heating operation, it may take longer to reach the set temperature than in cooling operation. We recommend starting the operation which was used before using timer operation.
- The following operation is performed in order to prevent the heating capacity from dropping or cold air from blowing.

Defrost operation

- In heating operation, freezing of the outdoor unit heat exchanger increases. Heating capability decreases and the system goes into defrost operation.
- The indoor unit fan stops and the remote control displays “ ❄️/🌀 ”.
- After maximum 10 minutes of defrost operation, the system returns to heating operation again.

Hot start

- In order to prevent cold air from blowing out of an indoor unit at the start of heating operation, the indoor fan is automatically stopped. The display of the remote control shows “ ❄️/🌀 ”.

Note

- The heating capacity drops as the outside temperature falls. If this happens, use another heating device together with the unit. (When using the appliances which produce open fire together, ventilate a room constantly.) Do not place appliances which produce open fire in places exposed to the air flow from the unit or under the unit.
- It takes some time for the room to warm up from the time the unit is started since the unit uses a hot-air circulatory system to warm the entire room.
- If the hot air rises to the ceiling, leaving the area above the floor cold, we recommend using the circulator (the indoor fan for circulating air). Contact your dealer for details.

2-6-2 Program Dry Operation

- The function of this operation is to decrease the humidity in your room with a minimum temperature decrease.
- The micro computer automatically determines temperature and fan speed.
- The system does not go into operation if the room temperature is low.
- The microcomputer automatically controls the temperature and fan speed, so these cannot be set using the remote control.
- This function is not available if the room temperature is 20°C or lower.

FOR SYSTEMS WITHOUT COOL/HEAT SELECTOR (Refer to figure 5)

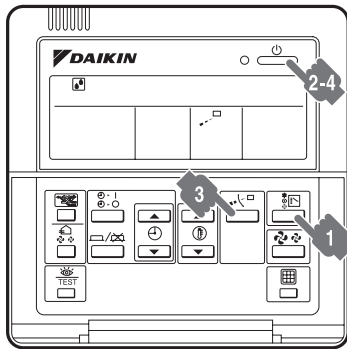

figure 5

- 1 Press the operation mode selector button several times and select “” (program dry operation).
- 2 Press the on/off button. The operation lamp lights up and the system starts operation.
- 3 Press the air flow direction adjust button (only for FXC, FXF, FXH, FXK, FXA). Refer to the chapter “Adjusting the Air Flow Direction” for details.
- 4 Press the on/off button once again. The operation lamp goes off and the system stops operation.

Note

- Do not turn off the power immediately after the unit stops.
- The system need at least 5 minutes for residual operation of drain pump device. Turning off the power immediately will cause water leak or trouble.

FOR SYSTEMS WITH COOL/HEAT SELECTOR (Refer to figure 8)

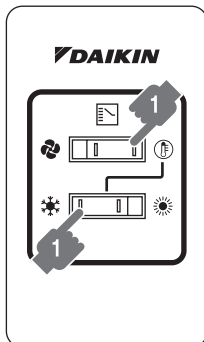

figure 8.1

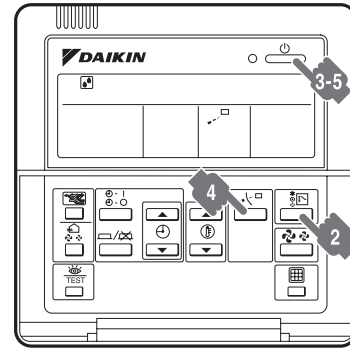

figure 8

- 1 Select cooling operation mode with the Cool/Heat selector.
- 2 Press the operation mode selector button several times and select program dry “”.
- 3 Press the on/off button. The operation lamp lights up and the system starts operation.
- 4 Press the air flow direction adjust button (only for FXC, FXF, FXH, FXK, FXA). Refer to the chapter “Adjusting the Air Flow Direction” for details.
- 5 Press the on/off button once again. The operation lamp goes off and the system stops operation.

Note

- Do not turn off the power immediately after the unit stops.
- The system need at least 5 minutes for residual operation of drain pump device. Turning off the power immediately will cause water leak or trouble.

2-6-3 Adjusting the Air Flow Direction

(Refer to figure 6) (only for FXC, FXF, FXH, FXK, FXA)

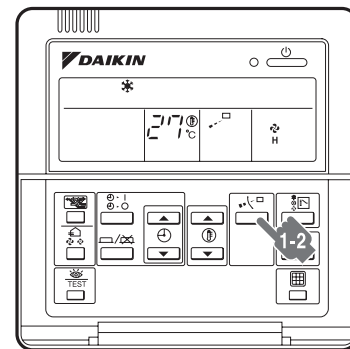

figure 6

- 1 Press the air flow direction button to select the air direction. The air flow flap display swings as shown right and the air flow direction continuously varies. (Automatic swing setting)
- 2 Press the air flow direction adjust button to select the air direction of your choice.



The air flow flap display stops swinging and the air flow direction is fixed. (Fixed air flow direction setting)

MOVEMENT OF THE AIR FLOW FLAP

For the following conditions, a micro computer controls the air flow direction which may be different from the display.

COOLING	HEATING
_____	<ul style="list-style-type: none"> • When starting operation. • When the room temperature is higher than the set temperature. • At defrost operation.
<ul style="list-style-type: none"> • When operating continuously at horizontal air flow direction. • When continuous operation with downward air flow is performed at the time of cooling with a ceiling-suspended or a wall-mounted unit, the microcomputer may control the flow direction, and then the remote control indication also will change. 	

The air flow direction can be adjusted in one of the following ways.

- The air flow flap itself adjusts its position.
- The air flow direction can be fixed by the user.

Automatic “” or desired position “”.

(Refer to figure 13)

Double-flow (FXC) + Multi-flow (FXF)

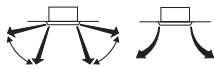

Corner (FXK)

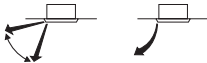

Ceiling Suspended (FXH)



Wall Mounted (FXA)

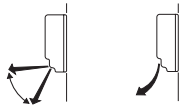

figure 13

Note

- The movable limit of the flap is changeable. Contact your Daikin dealer for details. (Only for FXC, FXF, FXH, FXK, FXA)
- Avoid operating in the horizontal direction “”. It may cause dew or dust to settle on the ceiling.

2-6-4 Programming Start and Stop of the System with Timer

(Refer to figure 9)

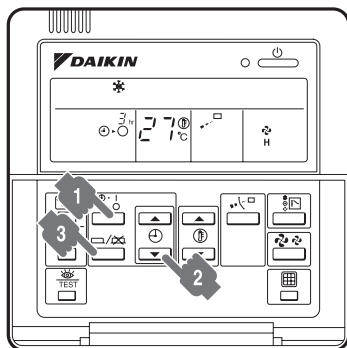
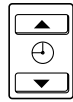

figure 9

- The timer is operated in the following two ways.
 - Programming the stop time “”. The system stops operating after the set time has elapsed.
 - Programming the start time “”. The system starts operating after the set time has elapsed.
- The timer can be programmed for a maximum of 72 hours.
- The start and the stop time can be simultaneously programmed.

- Press the timer mode start/stop button several times and select the mode on the display. The display flashes.
 - For setting the timer stop “”
 - For setting the timer start “”

- Press the programming time button and set the time for stopping or starting the system.



Each time this button is pressed, the time advances or goes backward by 1 hour.

- Press the timer on/off button. The timer setting procedure ends. The display “” or “” changes from flashing light to constant light.

Note

- When setting the timer off and on at the same time, repeat the above procedure (from “**1**” to “**3**”) once again.
- After the timer is programmed, the display shows the remaining time.
- Press the timer on/off button once again to cancel programming. The display vanishes.

For example: (Refer to figure 11)

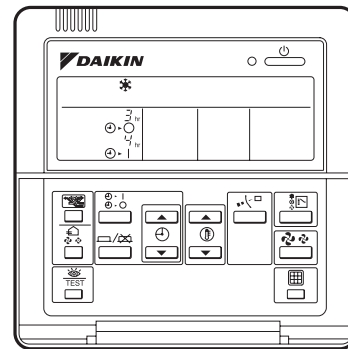

figure 11

When the timer is programmed to stop the system after 3 hours and start the system after 4 hours, the system will stop after 3 hours and start 1 hour later.

2-6-5 Setting the Master Remote Control

(Refer to figure 10)

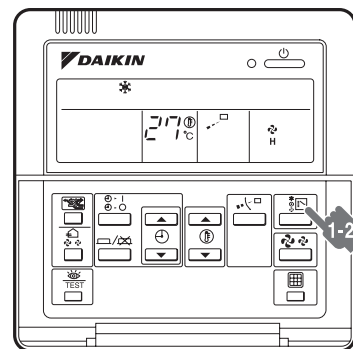

figure 10

- When one outdoor unit is connected with several indoor units as shown in figure 14, it is necessary to designate one of the remote controls as the master remote control.

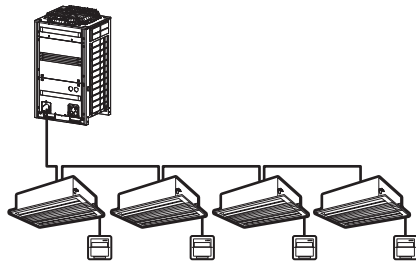

figure 14

- Only the master remote control can select heating, cooling operation.
- The displays of slave remote controls show “” (changeover under control) and they automatically follow the operation mode directed by the master remote control. However, it is possible to changeover to program dry with slave remote controls if the system is in cooling operation by setting on the master remote control and to changeover to fan only operation.

How to designate the master remote control

- Press the operation mode selector button of the current master remote control for 4 seconds.
The display showing “” (changeover under control) of all slave remote controls connected to the same outdoor unit flashes.
- Press the operation mode selector button of the controller that you wish to designate as the master remote control. Then designation is completed. This remote control is designated as the master remote control and the display showing “” (changeover under control) vanishes.
The displays of other remote controls show “” (changeover under control).

2-6-6 Precautions for Group Control System or Two Remote Control Control System

This system provides two other control systems beside individual control (one remote control controls one indoor unit) system. Confirm about your system to Daikin dealer.

- Group control system**
One remote control controls up to 16 indoor units. All indoor units are equally set.
- Two remote control control system**
Two remote controls control one indoor unit (in case of group control system, one group of indoor units). The unit is individually operated.

Note

- Contact your Daikin dealer in case of changing the combination or setting of group control and two remote control control systems.

2-7 Optimum Operation

Observe the following precautions to ensure the system operates properly.

- Adjust the air outlet properly and avoid direct air flow to room inhabitants.
- Adjust the room temperature properly for a comfortable environment. Avoid excessive heating or cooling.
- Prevent direct sunlight from entering a room during cooling operation by using curtains or blinds.
- Ventilate often.
Extended use requires special attention to ventilation.
- Do not keep doors and windows opened. If the doors and windows remain open, air will flow out of your room causing a decrease in the cooling or heating effect.
- Never place objects near the air inlet or the air outlet of the unit. It may cause deterioration in the effect or stop the operation.

- Turn off the main power supply switch to the unit when the unit is not used for longer periods of time. If the switch is on, it uses electricity. Before restarting the unit, turn on the main power supply switch 6 hours before operation to ensure smooth running. (Refer to the chapter “Maintenance” in the indoor unit manual.)
- When the display shows “” (time to clean the air filter), ask a qualified service person to clean the filters. (Refer to the chapter “Maintenance” in the indoor unit manual.)
- Keep the indoor unit and remote control at least 1 m away from televisions, radios, stereos, and other similar equipment. Failing to do so may cause static or distorted pictures.
- Do not use other heating devices directly beneath the indoor unit. If you do, they might get deformed by the heat.

2-8 Seasonal Maintenance

2-8-1 At the Beginning of the Season

Check

- Are the indoor and outdoor unit intake and outlet vents blocked? Remove anything that might be blocking them.

Clean the air filter and exterior.

- After cleaning the air filter, be sure to put it back in the same position. See the operation manual included with the indoor unit for details on how to clean it.

Turn the power on.

- When the power comes on, the characters in the remote control display appear. (To protect the unit, turn the power on at least 6 hours before operating it. This makes operation smoother.)

2-8-2 At the End of the Season

On a clear day, use fan operation for around half a day to thoroughly dry out the interior of the unit.

- Refer to page 4 for details on fan operation.

Turn off the power

- When the power is shut off, the characters in the remote control display disappear.
- When the power is on, the unit consumes up to several dozen Watts of power. Turn off the power to conserve energy.

Clean the air filter and exterior.

- After cleaning the air filter, be sure to put it back in the same position. See the operation manual included with the indoor unit for details on how to clean it.

2-9 Following Symptoms are not Air Conditioner Troubles

2-9-1 The System does not Operate

- The air conditioner does not start immediately when restart the operation after stop the operation or change operation mode after set the operation mode.**
If the operation lamp lights, the system is in normal condition. To prevent overloading of the compressor motor, the air conditioner starts 5 minutes after it is turned ON again in case it was turned OFF just before.
- If “” (under centralized control) is displayed on the remote control and pressing the operation button causes the display to blink for a few seconds.**
This indicates that the central device is controlling the unit. The blinking display indicates that the remote control cannot be used.
- The system does not start immediately after the power supply is turned on.**
Wait one minute until the micro computer is prepared for operation.

2-9-2 It Stops sometimes

- The remote control display reads “U4” or “U5” and stops but then restarts after a few minutes.**
This is because the remote control is intercepting noise from electrical appliances other than the air conditioner, and this prevents communication between the units, causing them to stop. Operation automatically restarts when the noise goes away.

2-9-3 COOL/HEAT cannot be Changed Over

- When the display shows “  ” (changeover under control).

It shows that this is a slave remote control. Refer to “Setting the Master Remote Control”.

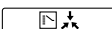
- When the cool/heat selector switch is installed and the display shows “  ” (changeover under control).

This is because cool/heat changeover is controlled by the cool/heat selector. Ask your Daikin dealer where the remote control switch is installed.

2-9-4 Fan Operation is Possible, but Cooling and Heating do not Work

- Immediately after the power is turned on.
The micro computer is getting ready to operate. Wait 10 minutes.

2-9-5 The Fan Strength does not Correspond to the Setting

- The fan strength does not change even if the fan strength adjustment button is pressed.

During heating operation, when the room temperature reaches the set temperature, the outdoor unit goes off and the indoor unit changes to whisper fan strength.

This is to prevent cold air blowing directly on occupants of the room.

The fan strength will not change even if the button is changed, when another indoor unit is in heating operation.

2-9-6 The Fan Direction does not Correspond to the Setting

- The fan direction does not correspond to the remote control display.

The fan direction does not swing.

This is because the unit is being controlled by the micro computer. Refer to “Adjusting the Air Flow Direction”.

2-9-7 White Mist Comes Out of a Unit

Indoor unit

- When humidity is high during cooling operation.
If the interior of an indoor unit is extremely contaminated, the temperature distribution inside a room becomes uneven. It is necessary to clean the interior of the indoor unit. Ask your Daikin dealer for details on cleaning the unit. This operation requires a qualified service person.
- Immediately after the cooling operation stops and if the room temperature and humidity are low.
This is because warm refrigerant gas flows back into the indoor unit and generates steam.

Indoor unit, outdoor unit

- When the system is changed over to heating operation after defrost operation.
Moisture generated by defrost becomes steam and is exhausted.

2-9-8 Noise of Air Conditioners

Indoor unit

- A “zeen” sound is heard immediately after the power supply is turned on.
The electronic expansion valve inside an indoor unit starts working and makes the noise. Its volume will reduce in about one minute.
- A continuous low “shah” sound is heard when the system is in cooling operation or at a stop.
When the drain pump (optional accessories) is in operation, this noise is heard.
- A “pishi-pishi” squeaking sound is heard when the system stops after heating operation.
Expansion and contraction of plastic parts caused by temperature change make this noise.
- A low “sah”, “choro-choro” sound is heard while the indoor unit is stopped.
When the other indoor unit is in operation, this noise is heard. In order to prevent oil and refrigerant from remaining in the system, a small amount of refrigerant is kept flowing.

Outdoor unit

- When the tone of operating noise changes.
This noise is caused by the change of frequency.

Indoor unit, outdoor unit

- A continuous low hissing sound is heard when the system is in cooling or defrost operation.
This is the sound of refrigerant gas flowing through both indoor and outdoor units.
- A hissing sound which is heard at the start or immediately after stopping operation or defrost operation.
This is the noise of refrigerant caused by flow stop or flow change.

2-9-9 Dust Comes Out of the Unit

- When the unit is used after stopping for a long time.
This is because dust has gotten into the unit.

2-9-10 The Units can Give off Odours

- During operation.
The unit can absorb the smell of rooms, furniture, cigarettes, etc., and then emit it again.

2-9-11 The Outdoor Unit Fan does not Spin

- During operation.
The speed of the fan is controlled in order to optimize product operation.

2-9-12 The Display Shows “ 00 ”

- This is the case immediately after the main power supply switch is turned on.
This means that the remote control is in normal condition. This continues for one minute.

2-9-13 The Compressor or Fan in the Outdoor Unit does not Stop

- This is to prevent oil and refrigerant from remaining in the compressor. The unit will stop after 5 to 10 minutes.

2-9-14 The Inside of an Outdoor Unit is Warm even when the Unit has Stopped

- This is because the crankcase heater is warming the compressor so that the compressor can start smoothly.

2-9-15 It Stops Sometimes

- The remote control display reads “U4” and “U5” and stops but then restarts after a few minutes.
This is because the remote control is intercepting noise from electrical appliances other than the air conditioner, and this prevents communication between the units, causing them to stop. Operation automatically restarts when the noise goes away.

2-9-16 Hot Air is Emitted even though the Unit is Stopped

- Hot air can be felt when the unit is stopped.
Several different indoor units are being run on the same system, so if another unit is running, some refrigerant will still flow through the unit.

2-9-17 Does not Cool very well

- Program dry operation.
Program dry operation is designed to lower the room temperature as little as possible. Refer to page 326.

2-10 Trouble Shooting

If one of the following malfunctions occur, take the measures shown below and contact your Daikin dealer.

Warning

Stop operation and shut off the power if anything unusual occurs (burning smells, etc.)

Leaving the unit running under such circumstances may cause breakage, electrical shock, or fire. Contact your dealer.

- If a safety device such as a fuse, a breaker or an earth leakage breaker frequently actuates;
Measure : Do not turn on the main power switch.
- If the ON/OFF switch does not properly work;
Measure: Turn off the main power switch.
- If water leaks from unit;
Measure: Stop the operation.
- The operation switch does not work well.
Turn off the power.
- If the display “ TEST”, the unit number and the operation lamp flash and the malfunction code appears; (Refer to figure 12)

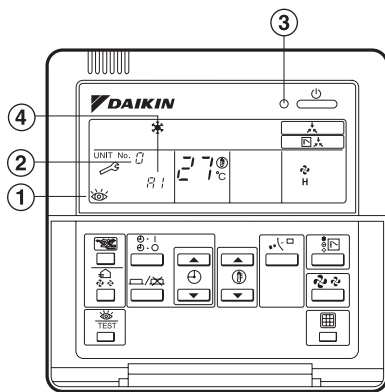

figure 12

1. Inspection display
2. Indoor unit number in which a malfunction occurs
3. Operation lamp
4. Malfunction code

Measure: Notify your Daikin dealer and report the malfunction code.

If the system does not properly operate except for the above mentioned cases and none of the above mentioned malfunctions is evident, investigate the system according to the following procedures.

If it is impossible to fix the problem yourself after checking all the above items, contact your dealer.

Let him know the symptoms, system name, and model name (listed on the warranty card).

1. If the system does not operate at all;
 - Check if there is no power failure.
Wait until power is restored. If power failure occurs during operation, the system automatically restarts immediately after the power supply is recovered.
 - Check if no fuse has blown;
Turn off the power supply
 - Check if the breaker is blown.
Turn the power on with the breaker switch in the off position.
Do not turn the power on with the breaker switch in the trip position.
(Contact your dealer.)

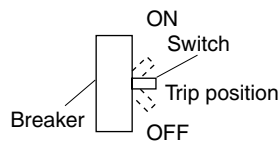

2. If the system stops soon after starting the operation;
 - Check if air inlet or outlet of outdoor or indoor unit is not blocked by obstacles.
Remove any obstacle and make it well-ventilated.
 - Check if the remote control display shows “” (time to clean the air filter);
Refer to the operation manual of the indoor unit. And clean the air filter.

3. The system operates but cooling or heating is insufficient;
 - Check if air inlet or outlet of outdoor or indoor unit is not blocked by obstacles.
Remove any obstacle and make it well-ventilated.
 - Check if the remote control display shows “” (time to clean the air filter);
Refer to the operation manual of the indoor unit. And clean the air filter.
 - Check the temperature setting.
Refer to “Operation Procedure”.
 - Check the fan speed setting on your remote control.
Refer to “Operation Procedure”.
 - Check for open doors or windows.
Shut doors and windows to prevent wind from coming in.
 - Check if there are too many occupants in the room during cooling operation.
 - Check if the heat source of the room is excessive during cooling operation.
 - Check if direct sunlight enters the room during cooling operation.
Use curtains or blinds.
 - Check if the air flow angle is not proper.
Refer to “Operation Procedure”.

After-sales service and warranty

After-sales service:

Warning

- **Do not modify the unit.**
This may cause electric shock or fire.
- **Do not disassemble or repair the unit.**
This may cause electric shock or fire.
Contact your dealer.
- **If the refrigerant leaks, keep out of fire.**
Although the refrigerant does not usually leak, if the refrigerant leaks out into a room and comes in contact with the combustible air in the equipment such as fan heater, stove, oil (gas) cooker, etc., it will cause toxic gas to be generated.
When a refrigerant leakage failure has been repaired, confirm a service person that the leakage point has been corrected surely before restarting operation.
- **Do not remove or reinstall the unit by yourself.**
Incorrect installation may cause electrical shock or fire.
Contact your dealer.

When asking your dealer to repair, inform related staff of the details as follows:

- Product No. of air conditioner:
Refer to the warranty card.
- Shipping date and installation date:
Refer to the warranty card.
- Malfunction:
Inform the staff of the defective details.
(Malfunction code being displayed on the remote control.)
- Name, address, telephone number
- **Repair where the warranty term is expired**
Contact your dealer. If necessary to repair, pay service is available.
- **Minimum storage period of important parts**
Even after a certain type of air conditioner is discontinued, we have the related important parts in stock for 9 years at least. The important parts indicate parts essential to operate the air conditioner.
- **Recommendations for maintenance and inspection**
Since dust collects after using the unit for several years, the performance will be deteriorated to some extent. Taking apart and cleaning inside require technical expertise, so we recommend entering a maintenance and inspection contract (at a cost) separate from normal maintenance.
- **Recommended inspection and maintenance cycles**
[Note: The maintenance cycle is not the same as the warranty period.]

Table 1 assumes the following usage conditions.

1. Normal use without frequent starting and stopping of the machine.
(Although it varies with the model, we recommend not starting and stopping the machine more than 6 times/hour for normal use.)
2. Operation of the product is assumed to be 10 hours/day, 2500 hours/year.

• Table 1 "Inspection Cycle" and "Maintenance Cycle" Lists

Name of Main Part	Inspection Cycle	Maintenance Cycle [replacements and/or repairs]
Electric motor (fan, damper, etc.)	1 year	20,000 hours
PC boards		25,000 hours
Heat exchanger		5 years
Sensor (thermistors, etc.)		5 years
Remote Control and switches		25,000 hours
Drain pan		8 years
Expansion valve		20,000 hours
Electromagnetic valve		20,000 hours

Note 1

This table indicates main parts.
See the maintenance and inspection contract for details.

Note 2

This maintenance cycle indicates recommended lengths of time until the need arises for maintenance work, in order to ensure the product is operational as long as possible.
Use for appropriate maintenance design (budgeting maintenance and inspection fees, etc.)
Depending on the content of the maintenance and inspection contract, the inspection and maintenance cycles may in reality be shorter than those listed here.

Shortening of "maintenance cycle" and "replacement cycle" needs to be considered in the following cases.

1. When used in hot, humid locations or locations where temperature and humidity fluctuate greatly.
2. When used in locations where power fluctuation (voltage, frequency, wave distortion, etc.) is high.
(Cannot be used if it is outside the allowable range.)
3. When installed and used in locations where bumps and vibrations are frequent.
4. When used in bad locations where dust, salt, harmful gas or oil mist such as sulfurous acid and hydrogen sulfide may be present in the air.
5. When used in locations where the machine is started and stopped frequently or operation time is long. (Example: 24 hour air-conditioning)

■ Recommended replacement cycle of wear-out parts [The cycle is not the same as the warranty period.]

• Table 2 "Replacement Cycle" Lists

Name of Main Part	Inspection Cycle	Replacement Cycle
Air filter	1 year	5 years
High efficiency filter (Optional accessory)		1 year
Fuse		10 years
Crankcase heater		8 years

Note 1

This table indicates main parts.
See the maintenance and inspection contract for details.

Note 2

This maintenance cycle indicates recommended lengths of time until the need arises for maintenance work, in order to ensure the product is operational as long as possible.
Use for appropriate maintenance design (budgeting maintenance and inspection fees, etc.).

Contact your dealer for details.

Note: Breakage due to taking apart or cleaning inside by anyone other than our authorized dealers may not be included in the warranty.

■ Moving and discarding the unit

- Contact your dealer for removing and reinstalling the system air conditioner since they require technical expertise.
- The system air conditioner uses fluorocarbon refrigerant. Contact your dealer for discarding the system air conditioner since it is required by law to collect, transport and discard the refrigerant in accordance with relevant local and national regulations.

■ Where to call

For after-sales service, etc., consult with your dealer.

■ Warranty period:

- This product includes a warranty card.
The warranty card is given to a customer after dealer staff fills out necessary items in the card. The customer should check the entered items and store it carefully.
Warranty period: Within one year after installation.
For further details, refer to the warranty card.
- If it is necessary to repair the air conditioner within the warranty period, contact your dealer and show your warranty card. If the warranty card is not shown, pay-service repair may be performed even though the warranty period is not expired.

Part 4

Precautions for New Refrigerant (R-410A)

1. Precautions for New Refrigerant (R-410A)	334
1.1 Outline	334
1.2 Refrigerant Cylinders.....	336
1.3 Service Tools.....	337

1. Precautions for New Refrigerant (R-410A)

1.1 Outline

1.1.1 About Refrigerant R-410A

- Characteristics of new refrigerant, R-410A
 1. Performance
Almost the same performance as R-22 and R-407C
 2. Pressure
Working pressure is approx. 1.4 times more than R-22 and R-407C.
 3. Refrigerant composition
Few problems in composition control, since it is a Quasi-azeotropic mixture refrigerant.

	HFC units (Units using new refrigerants)		HCFC units
Refrigerant name	R-407C	R-410A	R-22
Composing substances	Non-azeotropic mixture of HFC32, HFC125 and HFC134a (*1)	Quasi-azeotropic mixture of HFC32 and JFC125 (*1)	Single-component refrigerant
Design pressure	3.2 MPa (gauge pressure) = 32.6 kgf/cm ²	4.0 MPa (gauge pressure) = 40.8 kgf/cm ²	2.75MPa (gauge pressure) = 28.0 kgf/cm ²
Refrigerant oil	Synthetic oil (Ether)		Mineral oil (Suniso)
Ozone destruction factor (ODP)	0	0	0.05
Combustibility	None	None	None
Toxicity	None	None	None

- ★1. Non-azeotropic mixture refrigerant: mixture of two or more refrigerants having different boiling points.
- ★2. Quasi-azeotropic mixture refrigerant: mixture of two or more refrigerants having similar boiling points.
- ★3. The design pressure is different at each product. Please refer to the installation manual for each product.
(Reference) 1 MPa ≒ 10.19716 kgf / cm²

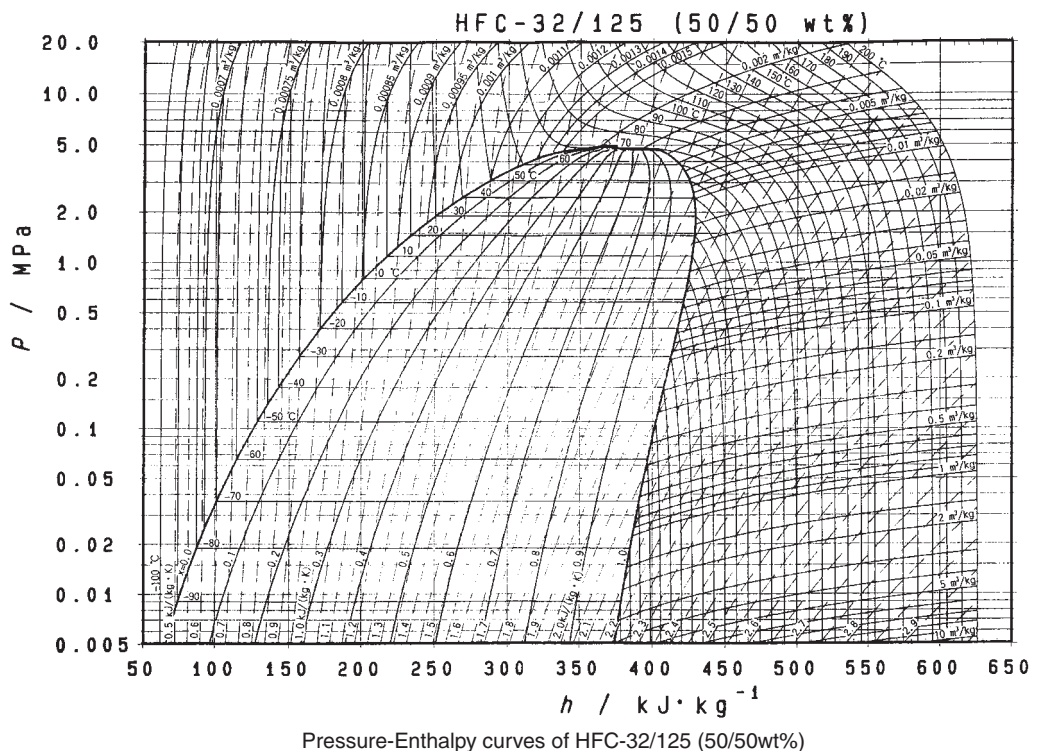

■ Thermodynamic characteristic of R-410A

DAIREP ver2.0

Temperature (°C)	Steam pressure (kPa)		Density (kg/m ³)		Specific heat at constant pressure (kJ/kgK)		Specific enthalpy (kJ/kg)		Specific entropy (kJ/KgK)	
	Liquid	Vapor	Liquid	Vapor	Liquid	Vapor	Liquid	Vapor	Liquid	Vapor
-70	36.13	36.11	1410.7	1.582	1.372	0.695	100.8	390.6	0.649	2.074
-68	40.83	40.80	1404.7	1.774	1.374	0.700	103.6	391.8	0.663	2.066
-66	46.02	45.98	1398.6	1.984	1.375	0.705	106.3	393.0	0.676	2.058
-64	51.73	51.68	1392.5	2.213	1.377	0.710	109.1	394.1	0.689	2.051
-62	58.00	57.94	1386.4	2.463	1.378	0.715	111.9	395.3	0.702	2.044
-60	64.87	64.80	1380.2	2.734	1.379	0.720	114.6	396.4	0.715	2.037
-58	72.38	72.29	1374.0	3.030	1.380	0.726	117.4	397.6	0.728	2.030
-56	80.57	80.46	1367.8	3.350	1.382	0.732	120.1	398.7	0.741	2.023
-54	89.49	89.36	1361.6	3.696	1.384	0.737	122.9	399.8	0.754	2.017
-52	99.18	99.03	1355.3	4.071	1.386	0.744	125.7	400.9	0.766	2.010
-51.58	101.32	101.17	1354.0	4.153	1.386	0.745	126.3	401.1	0.769	2.009
-50	109.69	109.51	1349.0	4.474	1.388	0.750	128.5	402.0	0.779	2.004
-48	121.07	120.85	1342.7	4.909	1.391	0.756	131.2	403.1	0.791	1.998
-46	133.36	133.11	1336.3	5.377	1.394	0.763	134.0	404.1	0.803	1.992
-44	146.61	146.32	1330.0	5.880	1.397	0.770	136.8	405.2	0.816	1.987
-42	160.89	160.55	1323.5	6.419	1.401	0.777	139.6	406.2	0.828	1.981
-40	176.24	175.85	1317.0	6.996	1.405	0.785	142.4	407.3	0.840	1.976
-38	192.71	192.27	1310.5	7.614	1.409	0.792	145.3	408.3	0.852	1.970
-36	210.37	209.86	1304.0	8.275	1.414	0.800	148.1	409.3	0.864	1.965
-34	229.26	228.69	1297.3	8.980	1.419	0.809	150.9	410.2	0.875	1.960
-32	249.46	248.81	1290.6	9.732	1.424	0.817	153.8	411.2	0.887	1.955
-30	271.01	270.28	1283.9	10.53	1.430	0.826	156.6	412.1	0.899	1.950
-28	293.99	293.16	1277.1	11.39	1.436	0.835	159.5	413.1	0.911	1.946
-26	318.44	317.52	1270.2	12.29	1.442	0.844	162.4	414.0	0.922	1.941
-24	344.44	343.41	1263.3	13.26	1.448	0.854	165.3	414.9	0.934	1.936
-22	372.05	370.90	1256.3	14.28	1.455	0.864	168.2	415.7	0.945	1.932
-20	401.34	400.06	1249.2	15.37	1.461	0.875	171.1	416.6	0.957	1.927
-18	432.36	430.95	1242.0	16.52	1.468	0.886	174.1	417.4	0.968	1.923
-16	465.20	463.64	1234.8	17.74	1.476	0.897	177.0	418.2	0.980	1.919
-14	499.91	498.20	1227.5	19.04	1.483	0.909	180.0	419.0	0.991	1.914
-12	536.58	534.69	1220.0	20.41	1.491	0.921	182.9	419.8	1.003	1.910
-10	575.26	573.20	1212.5	21.86	1.499	0.933	185.9	420.5	1.014	1.906
-8	616.03	613.78	1204.9	23.39	1.507	0.947	189.0	421.2	1.025	1.902
-6	658.97	656.52	1197.2	25.01	1.516	0.960	192.0	421.9	1.036	1.898
-4	704.15	701.49	1189.4	26.72	1.524	0.975	195.0	422.6	1.048	1.894
-2	751.64	748.76	1181.4	28.53	1.533	0.990	198.1	423.2	1.059	1.890
0	801.52	798.41	1173.4	30.44	1.543	1.005	201.2	423.8	1.070	1.886
2	853.87	850.52	1165.3	32.46	1.552	1.022	204.3	424.4	1.081	1.882
4	908.77	905.16	1157.0	34.59	1.563	1.039	207.4	424.9	1.092	1.878
6	966.29	962.42	1148.6	36.83	1.573	1.057	210.5	425.5	1.103	1.874
8	1026.5	1022.4	1140.0	39.21	1.584	1.076	213.7	425.9	1.114	1.870
10	1089.5	1085.1	1131.3	41.71	1.596	1.096	216.8	426.4	1.125	1.866
12	1155.4	1150.7	1122.5	44.35	1.608	1.117	220.0	426.8	1.136	1.862
14	1224.3	1219.2	1113.5	47.14	1.621	1.139	223.2	427.2	1.147	1.859
16	1296.2	1290.8	1104.4	50.09	1.635	1.163	226.5	427.5	1.158	1.855
18	1371.2	1365.5	1095.1	53.20	1.650	1.188	229.7	427.8	1.169	1.851
20	1449.4	1443.4	1085.6	56.48	1.666	1.215	233.0	428.1	1.180	1.847
22	1530.9	1524.6	1075.9	59.96	1.683	1.243	236.4	428.3	1.191	1.843
24	1615.8	1609.2	1066.0	63.63	1.701	1.273	239.7	428.4	1.202	1.839
26	1704.2	1697.2	1055.9	67.51	1.721	1.306	243.1	428.6	1.214	1.834
28	1796.2	1788.9	1045.5	71.62	1.743	1.341	246.5	428.6	1.225	1.830
30	1891.9	1884.2	1034.9	75.97	1.767	1.379	249.9	428.6	1.236	1.826
32	1991.3	1983.2	1024.1	80.58	1.793	1.420	253.4	428.6	1.247	1.822
34	2094.5	2086.2	1012.9	85.48	1.822	1.465	256.9	428.4	1.258	1.817
36	2201.7	2193.1	1001.4	90.68	1.855	1.514	260.5	428.3	1.269	1.813
38	2313.0	2304.0	989.5	96.22	1.891	1.569	264.1	428.0	1.281	1.808
40	2428.4	2419.2	977.3	102.1	1.932	1.629	267.8	427.7	1.292	1.803
42	2548.1	2538.6	964.6	108.4	1.979	1.696	271.5	427.2	1.303	1.798
44	2672.2	2662.4	951.4	115.2	2.033	1.771	275.3	426.7	1.315	1.793
46	2800.7	2790.7	937.7	122.4	2.095	1.857	279.2	426.1	1.327	1.788
48	2933.7	2923.6	923.3	130.2	2.168	1.955	283.2	425.4	1.339	1.782
50	3071.5	3061.2	908.2	138.6	2.256	2.069	287.3	424.5	1.351	1.776
52	3214.0	3203.6	892.2	147.7	2.362	2.203	291.5	423.5	1.363	1.770
54	3361.4	3351.0	875.1	157.6	2.493	2.363	295.8	422.4	1.376	1.764
56	3513.8	3503.5	856.8	168.4	2.661	2.557	300.3	421.0	1.389	1.757
58	3671.3	3661.2	836.9	180.4	2.883	2.799	305.0	419.4	1.403	1.749
60	3834.1	3824.2	814.9	193.7	3.191	3.106	310.0	417.6	1.417	1.741
62	4002.1	3992.7	790.1	208.6	3.650	3.511	315.3	415.5	1.433	1.732
64	4175.7	4166.8	761.0	225.6	4.415	4.064	321.2	413.0	1.450	1.722

1.2 Refrigerant Cylinders

- Cylinder specifications
 - The cylinder is painted refrigerant color (pink).
 - The cylinder valve is equipped with a siphon tube.

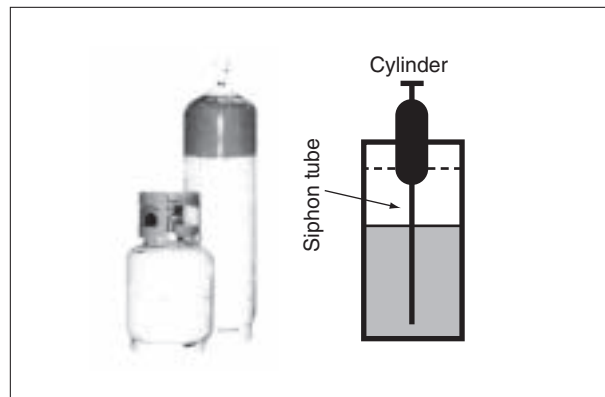

Refrigerant can be charged in liquid state with cylinder in upright position.

Caution: Do not lay cylinder on its side during charging, since it cause refrigerant in gas state to enter the system.

- Handling of cylinders
 - (1) Laws and regulations

R-410A is liquefied gas, and the High-Pressure Gas Safety Law must be observed in handling them. Before using, refer to the High-Pressure Gas Safety Law.
The Law stipulates standards and regulations that must be followed to prevent accidents with high-pressure gases. Be sure to follow the regulations.
 - (2) Handling of vessels

Since R-410A is high-pressure gas, it is contained in high-pressure vessels. Although those vessels are durable and strong, careless handling can cause damage that can lead to unexpected accidents. Do not drop vessels, let them fall, apply impact or roll them on the ground.
 - (3) Storage

Although R-410A is not flammable, it must be stored in a well-ventilated, cool, and dark place in the same way as any other high-pressure gases.
It should also be noted that high-pressure vessels are equipped with safety devices that releases gas when the ambient temperature reaches more than a certain level (fusible plug melts) and when the pressure exceeds a certain level (spring-type safety valve operates).

1.3 Service Tools

R-410A is used under higher working pressure, compared to previous refrigerants (R-22,R-407C). Furthermore, the refrigerating machine oil has been changed from Suniso oil to Ether oil, and if oil mixing is occurred, sludge results in the refrigerants and causes other problems. Therefore, gauge manifolds and charge hoses that are used with a previous refrigerant (R-22,R-407C) can not be used for products that use new refrigerants.

Be sure to use dedicated tools and devices.

■ Tool compatibility

Tool	Compatibility			Reasons for change
	HFC		HCFC	
	R-410A	R-407C	R-22	
Gauge manifold Charge hose	×			<ul style="list-style-type: none"> Do not use the same tools for R-22 and R-410A. Thread specification differs for R-410A and R-407C.
Charging cylinder	×		○	<ul style="list-style-type: none"> Weighting instrument used for HFCs.
Gas detector	○		×	<ul style="list-style-type: none"> The same tool can be used for HFCs.
Vacuum pump (pump with reverse flow preventive function)		○		<ul style="list-style-type: none"> To use existing pump for HFCs, vacuum pump adapter must be installed.
Weighting instrument		○		
Charge mouthpiece		×		<ul style="list-style-type: none"> Seal material is different between R-22 and HFCs. Thread specification is different between R-410A and others.
Flaring tool (Clutch type)		○		<ul style="list-style-type: none"> For R-410A, flare gauge is necessary.
Torque wrench		○		<ul style="list-style-type: none"> Torque-up for 1/2 and 5/8
Pipe cutter		○		
Pipe expander		○		
Pipe bender		○		
Pipe assembling oil		×		<ul style="list-style-type: none"> Due to refrigerating machine oil change. (No Suniso oil can be used.)
Refrigerant recovery device	Check your recovery device.			
Refrigerant piping	See the chart below.			<ul style="list-style-type: none"> Only $\phi 19.1$ is changed to 1/2H material while the previous material is "O".

As for the charge mouthpiece and packing, 1/2UNF20 is necessary for mouthpiece size of charge hose.

■ Copper tube material and thickness

Pipe size	Ve-up R-407C		Ve-up II R-410A	
	Material	Thickness t (mm)	Material	Thickness t (mm)
	$\phi 6.4$	○	0.8	○
$\phi 9.5$	○	0.8	○	0.8
$\phi 12.7$	○	0.8	○	0.8
$\phi 15.9$	○	1.0	○	1.0
$\phi 19.1$	○	1.0	1/2H	1.0
$\phi 22.2$	1/2H	1.0	1/2H	1.0
$\phi 25.4$	1/2H	1.0	1/2H	1.0
$\phi 28.6$	1/2H	1.0	1/2H	1.0
$\phi 31.8$	1/2H	1.2	1/2H	1.1
$\phi 38.1$	1/2H	1.4	1/2H	1.4
$\phi 44.5$	1/2H	1.6	1/2H	1.6

* O: Soft (Annealed)

H: Hard (Drawn)

1. Flaring tool



Flare gauge

- Specifications
- Dimension A

Unit:mm

Nominal size	Tube O.D. Do	A ⁺⁰ _{-0.4}	
		Class-2 (R-410A)	Class-1 (Conventional)
1/4	6.35	9.1	9.0
3/8	9.52	13.2	13.0
1/2	12.70	16.6	16.2
5/8	15.88	19.7	19.4
3/4	19.05	24.0	23.3

- Differences
- Change of dimension A

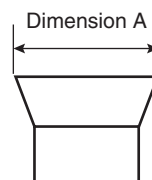

For class-1: R-407C
For class-2: R-410A

Conventional flaring tools can be used when the work process is changed.
(change of work process)

Previously, a pipe extension margin of 0 to 0.5mm was provided for flaring. For R-410A air conditioners, perform pipe flaring with a pipe extension margin of 1.0 to 1.5mm.

(For clutch type only)

Conventional tool with pipe extension margin adjustment can be used.

2. Torque wrench



■ Specifications

- Dimension B Unit:mm

Nominal size	Class-1	Class-2	Previous
1/2	24	26	24
5/8	27	29	27

No change in tightening torque

No change in pipes of other sizes

■ Differences

- Change of dimension B
Only 1/2", 5/8" are extended

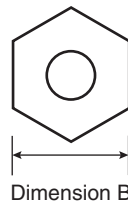

For class-1: R-407C
For class-2: R-410A

3. Vacuum pump with check valve

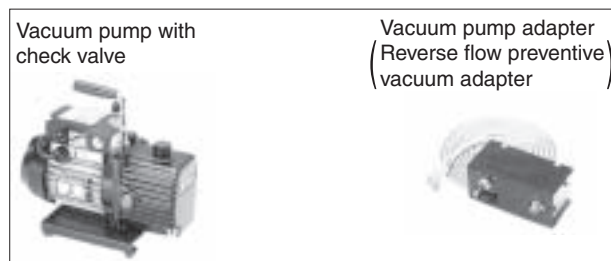

■ Specifications

- Discharge speed
50 l/min (50Hz)
60 l/min (60Hz)
- Suction port UNF7/16-20(1/4 Flare)
UNF1/2-20(5/16 Flare) with adapter
- Maximum degree of vacuum
Select a vacuum pump which is able to keep the vacuum degree of the system in excess of -100.7 kPa (5 torr – 755 mmHg).

■ Differences

- Equipped with function to prevent reverse oil flow
- Previous vacuum pump can be used by installing adapter.

4. Leak tester



- Specifications
 - Hydrogen detecting type, etc.
 - Applicable refrigerants
R-410A, R-407C, R-404A, R-507A, R-134a, etc.
- Differences
 - Previous testers detected chlorine. Since HFCs do not contain chlorine, new tester detects hydrogen.

5. Refrigerant oil (Air compal)



- Specifications
 - Contains synthetic oil, therefore it can be used for piping work of every refrigerant cycle.
 - Offers high rust resistance and stability over long period of time.
- Differences
 - Can be used for R-410A and R-22 units.

6. Gauge manifold for R-410A



- Specifications
 - High pressure gauge
- 0.1 to 5.3 MPa (-76 cmHg to 53 kg/cm²)
 - Low pressure gauge
- 0.1 to 3.8 MPa (-76 cmHg to 38 kg/cm²)
 - 1/4" → 5/16" (2min → 2.5min)
 - No oil is used in pressure test of gauges.
→ For prevention of contamination

- Temperature scale indicates the relationship between pressure and temperature in gas saturated state.
- Differences
 - Change in pressure
 - Change in service port diameter

7. Charge hose for R-410A

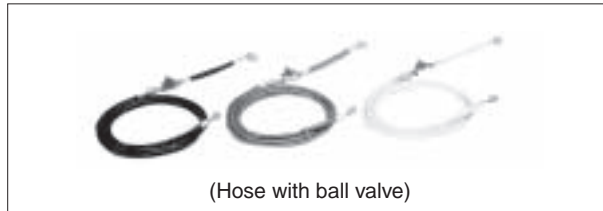

- Specifications
 - Working pressure 5.08 MPa (51.8 kg/cm²)
 - Rupture pressure 25.4 MPa (259 kg/cm²)
 - Available with and without hand-operate valve that prevents refrigerant from outflow.
- Differences
 - Pressure proof hose
 - Change in service port diameter
 - Use of nylon coated material for HFC resistance

8. Charging cylinder

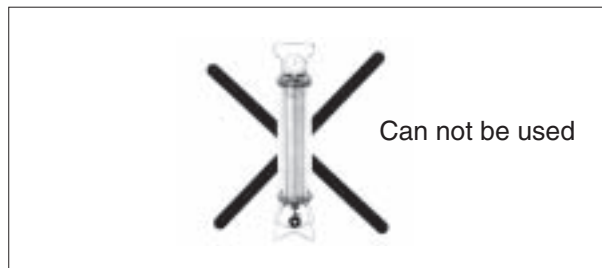

- Specifications
 - Use weigher for refrigerant charge listed below to charge directly from refrigerant cylinder.
- Differences
 - The cylinder can not be used for mixed refrigerant since mixing ratio is changed during charging.

When R-410A is charged in liquid state using charging cylinder, foaming phenomenon is generated inside charging cylinder.

9. Weigher for refrigerant charge



- Specifications
 - High accuracy
 - TA101A (for 10-kg cylinder) = $\pm 2\text{g}$
 - TA101B (for 20-kg cylinder) = $\pm 5\text{g}$
 - Equipped with pressure-resistant sight glass to check liquid refrigerant charging.
 - A manifold with separate ports for HFCs and previous refrigerants is equipped as standard accessories.
- Differences
 - Measurement is based on weight to prevent change of mixing ratio during charging.

10. Charge mouthpiece



- Specifications
 - For R-410A, 1/4" \rightarrow 5/16" (2min \rightarrow 2.5min)
 - Material is changed from CR to H-NBR.
- Differences
 - Change of thread specification on hose connection side (For the R-410A use)
 - Change of sealer material for the HFCs use.

Index

Symbols

“88” cannot be Cleared from the Central Remote Controller202

A

Additional Charge of Refrigerant at installation time ... 45
Air Tight Test.....36
Applicable range of Field setting92

B

Brazing29

C

Centralized Control Group No. Setting.....97
Cracks develop in field pipes due to thermal expansion and contraction200
Cylinder specifications336

D

Detailed Explanation of Setting Modes93
Drain Pipe Gradient and Support47
Drain Pipe Work (Indoor)47
Drain Piping for Each Model49
 Ceiling Mounted Built-in Type (FXSQ-M)59
 Ceiling Mounted Cassette Corner Type (FXKQ-MA)55
 Ceiling Mounted Cassette Type (FXCQ-M Double flow)49
 Ceiling Mounted Cassette Type (FXFQ-M Multi-flow)52
 Ceiling Mounted Duct Type (FXMQ-MA)61
 Ceiling Suspended Cassette Type (FXUQ-MA) ... 67
 Ceiling Suspended Type (FXHQ-MA).....63
 Floor Standing/Concealed Floor Standing Type (FXLQ-MA, FXNQ-MA).....66
 Outdoor Air Processing Unit (FXMQ-MF)70
 Slim Ceiling Mounted Duct Type (FXDQ)57
Drain Trap47

E

Electrical Work71
Example 5
 Excessive Noise due to Incorrect Angling of REFNET Joints199
External Appearance.....3
 Indoor Units Heat Pump
 50Hz/60Hz, Cooling Only
 50Hz3

F

F6203
Field Setting88
Field Setting from Outdoor Unit.....101

Field Wiring Heat Pump, Cooling Only (50Hz/60Hz).. 192

Field Wiring Heat Pump, Cooling Only (50Hz/60Hz).. 192

Filter Sign Setting 93
Flange Connection 34
Flare Connection 30
Flaring Procedure 32

H

Hand Over to Customer 127

I

Installation 19
Installation of Indoor Unit 21
Installation of Outdoor Unit..... 78

M

Mismatch between cables connecting indoor and outdoor units and corresponding piping 196

O

Operating Noise of Indoor Units 128
Operation when Power is Turned On 86
Outdoor Unit Multi Connection Piping Kit 145
Outdoor Unit PC Board Layout 87

P

Pipe Size Selection 139
Piping Diameter for Grouped Drain Pipes 49
Piping Installation Point 130
 The Example of A Wrong Pattern 131
Piping System Diagrams 170
 Outdoor Unit 170
Precautions for New Refrigerant (R-410A)..... 334
Pressure down despite absence of leaks during air tight test..... 198

R

Reducer 162
REFNET Header 161, 163
REFNET Joint 160
REFNET Joints 163
Refrigerant Leaks 124
Refrigerant Pipe Work 22

S

Selection of Location 75
Service Space 76
Service Tools 337
Setting by dip switches 102
Setting by pushbutton switches 103
Setting Contents and Code No. – VRV Indoor unit 91
Setting mode 1 104
Setting mode 2 105
Setting of Low Noise Operation and Demand

Operation	116
Signal Interference due to Use of Multiple Core Cable 195	
Simplified Remote Controller	90
BRC2A51	90
BRC2C51	90
Sleeve and Insert Work	20
T	
Test Operation	82
Procedure and Outline	82
Thermal Insulation Work	35
Transmission Wiring between the Cool/heat Selector and the Outdoor Unit is too Close to a High Voltage Wire	201
V	
Vacuum Drying	39
VRV Inspection Sheet	165
W	
Wireless Remote Controller - Indoor Unit	89
Wiring Diagrams (Heat Pump 50Hz/60Hz, Cooling Only 50Hz)	182

Drawings & Flow Charts

A		D	
Additional Charge of Refrigerant at installation time ...		Degree of vacuum	41
45		Drain Pipe Trap Shape Defective	197
Operational steps	45	Drain Pipe Work (Indoor)	47
Refrigerant Charging Instructions	45	Drain Pipe Gradient and Support	47
Siphon tube	45	Drain Trap	47
Air	95	Grouped Drain Piping	48
Air Tight Test	36	Operational steps	47
Checking for Leaks	38	Use of an Auxiliary Drain Hose (Flexible)	48
Compensating adjustment value	37	Duct Work (Indoor)	74
Operational steps	36	Operational steps	74
		Taking Account of Noise and Vibration	74
B		E	
Branch with Refnet Header	135	Electrical Work	71
Branch with Refnet Joint	133	a PCB for remote control, multiple core cable	
Branch with Refnet Joint and Refnet Header	134	must not be used	71
Brazing	29	Choosing a circuit breaker	72
		Earthing	73
C		When cable less than 0.75 mm ² is used	71
Calculating Operating Noise	129	When cable more than 1.25 mm ² is used	71
Calibration method	42	Example 5	
Ceiling Mounted Built-in Type (FXSQ-M)	59	Excessive Noise due to Incorrect Angling of	
drain hose	59	REFNET Joints	199
Drain Piping	59	Example of connection	132
DRAIN RAISING PIPING	59		
drainage flow	60	F	
ELECTRIC WIRING WORK	60	Field Setting from Outdoor Unit	101
multiple drain pipes	59	Mode changing procedure	103
Ceiling Mounted Duct Type (FXMQ-MA)	61	Field Wiring Heat Pump, Cooling Only (50Hz/60Hz)	
Ceiling Suspended Cassette Type (FXUQ-MA)	67	RX(Y)Q18, 20, 22, 24, 26, 28, 30, 32MAY1 ..	193
Ceiling Suspended Type (FXHQ-M)		RX(Y)Q34, 36, 38, 40, 42, 44, 46, 48MAY1 ..	194
Drain hose	63	RX(Y)Q5P, 8P, 10P, 12P, 14P, 16P, 18PY1 ..	192
drainage	64	RXYQ5P, 8P, 10P, 12P, 14P, 16P, 18PYL ..	192,
Rig the drain pipe	63	193,	194
Ceiling Suspended Type (FXHQ-MA)	63	Flare Gauge	30
Centralized Control Group No. Setting	97	Flaring Procedure	32
BRC1A Type	97	Flaring tool	338
BRC4C Type	98	Floor Standing/Concealed Floor Standing Type	
BRC7C Type	98	(FXLQ-MA, FXNQ-MA)	66
BRC7E Type	98	G	
Group No. Setting Example	98	Gauge manifold for R-410A	340
Charge hose for R-410A	341	H	
Charge mouthpiece	342	Hand Over to Customer	127
Charging cylinder	341	Important Points	127
Choice of Materials for Refrigerant Piping	26	Make the service contact address clear	127
Contents of Control Modes	99	Operational Steps	127
How to Select Operation Mode	100	How to Calculate the Additional Refrigerant to be	
Contract Drawing	16	Charged	141
Cool / Heat Mode Switching	111	How to Select the Refnet Header	137
Covering of Refrigerant Pipes	24	How to Select the Refnet Joint	136
Particular care	24		
Pinching method	24		
Taping method	24		
Cracks Develop in Field Pipes due to Thermal			
Expansion and Contraction	200		

I	
Inspecting and Handling the Unit	77
Installation of Indoor Unit	21
Ceiling mounted cassette type (FXCQ63M)	21
Operational steps	21
Positioning	21
Installation of Outdoor Unit	78
Bolt Pitch	79
Operational steps	78
Unpacking and Placing the Unit	79
L	
Leak tester	340
M	
Mismatch between Cables Connecting Indoor and Outdoor Units and Corresponding Piping	196
O	
Outdoor Air Processing Unit (FXMQ-MF)	70
Outdoor Unit Multi Connection Piping Kit	145
BHFP22P100 • 151	145
Outdoor Unit PC Board Layout	87
P	
Pipe Size Selection	139
Piping Installation Point	130
Piping System Diagrams	170
Indoor Unit	178
RXQ10PY1, RXQ12PY1	172
RXQ14PY1, RXQ16PY1, RXQ18PY1	173
RXQ5PY1	170
RXQ8PY1	171
RXYQ10PY1, RXYQ12PY1	172
RXYQ10PYL, RXYQ12PYL	176
RXYQ14PY1, RXYQ16PY1, RXYQ18PY1	173
RXYQ14PYL, RXYQ16PYL, RXYQ18PYL	177
RXYQ5PY1	170
RXYQ5PYL	174
RXYQ8PY1	171
RXYQ8PYL	175
Positioning of indoor unit	13
Positioning of outdoor unit	12
Pressure down Despite Absence of Leaks during Air Tight Test	198
R	
Reducer	162
REFNET Header	161, 163
REFNET Joint	160
REFNET Joints	163
Refrigerant Cylinders	336
Refrigerant oil (Air compal)	340
Refrigerant Pipe Flushing	25
Fit blanking plugs	25
Flushing	25
Open the main valve on the nitrogen cylinder and set the pressure regulator to 0.5MPa	25
Set pressure regulator on nitrogen cylinder	25
Refrigerant Pipe Work	22
Air tight	22
Clean	22
Dry	22
Operational steps	22
The 3 principles of refrigerant piping	22
Refrigerant R-410A	334
RXQ12PY1	190
RXQ14PY1	191
S	
Selection of Location	75
Service Space	76
Service Tools	337
Set the flaring tool	30
Setting of Air Flow Direction Adjustment Range	95
Setting of Demand Operation	118
Setting of Low Noise Operation and Demand Operation	116
Image of operation in the case of A	117, 119
Image of operation in the case of A and B	117, 119
Image of operation in the case of B	117, 119
Signal interference due to use of multiple core cable. 195	195
Simplified Remote Controller	90
BRC2A51	90
BRC2C51	90
Size of Main Gas and Liquid Pipes and Allowable Length	142
Sleeve and Insert Work	20
Operational steps	20
Steel insert	20
Through holes in a reinforced concrete beam	20
Special vacuum drying	44
Step by Step Installation Procedure	19
Striking a Balance between System Installation and General Construction Work	15
Supplementation on É and Ñ	115
T	
The analysis of major installation problems	14
Thermal Insulation Work (Refrigerant Piping)	35
Essential Points of Thermal Insulation	35
Operational steps	35
Tighten the bolts in opposite corners first to ensure that the connection is true	34
Torque wrench	339
Transmission wiring between the cool/heat selector and the outdoor unit is too close to a high voltage wire	201
Turn Power On	83
V	
Vacuum Drying	39
Vacuum Drying Procedure	43
Vacuum pump with check valve	339
VRV Inspection Sheet	165
W	
Wall Mounted Type (FXAQ-M, FXAQ-MH) connecting a hard vinyl chloride pipe joint	65
drain hose	65

Wall Mounted Type (FXAQ-MA)
 drain piping65
Weigher for refrigerant charge342
Wiring Diagrams (Heat Pump 50Hz/60Hz, Cooling
 Only 50Hz) 182
 RXQ10PY1 189
 RXQ12PY1 190
 RXQ14PY1, RXQ16PY1, RXQ18PY1 191
 RXQ5PY1 187
 RXQ8PY1 188
 RXYQ10PY1, RXYQ10PYL..... 184
 RXYQ12PY1, RXYQ12PYL..... 185
 RXYQ14PY1, RXYQ16PY1, RXYQ18PY1,
 RXYQ14PYL, RXYQ16PYL,
 RXYQ18PYL..... 186
 RXYQ5PY1, RXYQ5PYL..... 182
 RXYQ8PY1, RXYQ8PYL..... 183

In all of us,
a green heart



Daikin's unique position as a manufacturer of air conditioning equipment, compressors and refrigerants has led to its close involvement in environmental issues. For several years Daikin has had the intension to become a leader in the provision of products that have limited impact on the environment. This challenge demands the eco design and development of a wide range of products and an energy management system, resulting in energy conservation and a reduction of waste.



Daikin Europe N.V. is approved by LRQA for its Quality Management System in accordance with the ISO9001 standard. ISO9001 pertains to quality assurance regarding design, development, manufacturing as well as to services related to the product.



ISO14001 assures an effective environmental management system in order to help protect human health and the environment from the potential impact of our activities, products and services and to assist in maintaining and improving the quality of the environment.



Daikin units comply with the European regulations that guarantee the safety of the product.

The present publication is drawn up by way of information only and does not constitute an offer binding upon Daikin Europe N.V.. Daikin Europe N.V. has compiled the content of this publication to the best of its knowledge. No express or implied warranty is given for the completeness, accuracy, reliability or fitness for particular purpose of its content and the products and services presented therein. Specifications are subject to change without prior notice. Daikin Europe N.V. explicitly rejects any liability for any direct or indirect damage, in the broadest sense, arising from or related to the use and/or interpretation of this publication. All content is copyrighted by Daikin Europe N.V..

DAIKIN EUROPE N.V.
Naamloze Vennootschap
Zandvoordestraat 300
B-8400 Oostende - Belgium
www.daikin.eu
BTW: BE 0412 120 336
RPR Oostende

VRV products are not within the scope of the Eurovent certification programme.

